

# iBoard®



Scan for  
Installation Video

## iBoard® by APS

PART#: IB-R197/R198

READ INSTRUCTIONS CAREFULLY BEFORE STARTING INSTALLATION. REMOVE CONTENTS FROM BOX AND VERIFY ALL PARTS ARE PRESENT. ASSISTANCE IS RECOMMENDED.

\*ROCKER PANEL MOUNT  
\*NO DRILLING REQUIRED

Fastener Size	Tightening Torque (ft-lbs)	Required
6mm	6-7	√
8mm	16-18	√
10mm	31-32	X
12mm	56-58	X
14mm	92-94	X

Driver

Front  
↑

Passenger

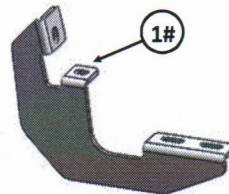
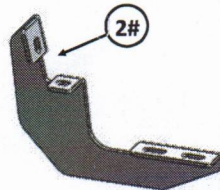
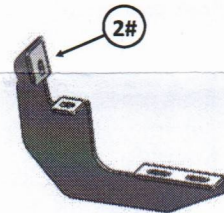
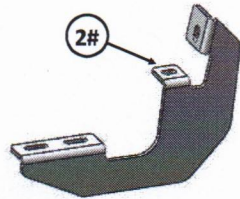
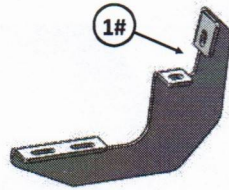
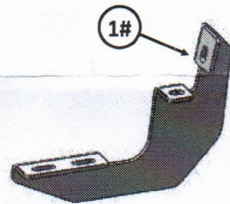

Customer Support: [info@iboardauto.com](mailto:info@iboardauto.com)

# iBoard®



Scan for  
Installation Video

## Hardware Package A (For Bracket Installation)

Item	QTY	Description	Item	QTY	Description
1#	3	Driver Front/Center & Passenger Rear Mounting Brackets	4#	12	M8 Large Flat Washers
2#	3	Passenger Front/Center & Driver Rear Mounting Brackets	5#	12	M8 Lock Washers
3#	12	M8X1.25-30mm Hex Bolts	6#	12	M8 Clip Nuts



3 #



4#



5#



6 #

## Hardware Package B (For Step Bar Installation)

Item	QTY	Description	Item	QTY	Description
1#	12	M6X1-20mm Square Head Bolts	3#	12	M6 Nylon Lock Nuts
2#	12	M6 Large Flat Washers			



1#



2#



3#

Customer Support: [info@iboardauto.com](mailto:info@iboardauto.com)

# iBoard®



Scan for  
Installation Video

## STEP 1

Start installation from the driver side front of the vehicle. If equipped, remove the plastic covers from the mounting locations on rocker panel, (Fig 1).

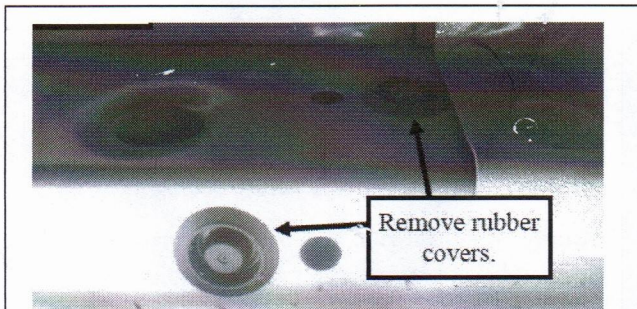

(Fig 1) Driver Side Front Mounting Location

## STEP 2

Install the M8 Clip Nuts in the holes where the plastic covers were removed, (Fig 2).

Select the Driver Front Mounting Bracket, attach the Bracket to the vehicle by using the included (2) M8x1.25-30mm Hex Bolts, (2) M8 Lock Washers and (2) M8 Large Flat Washers, (Fig 3). Do not fully tighten hardware at this time.

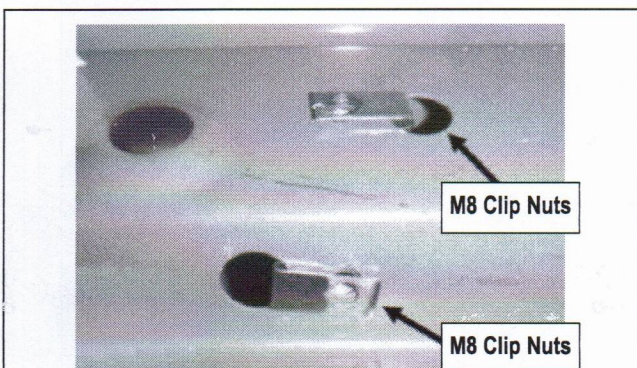

(Fig 2) Supplied M8 Clip Nuts Installed

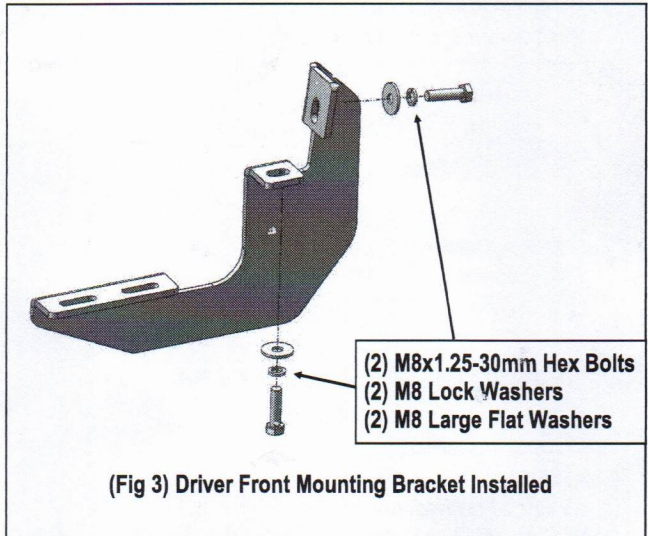

(Fig 3) Driver Front Mounting Bracket Installed

## STEP 3

Move to the driver side center and rear mounting locations, (Fig 1). Repeat **Steps 1 & 2** to install the Driver Center & Rear Mounting Brackets.

## STEP 4

Once all (3) mounting brackets are installed. Select a Running Board. Slip (3) M6X1-20mm Square Head Bolts into each bottom channel (Fig 4). Carefully position the Running Board onto the (3) Mounting Brackets. Attach the Running Board to each Mounting Bracket with (2) M6X1-20mm Square Head Bolts, (2) M6 Large Flat Washers and (2) M6 X1 Nylon Lock Nuts (Fig 5). Do not fully tighten at this time.

**IMPORTANT:** Do not slide the Running Board on the Brackets or the bottom surface of the board will be damaged.

Customer Support: [info@iboardauto.com](mailto:info@iboardauto.com)

# iBoard®



Scan for  
Installation Video

M6X1-20mm Square Head Bolts

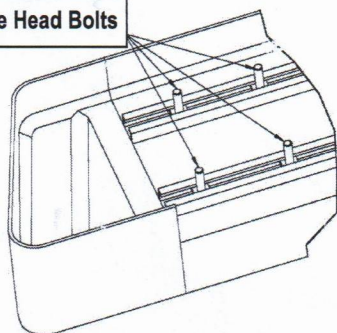

(Fig 4) Slip M6X1-20mm Square Head Bolts Into The Bottom Channels

(2) M6X1-20mm Square Head Bolts  
(2) M6 Large Flat Washers  
(2) M6X1 Nylon Lock Nuts

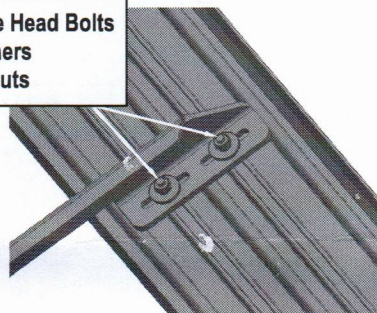

(Fig 5) Running Board Installed Onto Mounting Bracket

## STEP 5

Level and adjust the Running Board and fully tighten all hardware.

**Important:** Please follow the recommended Tightening Torques shown in the table on page 1. Don't over tighten, or the nuts/bolts will be damaged.

## STEP 6

Repeat **Steps 1-5** for the other side Running Board installation. The installation is completed .

### Attention

Do periodic inspections to the installation to make sure that all hardware is secure and tight.

In order to protect your bars/boards, please use mild soap/non-abrasive products for cleaning only.