



TEL: 1-866-XANATOS

INSTALLATION INSTRUCTIONS

**3" BEACON BULL BAR
15-22 CHEVY COLORADO (Excl. ZR2)/GMC CANYON
PART#BE-GMCOB/BE-GMCOS**

PARTS LIST:

Qty	Description	Qty	Description
1	3in Bull Bar	4	10-1.5mm x 30mm Hex Bolts
1	Driver/left Mounting Bracket	8	10mm x 24mm OD x 2.2mm Flat Washers
1	Passenger/right Mounting Bracket	4	10-1.5mm Nylon Lock Nuts
4	12-1.75mm x 80mm Hex Bolts	1	20inch LED Single Row Light
8	12mm x 24mm OD x 2.5mm Flat Washers		
4	12-1.75mm Nylon Lock Nuts		

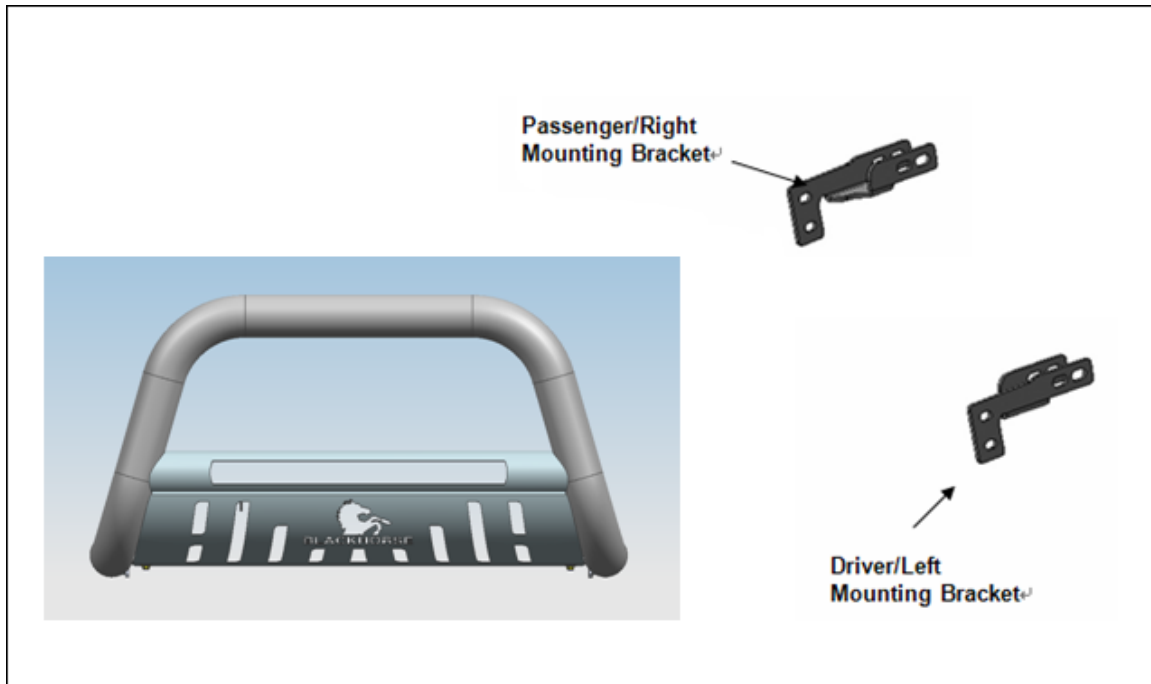

PROCEDURE:

REMOVE CONTENTS FROM BOX AND VERIFY ALL PARTS ARE PRESENT. READ INSTRUCTIONS CAREFULLY. CUTTING MAY BE REQUIRED. INSTALLATION MAY INTERFERE WITH FRONT MOUNTED SENSORS. NOTE: It may be necessary to remove/relocate front license plate and license plate bracket. It is not required, but strongly recommended. If local/state law requires a front license plate, license plate relocation kit is available.

1. Start installation from under the front of the vehicle. Remove the plastic splash guard from below-behind bumper, **(Figure 1)**. Determine if the vehicle is equipped with tow hooks. **IMPORTANT:** Tow hooks cannot be reinstalled with the Bull Bar. Also, it may be necessary to temporarily remove the factory skid plate, (if equipped), to access the mounting locations.

Tow Hook equipped vehicles:

- a. Remove the driver side tow hook and hardware from the end of the frame channel, **(Figures 2 & 3)**. Also remove the seal between the opening in the bumper and the tow hook, **(Figure 4)**.
- b. Repeat to remove the passenger side tow hook.
- c. Proceed to **Step 2**.

Vehicles without tow hooks:

- a. Cut out the indented area in both sides of the plastic bumper to clear the Brackets as pictured, **(Figures 4 & 5)**. **IMPORTANT:** Make several small cuts for best fit. **OPTION:** Cut around the Bracket as indicated, **(Figure 5)**, or cut along the rectangular cut line molded into the pocket.
2. Select the driver side Mounting Bracket. Insert the Bracket through the opening in the bumper and up to the tow hook mounting holes, **(Figures 7 & 8)**. Trim the plastic as required Bracket clearance.
 3. Line up the (2) holes in the Bracket with the (2) holes in the frame for the tow hook. Select (2) 12mm x 80mm Long Hex Bolts and (2) 12mm Flat Washers, **(Figure 8)**. Insert the Bolts with Washers through the

Bracket and the (2) holes through the frame, **(Figure 7)**. Secure with (2) 12mm Flat Washers and (2) 12mm Nylon Lock Nuts. Do not fully tighten hardware at this time.

4. Repeat **Steps 2 & 3** to install the passenger side Mounting Bracket.

5. **LED Light Installation**

a. Use (2) 6mm Socket Head Cap Screw, (2) 6mm Lock Washers and (2) 6mm Flat Washers to attach the Light Bar Brackets to the Bull Bar, **(Figure 8)**.

b. Follow the light manufacturer's instructions to attach the Bull Bar.

c. Follow light manufacturer's instructions to properly wire the Bull Bar

6. With assistance, hold the Bull Bar up in position on the outside of the Mounting Brackets. Bolt the Bull Bar to the Brackets with (4) 10mm x 30mm Hex Bolts, (8) 10mm Flat Washers and (4) 10mm Nylon Lock Nuts, **(Figure 10)**. Do not tighten hardware at this time.

7. Check the Bull Bar alignment with the vehicle and for clearance between the Bull Bar and the bumper. Adjust as required then fully tighten all hardware at this time.

8. Reinstall the plastic splash guard or skid plate removed in **Step 1, (Figure 1)**.

9. Do periodic inspections to the installation to make sure that all hardware is secure and tight.

To protect your investment, wax this product after installing. Regular waxing is recommended to add a protective layer over the finish. Do not use any type of polish or wax that may contain abrasives that could damage the finish.

For stainless steel: Aluminum polish may be used to polish small scratches and scuffs on the finish. Mild soap may be used also to clean the Bull Bar.

For gloss black finishes: Mild soap may be used to clean the Bull Bar.

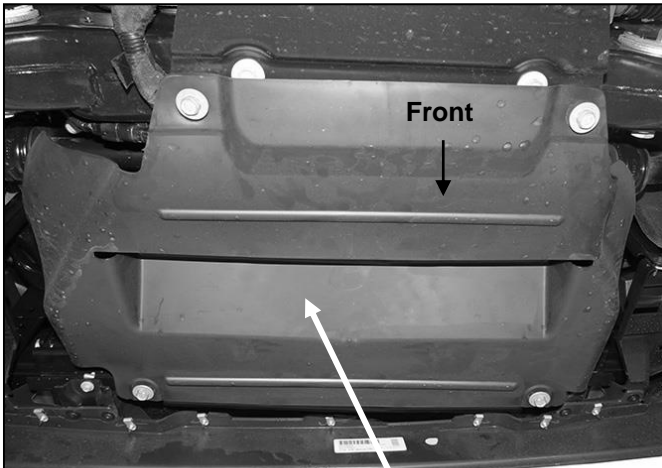

(Fig 1) Remove splash guard or skid plate from bottom of engine behind bumper if necessary

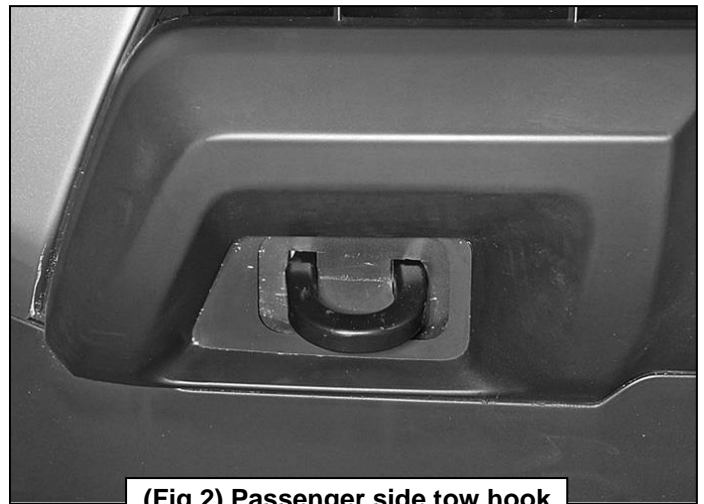

(Fig 2) Passenger side tow hook

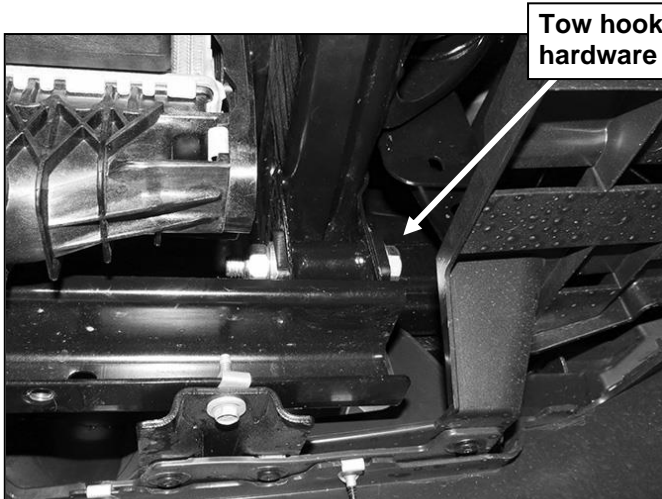

(Fig 3) Passenger side pictured from behind bumper



(Fig 4) Driver side mounting location

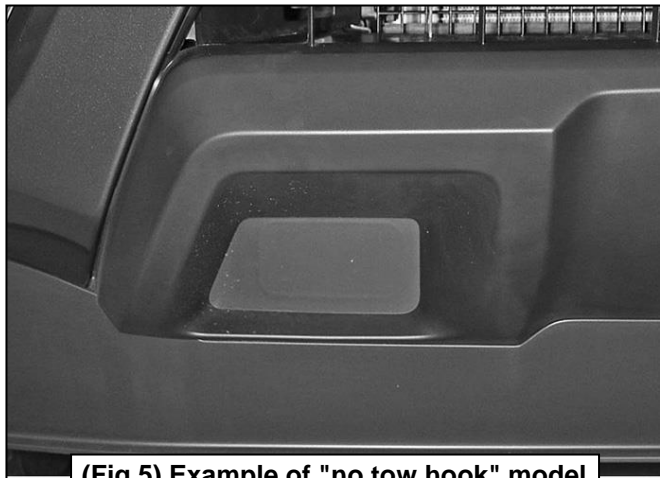

(Fig 5) Example of "no tow hook" model

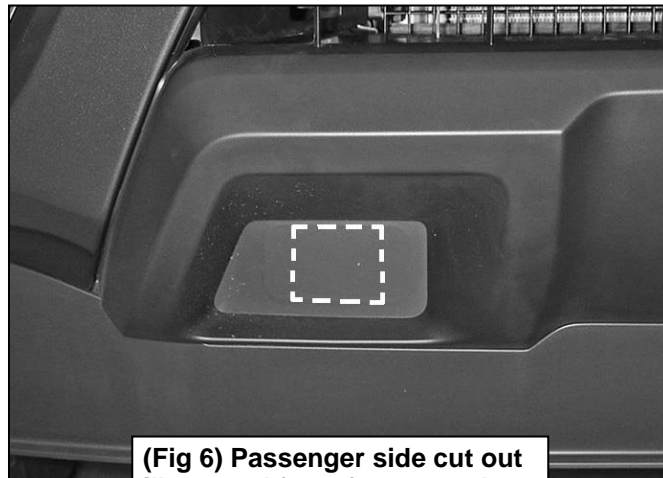

(Fig 6) Passenger side cut out illustrated for reference only

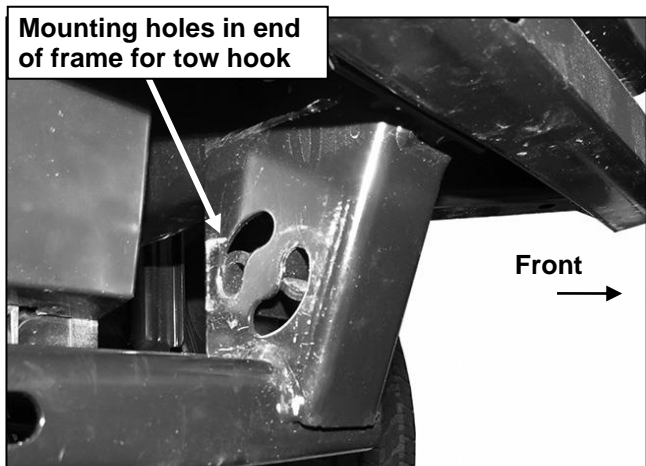

(Fig 7) Driver side pictured without bumper for instruction purposes only. Do not remove bumper

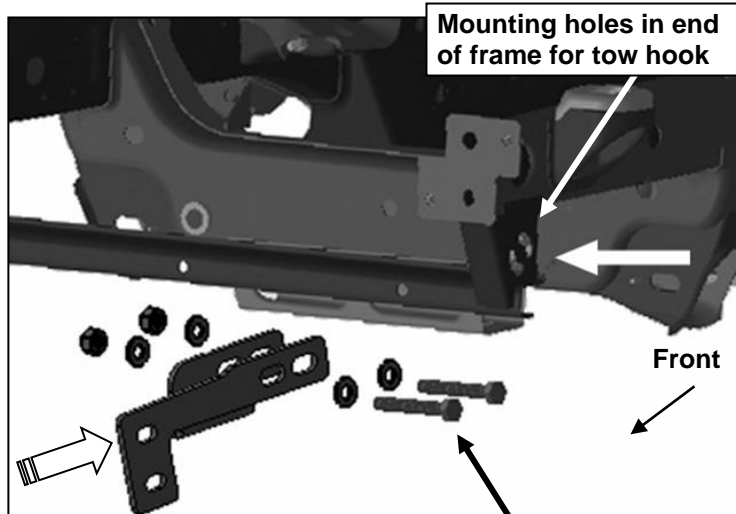
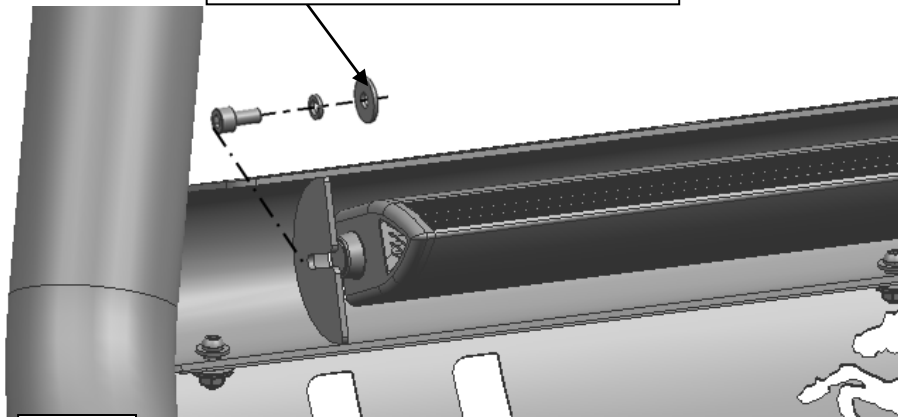

Fig 8

- (2) 12mm x 80mm Hex Bolts
- (4) 12mm Flat Washers
- (2) 12mm Nylon Lock Nuts

- (1) 6mm Socket Head Cap Screw
- (1) 6mm Lock Washer
- (1) 6mm x 18mm OD x 1.6mm Flat Washers



(Fig 9)

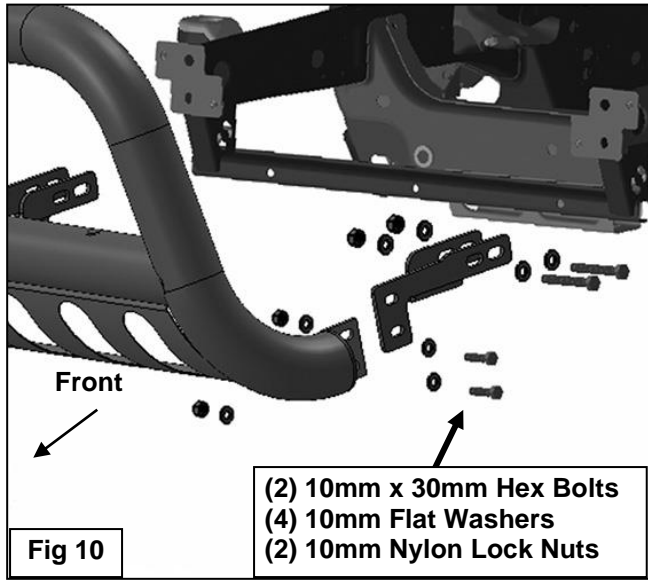

Complete Installation

