

**LD1 FRONT BUMPER
2019-20 FORD RANGER**

PARTS LIST:

1	LD1 Front Bumper	2	8-1.25mm x 25mm Hex Bolts
1	Driver/Left L-Bracket	2	8-1.25mm x 16mm Hex Bolts
1	Passenger/Right L-Bracket	6	8mm x 24mm x 2mm Flat Washers
1	License Plate Bracket	4	8mm Lock Washers
2	License Plate Plugs	2	8mm Hex Nuts
1	Sensor Cover Kit	2	6-1.0mm x 20mm Button Head Bolts
4	20mm x 10mm Sensor Foam Washers	4	6mm x 18mm x 1.6mm Flat Washers
4	15.5mm x 25mm x 2mm Sensor Foam Washers	2	6mm Nylon Lock Nuts
4	Sensor Retaining Clips	10	Nylon Ties
4	Rubber Sensor Plugs	1	4mm Wrench

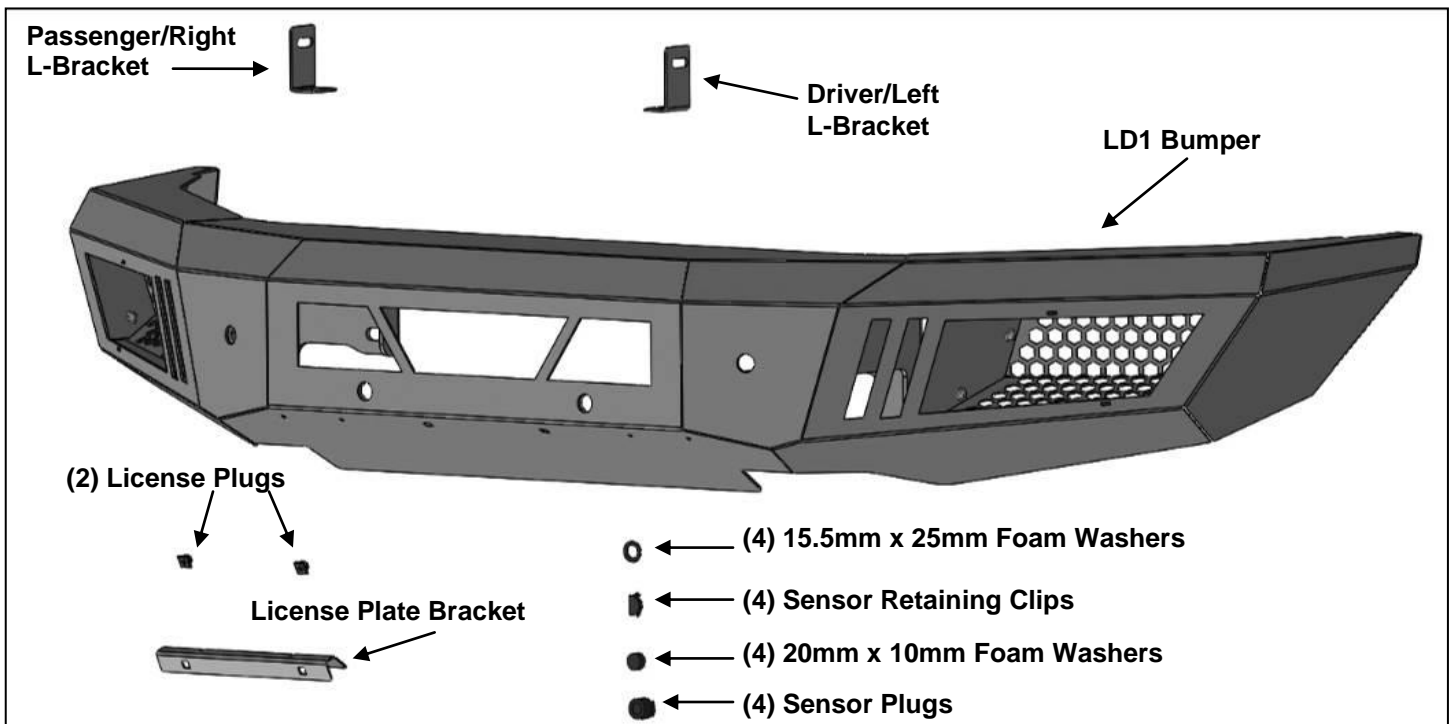

PROCEDURE: REMOVE CONTENTS FROM BOX. VERIFY ALL PARTS ARE PRESENT. READ INSTRUCTIONS CAREFULLY BEFORE STARTING INSTALLATION. BUMPER IS HEAVY, ASSISTANCE IS REQUIRED TO AVOID POSSIBLE INJURY OR DAMAGE TO THE VEHICLE.

1. **Models equipped with adaptive cruise control** will not be able to reattach the ACC.
2. Move to the front of the vehicle. Remove the license plate. If the vehicle is equipped with tow hooks, remove the plastic covers and the tow hooks, **(Figures 1 & 2)**.
3. Unplug the center wire harness located in the hole in the bumper under the license plate on the right side, if equipped, **(Figure 3)**. Remove the center plastic cover from the front of the bumper, **(Figures 4 & 5)**. Release the wiring harness from the clips attached to the back of the plastic cover. Remove the center wiring harness from the plastic cover.
4. Place blocks or jack stands under the front bumper to support it during hex nut removal. Once the bumper has been safely supported remove the large factory hex nuts from the front of the bumper bracket attaching the bumper to the frame, **(Figure 6)**. **WARNING!** Assistance is required to hold the bumper in place during hardware removal to prevent the bumper from falling. With assistance, hold the bumper in position, unplug the outer wiring harness located underneath the Driver/Left headlight, **(Figure 7)**.
5. Remove bumper and place on a stable clean surface. Remove the wiring harness from the clips attached to the back of the bumper.
6. **For vehicles equipped with front sensors.**

**LD1 FRONT BUMPER
2019-20 FORD RANGER**

- a. Remove the silicone seal from the end of the sensor. Slide the 15.5mm x 25mm x 2mm Foam Washer over front of sensor, **(Figure 8)**.
- b. Insert sensor with Foam Washer into sensor sleeve.
- c. Place 20mm x 10mm Foam Spacer Washer over end of sensor. Push Sensor Retaining Clip into sensor mount and lock into mounting holes, **(Figures 8 & 9)**.
- d. Repeat previous Steps to install remaining sensors.

For vehicles not equipped with front sensors.

- a. Select the included (4) Rubber Plugs.
- b. From behind bumper, push plugs into sensor sleeves, **(Figure 10)**.

7. Inner Light Bar installation, (light not included).

- a. Select the Driver/Left L-Bracket. **NOTE:** L-Brackets are offset to adjust for different widths of Light Bars.
- b. Attach the L-Bracket to the slot on the back of the Bumper with (1) 8mm x 25mm Hex Bolt, (2) 8mm Flat Washers, (1) 8mm Lock Washer and (1) 8mm Hex Nut, **(Figure 11)**. Repeat this Step to install the Passenger/Right L-Bracket on the other side of the Bumper.
- c. Attach the Light Bar, (Not Included), to the L-Brackets with (2) 8mm x 16mm Hex Bolts, (2) 8mm Lock Washers and (2) 8mm Flat Washers, **(Figure 12)**. Do not fully tighten hardware at this time.

Outer Light installation, (light not included).

- a. Attach lights to the mounting location at the outer-ends of the Bumper, **(Figure 13)**.
 - b. Follow the light manufacturer's instruction to properly wire lights once Bumper is installed.
- 8.** Locate the front frame mounting locations, **(Figure 14)**. With assistance, slide the bumper over the factory bolt plates, **(Figure 15)**. Temporarily support the weight of the Bumper. **WARNING:** To avoid possible injury or damage to the vehicle, do not proceed until the bumper is fully and safely supported.
- 9.** Reuse the (6) factory hex nuts to secure the Bumper to the bolt plates. Do not fully tighten hardware.
- 10.** Level and adjust the bumper and fully tighten all hardware.
- 11.** Attach the License Plate Bracket to the holes in the bumper with the included (2) 6mm x 20mm Button Head Bolts, (4) 6mm Flat Washers and (2) 6mm Nylon Lock Nuts. Insert (2) Plastic Plugs into the square holes in the Bracket. Reuse the factory screws to attach the license plate to the plastic plugs, **(Figures 16 & 17)**.
- 12.** Do periodic inspections to the installation to make sure that all hardware is secure and tight.

To protect your investment, Do not use any type of polish or wax that may contain abrasives that could damage the finish. Mild soap may be used to clean the Bumper assembly.

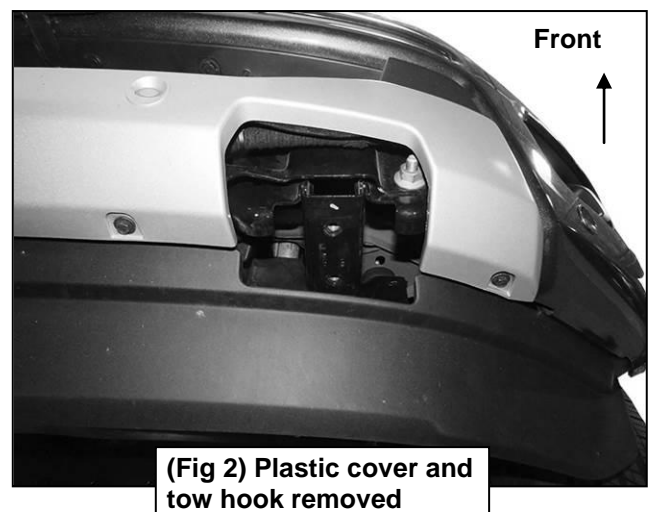



(Fig 5) Center plastic cover removed

WARNING! Do not remove bumper bolts unless the bumper is properly supported on blocks or stands or the bumper may fall.



(Fig 4) Remove the center plastic cover

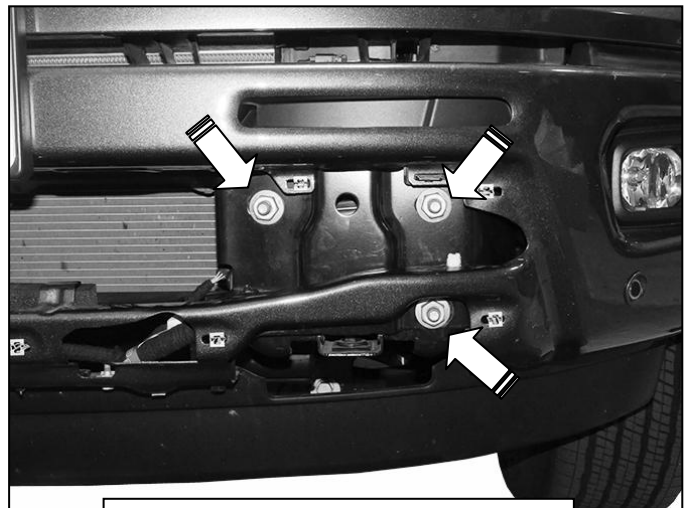

(Fig 6) Remove the nuts attaching the bumper to the frame

Driver Side Installation Pictured



(Fig 7) Pull the bumper out slightly and unplug the outer wire harness

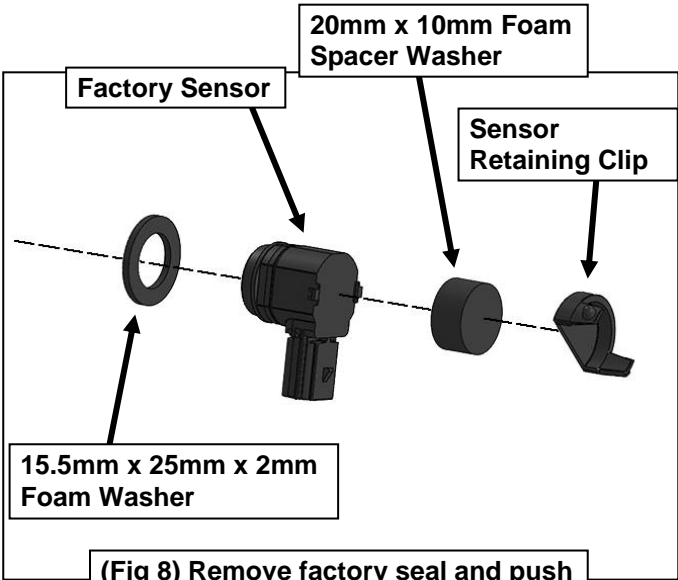

(Fig 8) Remove factory seal and push Foam Washer onto end of sensor

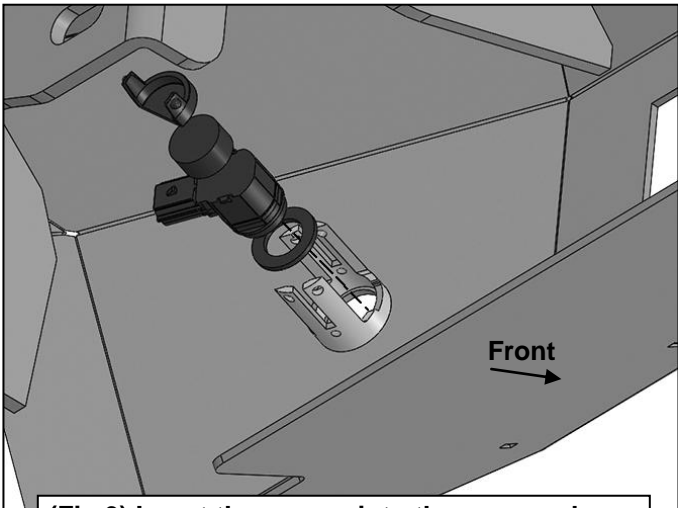

(Fig 9) Insert the sensor into the sensor sleeve

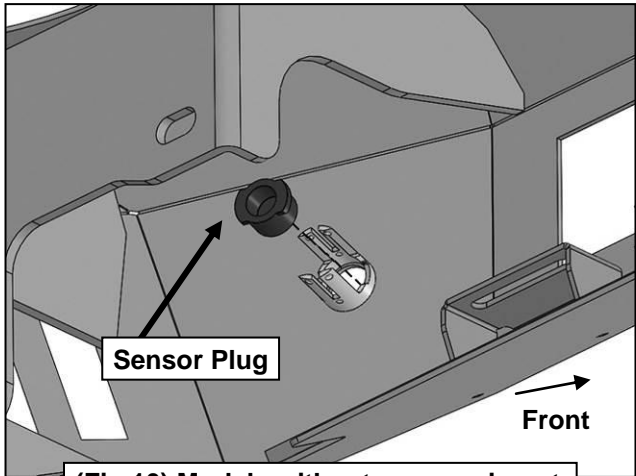

(Fig 10) Models without sensors insert sensor plugs into the sensor sleeve

Driver Side Installation Pictured

**LD1 FRONT BUMPER
2019-20 FORD RANGER**

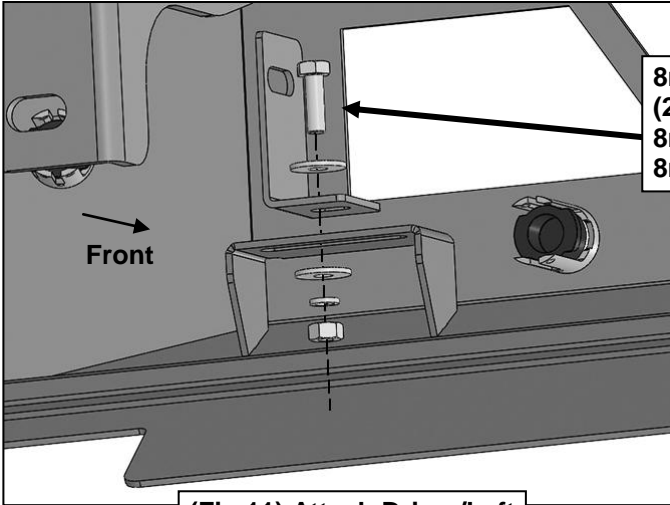

**8mm x 25mm Hex Bolt
(2) 8mm Flat Washers
8mm Lock Washer
8mm Hex Nut**

**(Fig 11) Attach Driver/Left
L-Bracket to the Bumper**

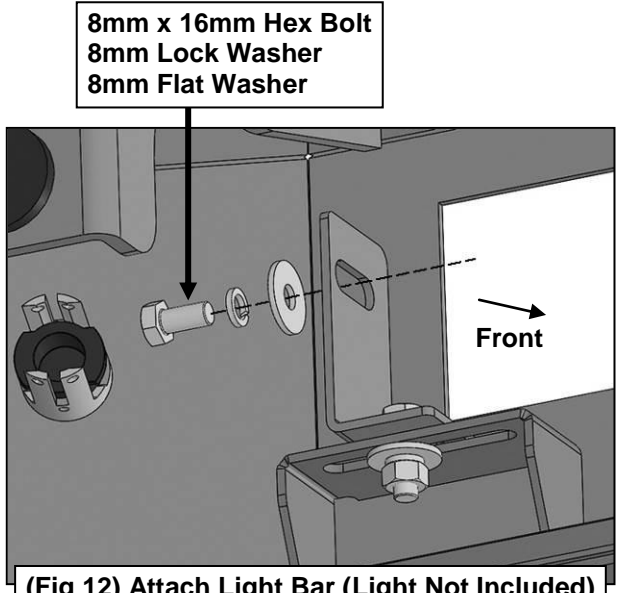

**8mm x 16mm Hex Bolt
8mm Lock Washer
8mm Flat Washer**

(Fig 12) Attach Light Bar (Light Not Included)

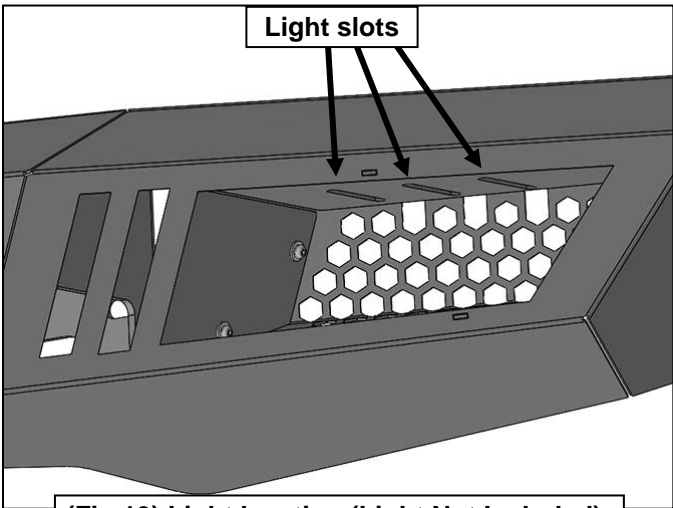

Light slots

(Fig 13) Light location (Light Not Included)



(Fig 14) Driver/Left mounting location

Driver Side Installation Pictured

**LD1 FRONT BUMPER
2019-20 FORD RANGER**

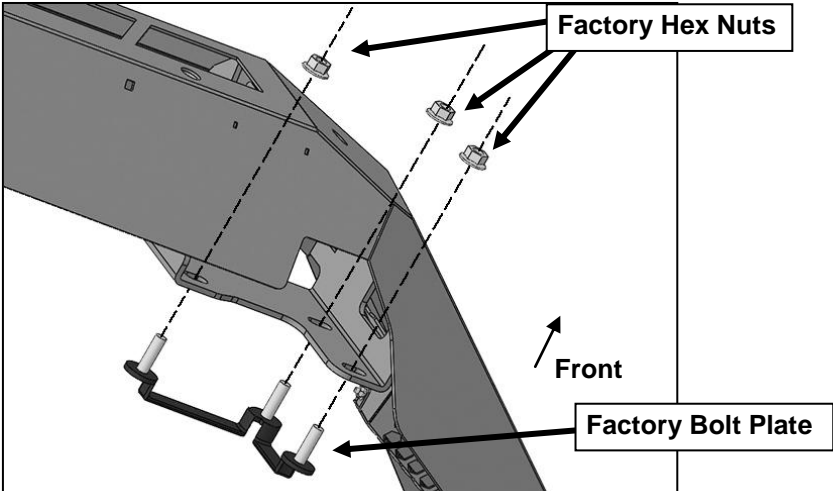

(Fig 15) Attach bumper to the mounting locations

- (2) 6mm x 20mm Button Head Bolts
- (4) 6mm Flat Washers
- (2) 6mm Nylon Lock Nuts

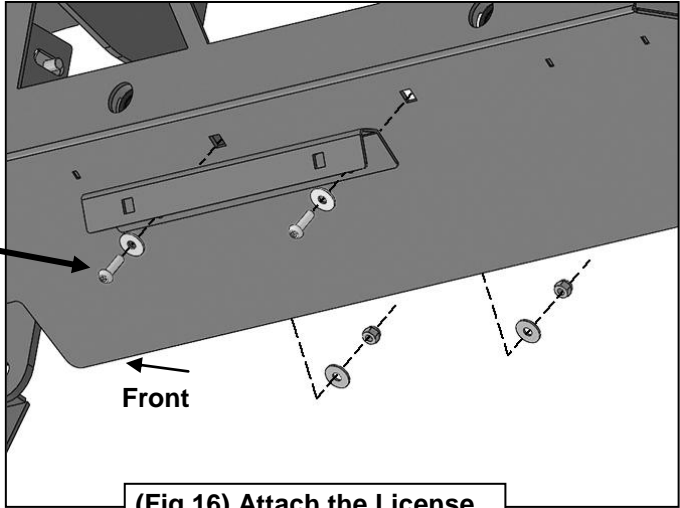

(Fig 16) Attach the License Plate Bracket to the Bumper

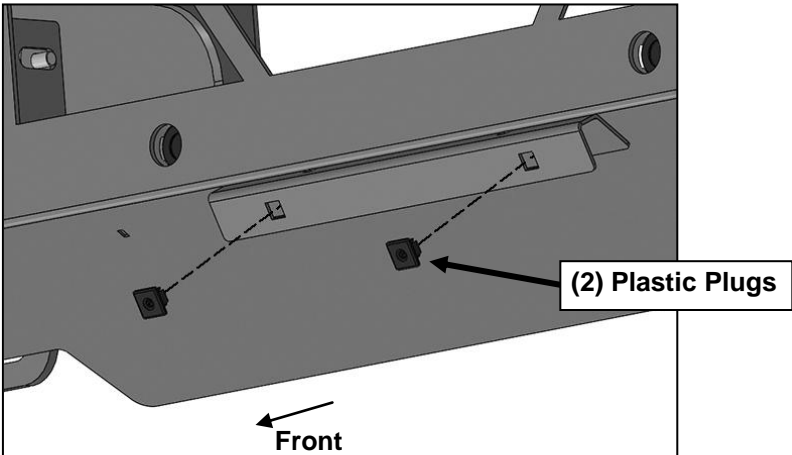

(Fig 17) Attach License Plate Bracket to Bumper