



INSTALLATION INSTRUCTIONS

**HD Off-Road Rear Bumper
2019-21 FORD RANGER**

PARTS LIST: FR4240

1	LD2 Rear Bumper Assembly	2	10mm x 35mm Single Bolt Plates
1	Driver/left Mounting Bracket	2	10mm Plastic Retainers
1	Passenger/right Mounting Bracket	2	10-1.5mm x 35mm Hex Bolts
1	Trailer Plug Relocation Bracket	8	10mm x 30mm x 2.5mm Flat Washers
2	Mesh Fill Panels	8	10mm Lock Washers
4	Sensor Hole Plugs	6	10mm Hex Nuts
4	Sensor Retaining Caps	4	6-1.00mm x 20mm Combo Bolts
4	20mm x 10mm Foam Spacers	4	6mm Flange Nuts
4	25mm x 15.5mm x 2mm Foam Seals	2	6mm x 20mm Button Head Bolts
1	Sensor Cover Kit	4	6mm x 18mm x 1.6mm Flat Washers
2	Plastic Plugs for license plate mount	2	6mm Nylon Lock Nuts
10	Nylon Wire Ties	8	4mm Self Tapping Screws
2	10mm Bolt/Nut Plates	1	4mm Wrench

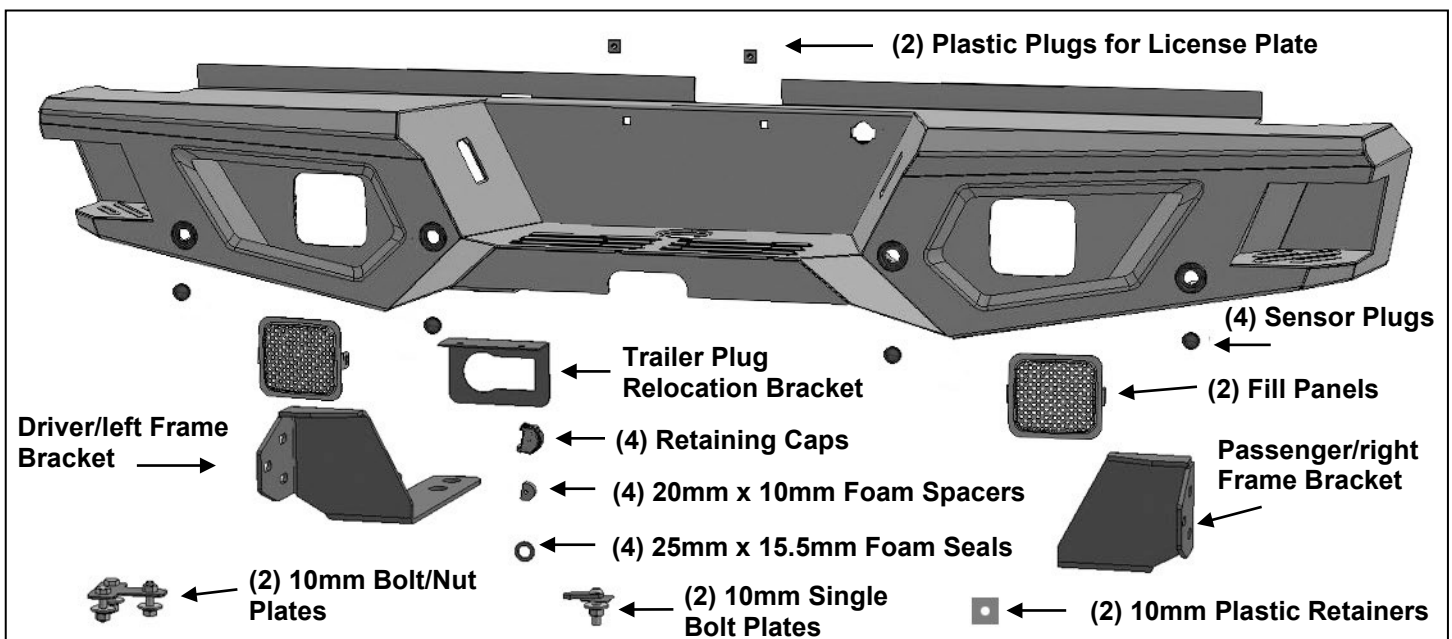

PROCEDURE:

REMOVE CONTENTS FROM BOX. VERIFY ALL PARTS ARE PRESENT. READ INSTRUCTIONS CAREFULLY BEFORE STARTING INSTALLATION. ASSISTANCE IS RECOMMENDED TO AVOID POSSIBLE INJURY OR DAMAGE TO THE VEHICLE.

1. Remove the license plate from the bumper. Unplug any wiring harnesses leading to the bumper, **(Figure 1)**. Move wiring harnesses away from bumper.
2. Place blocks or jack stands under the bumper to support it during mounting bolt removal. Once the bumper has been safely supported, remove the factory hex bolts attaching the bumper to the bottom of the frame and remove the bumper assembly, **(Figures 1 & 2)**. **WARNING!** Assistance is required to hold the bumper in place during hardware removal to prevent bumper from falling.
3. Disassemble the bumper and remove the bumper bracket reinforcement, (or receiver hitch, if equipped with tow package). Remove the wiring harness, license plate lights, trailer plug and spare tire access lock from the factory bumper. Remove sensors, (if equipped), from bumper, **(Figures 3 & 4)**.
4. Select (1) 10mm Single Bolt Plate. Insert the Bolt Plate into the end of the frame and through the hole in the outer side of the frame, **(Figures 5 & 6)**. Thread (1) 10mm Plastic Retainer onto the Bolt Plate to help hold it in place. Select the driver/left Frame Mounting Bracket, **(Figure 7)**. Attach the Bracket to the Bolt Plate with (1) 10mm Flat Washer, (1) 10mm Lock Washer and (1) 10mm Hex Nut. Leave hardware loose at this time. Repeat this Step to attach the passenger/right Frame Mounting Bracket to the end of the frame.

**LD2 REAR BUMPER
2019-21 FORD RANGER**

5. With assistance, hold the bumper reinforcement, (or receiver hitch), up to the bottom of the frame. Reuse the factory hex bolts to attach the bumper reinforcement, (or receiver hitch), to both Brackets and frame, **(Figure 8)**. Do not fully tighten hardware at this time.
6. Determine if the vehicle is equipped with sensors. **NOTE:** Depending on tow package, it may be necessary or easier to install sensors, (if equipped), before installing the Bumper.

Models without bumper sensors:

- a. From the front of the bumper, push the included Plastic Plugs into sensor mounting holes, **(Figure 9)**.

Models with bumper mounted sensors:

- a. Remove sensors from factory bumper, **(Figure 3)**.
 - b. Remove the silicone seal from the end of the sensor. Slide the included larger Sensor Seal over front of sensor, **(Figure 10)**.
 - c. Insert sensor with Seal into sensor mount on back of Bumper, **(Figure 11)**.
 - d. Place Foam Spacer over end of sensor. Push Sensor Retaining Cap onto sensor mount and lock into mounting holes, **(Figure 11)**.
 - e. Repeat previous Steps to install remaining sensors.
7. Determine if accessory lights, (not included), or Mesh Fill Panels will be installed at this time.

Mesh Fill Panel Installation (do not install fill panels if installing lights).

- a. Select the Fill Panels.
- b. Attach Panels with the included 6mm Combo Bolts and 6mm Flange Nuts, **(Figure 12)**. Fully tighten Fill Panel hardware at this time.

LED cube style light installation (light not included).

- a. Attach lights to mounting tabs on back of each end of the Bumper, **(Figure 12)**.
8. Install the license plate lights and spare tire access lock, **(Figure 13)**.
 9. Install factory harness into Bumper. Plug the bumper harness into the lights and sensors, (if equipped).
 10. With assistance, hold the Bumper up against the Brackets. Temporarily support the weight of the Bumper. **WARNING:** To avoid possible injury or damage to the vehicle, do not proceed until the bumper is fully and safely supported.
 11. Select (1) 10mm Bolt/Nut Plate, **(Figure 14)**. Insert the Bolt/Nut Plate into and through the outside of the tab on the back of the Bumper and through the Bracket. Attach the Bumper to the Bolt/Nut Plate with (1) 10mm x 35mm Hex Bolt, (3) 10mm Flat Washers, (3) 10mm Lock Washers and (2) 10mm Hex Nuts. Leave hardware loose at this time. Repeat this Step to attach the passenger/right side of the Bumper to the Bracket.
 12. Push the included (2) Plastic Plugs into the square holes in the Bumper for the license plate, **(Figure 15)**. On models with tow package, attach Plug Relocation Bracket to bottom of the Bumper with the included (2) 6mm Button Head Bolts, (4) 6mm Flat Washers and (2) 6mm Nylon Lock Nuts. Push trailer plug into Bracket and plug into harness.
 13. Slowly open the tailgate and check for clearance. Level and adjust the bumper and fully tighten all hardware including all Bracket to frame hardware.
 14. Plug the bumper wiring harness into the main harness. Use the included Wire Ties to secure the wiring harness to the bumper and frame as necessary.
 15. Do periodic inspections to the installation to make sure that all hardware is secure and tight.

To protect your investment, Do not use any type of polish or wax that may contain abrasives that could damage the finish. Mild soap may be used to clean the Bumper assembly.

Driver/left Side Installation Pictured

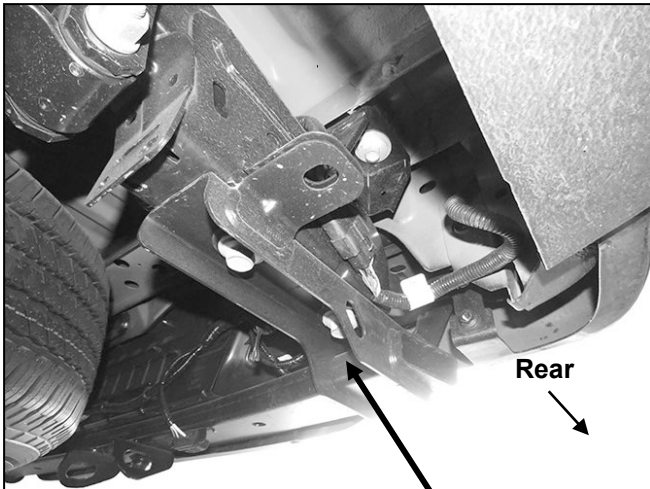

(Fig 1) Unplug all harnesses. Remove hex bolts from bottom of bumper reinforcement (pictured) or receiver hitch to remove bumper assembly

WARNING! Do not crawl under bumper unless it is properly supported on blocks or stands or the bumper may fall.

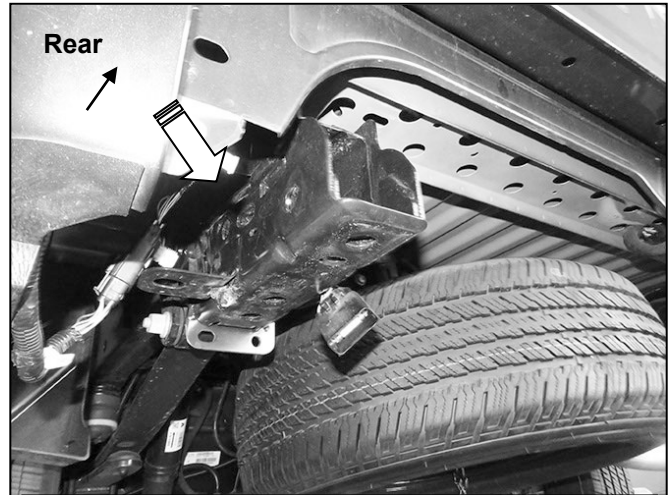

(Fig 2) Bumper assembly removed. Remove clip attaching harness to outside of frame (arrow)

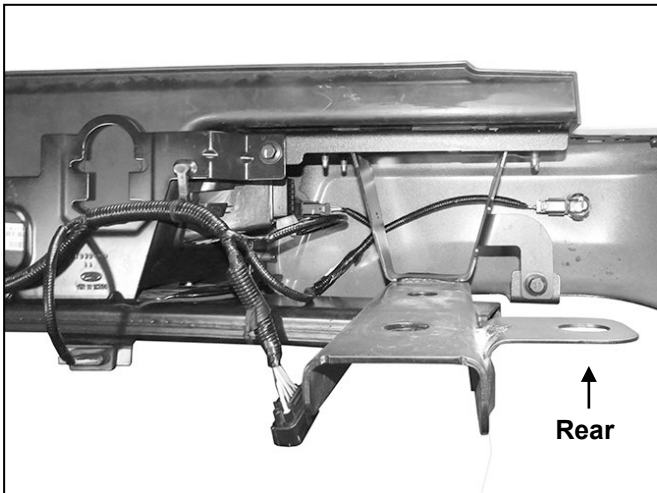

(Fig 3) Disassemble bumper to remove bumper reinforcement (pictured) or receiver hitch, wiring harness, sensors, license plate lights and trailer plug as equipped

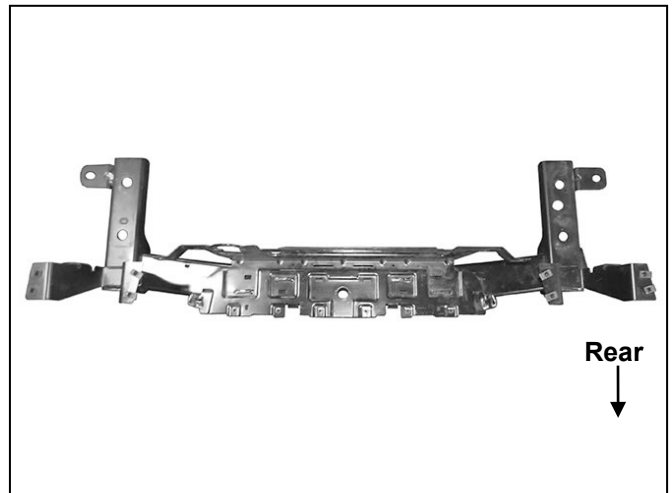

(Fig 4) Remove bumper reinforcement (pictured) or receiver hitch from bumper

Driver/left Side Installation Pictured



(Fig 5) Insert 10mm Single Bolt Plate into open end of frame and out hole in side of frame

WARNING! Do not remove bumper bolts unless the bumper is properly supported on blocks or stands or the bumper may fall.

10mm Single Bolt Plate

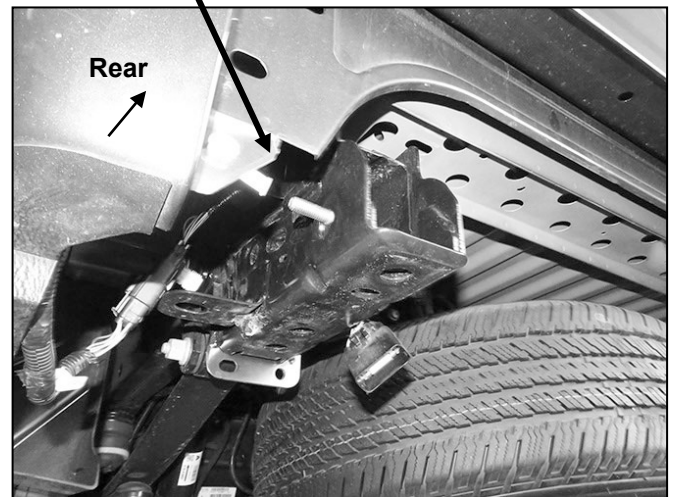

(Fig 6) Attach driver/left Frame Bracket to Bolt Plate

10mm Flat Washer
10mm Lock Washer
10mm Hex Nut

10mm Single Bolt Plate
10mm Plastic Retainer

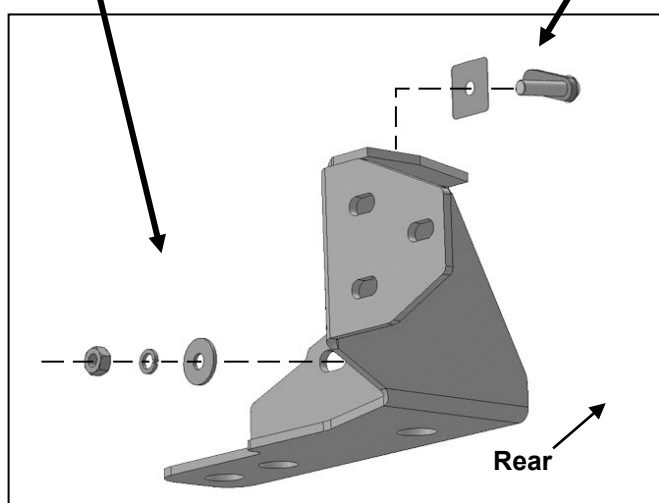

(Fig 7) Attach driver/left Mounting Bracket to Bolt Plate. Reuse factory hex bolts to attach bumper reinforcement or receiver hitch to bottom of Brackets and frame

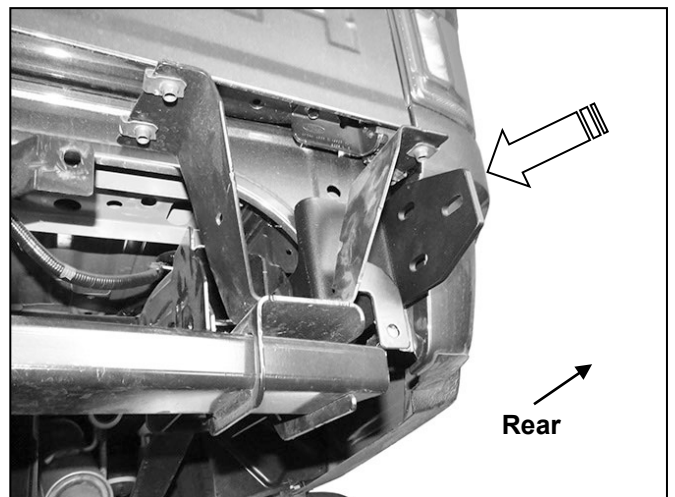

(Fig 8) Passenger/right Bumper Bracket and factory bumper reinforcement installed

Driver/left Side Installation Pictured

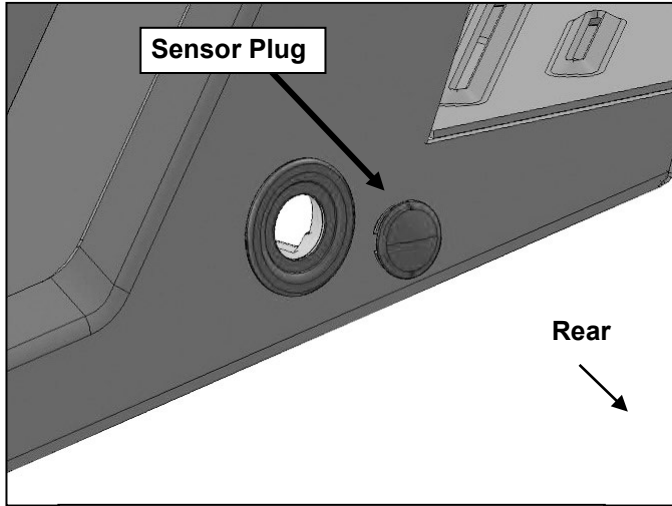

(Fig 9) Push sensor plug into mounting sleeve. Use of 4mm Screws is optional

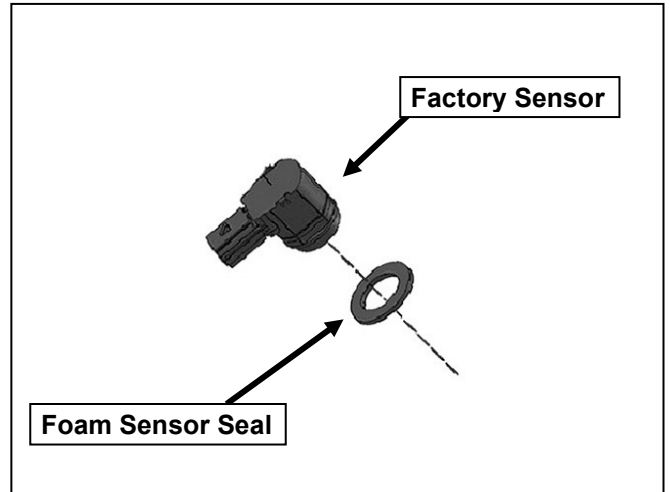

(Fig 10) Remove factory seal. Push Foam Seal onto end of sensor

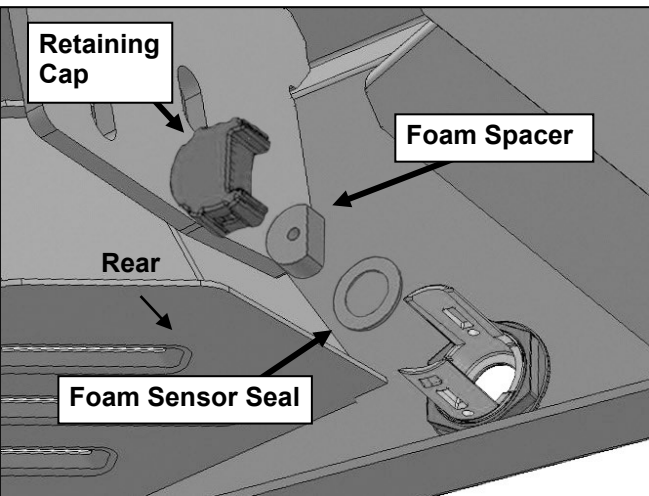

(Fig 11) Insert the sensor into the sensor sleeve

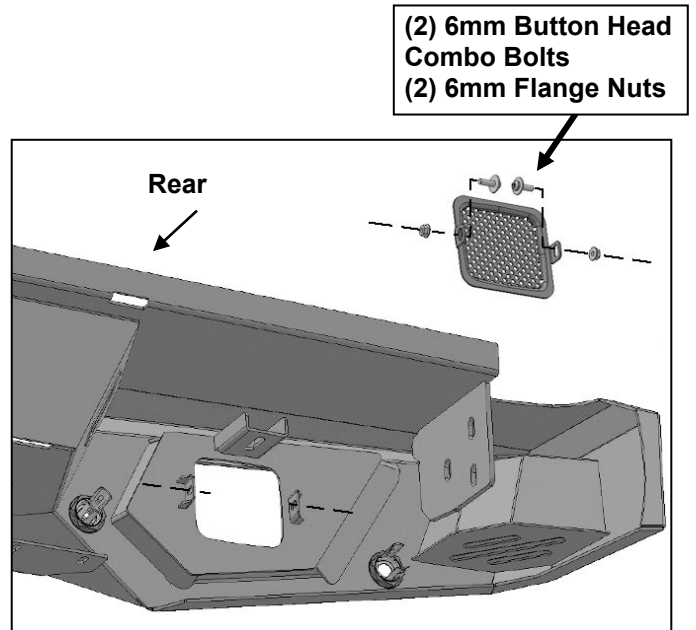

(Fig 12) Remove screens for additional access or to clear lights as needed

Driver/left Side Installation Pictured

WARNING! Do not crawl under bumper unless it is properly supported on blocks or stands or the bumper may fall.

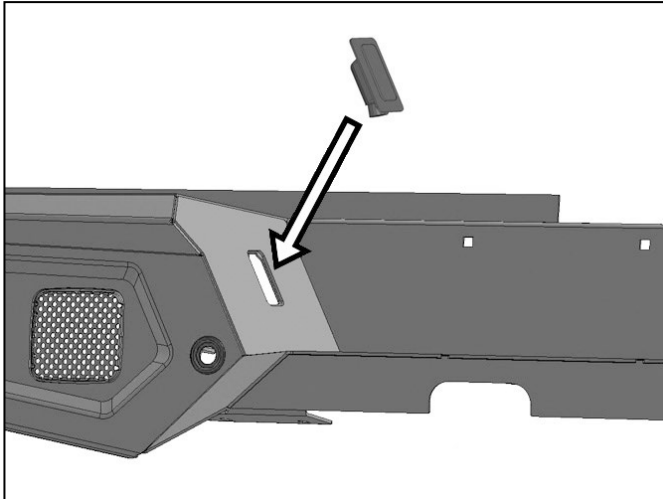

(Fig 13) Remove light from plastic mount. Push license plate light into Bumper

- (1) 10mm Bolt/Nut Plate
- (1) 10mm Hex Bolt
- (3) 10mm Flat Washers
- (3) 10mm Lock Washers
- (2) 10mm Hex Nuts

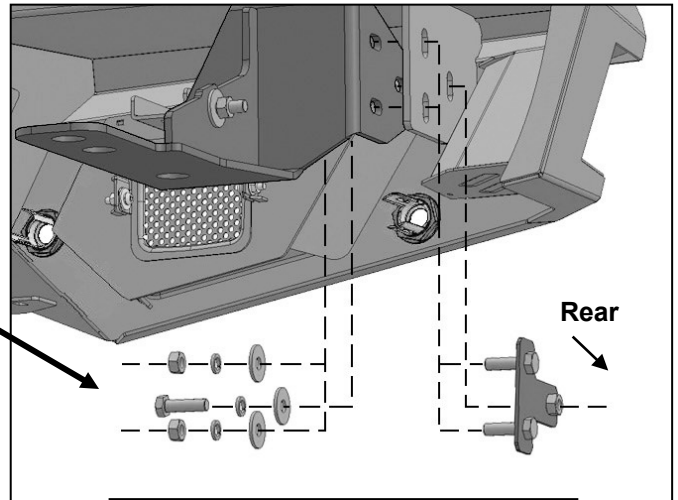

(Fig 14) Attach Bumper to Bracket with included 10mm Bolt/Nut Plate

- (2) 6mm x 20mm Button Head Screws
- (4) 6mm Flat Washers
- (2) 6mm Nylon Lock Nuts

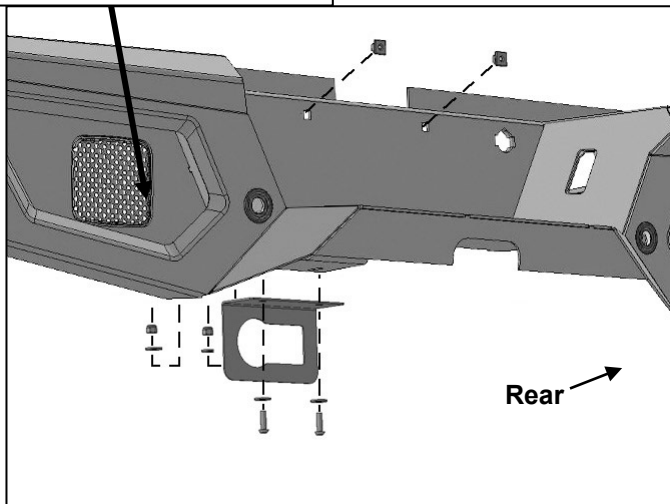

(Fig 15) Push plastic plugs into holes for license plate. Models with receiver hitch, attach towing harness Relocation Bracket to bottom of Bumper



Complete Installation