

REFERENCE J

Quick Installation Guide

MGP Caliper Cover

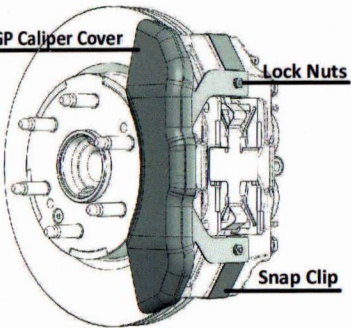

TOOLS REQUIRED

- 3/8 wrench
- .013 feeler gauge
(or included .013 paper strip)

IMPORTANT

- Clip baggies marked FRONT & REAR.
Keep separate.
- Space between wheel and face of caliper must be 1/8" min.

MGP Caliper Covers



1 Snap Clip

Place clip at an angle & engage the bottom leg inside of the brake caliper bracket.

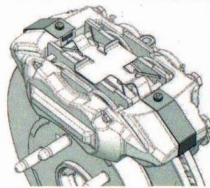
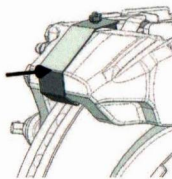
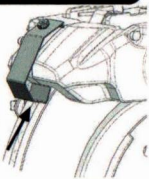

Push until clip snaps into place.

2 MGP Caliper Cover

Place bridges over studs and rotate down until the caliper cover snaps into place.

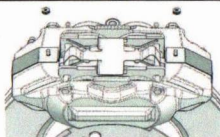

Remove lock nuts from snap clips.

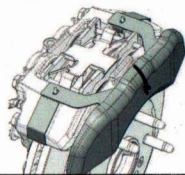
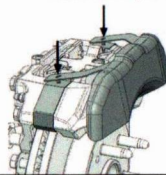

3 Lock Nuts

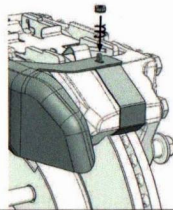
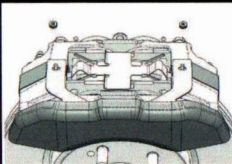

Install the supplied lock nuts onto the threaded studs to secure clip to bridge. Tighten with 3/8-inch wrench or socket to 25 in pounds. Do not overtighten nuts.

Troubleshooting Guide

IMPORTANT!

Use feeler gauge or the included paper strip to check clearance between clip and brake rotor. A gap of at least .013 inch (.32 mm) is recommended (enough to slide the paper strip in and out without sticking). Re-install wheel and use paper strip to check clearance on all sides of cover. Tighten lugnuts per manufacturer's specification.

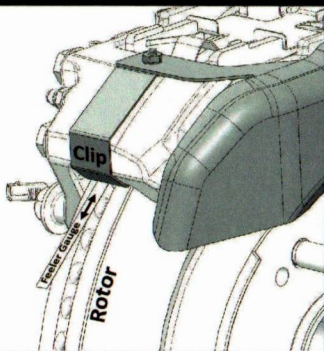

Caliper Cover should rest directly against the face of the brake caliper. The installer should verify that the bridges are set to 88° as depicted on image. Installer may adjust as needed.

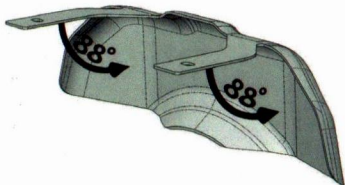

MGP Caliper Covers



Need Help?

- ✉ Email • TECH@CALIPERCOVERS.COM
- 📞 Tech Support • 1.877.995.0003 - Option 2

Scan the QR code for the installation instructions video

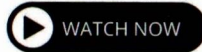

QR Code Scanner Not Working?

No worries! Find us on YouTube:

Just Search

"MGP Installation SN Style Clip: Reference J"