



BARRICADE

HEAVY DUTY RUNNING BOARDS
 09-18 DODGE RAM 1500 CREW CAB (INCL. 19-24 RAM 1500 CLASSIC)
 10-26 DODGE RAM 25-5500 CREW CAB (EXCL. CHASSIS CAB DIESEL MODELS)

PARTS LIST: HR1013

1	Driver/Left HD Running Board	4	8mm Bolt/Nut Plates
1	Passenger/Right HD Running Board	4	8mm Plastic Retainers
2	Driver/Left Front & Center Mount Bracket	14	8mm-1.25 x 30mm Hex Bolts
2	Passenger/Right Front & Center Mount Bracket	20	8mm x 24mm OD x 2mm Flat Washers
1	Driver Rear Mounting Bracket	8	8mm Lock Washers
1	Passenger Rear Mounting Bracket	4	8mm-1.25 Hex Nuts
3	Driver/Left Support Brackets	6	8mm-1.25 Nylon Lock Nuts
3	Passenger/Right Support Brackets	6	6mm Double Bolt Plates
4	12mm-1.75 x 40 Bolt Plates	12	6mm-1.0 x 25mm Hex Bolts
4	12mm Plastic Retainers	36	6mm x 22mm x 2mm Flat Washers
4	12mm x 32mm OD x 3mm Flat Washers	12	6mm Lock Washers
4	12mm Lock Washers	12	6mm Hex Nuts
4	12mm-1.75 Hex Nuts	12	6mm Nylon Lock Nuts

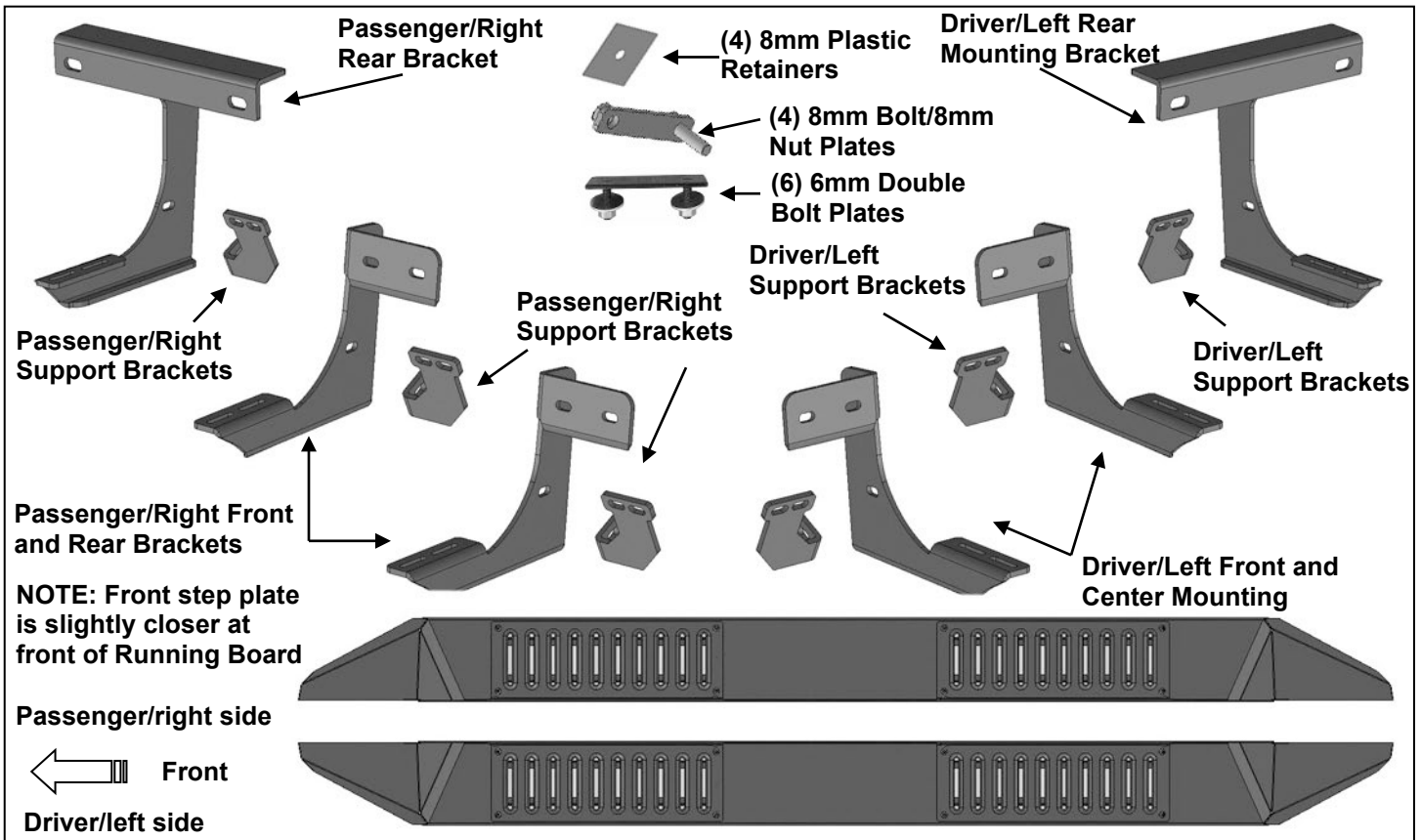

PROCEDURE:

1. REMOVE CONTENTS FROM BOX. VERIFY ALL PARTS ARE PRESENT. READ INSTRUCTIONS CAREFULLY BEFORE STARTING INSTALLATION. DRILLING MAY BE REQUIRED.
2. Starting at the passenger side-front of the vehicle, remove the sealing tape covering the factory holes in the side of the inner panel, (Figure 1).
3. Determine the correct procedure to attach the driver side front Bracket for your model/year:
Models without factory threaded inserts in body panel:

- a. Partially thread an 8mm Hex Bolt onto the threaded end of a 8mm Bolt and Nut Plate, **(Figure 2)**. Thread the Hex Bolt in until it is flush with the welded nut, **(Figure 3)**. Use the Hex Bolt as a handle and insert the Bolt and Nut Plate into the oval hole, **(Figure 4)**. Feed the threaded bolt on the Bolt Plate through one of the hex shaped factory holes. Thread (1) 8mm Plastic Retainer onto the threaded end and down tight against the body panel, **(Figure 5)**. **NOTE:** The Plastic Retainer is designed to keep the Bolt/Nut Plate from falling into the body panel and to aid in Bracket installation.
- b. Select a passenger side front or center Mounting Bracket, **(Figure 6)**. Attach the Bracket to the threaded end of the Bolt Plate with (1) 8mm Flat Washer, (1) 8mm Lock washer and (1) 8mm Hex Nut, **(Figure 7)**. Do not tighten at this time.
- c. Remove the 8mm Hex Bolt from the nut on the Bolt Plate from **Step 3a**. Rotate the Bolt on the Bolt Plate until the threaded nut lines up with the remaining hole in the Mounting Bracket and body panel, **(Figures 7 & 8)**. Attach the Bracket to the threaded Nut Plate with (1) 8mm x 30mm Hex Bolt, (1) 8mm Lock Washer and (1) 8mm Flat Washer, **(Figure 8)**. Do not fully tighten hardware at this time.

Models with factory threaded inserts:

- a. Attach the passenger side Front Bracket directly to the threaded inserts with (2) 8mm x 30mm Hex Bolts, (2) 8mm Lock Washers and (2) 8mm Flat Washer, **(Figures 9 & 10)**. Leave hardware loose.
4. Next, select (1) passenger side Support Bracket. Attach the Bracket to the front facing side of the front Bracket with (1) 8mm x 30mm Hex Bolt, (2) 8mm Flat Washers and (1) 8mm Nylon Lock Nut, **(Figure 11)**. Rotate the Support Bracket to the back of the pinch weld. Line up the slots in the top of the Support Bracket with the (2) factory holes in the pinch weld. Attach the Bracket to the back of the pinch weld with (2) 6mm x 25mm Hex Bolts, (4) 6mm Flat Washers and (2) 6mm Nylon Lock Nuts, **(Figures 12 & 13)**. Do not fully tighten hardware at this time. **IMPORTANT:** 2009-12 models are not equipped with factory holes and will require drilling through the pinch weld to attach the Support Bracket. Do not drill through pinch weld at this time, **(see Step 11)**.
5. Move along the side of the body panel to the center mounting location, **(Figure 1)**. Repeat **Steps 2—4** to install the passenger side center Mounting and Support Brackets.
6. Move toward the rear location, **(Figure 1)**. Remove the sealing tape covering the (2) factory oval holes. Select (1) 12mm x 40mm Bolt Plate and (1) 12mm Plastic Retainer. Partially thread the Retainer onto the Bolt Plate, **(Figure 14)**. Insert the Bolt Plate into the forward oval hole. Thread the Retainer down tight against the body panel, **(Figure 15)**. Repeat to install the 2nd Bolt Plate in the remaining factory hole.
7. Select the passenger side Rear Mounting Bracket, **(Figure 16)**. Attach the Bracket to the (2) Bolt Plates with (2) 12mm Flat Washers, (2) 12mm Lock Washers and (2) 12mm Hex Nuts, **(Figures 17 & 18)**. Do not tighten hardware.
8. Repeat **Step 4** to attach (1) passenger side Support Bracket to the Rear Bracket, **(Figure 18)**.
9. Select the passenger/right Running Board. **NOTE:** Use the illustration on **Page 1** to properly identify the passenger side Running Board. Place the Running Board on top of the Brackets. Locate the channels in the bottom of the Running Board. Select (3) 6mm Double Bolt Plates, **(Figure 19)**. Insert the Bolt Plates into the channels in the bottom of the Running Board closest to the Brackets, **(Figure 20)**. Lift the Running Board up and guide the studs through the Brackets.
10. Attach the Running Board to the Brackets with (6) 6mm Flat Washers, (6) 6mm Lock Washers and (6) 6mm Hex Nuts, **(Figure 22)**. **NOTE:** The Running Board is designed to fit close to the vehicle. It may be necessary to loosen the Bracket hardware and tilt the Brackets downward to insert the Running Board between the Brackets and the body. Do not tighten hardware at this time.
11. Properly level and adjust the Running Board and fully tighten all hardware.

Drilling instructions for all Support Brackets:

- a. Make sure the Running Board is level to the vehicle. Adjust and tighten all mounting hardware.
- b. Line up the slots on the Support Brackets with the back of the pinch weld. Mark the location of the slots onto the pinch weld.

- c. Drill (2) 1/4" holes through the pinch weld for each Support Bracket. **IMPORTANT:** Do not drill too close to the bottom edge of the pinch weld. Adjust the Brackets as necessary to move the slots up the body panel away from the edge. Drill the holes toward the outside of the slots.
 - d. Attach each Support Bracket to the pinch weld with (2) 6mm Hex Bolts, (4) 6mm Flat Washers and (2) 6mm Nylon Lock Nuts, (**Figures 13 & 21**). Check for level then tighten all hardware.
12. Move to the driver side of the vehicle. Repeat **Steps 2—11** for driver side installation.
13. Do periodic inspections to the installation to make sure that all hardware is secure and tight.

To protect your investment, wax this product after installing. Regular waxing is recommended to add a protective layer over the finish. Do not use any type of polish or wax that may contain abrasives that could damage the finish. Aluminum polish may be used to polish small scratches and scuffs on the finish. Mild soap may be used also to clean the Running Boards.

Passenger Side Installation Pictured

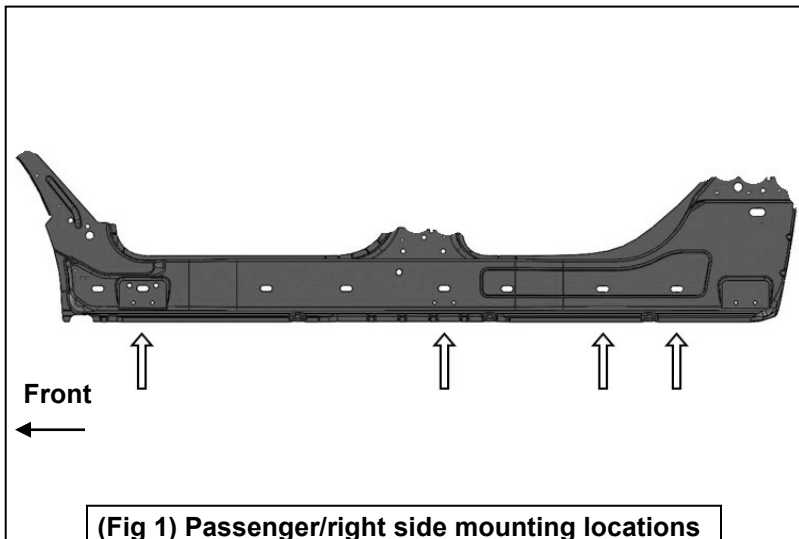

(Fig 1) Passenger/right side mounting locations (arrows) illustrated from back of body panel

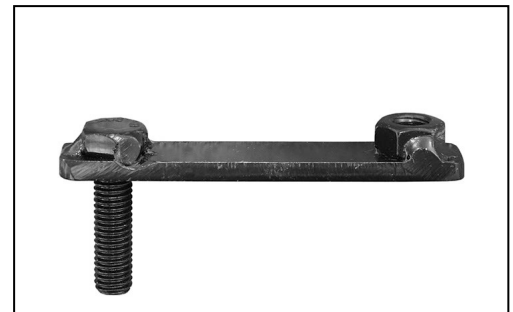

(Fig 2) 8mm Bolt-8mm Nut Plate, NOTE: 8mm Bolt-Nut Plate is not required on models with factory threaded inserts

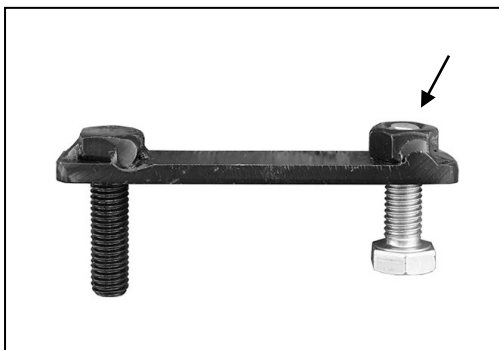

(Fig 3) Thread (1) 8mm Hex Bolt into the nut on the plate. Stop when bolt reaches end of nut as pictured

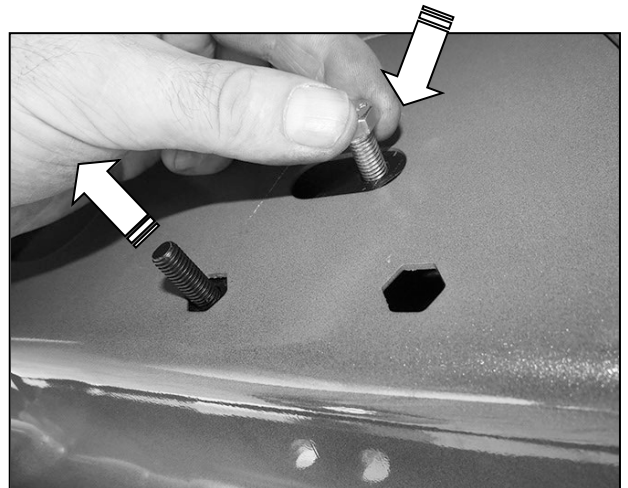

(Fig 4) Use the loose Hex Bolt as a handle. Insert the Bolt Plate into the oval hole and feed the threaded end out either factory hex shaped hole. **IMPORTANT:** Do not let go of the hex bolt until after Plastic Retainer has been threaded onto bolt (Fig 5)

Passenger Side Installation Pictured

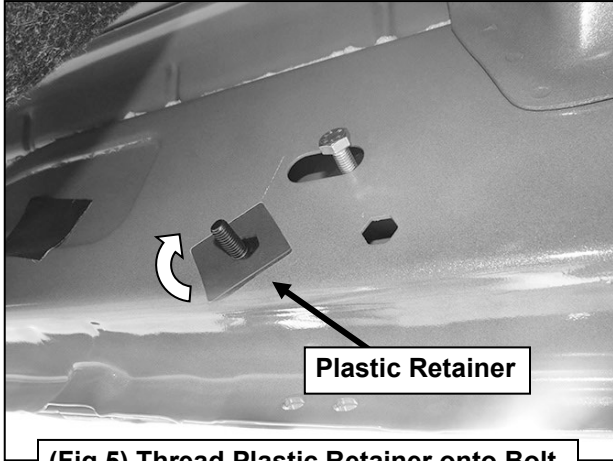

(Fig 5) Thread Plastic Retainer onto Bolt Plate to hold Bolt Plate in position.

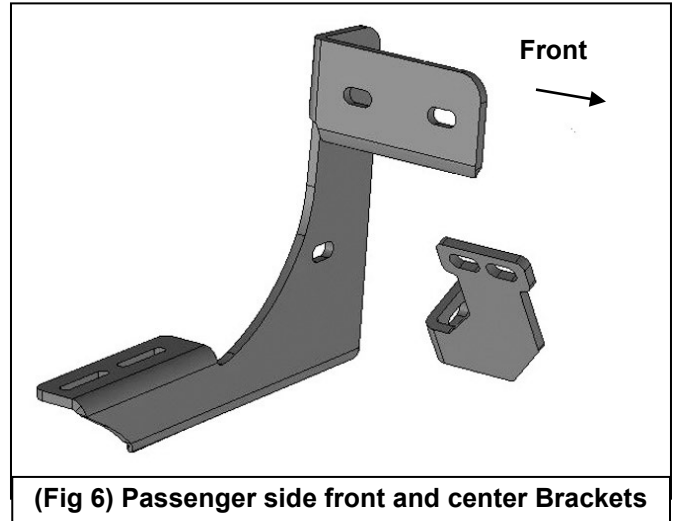

(Fig 6) Passenger side front and center Brackets

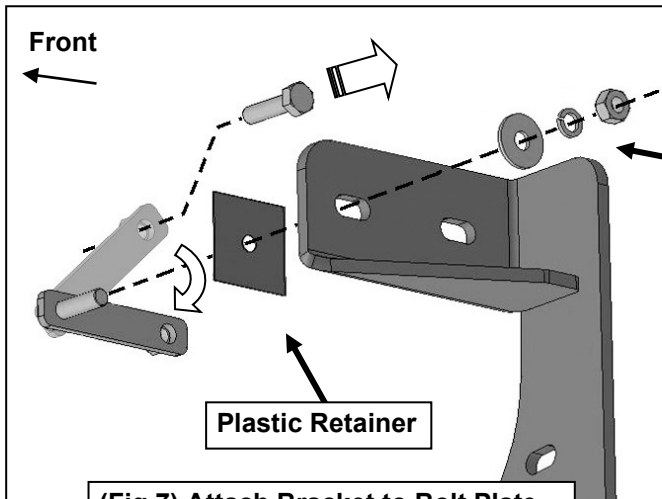

(Fig 7) Attach Bracket to Bolt Plate

8mm Flat Washer
 8mm Lock Washer
 8mm Hex Nut

Remove Hex Bolt, rotate Bolt/Nut Plate to line up threaded nut with body panel and Mounting Bracket (see Fig 7)

8mm Hex Bolt
 8mm Lock Washer
 8mm Flat Washer

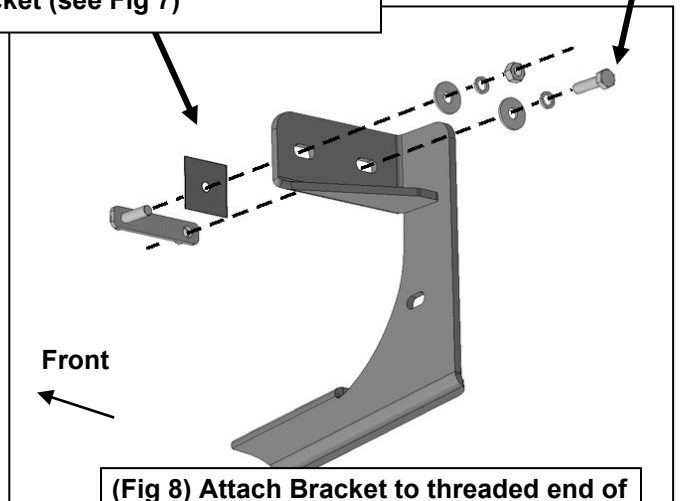

(Fig 8) Attach Bracket to threaded end of Bolt Plate first. Remove 8mm Hex Bolt (see Fig 3). Rotate Bolt Plate to line up with remaining factory hex shaped hole.

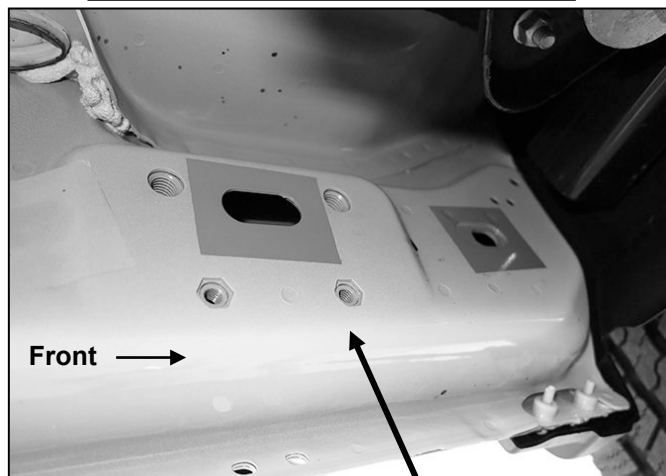

(Fig 9) Driver side front mid 2015-on, an example of models with factory installed threaded inserts

Passenger Side Installation Pictured

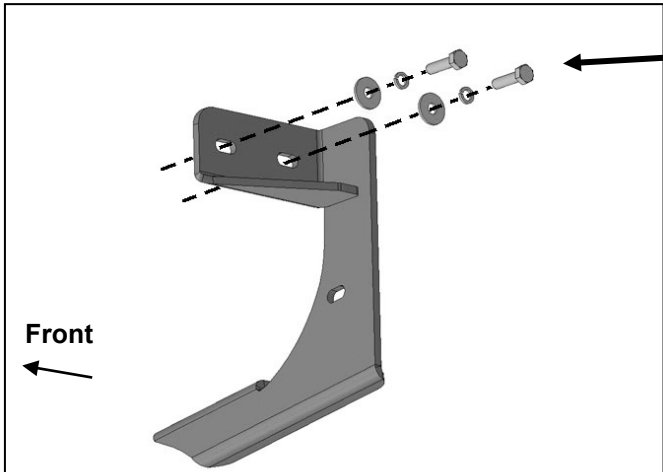

- (2) 8mm Hex Bolts
- (2) 8mm Lock Washers
- (2) 8mm Flat Washers

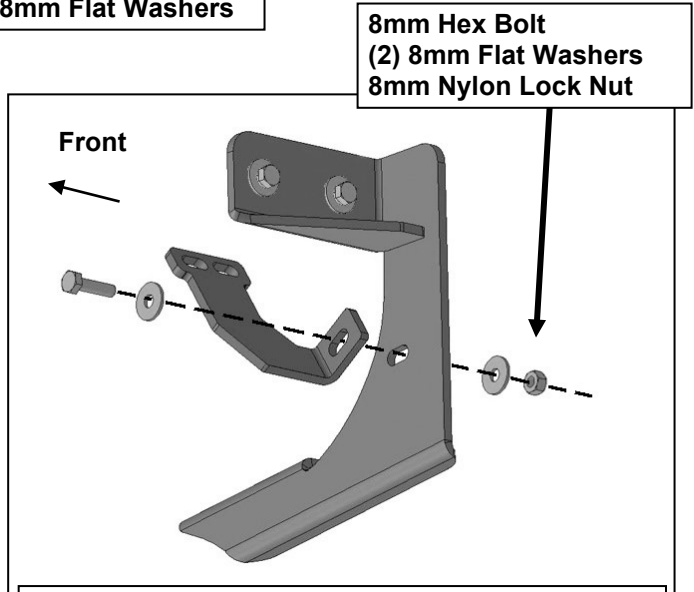

- 8mm Hex Bolt
- (2) 8mm Flat Washers
- 8mm Nylon Lock Nut

(Fig 11) Attach Driver/Left front Support Bracket to front facing side of Mounting Bracket

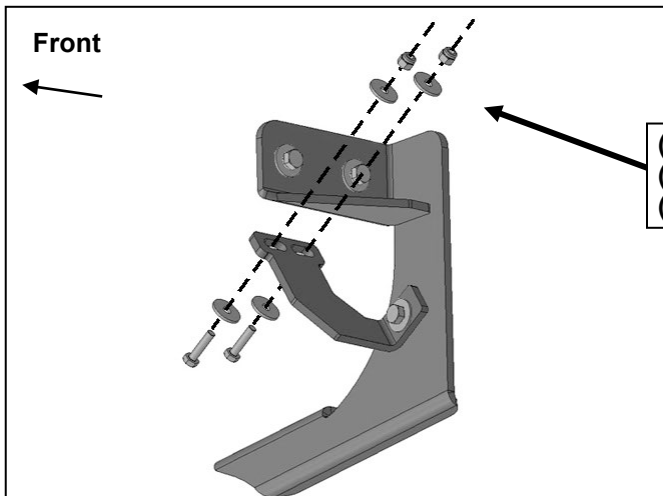

- (2) 6mm Hex Bolts
- (4) 6mm Flat Washers
- (2) 6mm Nylon Lock Nuts

(Fig 12) Attach Support Bracket to back of pinch weld (models with factory holes in pinch weld only)

IMPORTANT: 2009-2012 models without holes in pinch weld will require drilling 1/4" holes through pinch weld to attach driver side front support bracket. Do complete installation of sidebars first, level sidebar before drilling holes for support bracket.

- (2) 6mm Hex Bolts
- (4) 6mm Flat Washers
- (2) 6mm Nylon Lock Nuts

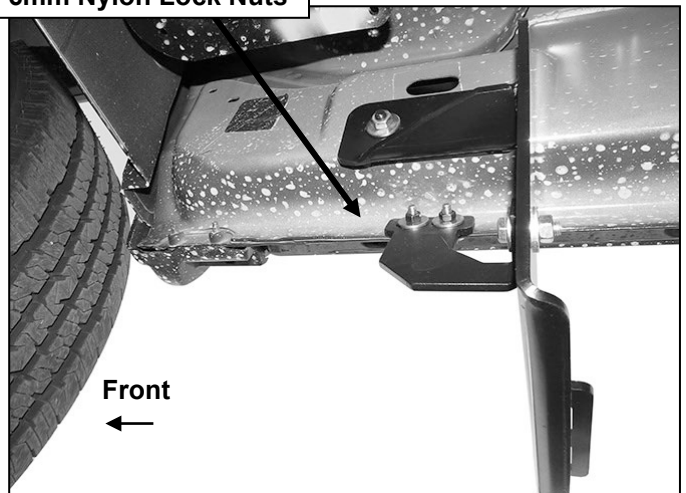

(Fig 13) Passenger side front Bracket assembly

Passenger Side Installation Pictured

Partially thread Plastic Retainer onto Bolt Plate

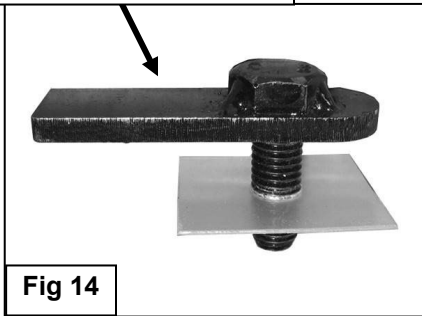

Bolt Plate with Retainer

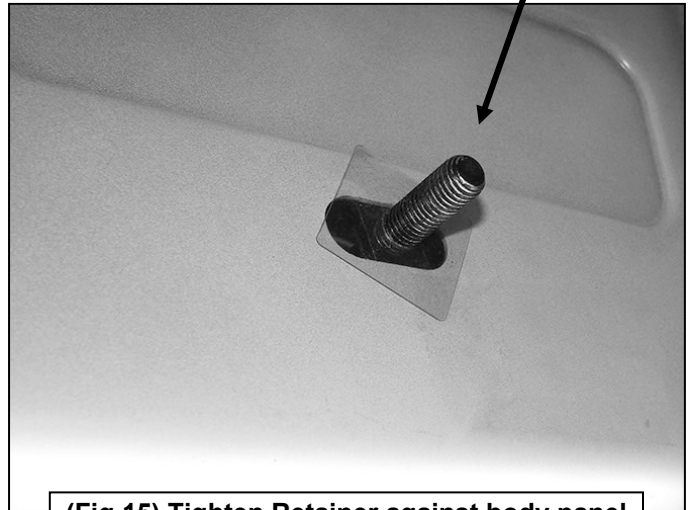

(2) 12mm Flat Washers
(2) 12mm Lock Washers
(2) 12mm Hex Nuts

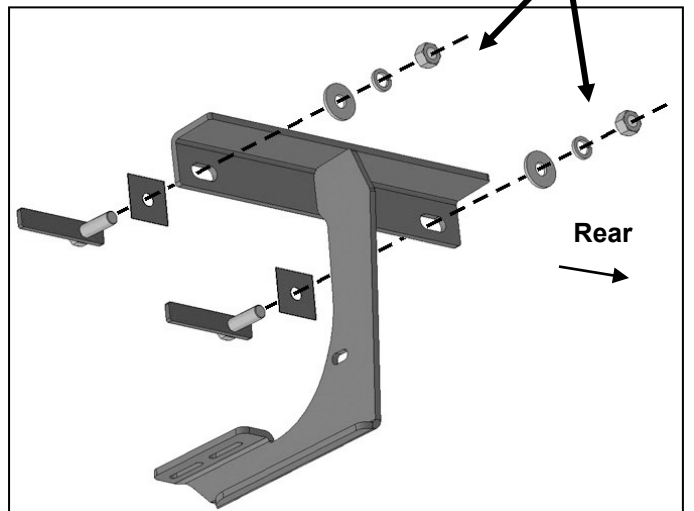

IMPORTANT: All models will require drilling 1/4" holes through pinch weld to attach rear support brackets. Do complete installation of Running Board first, level Running Board and mark hole locations before drilling holes for support bracket. Do not drill close to edge of pinch weld.

Passenger Side Installation Pictured

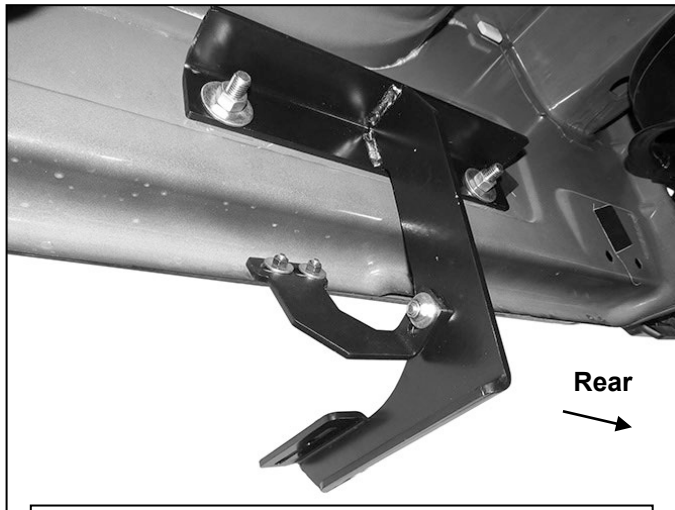
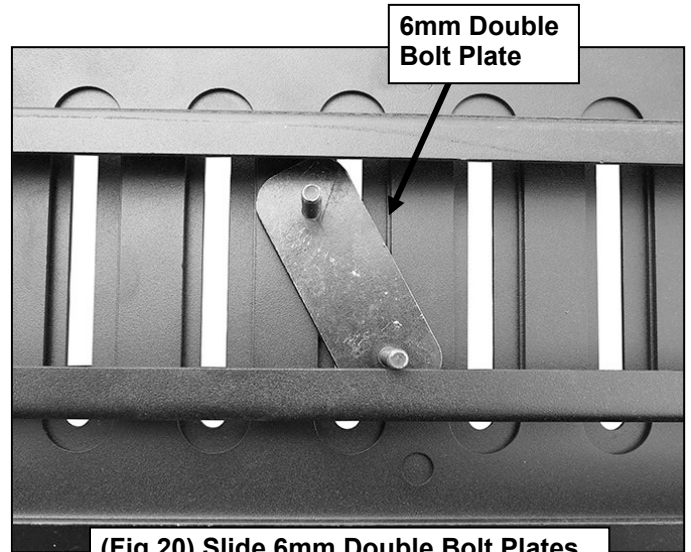

- 6mm Double Bolt Plate
- (2) 6mm Flat Washers
- (2) 6mm Lock Washers
- (2) 6mm Hex Nuts



IMPORTANT: All models will require drilling 1/4" holes through pinch weld to attach rear support brackets. Do complete installation of Running Board first, level Running Board and mark hole locations before drilling holes for support bracket. Do not drill close to edge of pinch weld.