



TEL: 1-866-XANATOS

INSTALLATION INSTRUCTIONS

**MODULAR RUGGED GRILLE GUARD FOR
10-19 Dodge Ram 2500/3500**

PART# RU-DORA10-B

PARTS LIST:

| | | | |
|---|-------------------------------------|----|---|
| 1 | Main Body | 18 | 8mm x 24mm x 2mm Flat Washers |
| 1 | Driver/Left Brush Guard | 10 | 8-1.25mm x 25mm Button Head Bolts |
| 1 | Passenger/Right Brush Guard | 8 | M8-1.25mm Nylon Lock Nuts |
| 2 | LED lamp Bracket | 6 | 12mm x 24mm OD x 2.5mm Flat Washers |
| 2 | Frame Brackets | 6 | 12mm Lock Washers |
| 1 | Driver/Left Mounting Bracket | 6 | 12-1.75mm Hex Nuts |
| 1 | Passenger/Right Mounting Bracket | 6 | 10-1.50mm x 30mm Hex Bolts |
| 1 | 2014-15 Driver/Left Top Bracket | 12 | 10mm x 27mm OD x 3mm Flat Washers |
| 1 | 2014-15 Passenger/Right Top Bracket | 6 | 10mm Lock Washers |
| 1 | 2016-17 Driver/Left Top Bracket | 6 | 10-1.50mm Hex Nuts |
| 1 | 2016-17 Passenger/Right Top Bracket | 6 | 8-1.25mm x 30mm Hex Bolts |
| 2 | 12-1.75mm x 30mm Double Bolt Plates | 6 | 8mm x 16mm OD x 1.6mm Flat Washers |
| 2 | 12-1.75mm x 35mm Single Bolt Plates | 6 | 8mm Lock Washers |
| 1 | 5mm Allen Wrench | 2 | 50mm x 250mm Adhesive Backed Foam Tapes |

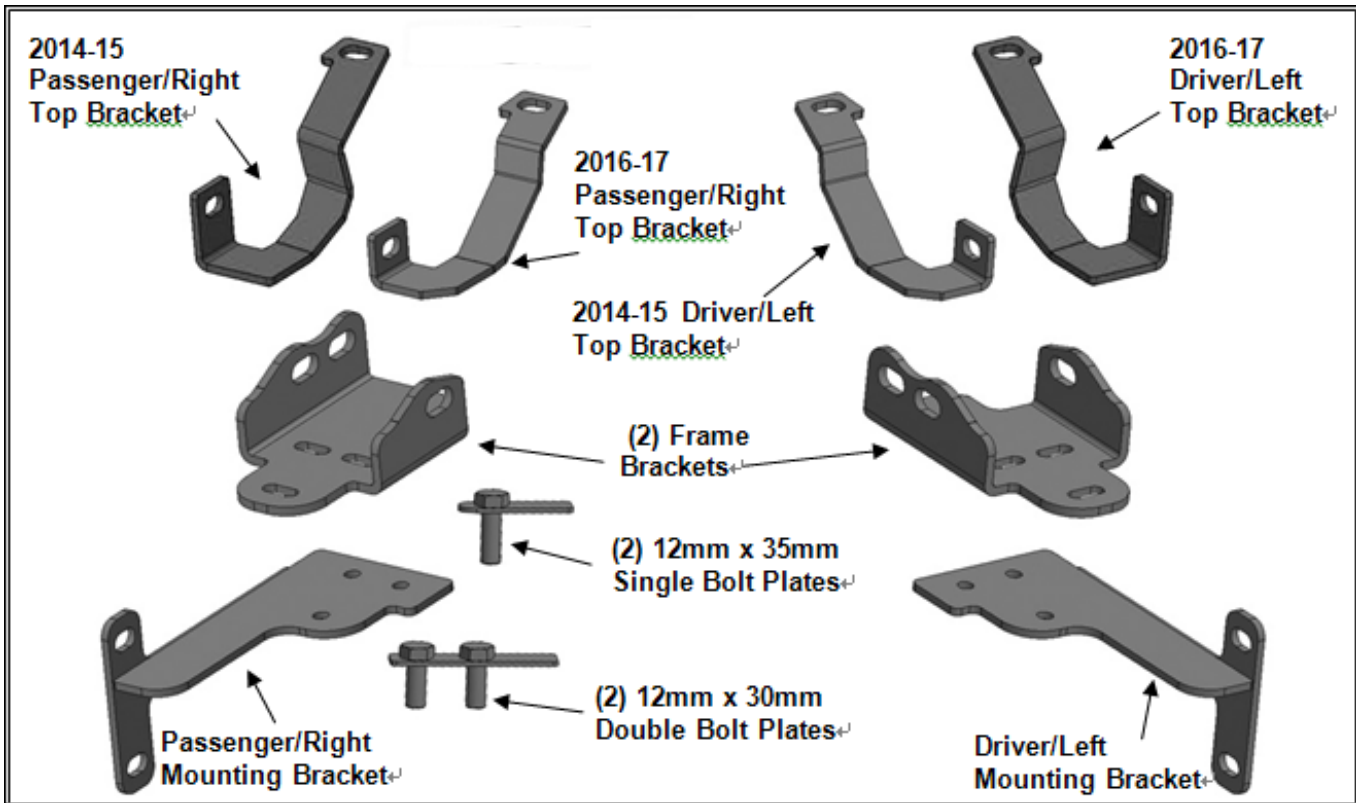

(2)LED lamp Bracket

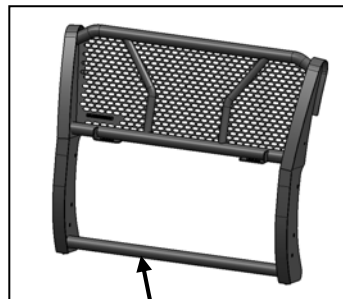

Main Body

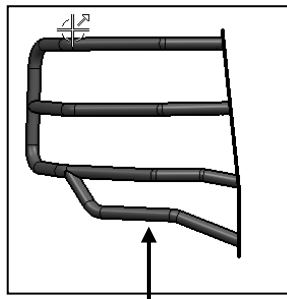

Passenger/Right Brush Guard

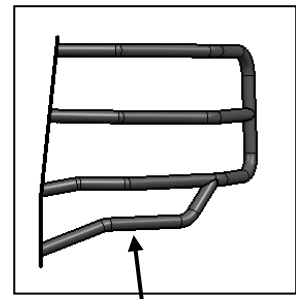

Driver/Left Brush Guard

Please Noted:

1. Before you install the Grille Guard on the vehicle, please install the Driver/Left Brush Guard and Passenger/Right Brush Guard on the main body first.
2. Before you install the LED Lamp on the main body please install the LED Lamp Bracket first.
3. If you are not going to install a LED Lamp, the LED Lamp Bracket installation is unnecessary. For main body installation follow the instruction as bellow.

Passenger/Right Brush Guard

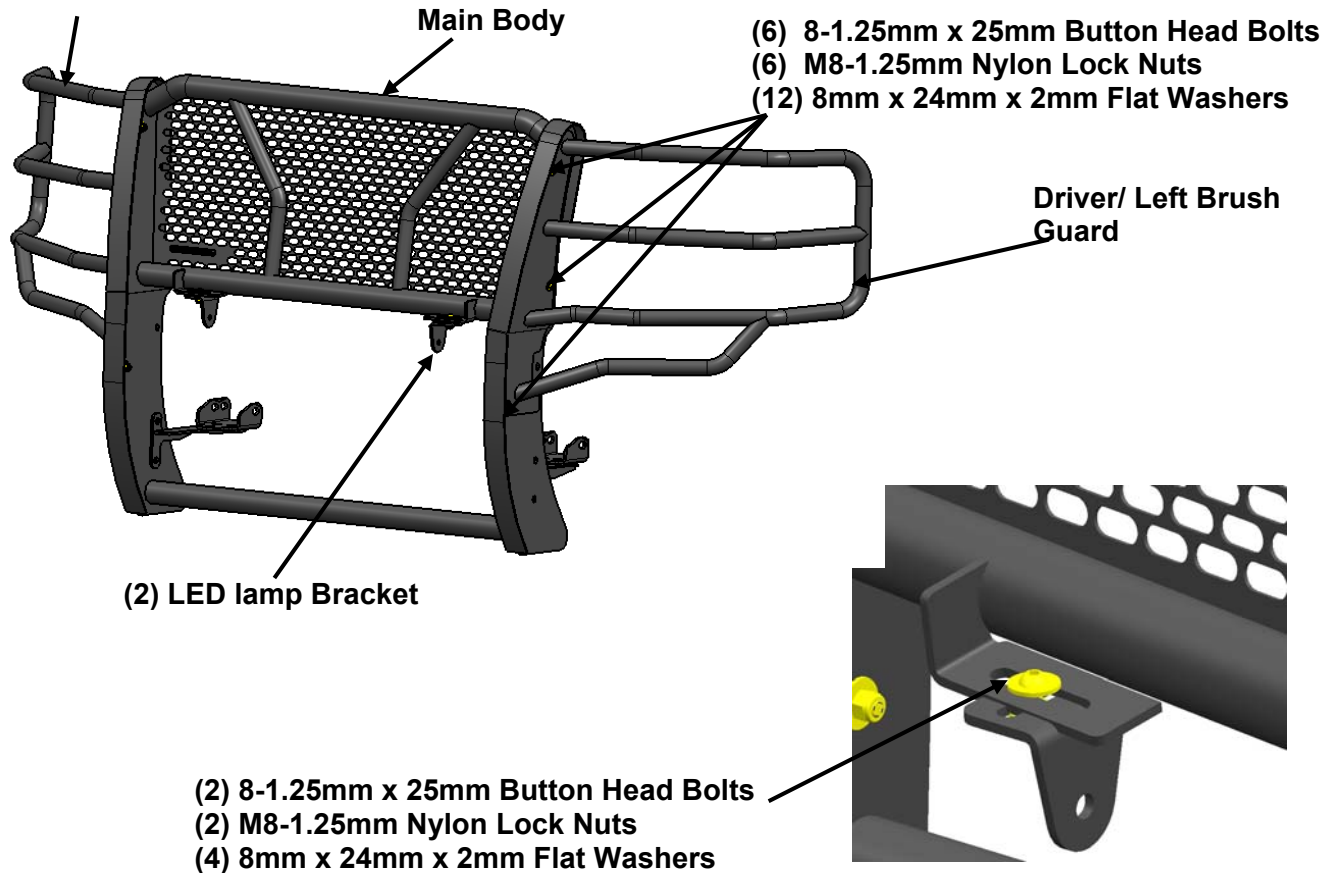

PROCEDURE:

REMOVE CONTENTS FROM BOX AND VERIFY ALL PARTS ARE PRESENT. READ INSTRUCTIONS CAREFULLY. CUTTING MAY BE REQUIRED. ASSISTANCE IS HIGHLY RECOMMENDED. INSTALLATION MAY INTERFERE WITH FRONT MOUNTED SENSORS.

1. Open the hood and remove the cover between the top of the radiator and the grille, **(Figure 1)**. Remove the hardware attaching the grille at the top and bottom.
2. On **2014-15 models**, from behind the bumper, release the clips and hardware to remove the plastic body panel, (fascia), on top of the bumper between the bottom of the grille and the top of the bumper, **(Figure 3)**. For **all models**, carefully remove the grille from the vehicle. **NOTE:** Grille is held in place with screws at the top and several clips, **(Figure 2)**. Remove the screws and firmly pull the grille straight out from the vehicle to release the grille from clips, **(Figures 4—6)**.
3. Depending on the year of the vehicle, select either the 2014-15 Driver/Left Top Bracket or the 2016-17 Driver/Left Top Bracket, **(Figure 7)**. Apply a layer of Adhesive Backed Foam Tape to the backside of the Top Bracket to protect the finish on the bumper, **(Figure 7)**. **IMPORTANT:** To prevent the Top Brackets from damaging the finish on the vehicle during installation, also cover the top of the bumper with removable tape, (masking tape). Re-use the Bumper Bolt hardware to attach the Top Bracket to the top of the bumper bracket, **(Figure 8)**. Leave hardware loose at this time.

4. Remove factory tow hook and hardware if equipped. **IMPORTANT:** Tow hooks cannot be reinstalled with the Grille Guard. It is **not** necessary to remove the bumper, only loosen the hardware enough to rotate the bumper to remove the long hex bolts from the tow hooks, (**Figure 11**).

Vehicles without tow hooks:

- a. Cut out the indented area in both sides of the plastic bumper insert to clear the Brackets as pictured, (**Figures 9 & 10**). **IMPORTANT:** Make several small cuts for best fit. Do not cut through the top edge of the panel.
5. Select (1) Frame Bracket, (**Figure 12**). Insert the Frame Bracket through the opening in the bumper, (**Figure 13**). Line up the holes in the Bracket with the holes in the end of the frame for the tow hook. Select (1) 12mm Double Bolt Plate, (**Figure 14**). Insert the Double Bolt Plate into the end of the frame, through the (2) holes in the side of the frame and out through the Frame Bracket, (**Figure 15**). Secure the Frame Bracket to the Bolt Plate with (2) 12mm Flat Washers and (2) 12mm Lock Washers and (2) 12mm Hex Nuts. Snug but do not fully tighten hardware at this time.
 6. Select (1) 12mm Single Bolt Plate, (**Figure 16**). Attach the Frame Bracket to the Bolt Plate with (1) 12mm Flat Washer, (1) 12mm Lock Washer and (1) 12mm Hex Nut, (**Figure 17**). Do not tighten at this time.
 7. Next, select the driver side Mounting Bracket. Attach the Mounting Bracket to the bottom of the Frame Bracket with (3) 8mm x 30mm Hex Bolts, (3) 8mm Lock Washers and (3) 8mm Flat Washers, (**Figures 18 & 19**). Do not tighten hardware at this time.
 8. Repeat **Steps 3—7** to install the passenger side Brackets.
 9. With assistance, hold the Grille Guard up in position on the outside of the Mounting Brackets. Attach the Grille Guard to the Brackets with (6) 10mm Hex Bolts, (12) 10mm Flat Washers, (6) 10mm Lock Washers and (6) 10mm Hex Nuts, (**Figure 20**). Do not tighten hardware at this time.
 10. Check the Grille guard alignment with the vehicle. Adjust as required then tighten the Frame Bracket hardware. Do not fully tighten the Grille Guard to Bracket hardware at this time.
 11. Level and adjust the Grille Guard and fully tighten all hardware.
 12. Reinstall the fascia if removed, the grille and the top plastic cover.
 13. Do periodic inspections to the installation to make sure that all hardware is secure and tight.

To protect your investment, wax this product after installing. Regular waxing is recommended to add a protective layer over the finish. Do not use any type of polish or wax that may contain abrasives that could damage the finish. **Use** mild soap to clean the Grille Guard.

Driver Side Mounting Bracket Installation Pictured

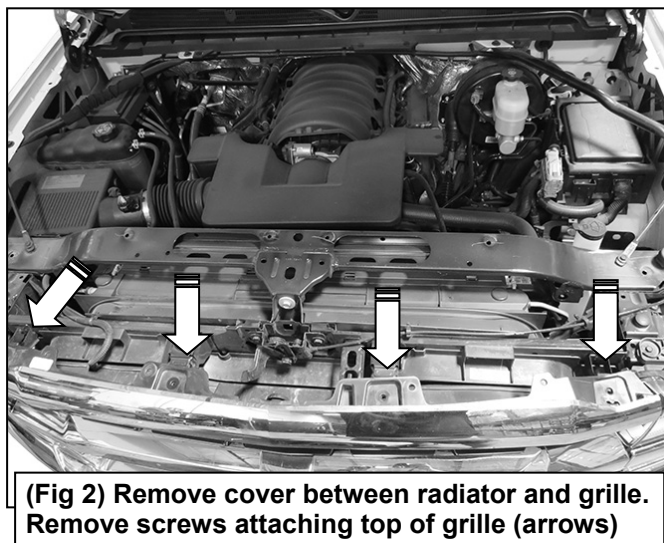

Driver Side Mounting Bracket Installation Pictured

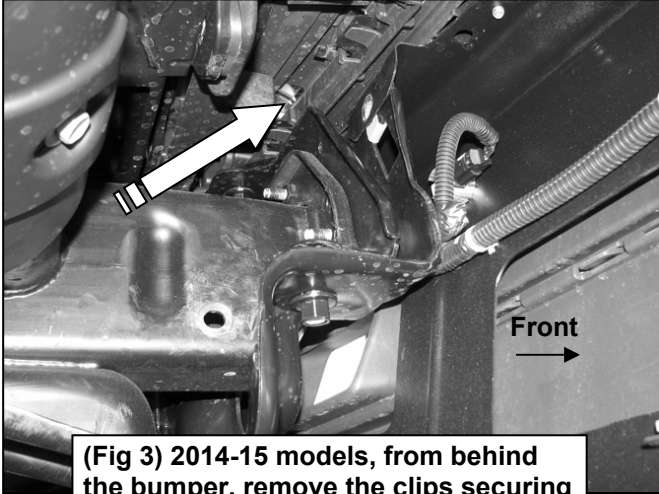

(Fig 3) 2014-15 models, from behind the bumper, remove the clips securing the fascia to the top of the bumper



(Fig 4) Firmly pull grille straight out from vehicle

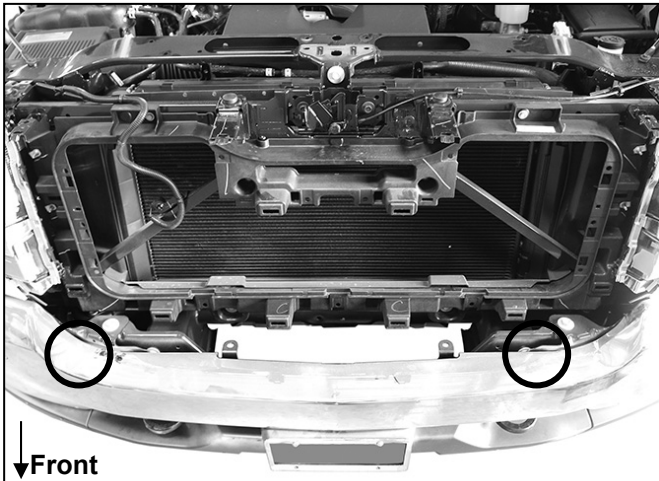

(Fig 5) Grille removed to access top bumper bolts

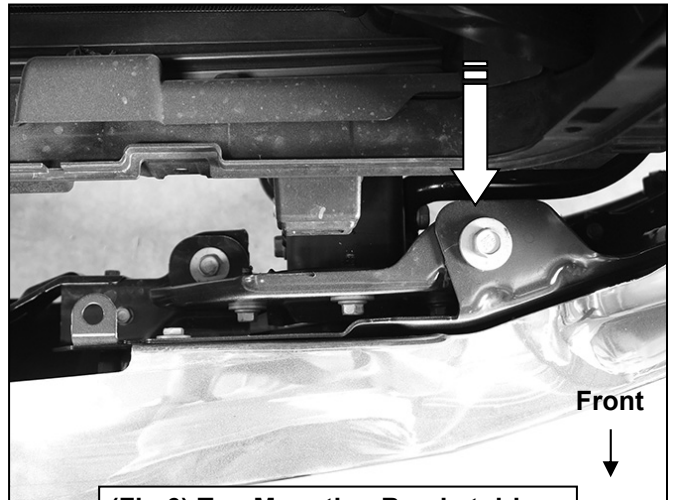

(Fig 6) Top Mounting Bracket driver side mounting location from above

2014-15 Driver side Top Mounting Bracket

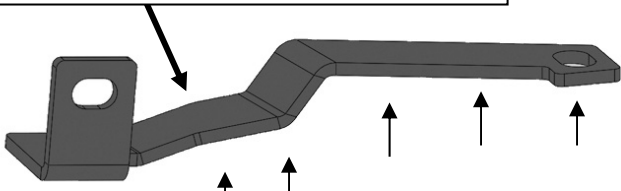

2016-17 Driver side Top Mounting Bracket

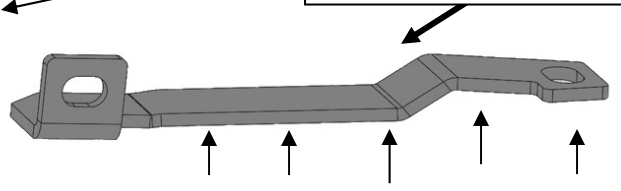

(Fig 7) Apply Adhesive Backed Foam Tape to the underside of Top Mounting Bracket

Driver Side Mounting Bracket Installation Pictured

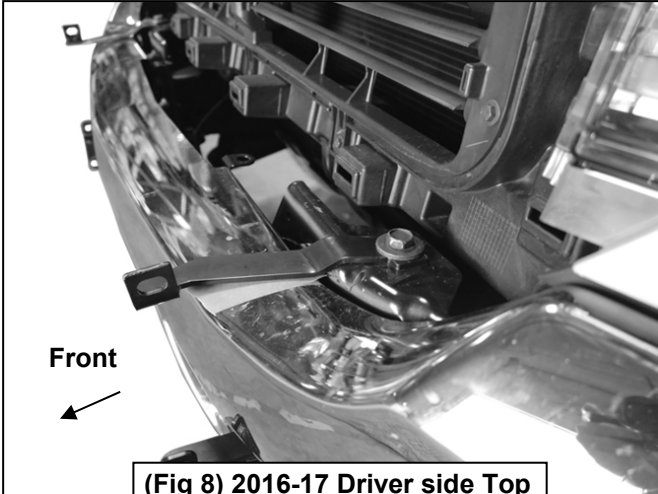

(Fig 8) 2016-17 Driver side Top Mounting Bracket installed

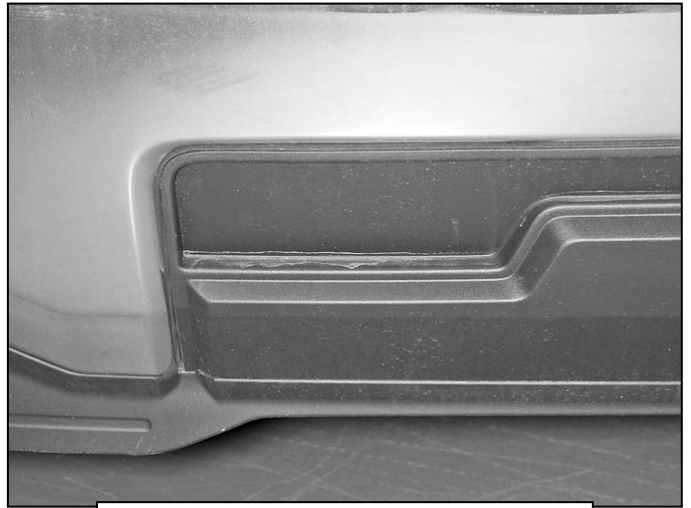

(Fig 9) "No tow hook" model pictured

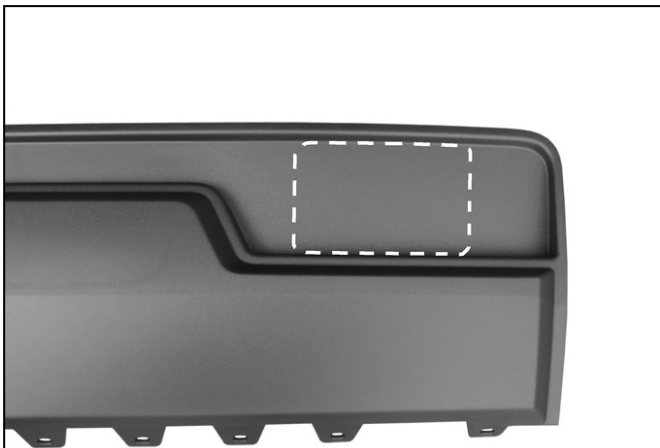

(Fig 10) Driver side illustrated for example only

Loosen bumper bolts enough to rotate bumper to remove long hex bolt from tow hooks

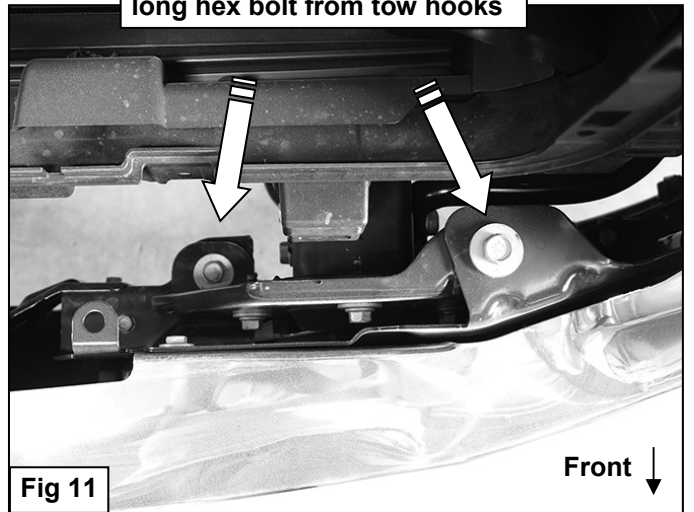
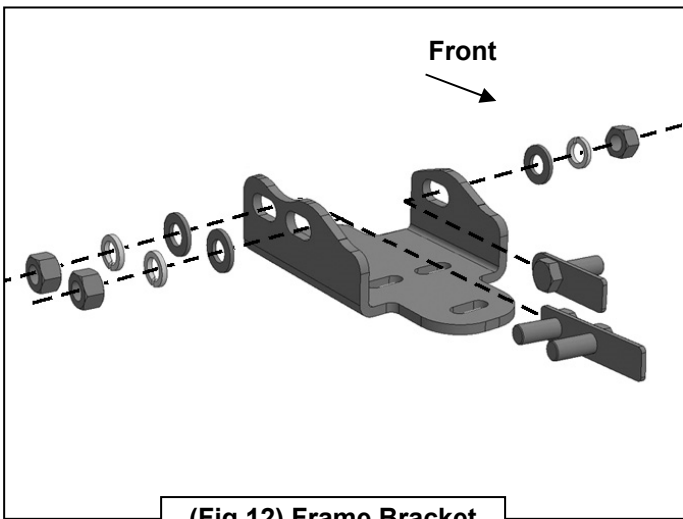

Fig 11



(Fig 12) Frame Bracket

Driver Side Mounting Bracket Installation Pictured

Mounting holes in end of frame for tow hook

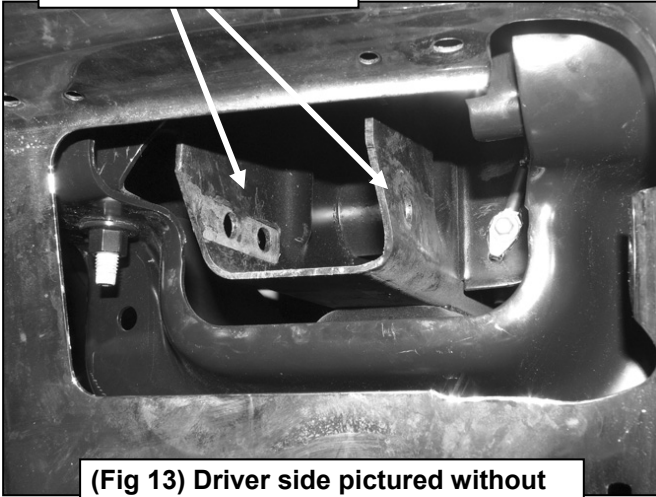

(Fig 13) Driver side pictured without plastic panel for instruction purposes



(Fig 14) Double Bolt Plate

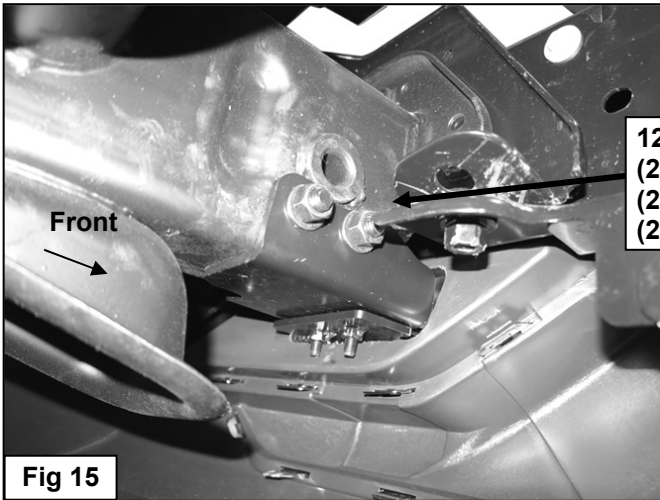

12mm Double Bolt Plate
(2) 12mm Flat Washers
(2) 12mm Lock Washers
(2) 12mm Hex Nuts

Fig 15

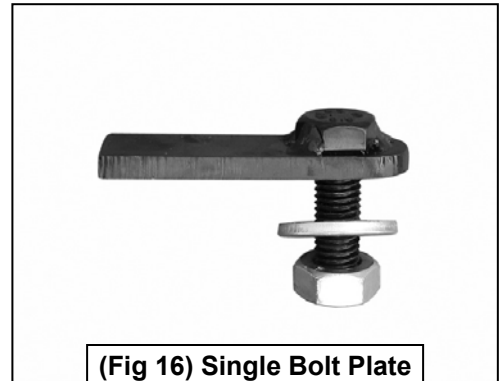

(Fig 16) Single Bolt Plate



12mm Bolt Plate
12mm Flat Washer
12mm Lock Washer
12mm Hex Nut

Fig 17

Driver Side Mounting Bracket Installation Pictured

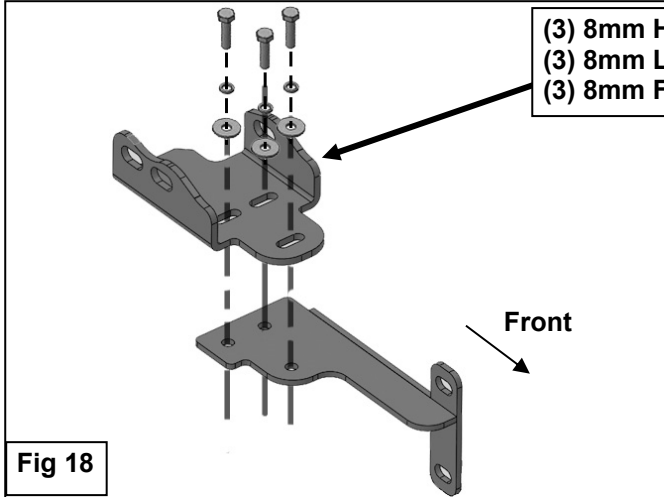

- (3) 8mm Hex Bolts
- (3) 8mm Lock Washers
- (3) 8mm Flat Washers

- (3) 8mm Hex Bolts
- (3) 8mm Lock Washers
- (3) 8mm Flat Washers

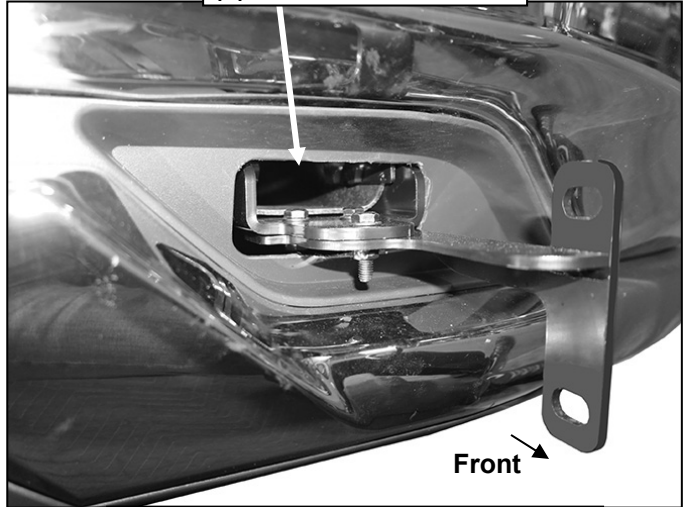

(Fig 19) Driver side Bracket Installed

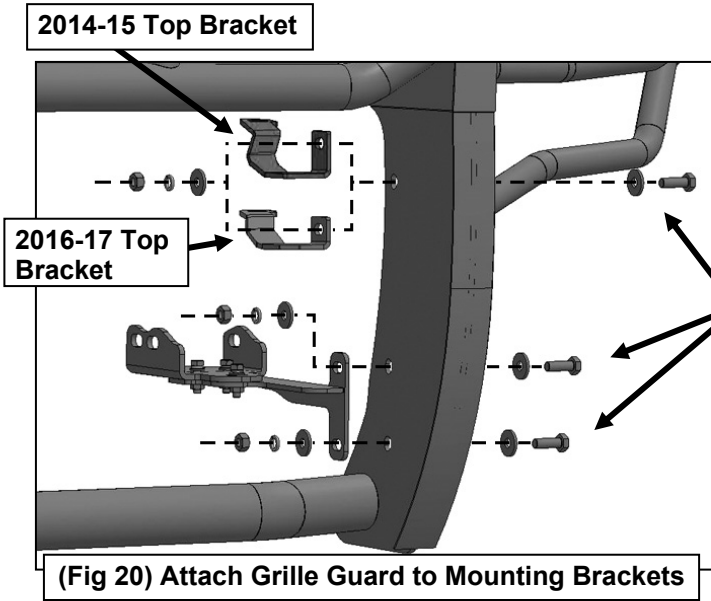

- (3) 10mm x 30mm Hex Bolts
- (6) 10mm Flat Washers
- (3) 10mm Lock Washers
- (3) 10mm Hex Nuts

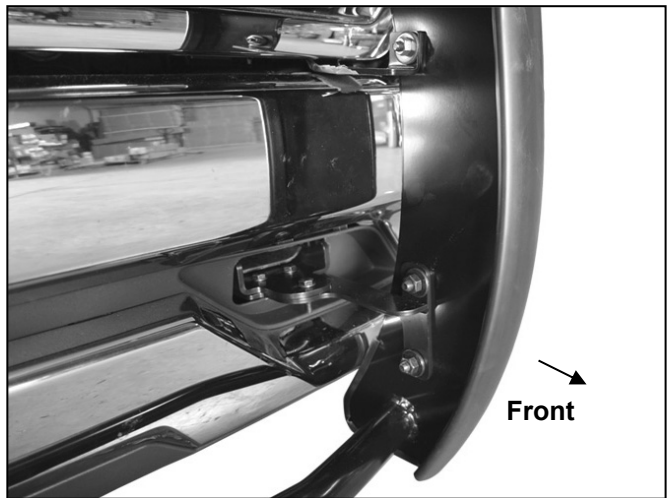

(Fig 21) Attach Grille Guard to Mounting Brackets