

(I-00300)

BD Engine Brake LIMITED WARRANTY STATEMENT

BD Engine Brake (the "Seller") warrants the following product(s):

All products manufactured or rebuilt by the Seller are to be free from defects in material or workmanship, which includes but is not limited to Turbochargers, Exhaust and Intake manifolds, Exhaust brakes, Intercoolers, Flex Plates, Transmissions, Torque Converters, Oil pans, Fuel pumps and systems, Electronic monitors and control systems. The Seller warrants to the original buyer of the product (the "Buyer") that it will repair or replace, free of charge, any product which has a defect in material or workmanship within the warranty period described below. Copy of original invoice is required to qualify for warranty.

A defect is defined as a condition within the product that would render the product inoperable under normal conditions of use and service. The Seller's responsibility under this Warranty is limited to the repair or replacement, at the Seller's option, of any warrantable product returned prepaid with complete service history and proof of purchase. A valid proof of purchase is a dated bill of sale or receipt.

A Return Material Authorization (RMA) number, obtained in advance from a customer service representative of the Seller and the dated bill of sale or receipt, must accompany any product returned by the Buyer for warranty determination. The Seller will be the final authority on the approval of all warranty claims hereunder. The issuance of a RMA number does not represent an approval of a warranty claim. BD reserves the right to return or replace Warranty Approved items freight Prepaid. While warranty denied or rejected, claims will be returned freight collect. Accepted warranty products, which have been replaced, will become the sole property of BD.

Until the Seller has approved a warranty claim, the Buyer will be responsible for all costs. Replacement parts and the labor costs incurred by the removal and replacement of the product while performing warranty work will be the responsibility of the Buyer. In no case does the obligation of the Seller exceed the original purchase price of the product as indicated on the original bill of sale or receipt. Under no circumstances will the Seller be liable for any travel time incurred in diagnosis for defects, or any other contingent expenses.

Only once the claim is approved, and depending on if the warrantable product is eligible, labor costs will be considered for the removal and replacement if an eligible part at an hourly rate of \$100.00 per hour. The end user may be responsible for the difference between the BD warranty labor rate and the authorized service dealer's labor rate. BD recommends the end user negotiate these conditions before the service is performed. As well the end user may be responsible for additional freight charges from FOB Abbotsford, BC / Washington.

To the extent permitted by law, the Buyer hereby waives all rights other than those expressly set out herein and acknowledges that this warranty sets out the Buyer's exclusive remedies with respect to products covered by it. This warranty shall not be extended, amended or varied except by written instrument signed by the Seller and the Buyer. If the buyer replaces the product from the Seller with another from another manufacturer, the Buyer-Seller warranty contract is void and the RMA Claim will be terminated. Any claim for remuneration will be rejected.

The Seller will administer warranty requests on products sold by the Seller and not manufactured by the Seller by forwarding claims made by a Buyer under the manufacturer's warranty to the manufacturer. The final disposition of such claims will be made by the manufacturer and ruled by the laws of British Columbia, Canada.

Customer assumes risk in purchasing product with in 30 days may return the product for exchange of other BD products or services only. No cash refunds are available.

The installation of BD aftermarket parts may void the OE warranty. BD is not responsible for OE warranties or how they are administered. Residents of the U.S.A. can reference the Magnuson-Moss warranty act that protects the consumer on the installation of aftermarket parts, please research this act to base your decisions accordingly.

In the case the warranty is denied, BD at its discretion, may offer to refurbish (where applicable) the product at discounted rate for the end user.

Please refer to Warranty time limitation per product.

NOT COVERED UNDER THIS WARRANTY

This warranty is limited to the original purchaser of the product and is not transferable to subsequent owners. Specifically excluded from this warranty are failures of products caused by misuse, misapplication, negligence of the Buyer, accidents, modification, abuse, improper storage, installation, repair or operation, use of unauthorized parts or other mistreatment of the Buyer or his agent. Any competitive use, sled pulling, drag racing will void warranty on product. A sheared or twisted shaft, broken planetary gear sets, burned clutches, broken drive hubs, sun gear damage, cracked housings are not covered. Damage caused from debris in oil contaminated coolers, improper fluids and filters or damage caused from fuel or air contamination, Biodiesel, low fluid levels are also not covered. This warranty does not cover deterioration of plating, paint or any other coating, linings or parts that are subject to normal wear and tear, such as light bulbs, fuses, bearing wear, seal wear, etc.

In the case of BD transmissions, a BD torque convertor must be installed at the time of installation of the transmission. Use of a 3rd party or OE convertor may invalidate the transmission warranty.

If product is not installed by a trained and authorized BD dealer, installation facility must prove it is properly tooled and has certified training to have installed or to carry out repair of product.

The Seller also disclaims any liability for incidental or consequential damages including but not limited to, repair labor, rental vehicles, hotel cost or any other inconvenience cost. To the extent permitted by law, this warranty is in lieu of all other warranties or guarantees, either expressed or implied, included the implied warranties of merchantability and fitness for a particular purpose and shall not extend to any Buyer or to any person other than the original purchaser residing within the boundaries of the continental U.S. or Canada. As well the seller is not responsible or obligated to update previously manufactured parts that are currently under the above warranty.

NOTE THAT THIS GUARANTEE WILL BE VOID IF THE USER BREACHES THE CONDITIONS IN THE SECTION LABELED "NOT COVERED UNDER THIS WARRANTY" AND IS ONLY APPLICABLE ON THE PRODUCTS THE SELLER MANUFACTURES.

DISCLAIMER OF LIABILITY

Other than as expressly set forth herein, the Seller, together with its distributors, jobbers and dealers shall in no way be responsible for the product's proper use and service. In no event shall the Seller be liable for any special, incidental, indirect or consequential damages of any kind or nature, whether or not the Buyer was advised of the possibility of damage, arising or resulting from the use or performance of the product, and the Buyer hereby waives any and all such claims.

The Buyer acknowledges that he/she/it is not relying on the Seller's skill or judgment to select or furnish goods suitable for any particular purpose and that the Seller has no liability that will extend beyond the scope of the limited warranty contained herein, and the Buyer hereby waives all remedies or liabilities, expressed or implied, arising by operation of law or otherwise, (including, without limitation, any obligations of the Seller with respect to fitness for any particular purpose; merchantability; and special, incidental, indirect or consequential damages) or whether or not occasioned by the Seller's negligence.

The Seller disclaims any warranty and expressly disclaims any liability for personal injury or damages related to the Buyer's use of the product. The Buyer acknowledges and agrees that the disclaimer of any liability for personal injury is a material term for this Agreement and the Buyer agrees to indemnify the Seller and hold the Seller harmless from any claim related to the product and its use or performance. Under no circumstances will the Seller be liable for any damages, liabilities, costs or expenses incurred as a result of by reason of the use, performance or sale of the product, including without limitation, any damages, liabilities, costs or expenses incurred by reason of the Buyer's negligence related to those uses of the product as a result of the removal of the speed limiter.

The Seller assumes no liability regarding the improper installation or misapplication of the product. It is the installer's responsibility to check for proper installation, and, if in doubt, contact the manufacturer.

Limited Warranty Details			
Product Name	Parts (Months/Miles) ¹	Labor (Months/Miles) ^{1,2}	Notes
Torque Converters	36/ 150,000	12/12,000	No Race abuse covered
Transmissions (TowMaster & TorqueMaster)	36/ 150,000	12/ 24,000	No Race abuse or broken shafts covered. Remote filter required for inspection with a cooler flow rate in GPM at Oil/Air transmission cooler outlet. Freight provision allowed.
Transmissions (RoadMaster)	24/ 100,000	12/ 24,000	
Rebuild/Repair Transmission	12/ 24,000	12/ 24,000	Defined as "Cost of Repair" or repaired units that fall outside of the retail warranty period.
Race Transmissions	12/ 24,000	Not Eligible	
Valve / Accumulators Bodies	12/ 24,000	12/ 24,000	
Transmission Pans	36/ 150,000	Not Eligible	
Flex Plates	36/ 150,000	Not Eligible	
Injectors (Mechanical) & Injection Pumps	12/ 24,000	12/ 24,000	VP44/P7100 Race Pumps 90 days parts/No labor coverage
Performance Injector Nozzles (Common Rail)	Not Eligible	Not Eligible	
Common Rail Injectors	24 Months	Not Eligible	Manufacturing and material defects are only covered. Cracks caused by high fuel pressure are not covered. High Return flow not covered after 12 months on Performance Injectors. For No Hassle Eligibility, see https://us.bddiesel.com/pages/extended-warranty
	24 Months + No Hassle	Not Eligible	
Performance Tuners and Chips	Manufacturer ³	Not Eligible	
BD Electronic Modules (TSB, VVB, etc)	24/ 48,000	Not Eligible	
Intake / Exhaust Manifolds	36/ 75,000	Not Eligible	
Exhaust Up pipes	12/24,000	Not Eligible	Surface rust not eligible.
Exhaust Kits	Manufacturer ³	Manufacturer ³	
Hoses / Clamps	12/ 24,000	Not Eligible	
BD Xtruded Transmission Cooler	12/ 24,000	Not Eligible	
Manual Transmission Clutches	Manufacturer ³	Manufacturer ³	
Short Shifters	12/ 24,000	Not Eligible	
Engine / Head Stud kits	Manufacturer ³	Manufacturer ³	
Positive Air Shutoff / Electronic Positive Air Shutoff	24/ 24,000	Not Eligible	
Exhaust Brakes	24/ 24,000	12/ 24,000	
Gauges and Mounts	Manufacturer ³	Manufacturer ³	
Screamer Turbos	24 Months	Not Eligible	24 Month warranty effective for sales after 11/01/2024
Performance/OEM Turbos	12 Months	Not Eligible	
Remanufactured ISX Turbos	90 Days	Not Eligible	See I-00437 for more details. For 1045880, see OEM Turbos.
Auxiliary Fuel Pumps	12/ 12,000	Not Eligible	
BD FICM	12 Months	Not Eligible	
Fuel Control Plate/Pin (VE & P7100)	24 Months	Not Eligible	
Distributed Product (Not Manufactured by BD)	Manufacturer ³	Manufacturer ³	
Replacement Components	12 Months	Not Eligible	
Transmission Rebuild/Build It Kits	12 Months	Not Eligible	Material Defects Only
Steering & Suspension Parts (Track Bar, Caster kit, Steering Stabilizer, Bars and links)	Limited Lifetime (12 months if not registered)	Not Eligible	Must register online within 30 days of purchase to be eligible. See website https://warranty.bddiesel.com/limited-lifetime/ for details. Excludes normal wear & tear (boots, bushings, joints, bearings) and improper use.
Venom/FlowMAX Fuel Lift Pump Kit	Limited Lifetime (12 months if not registered)	Not Eligible	Must register online within 30 days of purchase to be eligible. See website https://warranty.bddiesel.com/limited-lifetime/ for details. Excludes normal wear/service items (hose, filters) and improper use.

A Return Material Authorization (RMA) number, obtained in advance from a customer service representative of the Seller and the dated bill of sale or receipt, must accompany any product returned by the buyer for warranty determination.

¹ Warranty is based on whichever occurs first (Months or Mileage).

² Prior approvals must be given to qualify for labor reimbursement.

³ As per Manufacturer's warranty

Updated 10/21/2024

CHECKLIST FOR INSTALLING TURBOCHARGERS

1. Inspect the intake and exhaust systems leading to and from the turbocharger to ensure absence of foreign material, including burrs and loose lining fragments.
 - a. Be thorough – even small particles can cause severe rotor damage if inducted during high speed operation.
2. Use new and approved gaskets at the various air, oil and exhaust connections to the turbocharger
 - a. Avoid the use of sealing or jointing compounds at all flanged connections.
3. Use a high temperature anti-seize compound (such as Fel-Pro C5A) on all threaded fasteners connected to the turbocharger.
4. Limit the drain port tilt to 20° from bottom center in either direction.
 - a. Tilting in excess of this amount can create a low-idle leakage tendency at both the turbine and compressor seals.
5. Fill the oil inlet port to overflowing with clean engine oil before connecting the oil feed hose to the turbocharger.
6. If the clamp tabs or V-band are loosened for angular orientation of the compressor cover or turbine housing, be certain that the mating flanges are tightly reseated, and that the fasteners are retightened to the torque levels specified in the appropriate manual.
 - a. Complete the orientation of the cover and housing before making any rigid connections to the compressor inlet and outlet, or to the turbine outlet; this will make certain that all ducting aligns closely with the turbocharger; this will minimize the external stresses acting on the unit.
7. Before connecting the oil drain hose, crank the engine without firing until a steady stream of oil flows from the drain port.
8. Operate the engine at low idle for at least three minutes after completing the installation of any turbocharger. This will prevent oil starvation damage to the bearing system, and will tend to purge any residual contaminants from the bearing housing prior to the unit acceleration.
9. Always change the engine oil and filter when replacing a turbocharger.
10. Replace or clean the air filter.
11. In case of previous failure, inspect CAC for debris. Clean if necessary.

NOTE: Warranty will be denied if the turbocharger is installed on any application not previously approved by BD Diesel Performance.

General Factors Affecting Turbocharger Service Life

An analysis of turbochargers removed from service indicates that approximately 40% of the troubles are due to foreign material going through either the turbine or the compressor. An additional 40% are due to lubrication failures. The remaining 20% are of a miscellaneous nature.

Some of the foreign material damage is the result of pieces of burned or broken valves and combustion cups going through the exhaust system into the turbine. Other turbine damage is due to casting fins that may break out of the manifolds and ports. Occasionally improperly installed gaskets will permit pieces of gasket to overhang a port and break off into the exhaust system. Damage due to the nuts and washers that are dropped into the exhaust system is also altogether too frequent. Occasionally engine suffer from scuffed and broken pistons. Pieces of these pistons will damage turbine wheels.

Compressor wheel breakage also occurs due to foreign material although not as frequently as turbine wheel damage. Sometimes pieces of the air cleaner will break loose and go through the compressor. There have also been instances where hose connections fail and pieces of rubber or wire reinforcing from the hose gets into the compressor wheel.

Again, carelessness in allowing nuts, bolts and washers to get into the intake system sometimes causes compressor wheel failures.

Lubrication failure may be any one of a number of types. Undersized or plugged oil lines are quite common. It is essential to have an adequate supply of oil at full engine oil pressure for turbocharger bearings. The turbocharger runs at very high speeds and will very quickly overheat with even a momentary failure of oil supply.

The oil supplied to the turbocharger should first pass through a good filter of adequate size so that there is always full oil pressure at the turbocharger bearing. With an adequate supply of clean oil, turbocharger bearing will run for thousands of hours with no measurable wear.

Failure may occur due to extreme exhaust temperatures encountered in excessive altitude operation. Any engine that is operating close to its limits on exhaust temperatures at sea level will have excessive exhaust temperatures when operated at altitudes above 5000 feet.

Altitude operation will cause the turbocharger speed to increase and may cause failures due to over speeding as well as high temperatures unless the engine's fuel system is derated according to the manufacturer's recommendations.

Inlet restrictions due to plugged air cleaners, collapsing hose connections, or undersized air pipes have the effect of reducing the air supply to the engine and result in excessive exhaust temperatures. Both inlet restriction and the excessive altitude operation can cause turbine wheel failures due to excess temperatures.

With any turbocharger, it is possible to accumulate enough dirt in compressor housing and diffuser to reduce the airflow capacity and the efficiency of the compressor if air cleaning system is not maintained. Reduced air flow will cause the engine to run hotter and may result in burned valves and pistons which in turn will cause turbocharger failure.

Leaking gaskets or connections on either the intake or exhaust system of the engine will cause a reduction in the air supply to the engine and will result in high exhaust temperatures.

Sometimes air connections and exhaust connections are made in such a manner that thermal expansion of the exhaust manifold and other parts connected to the turbocharger will produce very high loads on the turbocharger. These high loads result in housing distortions that cause the compressor and turbine wheels to rub.

Excessively heavy piping that is supported only by the turbocharger may also cause distortion.

Turbocharger mounting that are not sufficiently rigid to prevent excessive vibrations in the turbocharger can also cause distortions and failures.

In conclusion it can be stated that every few turbocharger failures would occur if no foreign material were permitted to enter either the turbine or the compressor; if precautions were taken to prevent excessive exhaust temperatures, and if the turbocharger were always supplied with an adequate amount of clean oil.

IMPORTANT SAFEGUARDS

WARNING:

Misuse or modification of the turbocharger can result in serious injury and property damage. Basic safety precautions including the following should always be followed.

1. Read and comply with all instructions including “Checklist for Installing Turbochargers” before installing or using turbochargers. Read “General Factor Affecting Turbocharger Service Life”. (Contact BD Diesel Performance for any additional copies).
2. Install turbocharger only on an engine which has been approved for such application (check BD Diesel Performance Catalog). The turbocharger is a precision built product which has been matched and test for the intended application.
3. Do not modify or substitute any parts of turbocharger. Do not remove metal from any part of the turbocharger.
4. Disassembly and reassembly should done only in accordance with the appropriate set of the instructions provided with the turbocharger.
5. Do not modify or substitute any parts of the engine except in accordance with the engine owner’s manual. Do not modify engine fuel control system or restrict exhaust system or inlet excessively.
6. Do not operate at excessive altitudes (consult engine owner’s manual for altitude restrictions).
7. Be sure that oil supply and drain line are adequate (see “Check List for Installing Turbochargers”).
8. Always warm up engine for 2-5 minutes to allow oil to reach the turbocharger before operating under load.
9. Performance all maintenance specified by the engine manufacturer each time or at intervals maintenance is recommended by the engine manufacturer. Concurrently inspect turbocharger for any deficiencies described in the “General Factors Affecting Turbocharger Service Life”, and correct all observed or suspected deficiencies before operating the engine and/or turbocharger.
10. SAVE THIS LIST OF IMPORANT SAFEGUARDS, THE ENGINE OWNER’S MANUAL, “CHECKLIST FOR INSTALLING TURBOCHARGER”, AND “GENERAL FACTORS AFFECTING TURBOCHARGER SERVICE LIFE”.



**DOWNLOAD THE LATEST
INSTALL MANUALS AT
www.bddiesel.com**



BD Dodge CUMMINS Performance EXHAUST MANIFOLD







Installation Instructions

Application List		
2007.5-2018	6.7L – T4 Turbos	1045965-T4

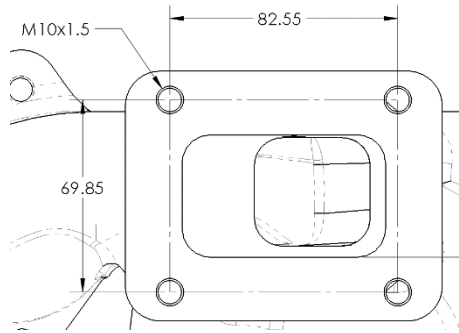
PLEASE READ ALL INSTRUCTIONS BEFORE INSTALLATION

KIT CONTENTS:

Please check to make sure that you have all the parts listed in this kit **before** you start the disassembly of your truck.

DODGE 2007-2018 6.7L (S400 Turbos) BD# 1045965-T4			
1405965-T4		 <p style="text-align: center;">T4 Flange Dimensions</p>	
			
Manifold			
Qty: 1			
1462431	1462430	1200208	1462441
			
<i>Stud M10-1.5 X 025</i>	<i>Stud M10-1.5 x 030</i>	<i>Plug 1/8" NPT</i>	<i>Nut M10-1.5</i>
Qty: 8	Qty: 2	Qty: 2	Qty: 10

Note the 1045965-T4 manifold will only fit custom installations with a T4 mounted turbocharger.

Please check to ensure you have received the correct manifold before installation. There will be a machine mark above the turbo mounting flange.

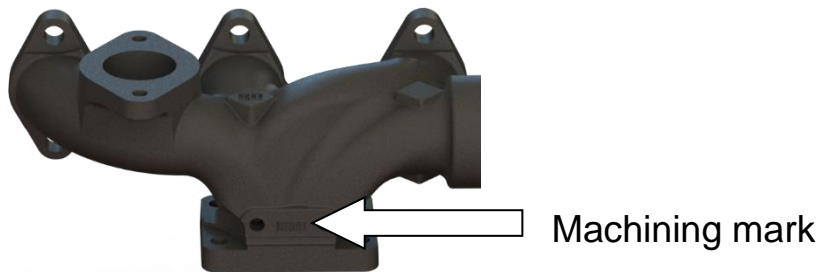

Options

<u>Description</u>	<u>Part #</u>
Dodge 6.7L Throttle Sensitivity Booster 2007-2014	BD # 1057932
Exhaust Manifold Gasket Kit 2008-2018 T4 Turbo	BD # 1045992-T4

Removal

1. Disconnect the battery negative cables. Drain the coolant. Raise and secure vehicle on hoist.



2. Next unplug the stepper (servo) motor connector and remove the two bolts (8mm) that hold the motor to the stepper motor bracket. Then release the cable to remove the motor from the vehicle.



3. Loosen the two nuts to remove the upper heat shield. (10mm)



4. Remove the air box and intake hose. Remove the air filter inlet hose from the turbo inlet.



5. Remove the top bolt from the lower heat shield (10mm) then the other two (8mm) bolts to release the lower heat shield.



6. Remove the three bolts for the stepper motor bracket (10 mm) socket and prop the bracket on the cooler.

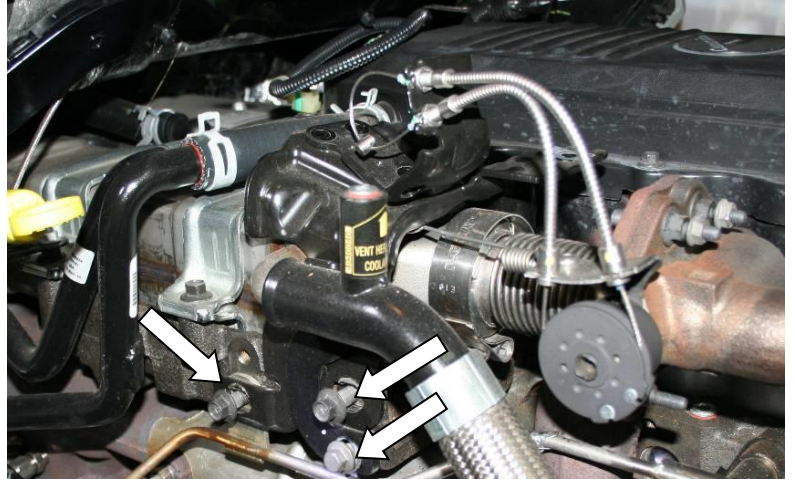

7. Loosen the clamp (11mm) that connects the EGR Flow Direction Valve to the cooler and slide the clamp towards the valve.

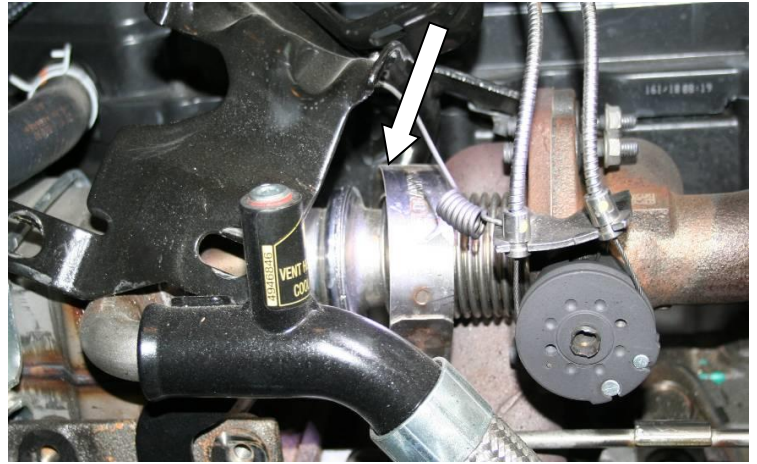

8. Using a (15mm) socket remove the outer nut for the exhaust flange of the flow valve at the manifold.

Using a socket with swivel or a wrench, remove the inner nut from the other side of the flange.



9. Remove the EGR flow direction valve from the vehicle.



10. Remove the bolt that holds the CCV hose to the cooler then disconnect the clamp at the valve cover to remove the hose assembly.



11. Remove the four bolts for the cooler and the nut that holds the transmission dip stick tube in place. Then nudge the tube out of the way to access the nut under the dip stick bracket.

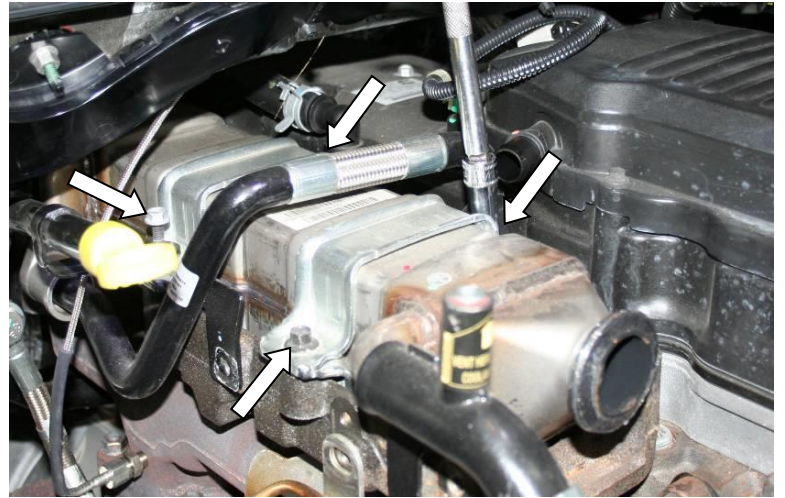

12. Remove the EGR coolant hose from the cylinder head to the cooler. (All bolts should be already removed) the hose is held in by orings. Remaining coolant will drip out.

optional Plug the cooler to avoid further drainage.



13. Remove the coolers two rear bolts that attach it to the exhaust system (15mm)

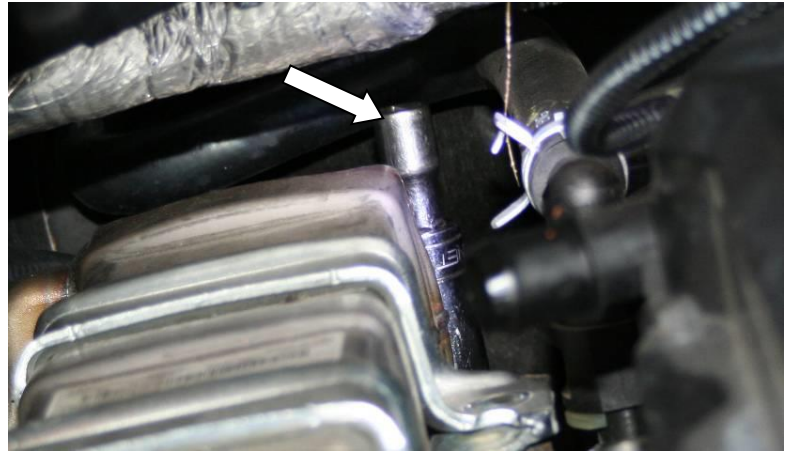

14. Prop the cooler above the studs and push towards the cab holding the other coolant hose to release the oring fitting to remove the cooler from the vehicle.



15. Remove the cooler mount bolts to the head (13mm socket) and remove the cooler mount from the vehicle.

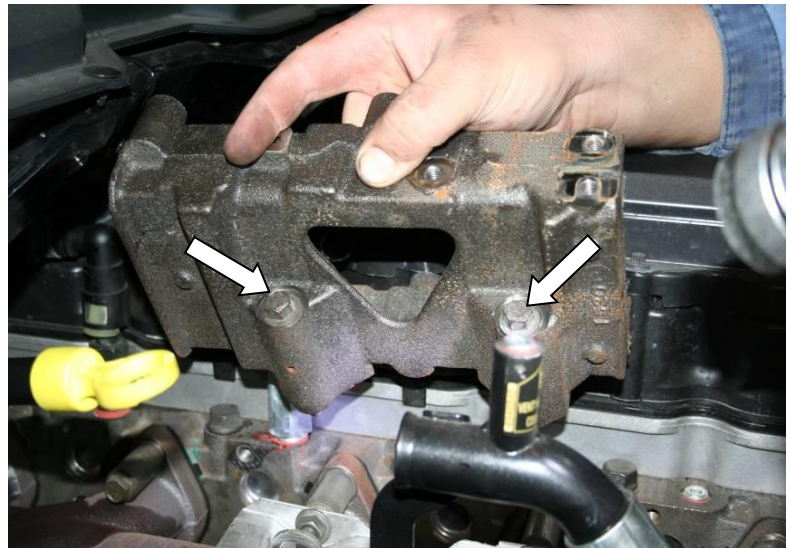

16. Remove the delta-P line bracket capscrew nuts and remove the delta-P line from the exhaust manifold and thermostat housing.

17. Remove the heat shield and noise panel (if equipped) from the exhaust manifold

18. Remove the coolant lines from the turbo, then remove the oil feed & oil drain lines. Disconnect the down pipe. Disconnect the CAC at the turbo outlet. Remove the four turbocharger mounting nuts to remove the turbo.

19. Remove the two (2) rear exhaust manifold cap screw lock plates.

20. Remove the Cab Heater tubing/bracket from the exhaust manifold stud.

21. Remove the exhaust manifold.

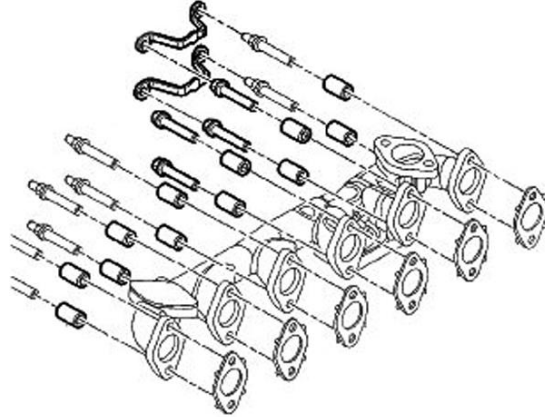

Installation

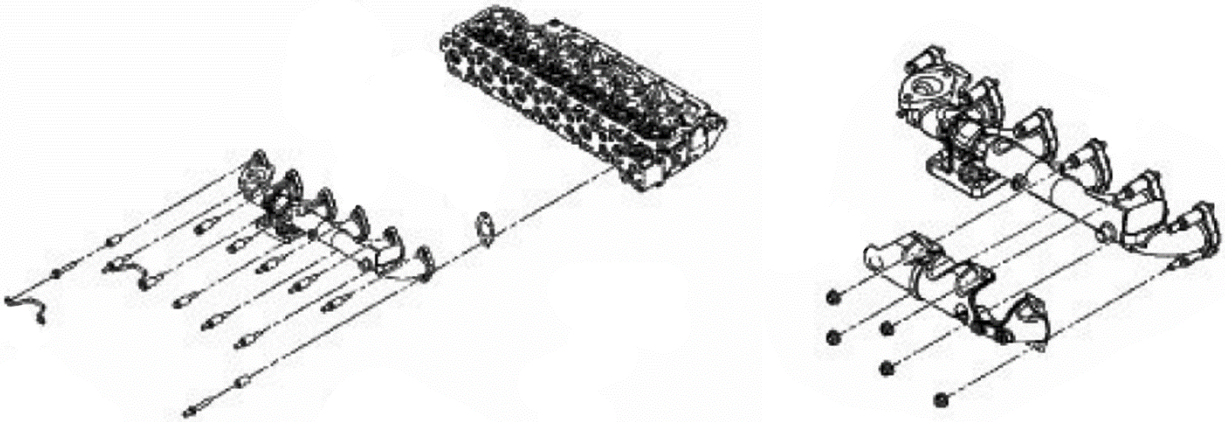

1. Clean the cylinder head exhaust port gasket surfaces.
2. Install supplied studs into BD manifold (see table below for locations)

T4 Manifold

(8x) 1462431- In all threaded holes

(2x) 1462430 – Lower Exhaust Ports #4 and #5

T4 shown below.

Note the **two** 30mm stud locations (arrows). All EGR ports and turbo mounts use a 25mm long stud

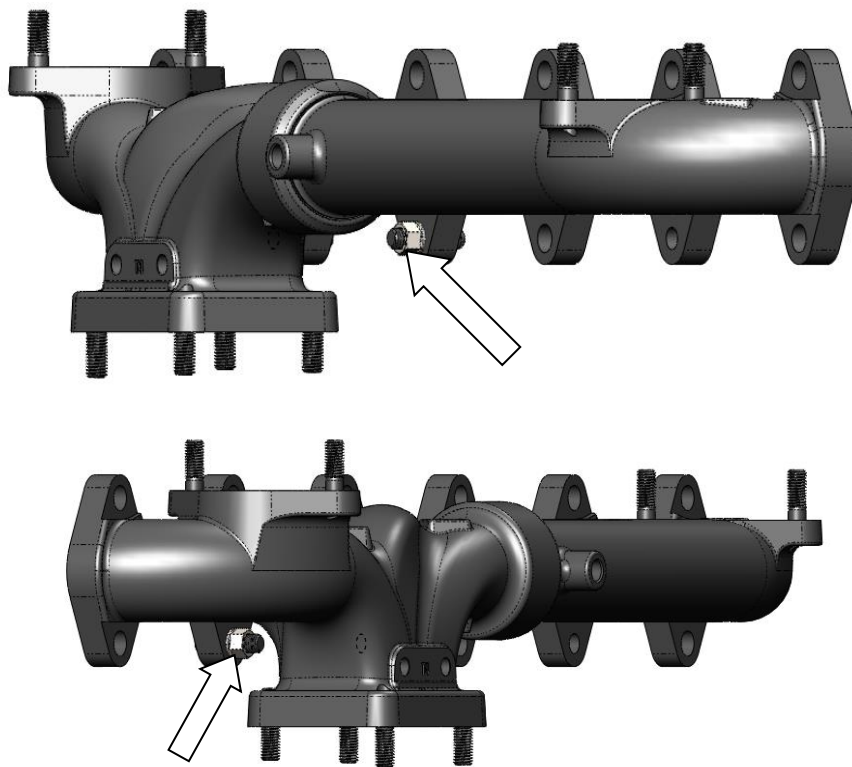

Arrows point to the locations of 30mm studs. All 25mm studs are installed in the EGR ports and T4 flange.

1. Install exhaust manifold with one factory bolts and the 1462430 studs to hold in place.
 - a. Using the supplied M10 x30mm studs, insert the stud at the lower mount of exhaust of cylinders 4 and 5. Lift the manifold into place as use these studs as the support. Don't forget to install the gaskets.
 - b. Then insert a factory bolt at the lower threaded mount of cylinder 2 with the gasket. Keep this bolt loose.
 - c. You will then need to thread the supplied M10 nuts on the M10 studs you installed earlier. It will be quite a challenge but can be done. You should be able to fit a boxed end wrench on the nut.

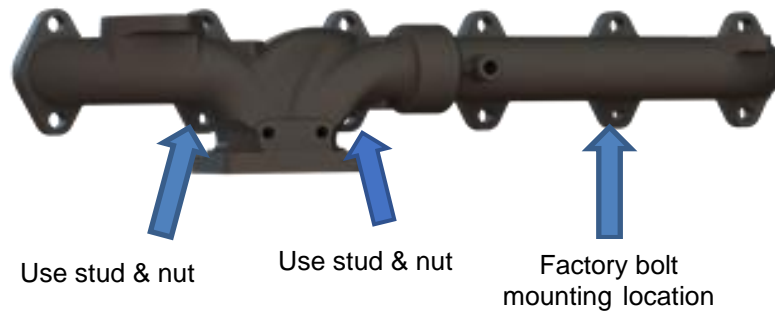

3. The five exhaust manifold cap screws with studs are used at the No. 1 and No. 2 cylinder locations for the heat shield mounting and one on the rear lower corner of the manifold for the cabin heater tube bracket.



4. Install remaining bolts and spacers with new gaskets.
5. Starting from the center and moving in a pattern outward, tighten the exhaust manifold bolts to 43 N·m (32 ft. lbs.)
6. Install the exhaust manifold capscrew lock plates.
7. Install the exhaust manifold heat shields/noise panels. Tighten the mounting nuts to 24 N·m (18 ft. lbs). **Note you will need to reform the heat shield.**

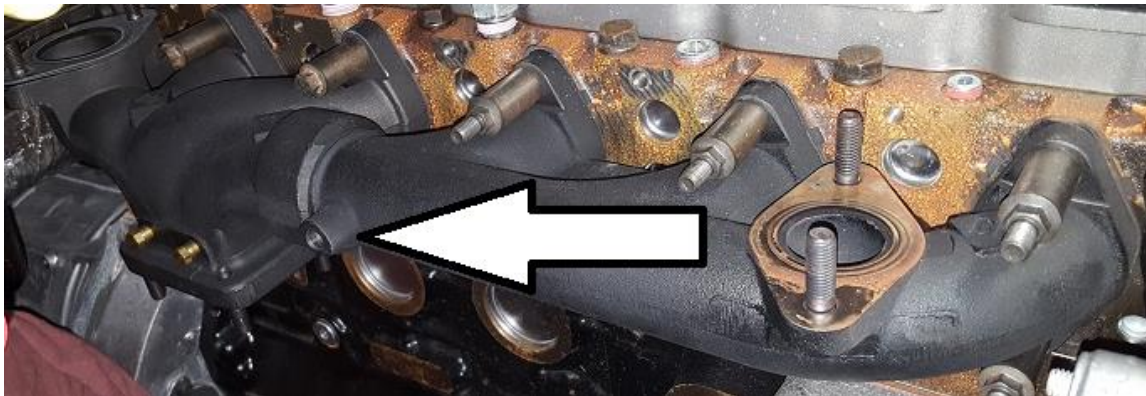

Please note the **M12 inverted flare port** is for the OEM back pressure sensor.

8. Install the turbocharger, and torque nuts to 43 N·m (32 ft. lbs.).

Important!: Tighten turbo flange in a crisscross pattern, repeating a second time to ensure the gasket is fully compressed and flange is tight. Improper torque can lead to flange leak and gasket failure.

NOTE: *If you are installing the T4 flange manifold, please refer to the install manual provided with your turbocharger for the completion of installation.*

9. Attach the mounting tabs and start the delta-P tube to exhaust manifold and thermostat capscrews.

10. Tighten the delta-P line bracket nut to 24 N·m (18 ft. lbs.).

11. Tighten the delta-P line bracket bolt to 10 N·m (89 in. lbs.).

12. Tighten the delta-P flare nuts to 10 N·m (89 in. lbs.).

13. Install the EGR cooler, using the existing hardware provided. Follow removal of EGR in reverse.

14. Install the air filter housing.

15. Re-fill the water system with coolant.

16. Connect the battery negative cables

17. Start the engine to check for leaks.

RE-TORQUE ALL BOLTS AFTER AT LEAST ONE HEAT CYCLE