

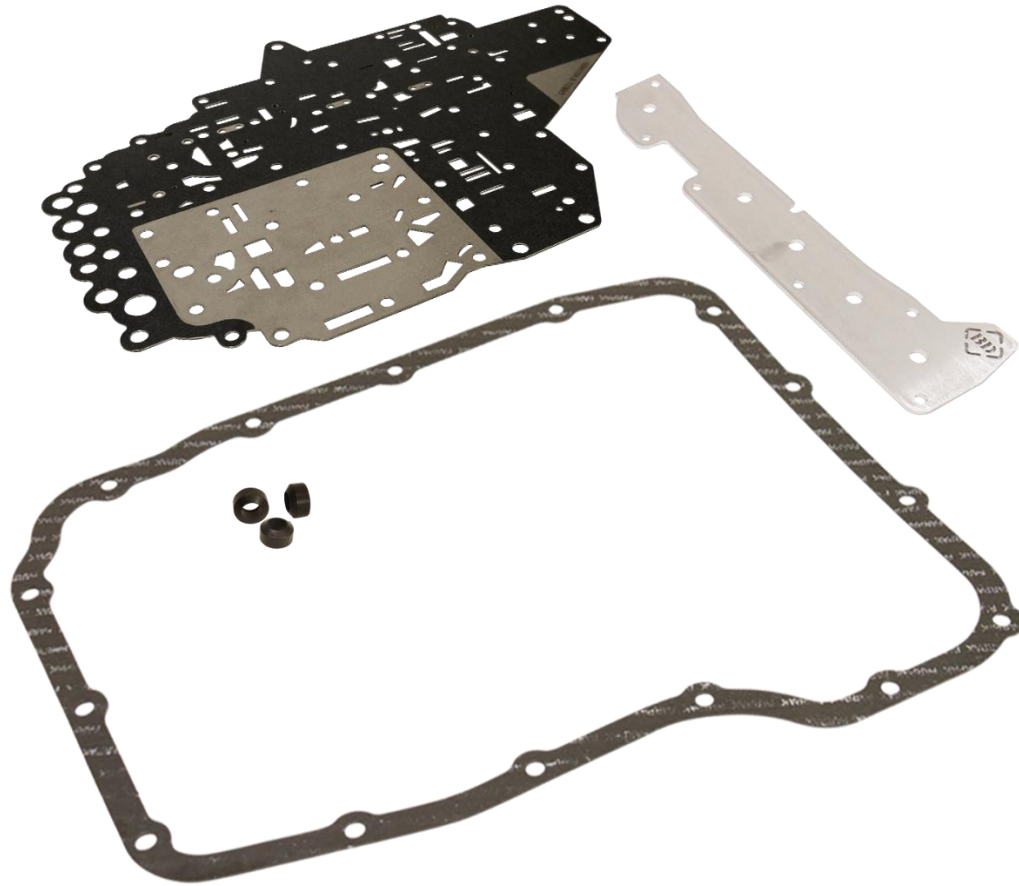

**DOWNLOAD THE LATEST  
INSTALL MANUALS AT  
[www.bddiesel.com](http://www.bddiesel.com)**



## **68RFE ProTect68 Plate Kit**

**1030373 | 2007-2018 68RFE Transmission**

**PLEASE READ ALL INSTRUCTIONS BEFORE INSTALLATION**

**DOES NOT FIT 2019+ (BLUE CONNECTOR) – SEE BD 1030375 (Coming Soon)**



***THIS PRODUCT MUST BE USED WITH AFTERMARKET TUNING***

This kit is for advanced users and tuners only. No warranty is offered other than workmanship of the product.

## Kit Contents

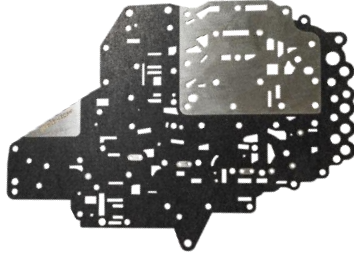
Please check to make sure that you have all the parts listed in this kit

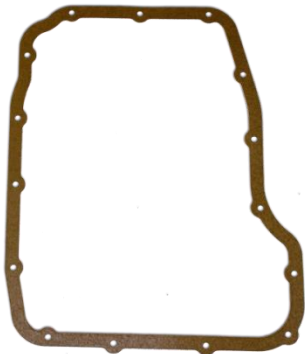
4799778	1600188
	
<p><b>Clutch Feed Seal</b> <b>Qty: 3</b></p>	<p><b>Gasketed; Separator Plate</b> <b>Qty: 1</b></p>

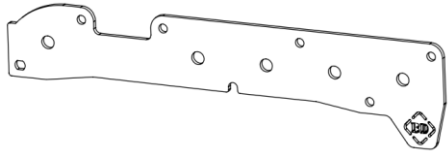
1601523	52118261	1600205
		
<p><b>Gasket</b> <b>Qty: 1</b></p>	<p><b>1/4" Check Ball</b> <b>Qty: 2</b></p>	<p><b>Accumulator Plate</b> <b>Qty: 1</b></p>

## Tools Required

- Drain Pan
- Transmission Funnel
- 8mm Socket
- T25 Torx Socket
- Torque Wrench (in/lbs)
- Drill
- 1/8" Drill Bit
- Brake Clean or Parts Cleaner
- Center Punch
- Scraper

## Upgrade Options

1030240	Torque Converter
1061525	6.7L HD Transmission Pan
1041220	6.7L Cummins Flex Plate
1061529	Adapter Tool – 68 RFE

# Transmission Pressure Tuning

Installing this gasket and plate kit will not by itself increase transmission line pressure. Instead it enables the transmission to be capable of generating higher pressure which must be commanded by either tuning the TCM or by means of an external module.

Here is an example of tuning parameters used to achieve the BD recommended 250psi maximum line pressure using HP Tuners (others similar).

Navigate to: **Trans > Auto Shift Properties > Shift Pressure**

Change **Max Pressure Lock** to **250 PSI**, **Max Pressure High** to **255 PSI**

In table **15582 "Maximum Line Pressure"**, change all but the last entry to **250**

In table **10098 "Maximum Line Pressure Per Gear"**, change all entries to **250**

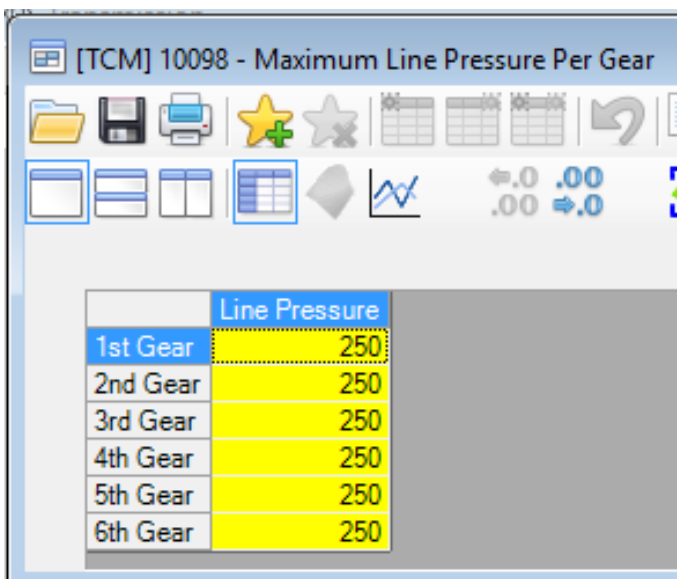
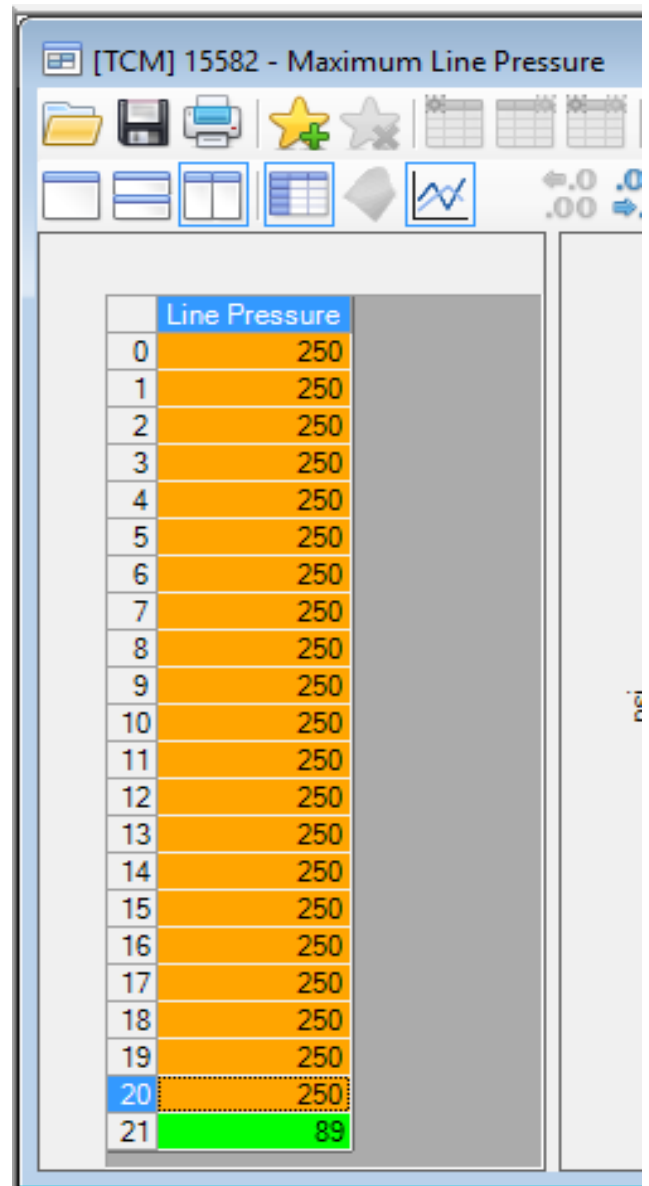
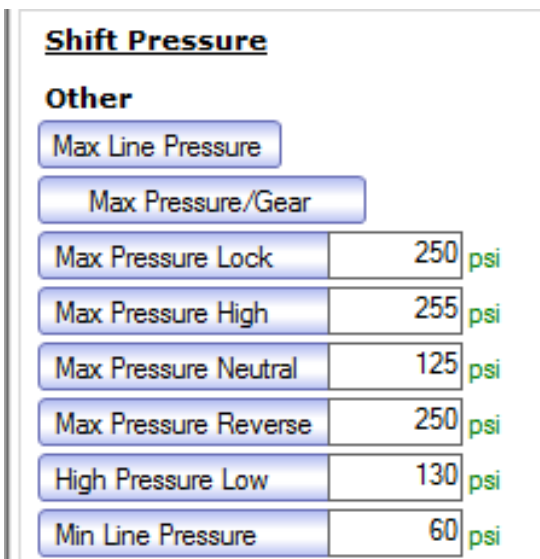

## Early Model / Late Model Transmission Identification



BD now supplies one kit for all 68RFE transmissions. It is no longer necessary to order a separate kit for early and late model transmissions. Pay attention to the instructions as they have changed.

To assist in the installation, you can go to YouTube and follow along the most critical install points.



<https://www.youtube.com/watch?v=fCoeMG2TFU>

## Valve Body Installation

1. Ensure all kit components are accounted for before installation (including the small check ball!).
2. Disconnect vehicle batteries and secure cables away from batteries.
3. Lift transmission dip stick approx. 6 inches to avoid interference later on.
4. Raise vehicle on vehicle lift. If using a jack, use safety stands and chock wheels.

5. Remove shifter cable from transmission for better access to the main electrical connector.



6. To remove connector, push red tab (1) downwards. Then, press the black tab (2) which will allow the white handle (3) to be rotated downwards, releasing the connector from the transmission.

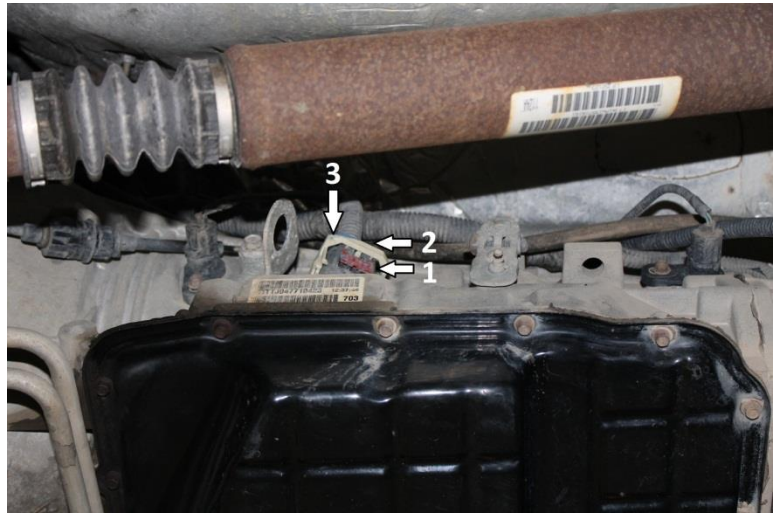

7. Position drain pan below the transmission.

8. Remove 14 of the 15 transmission pan bolts (8mm). Loosen the remaining bolt but leave in place to keep the pan from falling. The transmission cooler lines may need to be moved to access some of the bolts, gently pry them out of the way.



9. Tap pan with a mallet to break the silicone gasket seal. Allow fluid to drain. Remove last screw and drain remainder of fluid.



10. Remove transmission filter by removing the one T25 Torx screw.



11. Remove the six 8mm bolts securing the valve body to the transmission. Drain valve body of fluid. To remove valve body from transmission, wiggle it while pulling downwards to work the electrical connector through the case.



12. Place the valve body on a clean work surface.

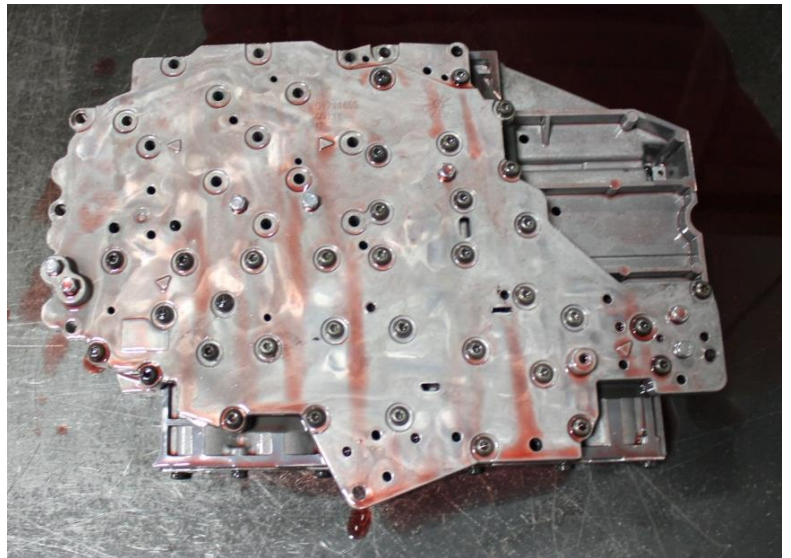

13. Remove fifteen T25 Torx screws securing the solenoid pack to the valve body, remove solenoid pack and place it to the side.

Note: All bolts are the same length.

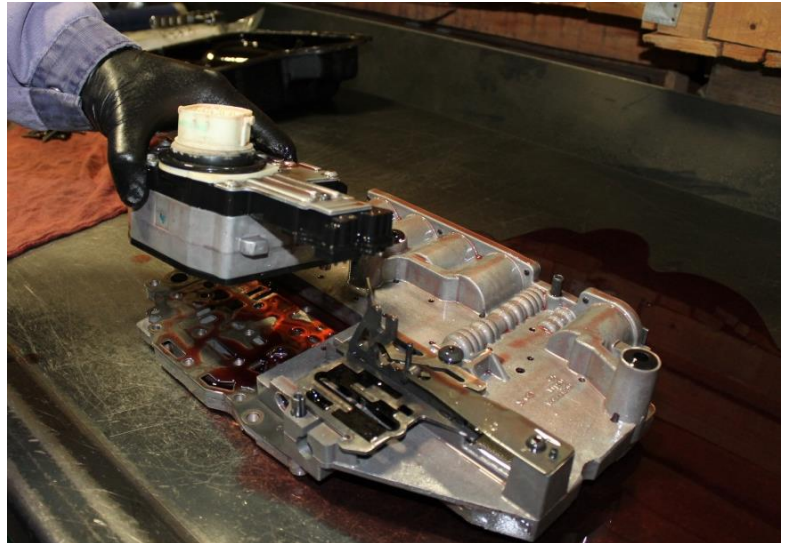

14. Remove remaining thirty-five T25 Torx screws securing the valve body halves.

Note: All bolts are the same length.

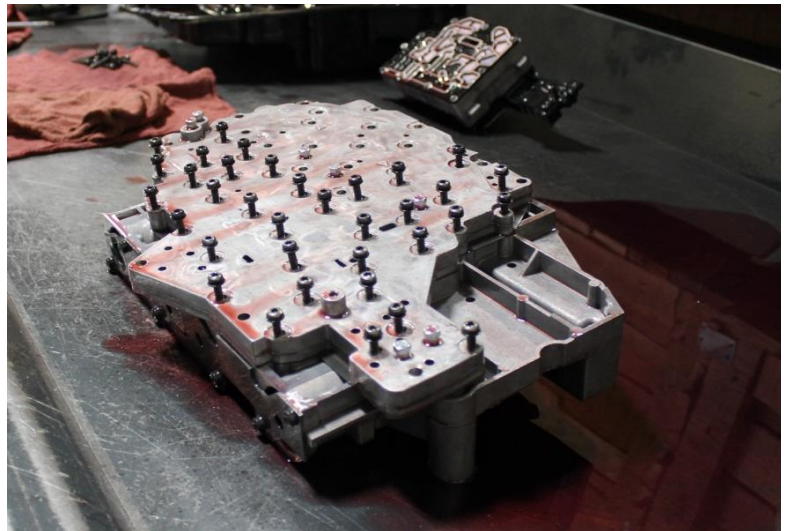

15. Carefully separate the two halves of the valve body. Separate as shown in pictures – *do not invert the larger (top) portion as it contains plastic check balls*. The two halves will have to be wiggled apart as the alignment dowels will be holding them together.

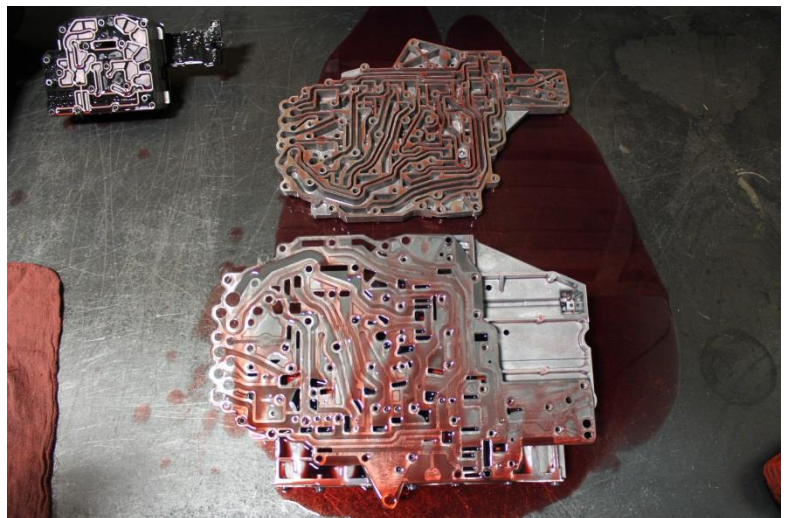

16. Remove old separator plate.

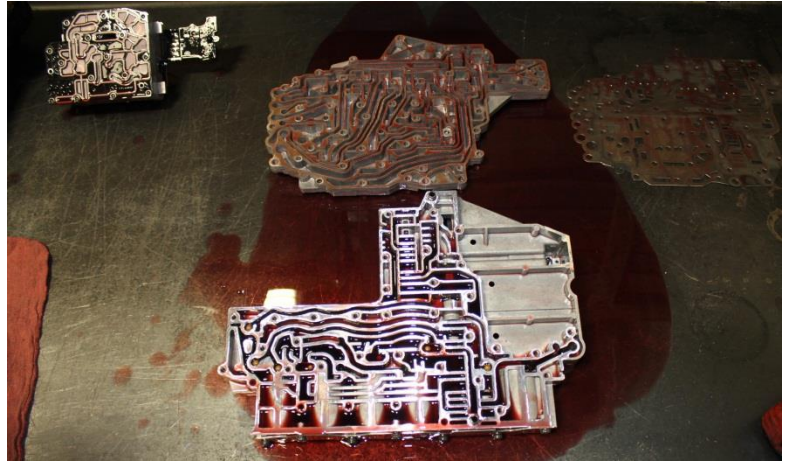

17. Thoroughly clean the bottom (smaller) half of the valve body. Locate the passage to be drilled.

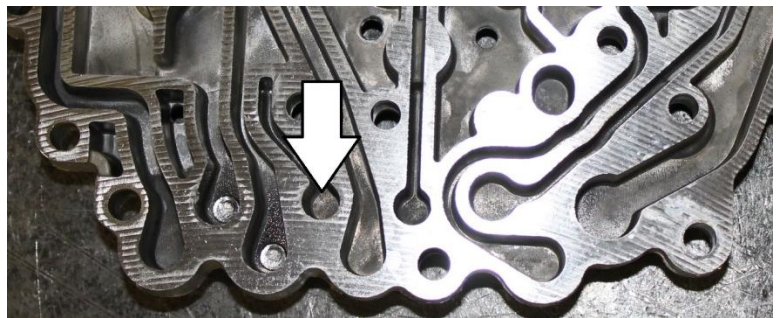
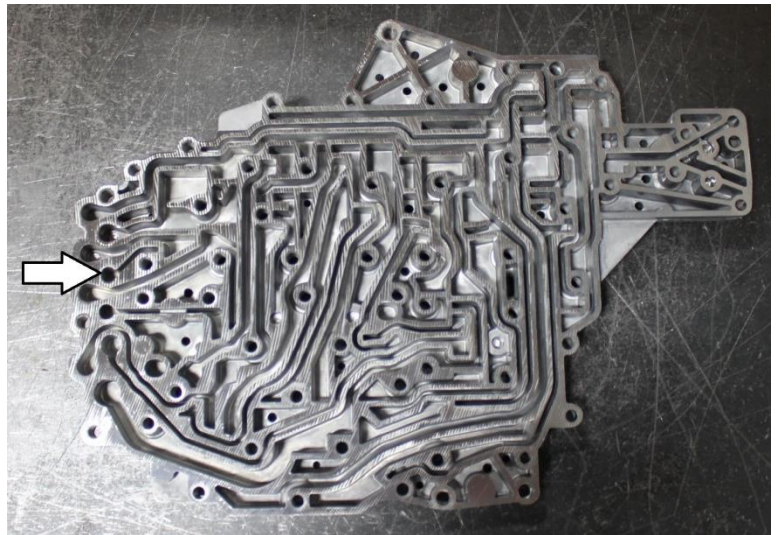

18. Punch center of hole using a center punch.

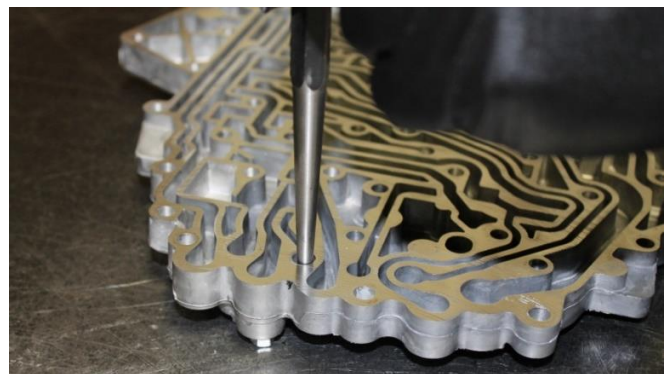

19. Drill hole with 1/8" drill bit.

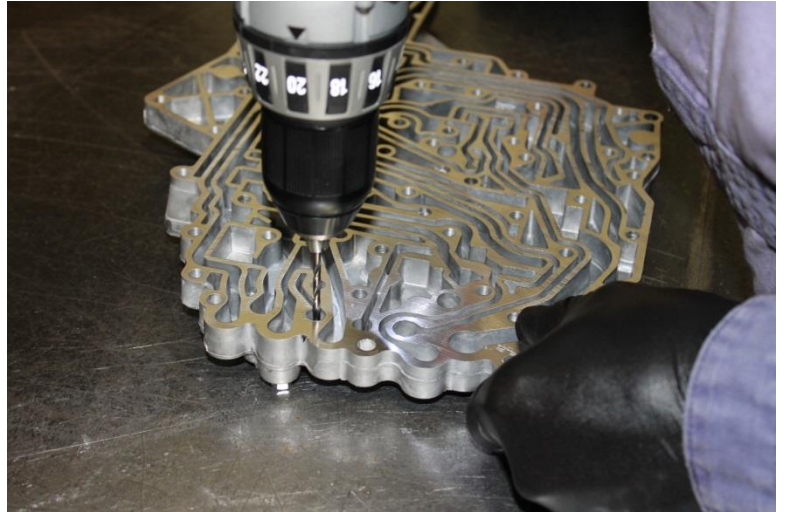

20. Thoroughly remove any burrs and clean all shavings from the valve body. It is imperative that no contaminants are left as they may cause transmission damage.



21. **IMPORTANT!** Ensure that all the check balls are in the locations shown.

If the electrical connector on the valve body is white make sure you have all seven check balls installed.

**Discard any extra check balls.**

*If this part has been contaminated in any way, it must be thoroughly cleaned before reassembly.*

**NOTE** White connector solenoid packs work on all 2007-2018 model years

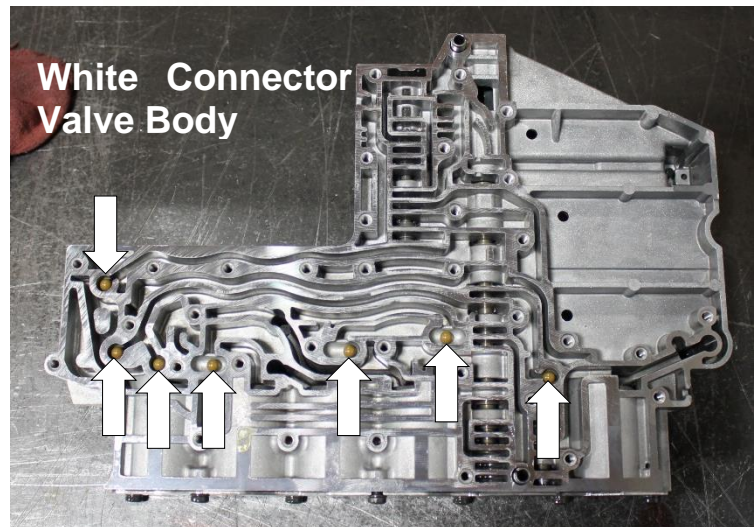
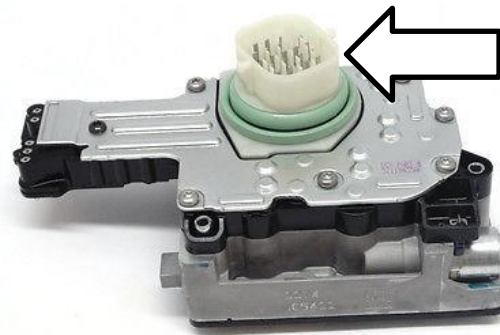

22. **IMPORTANT!** Ensure that all the check balls are in the locations shown.

If the electrical connector on the valve body is gray you will install six check balls rather than the five that were originally installed.

**Use the supplied extra check ball included in this kit for this. Refer to the diagram on the right.**

*If this part has been contaminated in any way, it must be thoroughly cleaned before reassembly.*

**NOTE** Gray connector solenoid packs **ONLY** work on 2010-2018

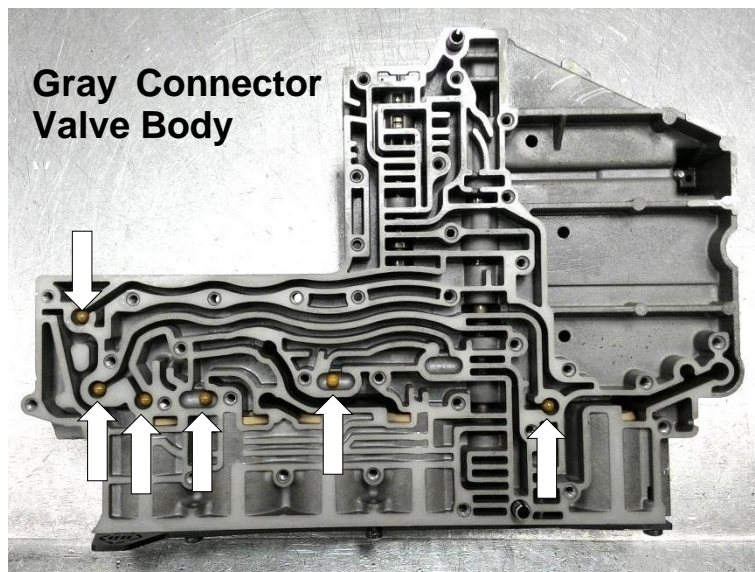
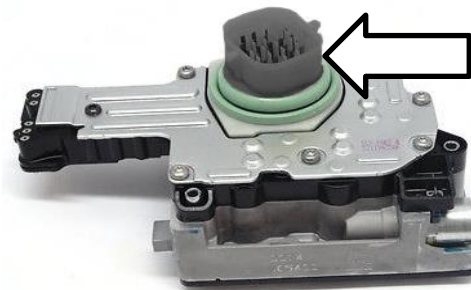

23. Install the BD bonded gasketed separator valve-body plate (1600188).

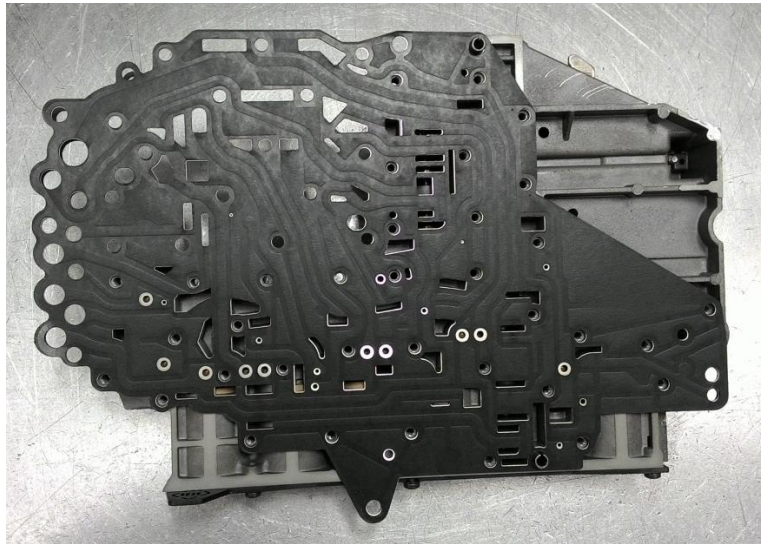

24. Re-install bottom (smaller) half of valve body. Ensure it fits flat on the separator plate/gasket. It may need to be worked downwards while rocking to be installed over the dowels. Install attaching screws so they are fully seated but do not tighten until the solenoid pack has been installed.

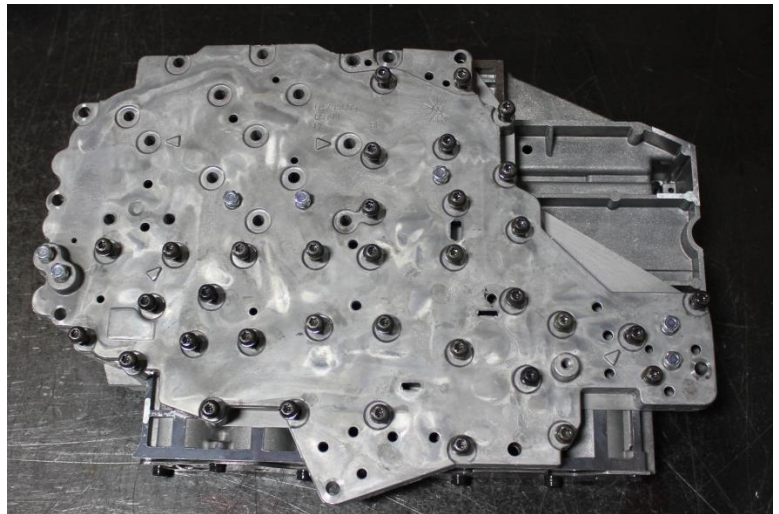

25. Re-install solenoid pack onto valve body. Be sure to properly align the pin on the solenoid pack with the slot on the valve body. Due to the alignment dowels, the valve body may need to be wiggled down into position. Install solenoid pack attaching screws. Install remaining Torx screws to fasten the solenoid pack to the valve body.

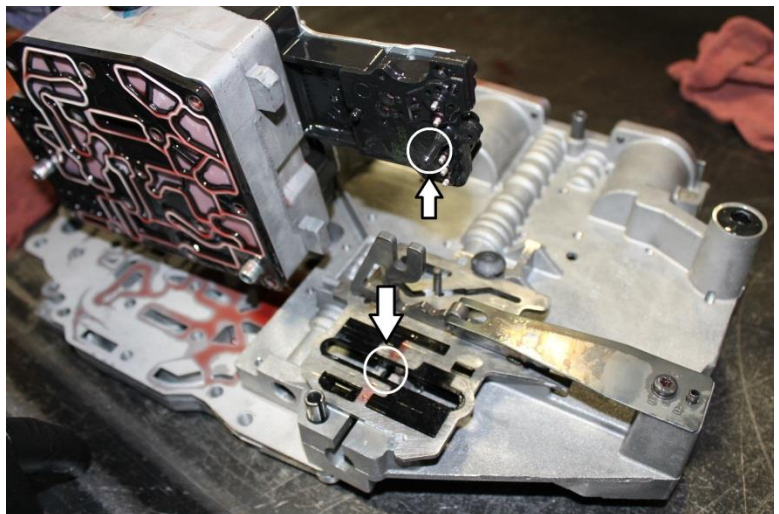

**IMPORTANT!** – On rare occasions, the solenoid pack gasket comes with a small nub on one side which will need to be removed using a file or blade before installation as the new plate blocks off the opening as it is not present on most applications.

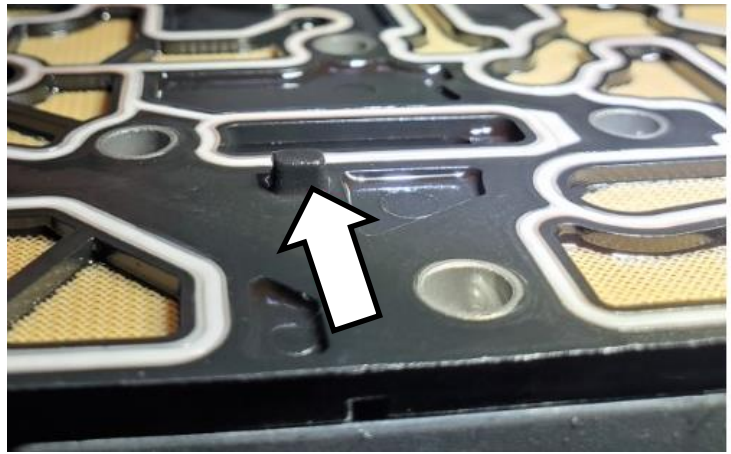

26. Remove the accumulator retainer plate and reinstall the supplied BD accumulator plate. Torque screws to 60 in-lb.

**IMPORTANT:** Over or under-torquing these fasteners can lead to blown out accumulator plates.

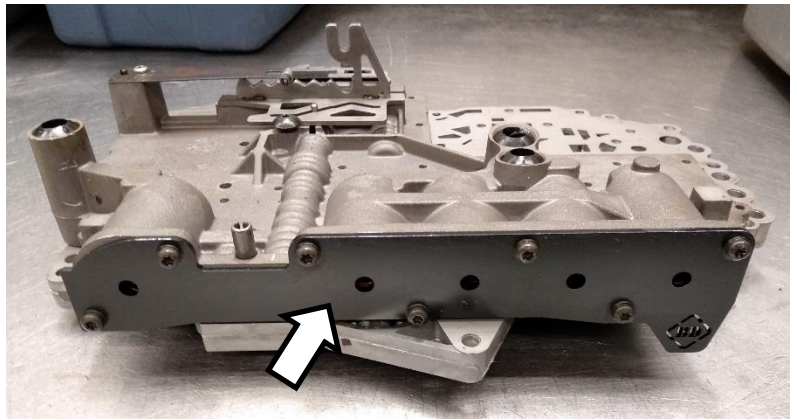

27. Torque all valve body Torx screws to 55 in-lbs, working from the center outwards. Carefully check that no screws were missed.

28. Inspect the three rubber seals on the top of the valve body, replace with supplied seals if they are nicked or otherwise damaged. Ensure the seal mating surface on the transmission is clean.

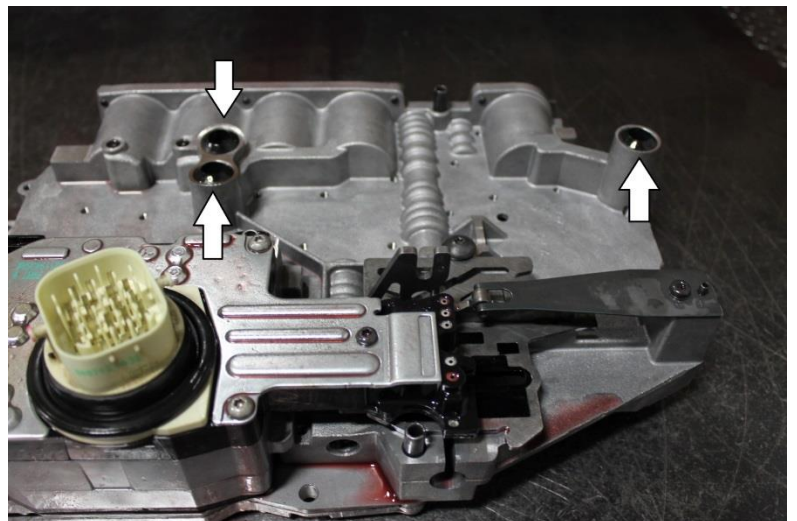

29. Wipe clean the bore on the transmission case around the electrical connector. Scrape all old silicone gasket material (if any) from the oil pan mating surfaces.

30. Check that the shift lever on the valve body lines up with the shift lever on the transmission and lift the valve body back into the transmission. Start the 8mm screws by hand, do not tighten yet. Work the shift lever on the outside of the transmission case by hand to ensure that the lever is making contact with the valve body correctly.

**IMPORTANT:** Use great care when reinstalling the valve body, the gasket that mates with the front of the case must line up correctly. Do not fold or pinch during installation.

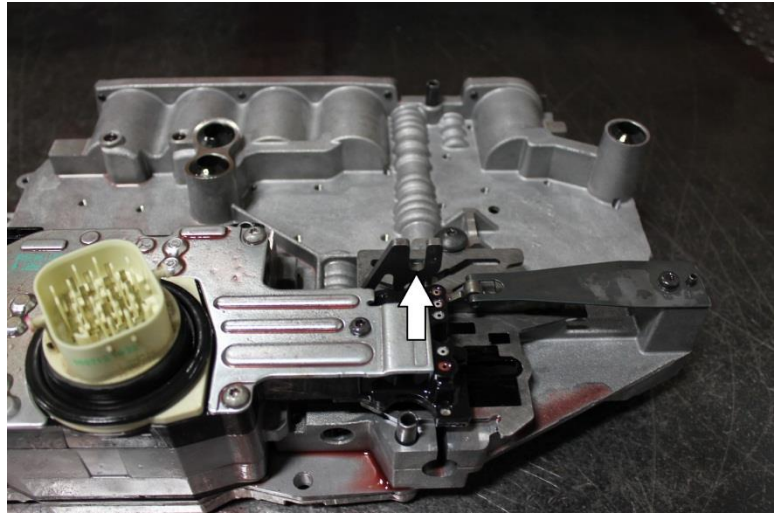

31. Torque the valve body attaching bolts to 105 in/lbs.



32. If desired, install new filter(s). Otherwise, reinstall the filter/pickup assembly. Torque to 50 in/lbs.



33. Place the supplied gasket on the transmission pan. Hold pan below transmission and install attaching screws. Torque the pan screws to 105 in/lbs.



34. Apply dielectric grease (supplied in pressure enhancer kit) to main electrical connector and reattach connector. Reattach shifter cable to shift lever.

35. Lower vehicle.

36. Reconnect vehicle batteries.

37. Fill transmission fluid until COLD line is met. Start and run vehicle. Move shifter through different gears twice to fill valve body. Check for leaks. Check fluid level again. Top up as required.

38. Road test. Run through upshifts several times at light throttle to ensure transmission is shifting correctly. Shifts will feel firmer with increased throttle.

39. Recheck fluid level.

40. Note. If you would like to verify the increases in line pressure, use adapter kit (BD 1061529) in conjunction with a 300psi gauge. Pressures at wide open throttle should be between 240 – 260 PSI with a mechanical gauge.

ADAPTER KIT BD# 1061529



Use this kit with a 300 psi gauge.

41. With this kit installed you will now have the capability to run 250psi of mainline pressure. Please ensure your transmission tuner knows that you have the BD Protect68 plate with gaskets installed.

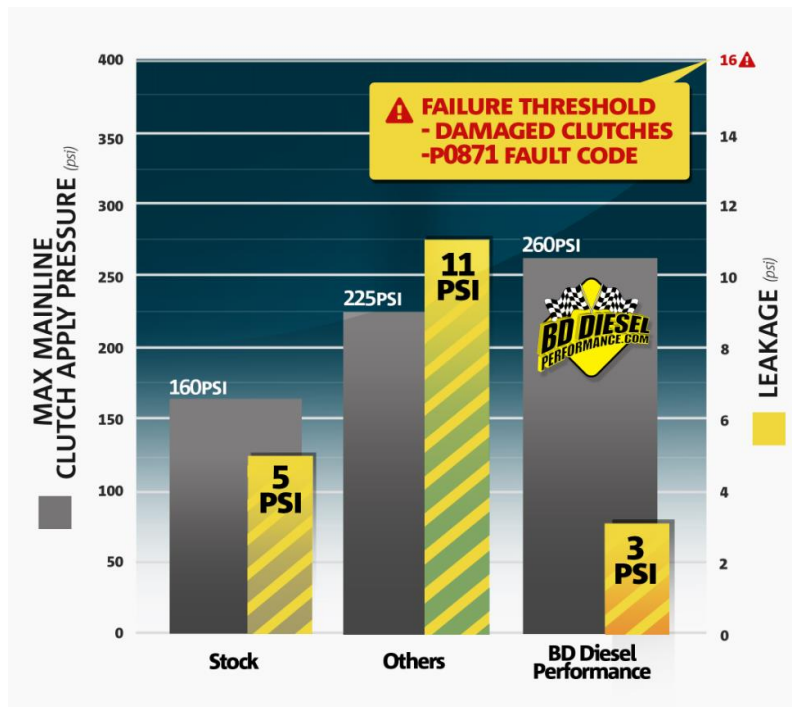

## **TECH Bulletin – Protect68 Kit P0871**

The protect68 kit is not designed to correct an already damaged transmission. Its purpose is to increase the reliability through increasing torque holding capacity of the transmission by increasing line pressure and eliminating cross leaks in the separator plate.

68RFE transmissions that run increased line pressure without a gasket (like the one included in this kit) may exhibit a P0871 due to cross leaks at the mating surface between the valve body halves. However, if this fault appears even after the installation of the gasket the problem may be a worn-out valve body.

By increasing main line pressure wear in the SSV bore may become more apparent. On high mileage transmissions the SSV valve bore may be worn, causing leakage into the overdrive hydraulic circuit. 2007.5-2009 trucks were highly susceptible to this damage. Model years after and including 2010 have an updated valve body that includes a hard-anodized coating which substantially increases lifespan. A hard-anodized valve body will be a dark gray color due to the coating.

The symptom would be a P0871 DTC (OD Pressure Switch Rationality fault). This DTC would normally be set in gears 1,2,3 at full throttle. If this is the case in which your vehicle has set this code before or after installing the protect68 your valve body has worn. The best solution is to purchase a new (revised) valve body from Chrysler with the hard-anodized coating. An alternative method is to ream the valve bore and install an oversized valve. This will resolve the problem for a while but it will eventually return.

If you would like to repair your valve body, please be aware that it is a difficult repair. Please take the valve body to a machine shop or a very experienced transmission repair facility that has the proper equipment.

You can purchase the repair kit from Sonnax.

**Sonnax 92835-32K** Oversized Solenoid Switch Valve & Plug Kit

**Sonnax F-92835-TL31** Tool Kit (reamer tool)

**Sonnax VB-FIX** Valve Body Reaming Fixture (not required but recommended)

[www.sonnax.com](http://www.sonnax.com)



**DOWNLOAD COLOUR  
INSTALL MANUALS AT  
[www.bddiesel.com](http://www.bddiesel.com)**

## **68RFE Rebuild Kits**

**Rebuild kits, Build-it parts, & Big Stack kit**

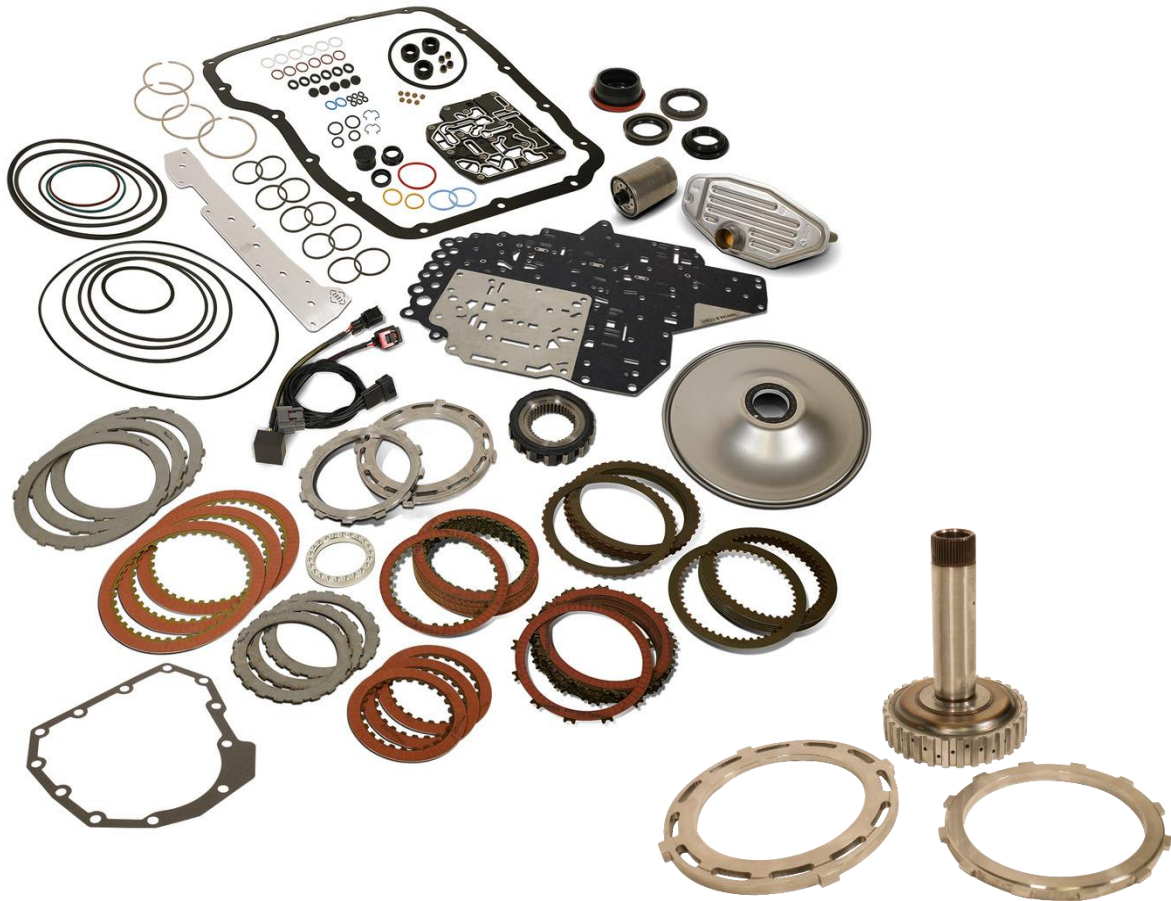

<b>Part #</b>	<b>Description</b>
<b>1062022</b>	<b>2007-2018 68RFE Rebuild Kit – Stage 2</b>
<b>1062023</b>	<b>2007-2018 68RFE Rebuild Kit – Stage 3</b>
<b>1062025</b>	<b>2007-2018 68RFE Rebuild Kit – Stage 4</b>
<b>1062027</b>	<b>2019+ 68RFE Rebuild Kit – Stage 3</b>
<b>1062035</b>	<b>Big Stack Overdrive Shaft &amp; Reaction Plates</b>
<b>1062036</b>	<b>BD Big Stack + Machined Sonnax Drum</b>

## ***Introduction***

BD offers a variety of proven 68RFE build-it kits to suite your truck needs. Additional parts/ kits are available should you or your transmission builder want to further increase the performance or durability of your 68RFE.

A transmission learn procedure must be performed should any of the following repairs be applied to the vehicle:

- Transmission Replacement
- Transmission Control Module Replacement (TCM)
- Solenoid Pack Replacement
- Clutch Plate and/or Seal Replacement
- Valve Body Replacement or Recondition
- Torque Converter Replacement
- Battery Replacement
- Power Upgrade or Flash Programmer Installation/ Updates

**IMPORTANT!** 2019+ valve bodies use an updated solenoid gasket, which must be carefully cleaned, inspected, and reused (Figure 1). If it must be replaced, it is only available with a new solenoid pack.

The 2019+ kit also contains a different Protect 68 Plate Kit, and the check ball that was required in the prior years is no longer required, and is not included.

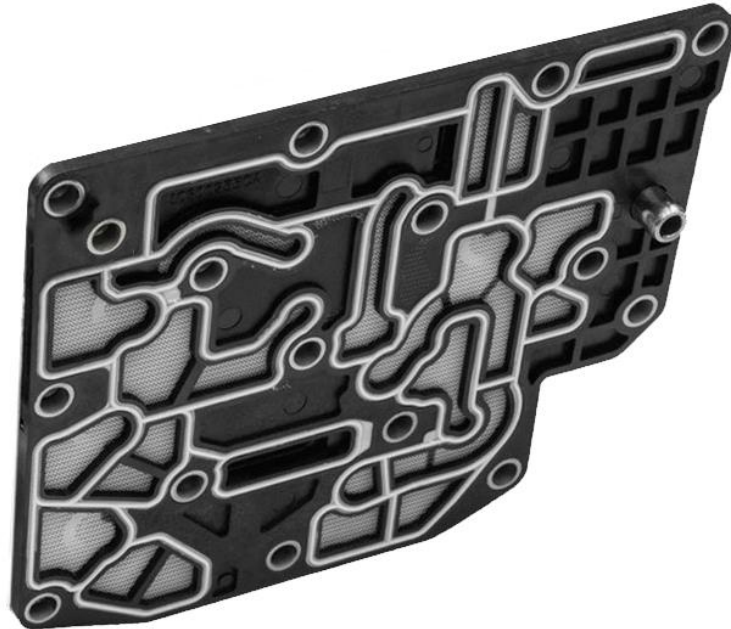

Figure 1. 2019+ Solenoid Gasket

## ***Upgrades/ Individual parts***

The below items are available separately and can be purchased individually to customize your transmission build.

<b>BD Part Number</b>	<b>Description</b>
1064043	Filter Kit; Service 68RFE
1030374	Adapter;68rfe Filter Threaded
1030362	68RFE Protect 68 Gasket & Pressure Control
1061525	BD Heavy Duty Transmission Pan
1041221	BD 68RFE Flexplate
1060603	68rfe One Way Clutch/ Sprag
1600189	Billet Input Shaft
1062034	Billet OD Selector Plates (14 frictions)
1062035	“Big Stack” Overdrive shaft + Selector Plates (16 OD frictions)
1062036	“Big Stack” Overdrive shaft + Selector Plates + Large Area OD Drum

## 2007-2018 Build-it Kit Contents

BD Part Number	Description	1062022 Stage 2	1062023 Stage 3	1062025 Stage 4
K29900L(A)	Gasket and Seal Kit	1	1	1
R600888	2C Friction	3	3	3
29303	2C Steel	3	3	3
B29308L	OD Housing Friction	15	15	15
B29309L	OD Housing Steel	15	15	15
29310	4C Friction	3	3	3
29311	4C Steel	3	3	3
29321L	Rev Friction	7	7	7
29322L	Rev Steel	7	7	7
29601	Filter, Pan	1	1	1
29609	Filter; Spin-on	1	1	1
1600180	4C Spring Retaining Ring	1	1	1
1600163	Selector Plate; OD/Rev (14 OD frictions)	1	1	1
1600162	Selector Plate; UD/ OD (14 OD Frictions)	1	1	1
1030373(B)	Protect 68 Plate kit	1	1	1
1600197	Gasket; 68RFE Ext Housing	1	1	1
52119645AA	Cover; Oil Pump	0	1	1
1060603	Sprag; One way	0	1	1
1030369	Pressure Module	0	0	1

**(A)**K29900L Gasket and seal kit:

- Gasket; 68rfe Pan (1601523)
- Gasket; 68rfe Solenoid Pack
- Seal; Solenoid Pack Connector
- Seal; 4wd Output Shaft
- Seal; 2wd Output Shaft
- Seal; Input Shaft
- Gasket Kit; Oil Cooler
- Seal Kit; 2-4C
- Seal Kit; Input drum
- O-ring; Pump Cover
- Sealing Kit; Piston rings
- Seal Kit; Solenoid pack
- Seal Kit; Internal valve body and orifices
- Seal Kit; External
- Check Balls; 1/4" - Qty 7

**(B)**1030373 Protect 68 Plate Kit:

- Bonded Valvebody Gasket Plate
- Heavy Duty Accumulator Plate
- Transmission Pan Gasket
- Clutch Feed Seals
- Check Ball

## 2019+ Build-it Kit Contents

BD Part Number	Description	1062027 Stage 3
K29901L (A)	Gasket and Seal Kit (2019+)	1
R600888	2C Friction	3
29303	2C Steel	3
B29308L	OD Housing Friction	15
B29309L	OD Housing Steel	15
29310	4C Friction	3
29311	4C Steel	3
29321L	Rev Friction	7
29322L	Rev Steel	7
29601	Filter, Pan	1
29609	Filter; Spin-on	1
1600180	4C Spring Retaining Ring	1
1600163	Selector Plate; OD/Rev (14 OD frictions)	1
1600162	Selector Plate; UD/ OD (14 OD Frictions)	1
1030375 (B)	Protect 68 Plate kit	1
1600197	Gasket; 68RFE Ext Housing	1
52119645AA	Cover; Oil Pump	1
1060603	Sprag; One way	1
1030369	Pressure Module	0

**(A)**K29901L Gasket and seal kit:

- Gasket; 68rfe Pan (1601523)
- Seal; Solenoid Pack Connector
- Seal; 4wd Output Shaft
- Seal; 2wd Output Shaft
- Seal; Input Shaft
- Gasket Kit; Oil Cooler
- Seal Kit; 2-4C
- Seal Kit; Input drum
- O-ring; Pump Cover
- Sealing Kit; Piston rings
- Seal Kit; Solenoid pack
- Seal Kit; Internal valve body and orifices
- Seal Kit; External
- Check Balls; 1/4" - Qty 7

**(B)**1030375 Protect 68 Plate Kit:

- Bonded Valvebody Gasket Plate
- Heavy Duty Accumulator Plate
- Transmission Pan Gasket
- Clutch Feed Seals

**Installation – 68RFE Rebuild Kit**

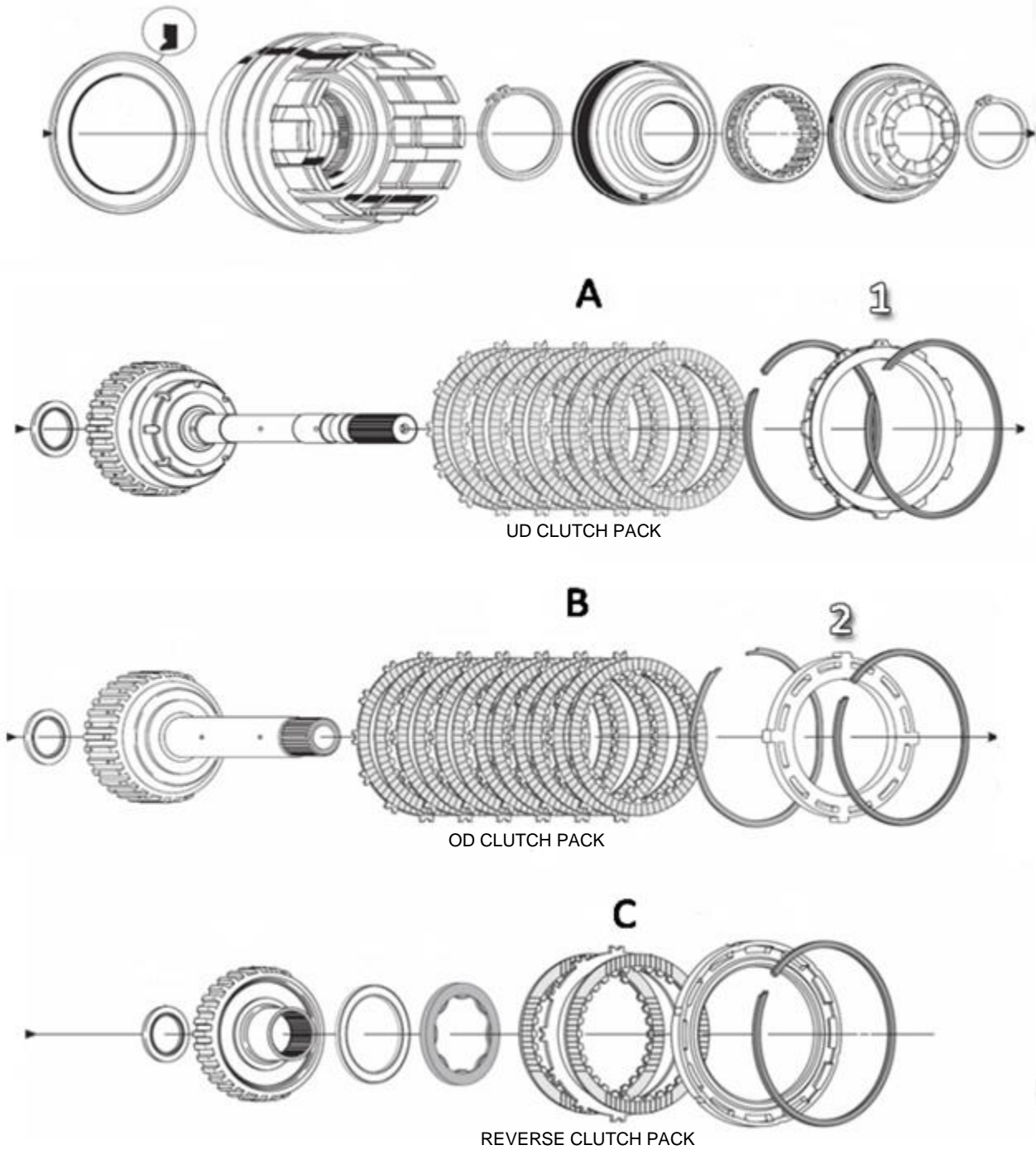

- A – Underdrive Clutch – Use 6+6 of B29308L & B29309L (OEM uses 5+5)
- B – Overdrive Clutch – Use 7+7 B29308L & B29309L (OEM uses 6+6)
- C – Reverse – Use 2+2 of B29308L & B29309L (OEM uses 2+1)
- 1 – UD/OD Pressure Plate #1600162 (can only be installed one way)
- 2 – Rev/OD Pressure Plate #1600163 (can only be installed one way)

**68RFE Rebuild Kit – Clutch Assembly (Standard BD Build)**

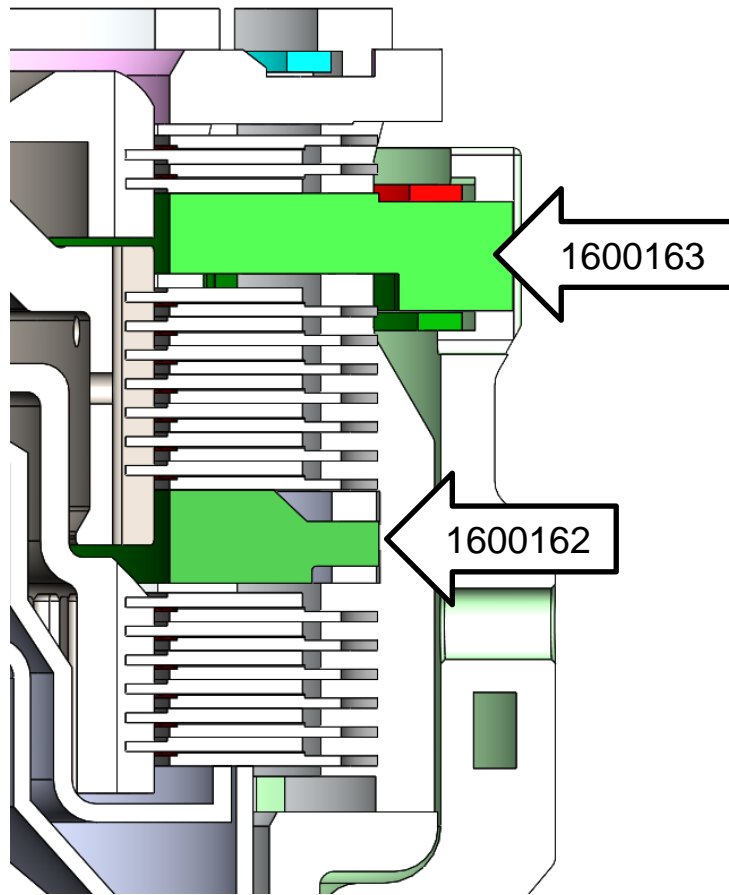

Note 1: The tapered section of the UD/OD pressure plate (1600162) must be facing upward.

Note 2: OEM snap rings MUST be used

Note 3: All UD and OD clutch plates must face upwards

Note 4: Single sided reverse clutches may be oriented either direction

<b>68RFE Clutch Clearance</b>	
Soak all clutches in ATF for 30 minutes before installing and measuring clutch pack clearance	
Underdrive	.040 - .068"
Overdrive*	.030 - .063" *
Reverse	.023 - .058"
L/R	.046 - .082"
4C	.030 - .055"
2C	.038 - .066"

**\* 16 friction Big Stack Overdrive kits require different clutch clearances  
See Page 9\***

## **1st Gear Sprag**

Please be sure to follow the instructions provided with the sprag to ensure correct functionality.

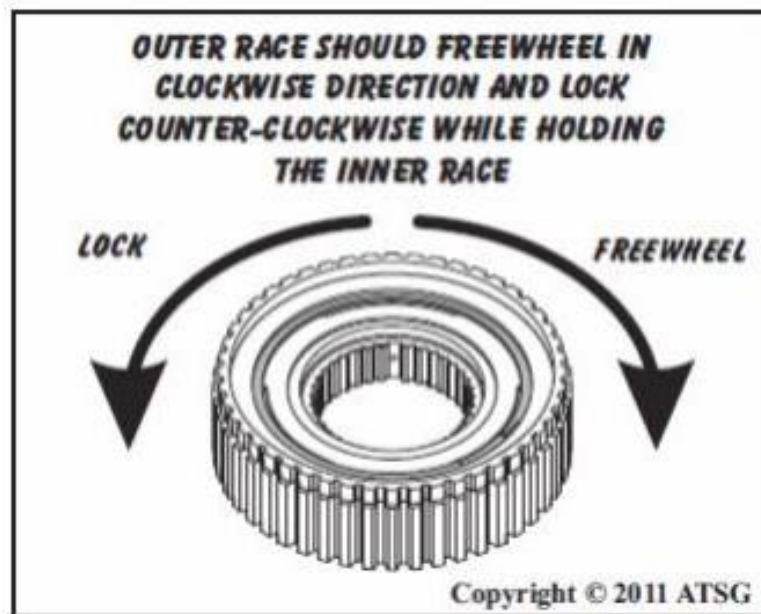

## **Billet 4C spring retainer**

The billet 4C spring retainer (1600180) must be oriented as shown below.

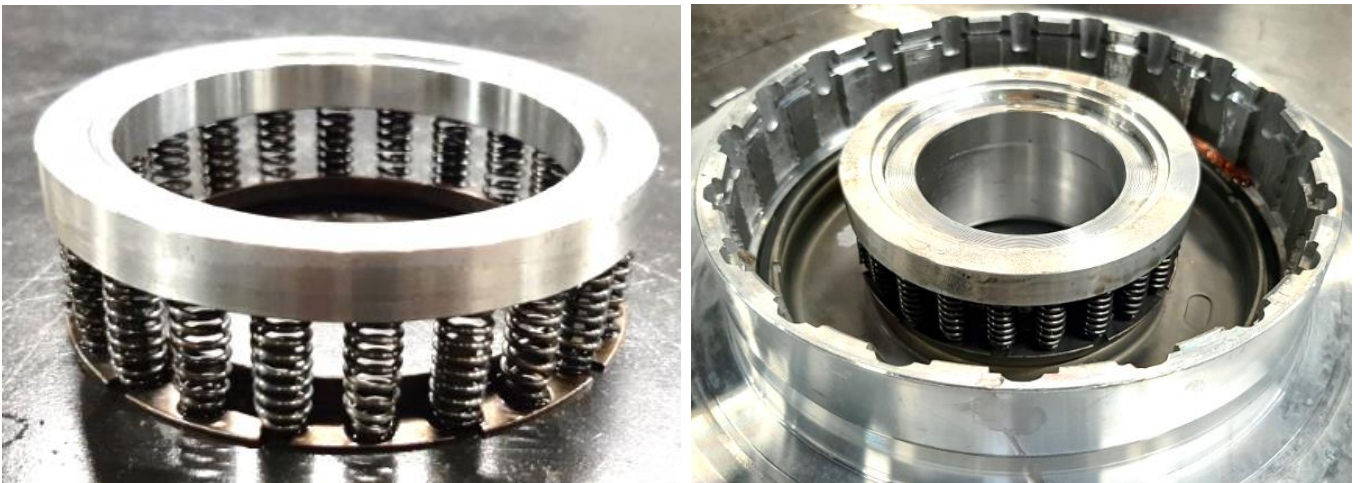



## Optional 68RFE Overdrive "Big Stack" Kit

The BD Big Stack uses a different Overdrive shaft and selector plates allowing you to fit 16 overdrive clutches. This made possible with an improved OD shaft with increased spline depth, and two billet QT100 reaction plates. This allows for a 33% increase in mechanical torque holding capacity and a 33% increase in steel thermal mass. The billet QT100 plates reduce clutch coning due to the stiffer material and geometry.





The BD Big Stack can be used in conjunction with a Sonnax input drum to allow a 16% increase in apply area. This setup will allow for a 54% increase in mechanical torque holding capacity. An electronic pressure enhancer (1030369) will further increase OD torque holding capacity.

### Kit Components – Big Stack Kits

#### 1062035

1600159	1600178	1600179
		
BD Overdrive Shaft <b>Qty: 1</b>	Reaction Plate; OD/UD <b>Qty: 1</b>	Reaction Plate: OD/Rev <b>Qty: 1</b>

#### 1062036

1600159	1600178
	
BD Overdrive Shaft <b>Qty: 1</b>	Reaction Plate; OD/UD <b>Qty: 1</b>
1600232	M1600233
	
Drum Kit; Sonnax Machined <b>Qty: 1</b>	Machined Bolt-On Plate <b>Qty: 1</b>

\*Sonnax Chisel (#1003-80) not included. Use any equivalent 1/8" Chisel.

McMaster Part # 3570A8\*

\*Clutches not included. To be used with a BD Build-it Transmission Kit

1062023 OR 1062025\*

**BD Big Stack + OEM Drum Assembly (1032035)**

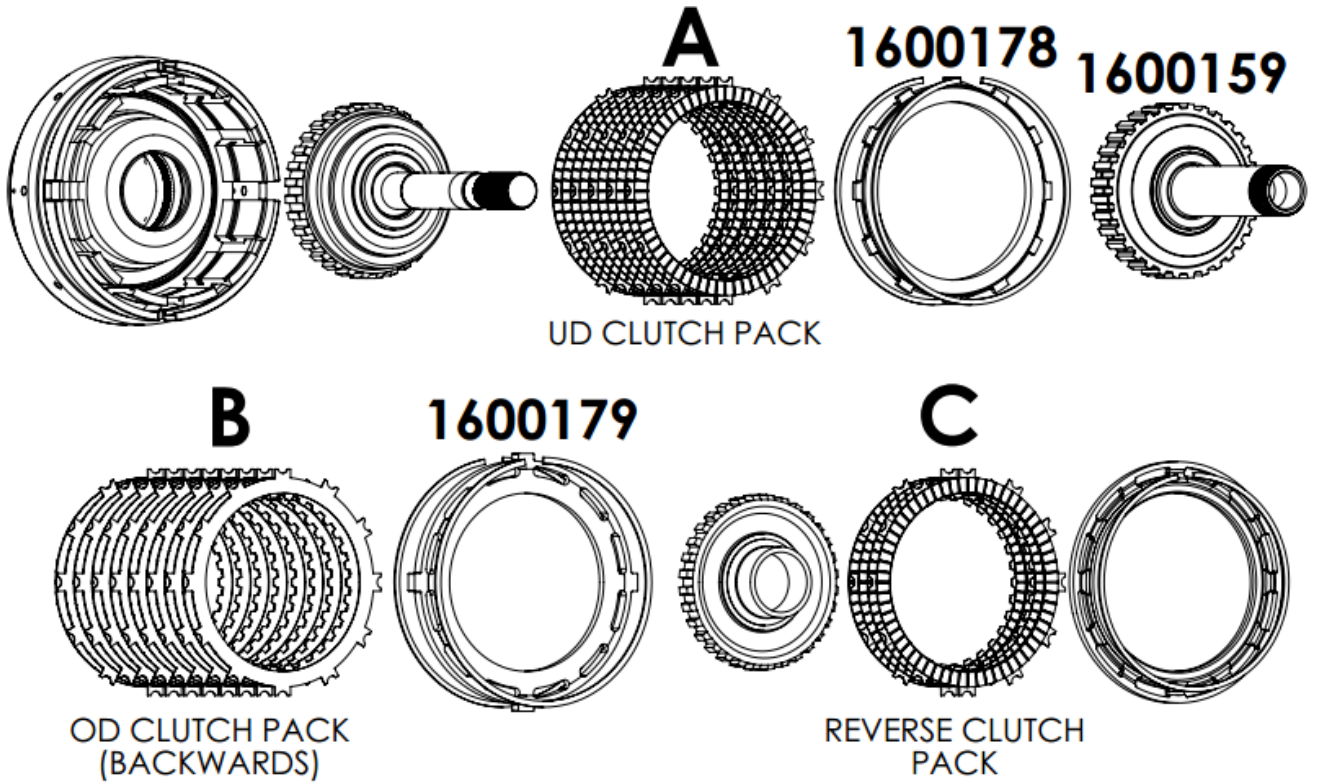

**BD Big Stack + Sonnax Drum Assembly (1062036)**

See Sonnax PN 72960-06K instructions to assemble the Sonnax drum.

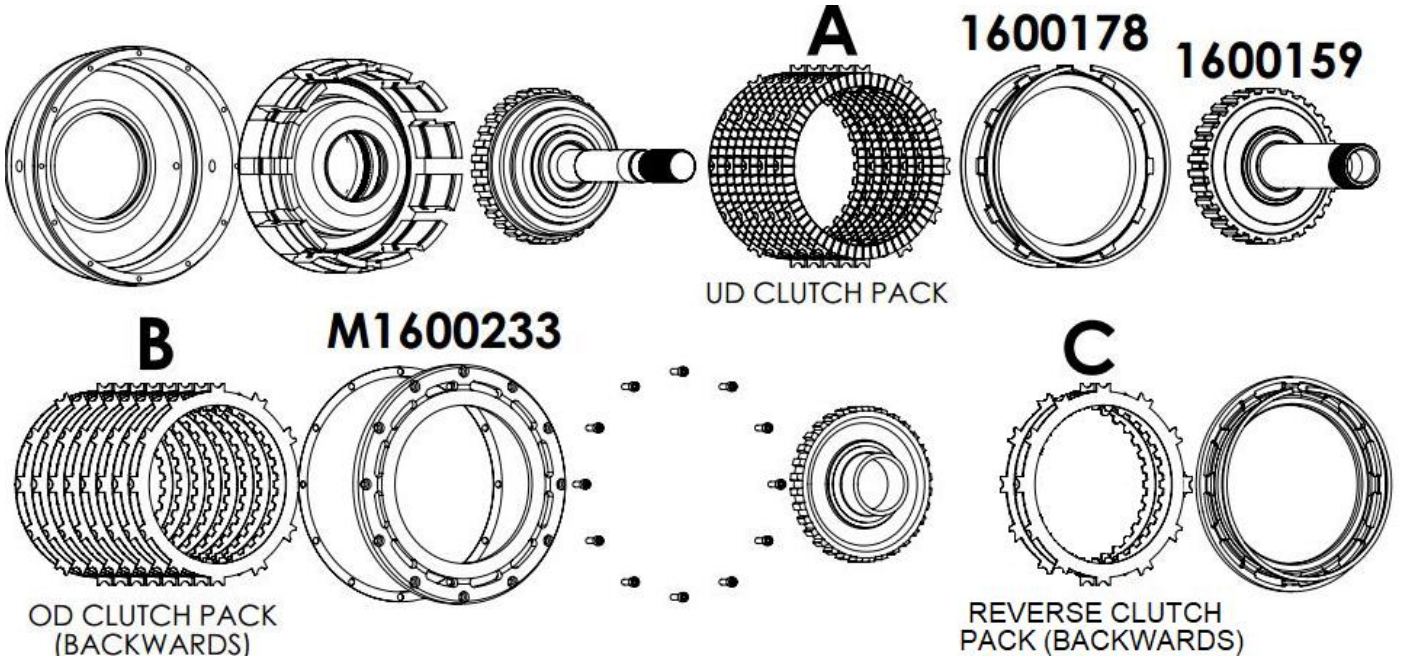

Any purchased kit from BD will have all necessary machining complete. If purchased from a separate vendor, the Sonnax bolt-on plate must be machined to fit the upside-down OD clutch plates. The bolt-on plate does not need to be resurfaced, but the face width must be increased to 6.93" (max tool radius .032").

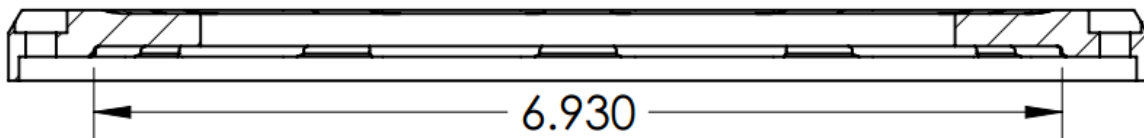

## Big Stack Clutch Clearances

Item No.	Description	Clutch Part Number	Clutch Pack Clearance	Quantity
A	Underdrive Clutch Pack	B29308L & B29309L	.040-.068"	5+5
B	Overdrive Clutch Pack	B29308L & B29309L	.040-.055"	8+8
C	Reverse Clutch Pack	B29308L & B29309L	.023-.058"	2+2*

\*Replace the OEM 2+1 double sided clutches with single sided 2+2

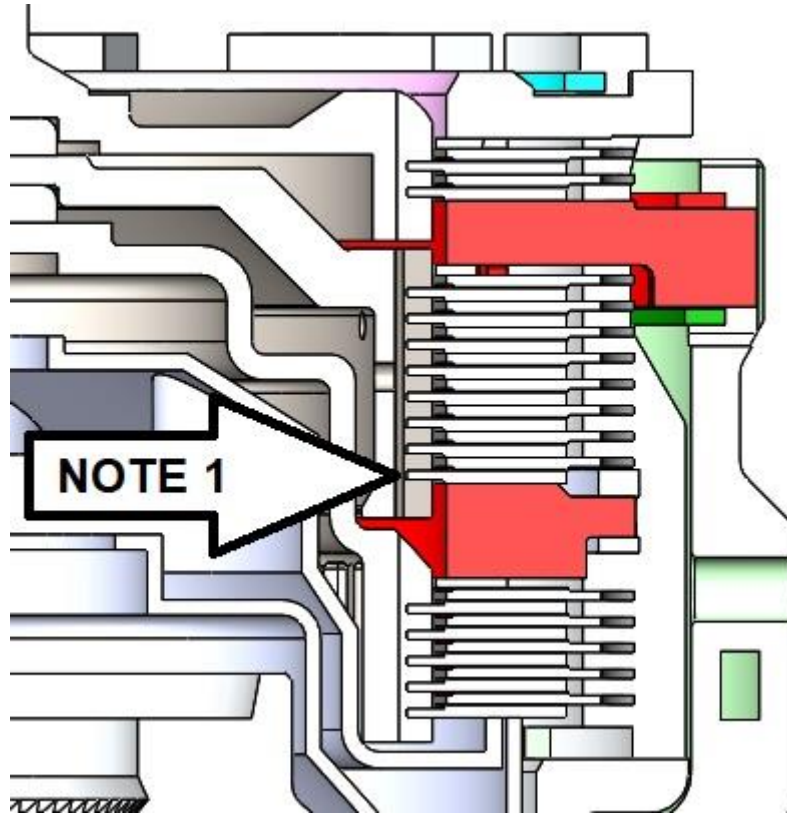

**NOTE 1: The OD clutch pack is different than a standard build. The internally splined OD clutch must be installed first with the friction surface facing downward.**

Note 2: The tapered section of the OD/UD reaction plate (1600178) must be facing upward.

Note 3: Designed to fit with Borg Warner single sided clutches. Alternate clutches may cause reduced clutch pack clearances which can cause premature failure.

Note 4: OEM snap rings MUST be used

Note 5: The standard Sonnax build will require one Anchor Shim Plate to meet the OD clutch pack clearance requirements.