

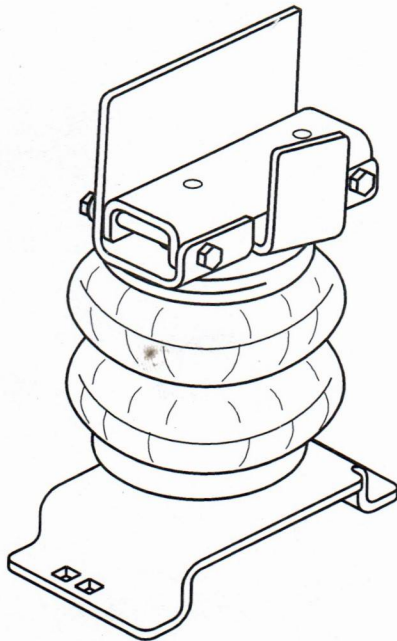

AIRIDE

firestoneairide.com

INSTALLATION INSTRUCTIONS



SECTION 1 - AIR SPRING

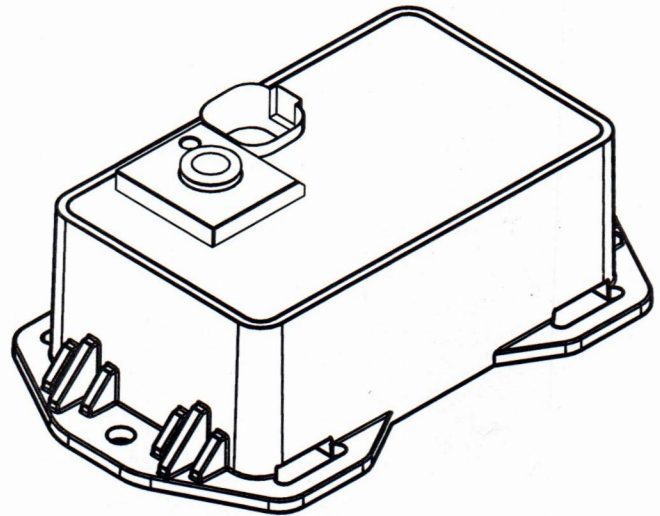

SECTION 2 - AIR ACCESSORY



riderite.com

INSTALLATION INSTRUCTIONS

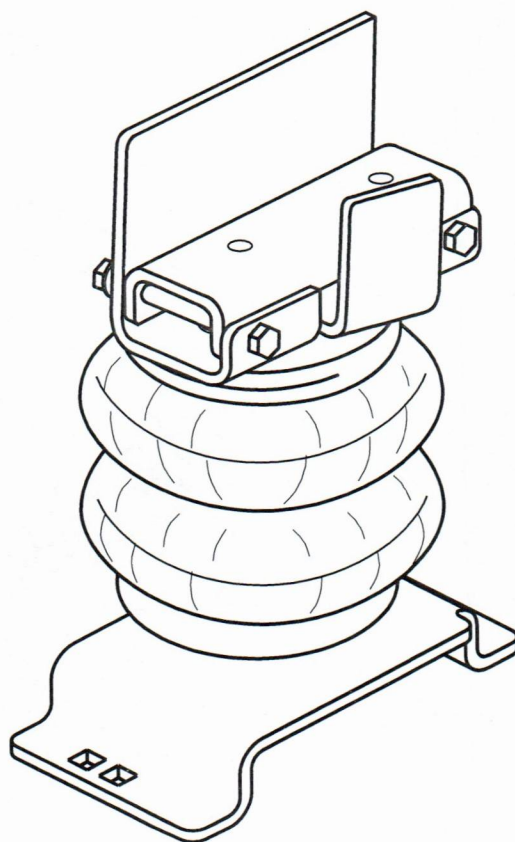

Firestone

World's Number 1
Air Spring.



FIRESTONE INDUSTRIAL PRODUCTS COMPANY

! IMPORTANT

PLEASE DON'T HURT YOURSELF, YOUR KIT OR YOUR VEHICLE. TAKE A MINUTE TO READ THIS IMPORTANT INFORMATION.

This kit is to be used on a **pickup truck only**, and **DOES NOT INCREASE YOUR VEHICLE'S MAXIMUM LOAD.**

SAFE INSTALLATION

Please take all safety precautions during installation. A hydraulic jack can fail, and if that happens, you can be seriously hurt, or worse, if you are relying on it to hold up the vehicle. If you use a hydraulic jack, secure jack stands in the appropriate locations and chock any tires still touching the ground.

Wear safety glasses or goggles. Your eyes may be lower than some parts and pieces, and you don't want to lose an eye.

Remove the possibility of any electrical issues by disconnecting the negative battery cable.

KIT CLEARANCE

There must be a minimum of 1/2" clearance around all installed components when the Air Springs are inflated and under a load. The Air Springs must flex and expand during operation, so the clearance keeps the kit from rubbing against parts of the vehicle.

VEHICLE GVWR

NEVER exceed the maximum load recommended by the vehicle manufacturer (GVWR). The GVWR can be found in your vehicle's owner's manual or on the data plate on the driver's side door. Consult your local dealership for additional GVWR specifications.

INFLATING THE AIR SPRINGS

When inflating Air Springs, add air pressure in small quantities, checking air pressure frequently. The Air Springs have much less air volume than a tire, so they inflate much more quickly.

PRESSURE TO LOAD

The Air Springs will support approximately 50 lbs. of load for each PSI of inflation pressure (per pair). For example, 50 PSI of inflation pressure will support a load of 2500 lbs. per pair of Air Springs.

APPROPRIATE AIR PRESSURE

For best ride, use only enough air pressure in the Air Springs to level the vehicle when viewed from the side (front to rear). This will vary, depending on the load, location of the load, condition of the existing suspension, and personal preference.

OPTIONAL T-FITTING

This kit includes Inflation Valves and Air Line Tube for each Air Spring, allowing you to compensate for unbalanced loads. If you prefer a single Inflation Valve system to provide equal pressure to both Air Springs, your dealer can supply the optional "T" fitting (Part # 3025 or WRI-760-3461 retail pack).

ONCE INSTALLED SUCCESSFULLY, FOLLOW THESE PRESSURE REQUIREMENTS FOR THE AIR SPRINGS:



MINIMUM PRESSURE







MAXIMUM PRESSURE (LOADED)

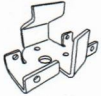
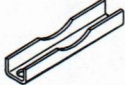
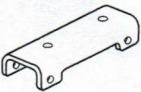

PARTS

Compare the parts below to your kit. Assure you have all pieces, and organize them for an easier installation.











MAIN KIT CONTENTS

PART # 6873		x 2 AIR SPRING	PART # 5794		x 1 RIGHT UPPER BRACKET	PART # 5808		x 2 BRACKET STRAP
PART # 5792		x 2 FRAME BRACKET	PART # 5807		x 2 LOWER BRACKET	PART # 9415		x 1 AIR LINE TUBE (22 FEET)
PART # 5793		x 1 LEFT UPPER BRACKET						

A24-760-7560 INFLATION VALVE BRACKET KIT

PART # 9483		x 1 NO-DRILL INFLATION VALVE BRACKET	PART # 9488		x 2 LARGE NYLON TIE
-------------	---	--------------------------------------	-------------	--	---------------------

A21-760-2598 HARDWARE PACK

PT # 3067		x 12 3/8" - 16 FLANGE LOCK NUT	PT # 3293		x 4 M10 x 1.5 x 30MM FLAT HEAD BOLT	PT # 9036		x 6 RED NYLON TIE
PT # 3142		x 2 3/8" - 16 x 5/8" FLAT HEAD BOLT	PT # 3032		x 2 INFLATION VALVE AND VALVE CAP ASSEMBLY	PT # 0899		x 2 THERMAL SLEEVE
PT # 3268		x 4 3/8" - 16 x 3 1/2" HEX HEAD BOLT	PT # 3031		x 2 ELBOW AIR FITTING	PT # 3033		x 4 5/16" FLAT WASHER
						PT # 3020		x 4 3/8" - 16 x 8" CARRIAGE BOLT

CONTENTS AND OVERVIEW

PAGE 4	REMOVE JOUNCE BUMPER
PAGE 5	PRE-ASSEMBLE THE LEFT SIDE AIR SPRING ASSEMBLY
PAGE 6	PRE-ASSEMBLE THE RIGHT SIDE AIR SPRING ASSEMBLY
PAGE 7	INSTALL FRAME BRACKET & FIT ASSEMBLY
PAGE 8	INSTALL UPPER BRACKET TO FRAME BRACKET
PAGE 9	INSTALL LOWER BRACKET
PAGE 10	AIR LINE TUBE & INFLATION VALVE INSTALLATION
PAGE 11	INSTALL & ROUTE AIR LINE TUBE
PAGE 12	CHECKING THE SYSTEM
PAGE 13	FIXING AN AIR LEAK
PAGE 14	FINISHING THE INSTALLATION

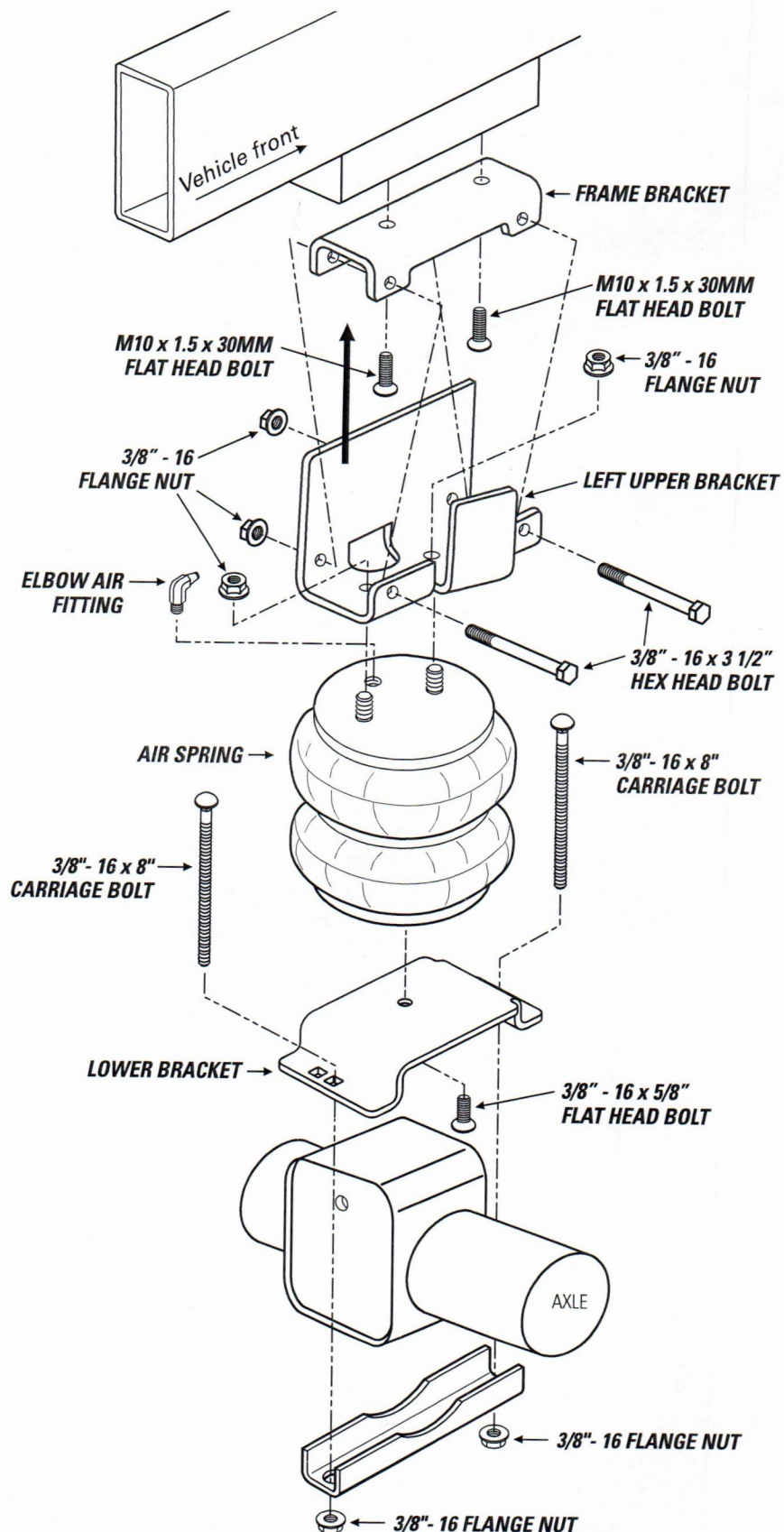



START THE INSTALLATION ON THE LEFT SIDE OF THE VEHICLE WHEN FACING FORWARD.

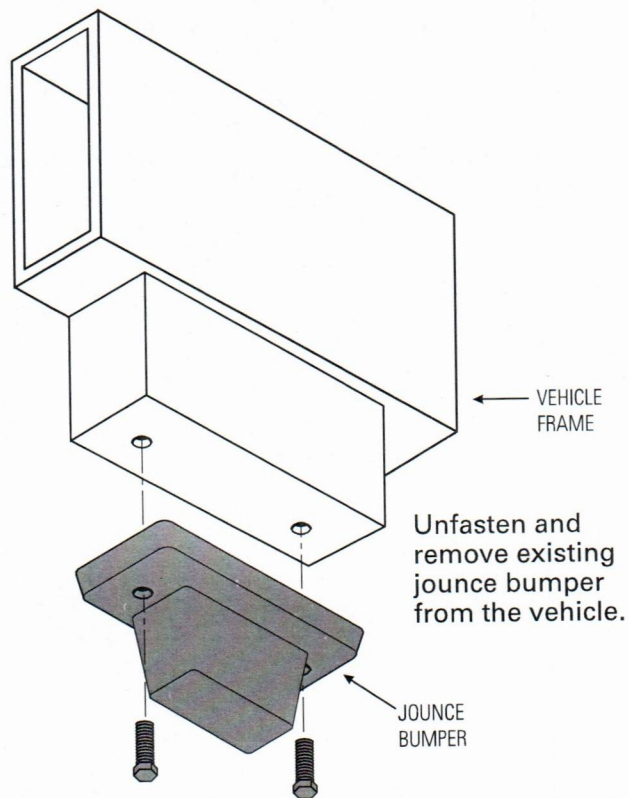

2

PRE-ASSEMBLE THE LEFT SIDE AIR SPRING ASSEMBLY

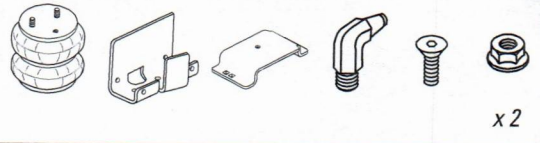

1 Fasten Upper Bracket to Air Spring, as shown.

2 Fasten the Lower Bracket to the Air Spring, hand-tighten only at this step.

3 Note that the Air Fitting should be pointing to the inside of the Upper Bracket.

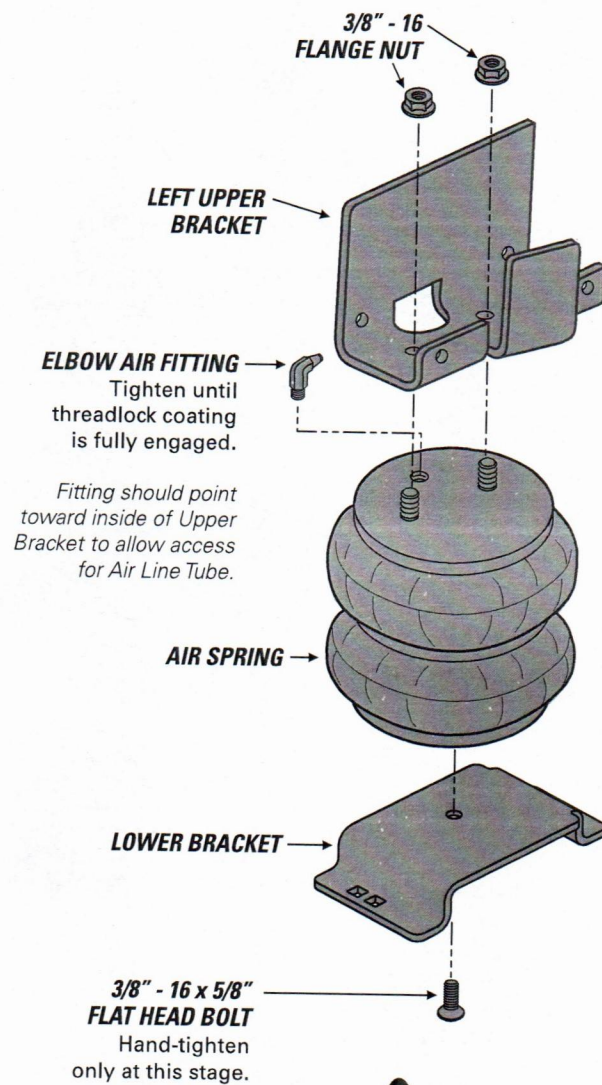

DO NOT FULLY TIGHTEN THE BOLT AT THIS STAGE. TORQUE TO SPEC IN STEP 7.

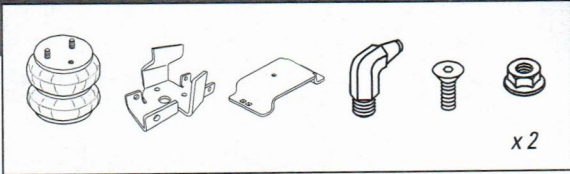

1 Fasten Upper Bracket to Air Spring, as shown.

2 Fasten the Lower Bracket to the Air Spring, hand-tighten only at this step.

3 Note that the Air Fitting should be pointing to the inside of the Upper Bracket.

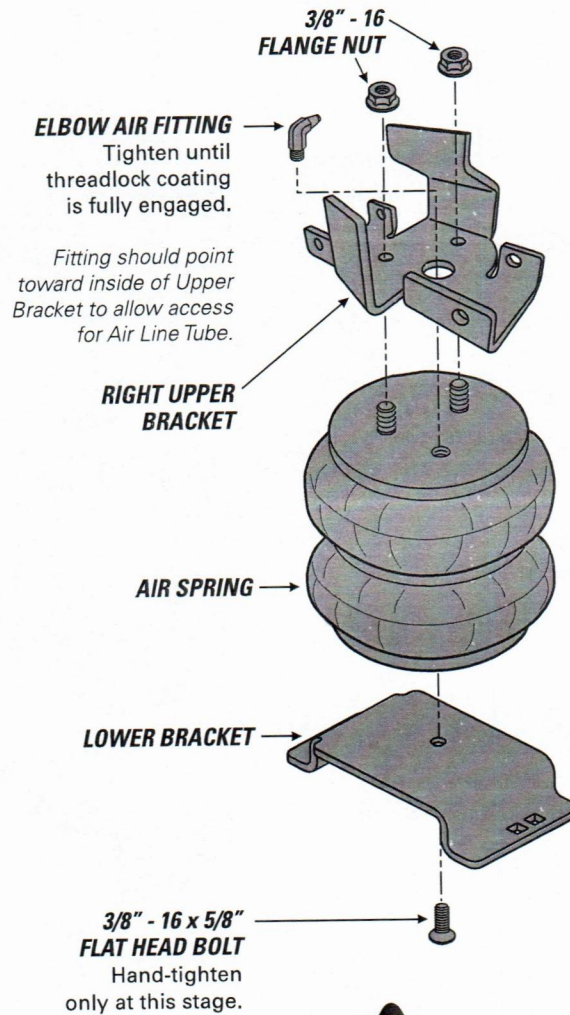

DO NOT FULLY TIGHTEN THE BOLT AT THIS STAGE. TORQUE TO SPEC IN STEP 7.

4

INSTALL THE FRAME BRACKET

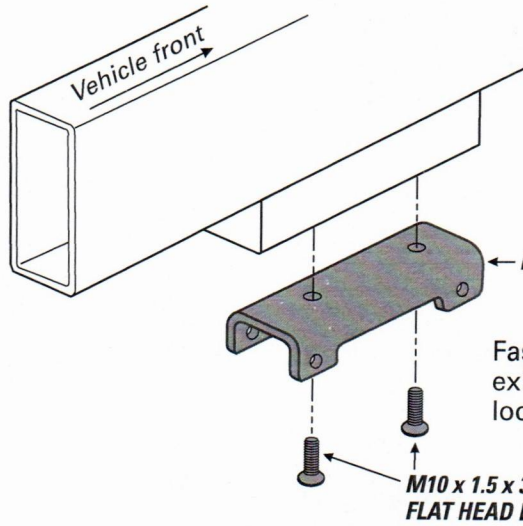
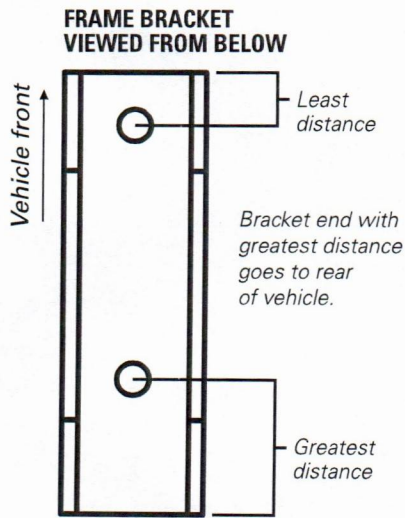
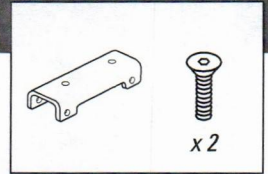

5

FIT AIR SPRING ASSEMBLY INTO PLACE ON FRAME BRACKET

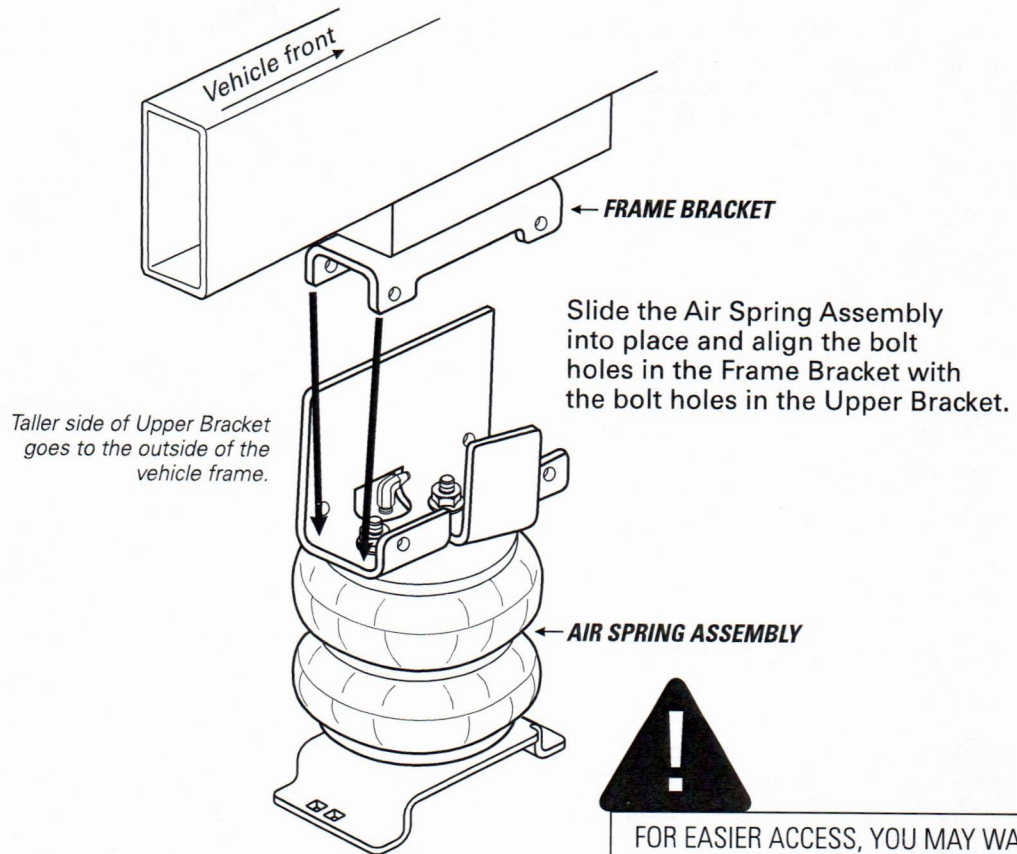

FOR EASIER ACCESS, YOU MAY WANT TO PRE-RUN THE AIR LINE TUBE TO THE AIR FITTING AT THIS STAGE.

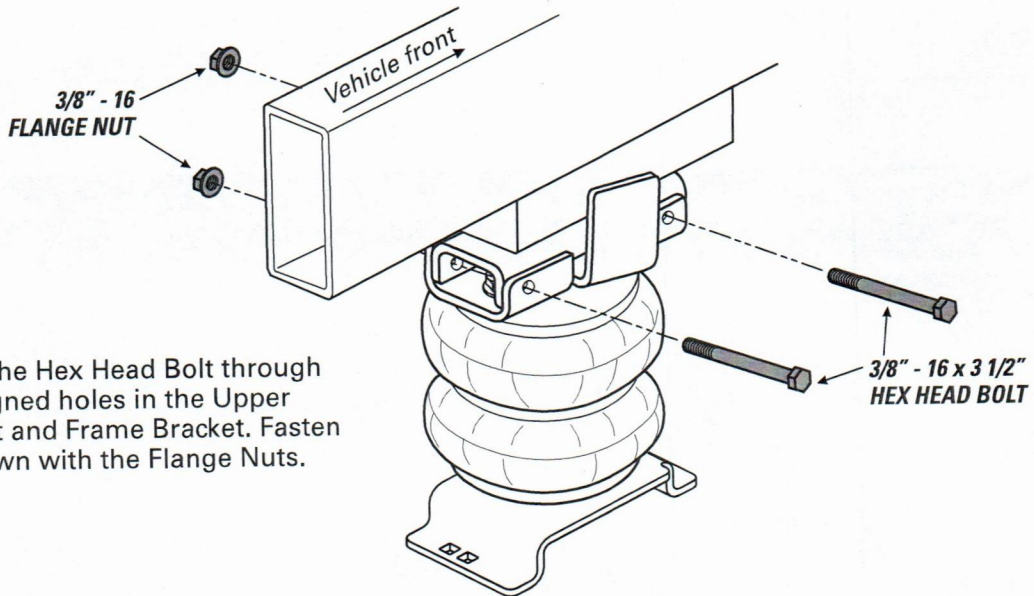
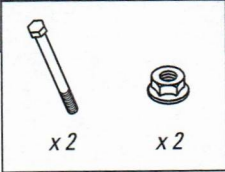

Insert the Hex Head Bolt through the aligned holes in the Upper Bracket and Frame Bracket. Fasten as shown with the Flange Nuts.

7

INSTALL LOWER BRACKET

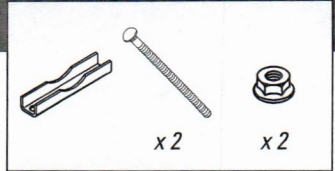

1 Follow guidelines below to dry fit assembly. Make alignment marks as shown.

2 Remove assembly and match alignment marks you made.

3 Fully tighten the 3/8\"-16 x 5/8\" Flat Head Bolt into the Air Spring.

4 Install the assembly as shown.

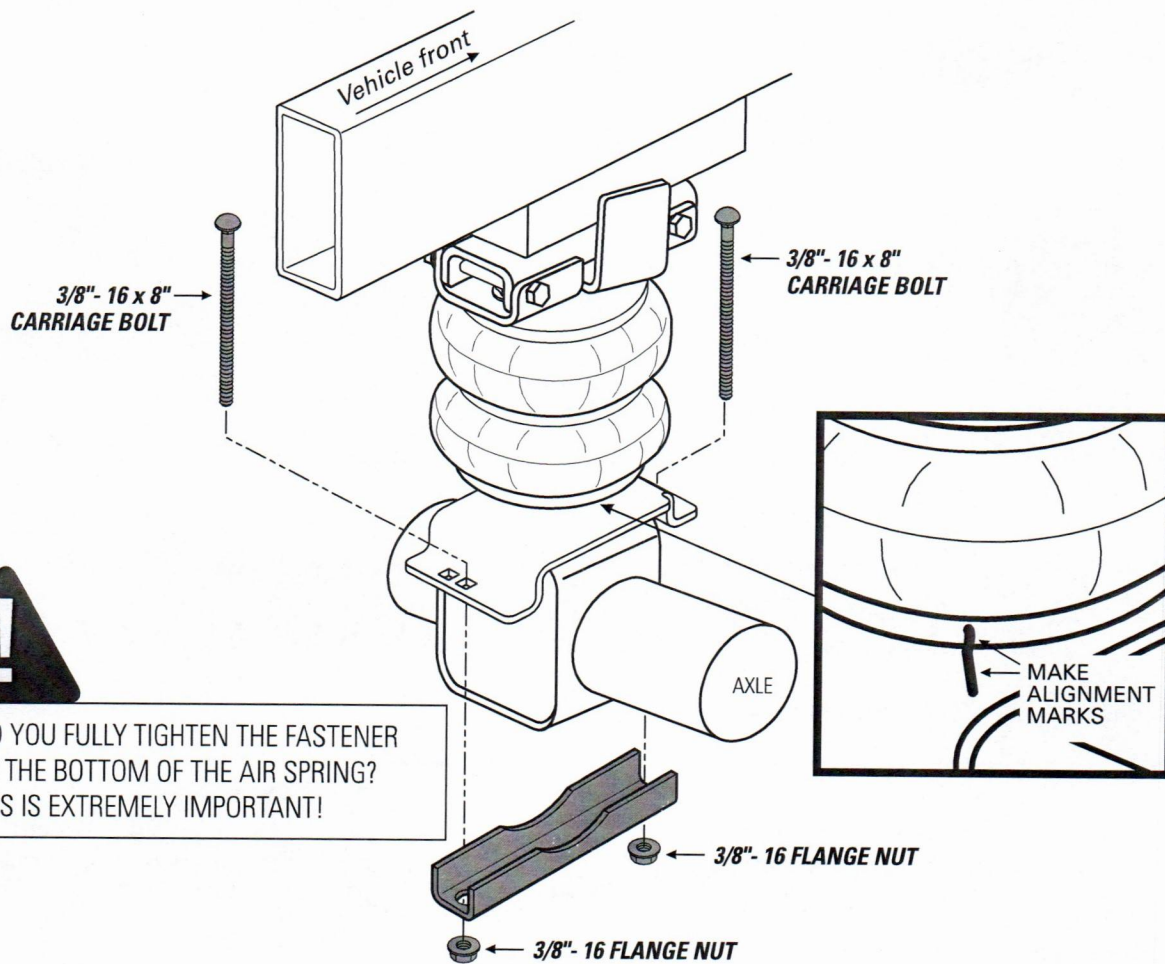

DID YOU FULLY TIGHTEN THE FASTENER ON THE BOTTOM OF THE AIR SPRING? THIS IS EXTREMELY IMPORTANT!



USE YOUR HAND TO CHECK FOR THE PROPER CLEARANCE AROUND THE AIR SPRING. IF YOUR HAND DOES NOT FIT BETWEEN THE AIR SPRING AND OTHER COMPONENTS, IT WILL RUB!



AWESOME! You're done with the left side. The right side uses a different Upper Bracket (shown in Step 3), but the guidelines still apply. Go complete Steps 1-7 for the right side, then continue to Step 10.

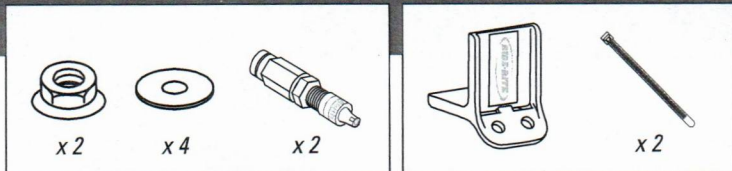

IF USING THE OPTIONAL NO-DRILL INFLATION VALVE BRACKET, CHOOSE OPTION 1. IF DRILLING, CHOOSE OPTION 2. **INFLATION VALVES MUST BE ACCESSIBLE BY AN AIR CHUCK.**

1 Secure the Air Inflation Valve Bracket to a protected, secure location. **PROCEED TO STEP 3.**

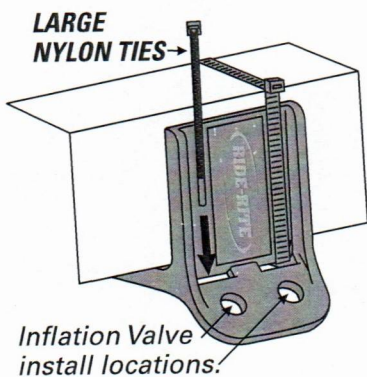

2 Select a protected location to install the Inflation Valves, such as the bumper or the body of the vehicle.

Drill two 5/16" holes for Inflation Valve install locations.

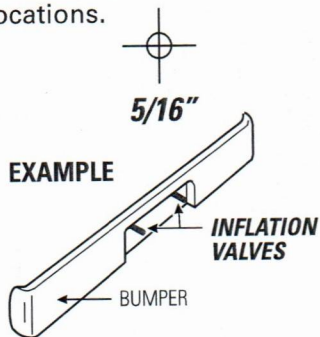

3 Install Inflation Valve assembly as shown.

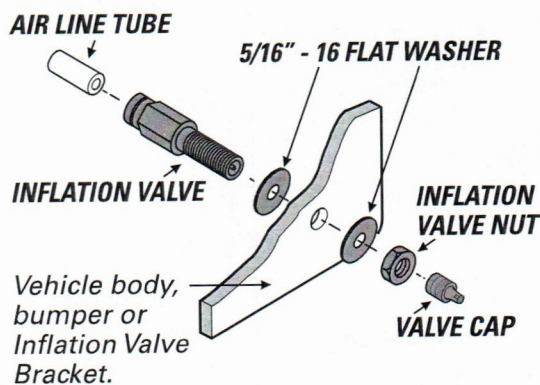

1 Match Air Line Tube ends.



2 Find center of Air Line Tube, make a square cut with tube cutter or sharp utility knife.

DO

Make sure the cut is as square as possible. Use a tube cutter or sharp utility knife.

DON'T

Fold or kink the Air Line Tube. Cut the Air Line Tube at an angle. Use pliers, scissors, snips, saws, or side cutters.

PROPER AND IMPROPER CUTS IN THE AIR LINE TUBE

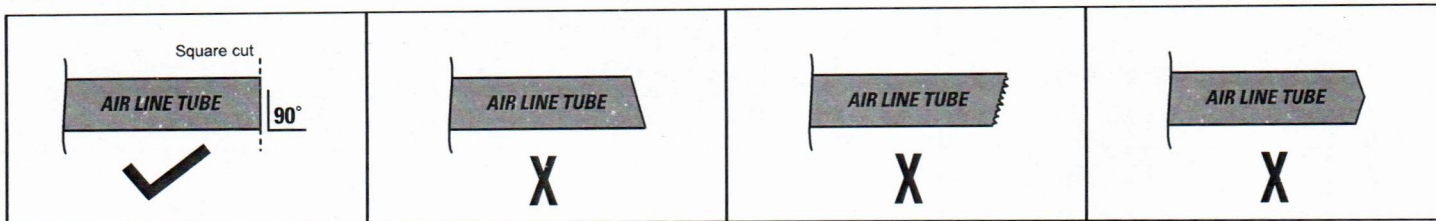

10

INSTALLING AIR LINE TUBE INTO AIR FITTINGS AND INFLATION VALVE

1 Insert end of Air Line Tube into Air Fitting.

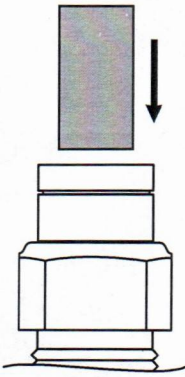

2 Push Air Line Tube into Air Fitting as far as possible.

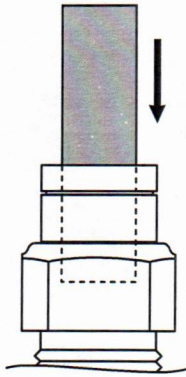

3 Gently pull on the Air Line Tube to check for a secure fit.

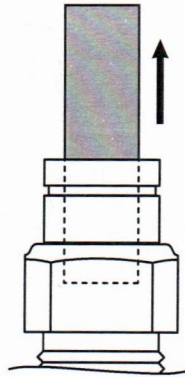

4 To remove, push down collar and gently pull Air Line Tube away.

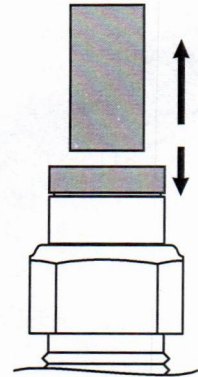

Removal Tip: Use a 1/4", 5/16", or 6mm open-ended wrench to push the collar down.

11

ROUTE AND SECURE AIR LINE TUBES

Air Line Tube routes will vary, depending on your truck, and requires you to choose the best path from the Air Springs to the Inflation Valves. Use the instructions below to help you choose.

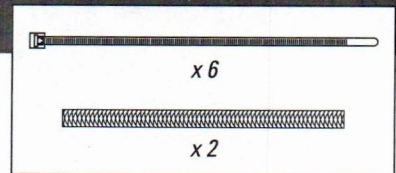

DO

Select routes protected from heat, debris, and sharp edges. Use Thermal Shields near heat sources. Use Nylon Ties to secure the Air Line Tube.

DON'T

Bend or sharply curve Air Line Tubes. Leave Air Line Tube exposed to sharp edges. Use unnecessary lengths of Air Line Tube. Route Air Line Tube near moving parts. Let Air Line tube hang unsecured from vehicle. Scar Air Line Tube while routing.

AIR LINE TUBE THERMAL SHIELD

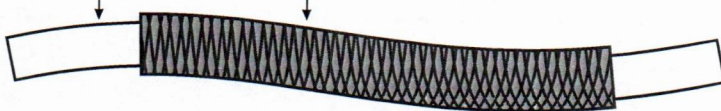

USE SUPPLIED THERMAL SHIELDS WHEN AIR LINE TUBE RUNS **WITHIN 6 INCHES** OF HEAT SOURCES.

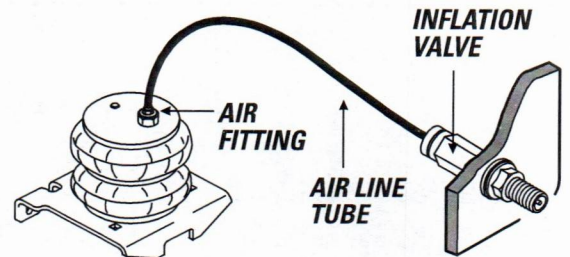

- 1** Place an air chuck onto the Inflation Valve and fill the system to **70 PSI**.

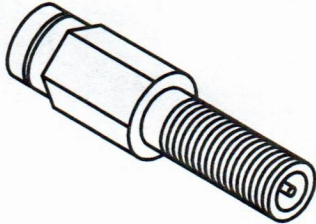

AIR SPRINGS INFLATE QUICKLY. CHECK AIR PRESSURE WHILE INFLATING.

- 2** Spray fittings with soap and water mixture.

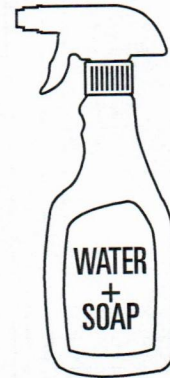

- 3** Observe bubbles.

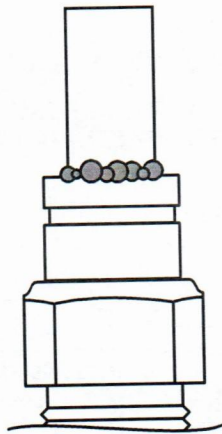

**SMALL SOAP BUBBLES
THAT DO NOT EXPAND**

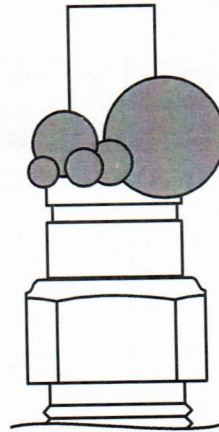

**SOAP BUBBLES
THAT EXPAND**



NO LEAKS?

Congratulations! Continue to Step 14 to finish installation. Review the Operating Instructions.

LEAK?

Bummer. Continue to Step 13 to fix the leak.

13

FIXING AN AIR LEAK

- 1 Press the air valve on end of Inflation Valve to release all air pressure.

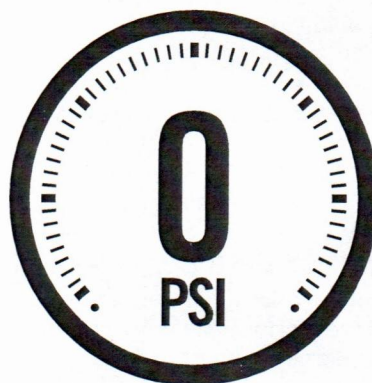
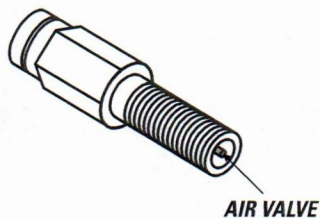

EXHAUST ALL AIR FROM THE SYSTEM PRIOR TO RELEASING AIR LINE TUBES FROM AIR FITTINGS.

LEAK AT AIR LINE TUBE AND AIR FITTING

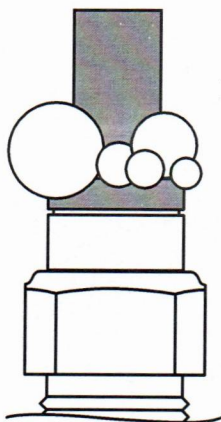

Release Air Line Tube (see page 11). Review proper cuts and procedures in Step 9. Repeat Steps 10 and 12.

LEAK AT BASE OF AIR FITTING ON AIR SPRING

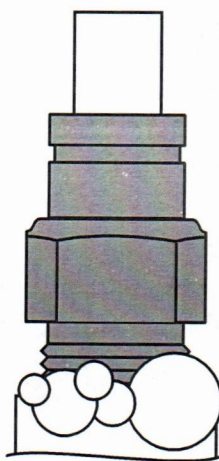

Tighten Air Fitting one turn or until leak stops.

LEAK OUT OF THE VALVE CORE ON INFLATION VALVE



Tighten valve core with valve core wrench on Inflation Valve Cap.

STILL HAVE A LEAK?

Refer to the Troubleshooting section of the Instruction Manual. If the leak persists, or if there is an issue with a leaking part, call 1-800-888-0650; Option 1; Option 1 for Tech Support.

SAFELY RETURN VEHICLE TO OPERATIVE STATE

If you removed any wheels during installation, install the wheels and torque the lug nuts to the manufacturer's specifications.

Safely remove any jack stands and wheel chocks used during installation.

Re-attach the negative battery cable.

DOUBLE-CHECK AIR SPRING CLEARANCE

Check the Air Springs once again for the proper 1/2" minimum clearance. Perform clearance check again when vehicle is under load.

VEHICLE GVWR

NEVER exceed the maximum load recommended by the vehicle manufacturer (GVWR). The GVWR can be found in your vehicle's owner's manual or on the data plate on the driver's side door. Consult your local dealership for additional GVWR specifications.

READ AND UNDERSTAND THE OPERATING INSTRUCTIONS

The Ride-Rite system can improve handling and comfort. Take the time to learn how to properly use and maintain your investment by reading the Operating Instructions.



USE YOUR HAND TO CHECK FOR THE PROPER CLEARANCE AROUND THE AIR SPRING. IF YOUR HAND DOES NOT FIT BETWEEN THE AIR SPRING AND OTHER COMPONENTS, IT WILL RUB!

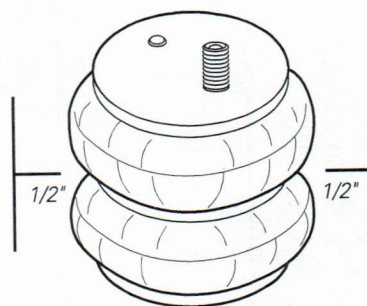

! IMPORTANT

A MINIMUM OF 5 PSI MUST BE MAINTAINED IN THE AIR SPRINGS AT ALL TIMES

Too much air pressure in the Air Springs will result in a firmer ride, while too little air pressure will allow the Air Springs to bottom out over rough conditions, and will not provide the improvement in handling that is possible.



MINIMUM PRESSURE

-



MAXIMUM PRESSURE (LOADED)



AIRIDE

firestoneairide.com

BEFORE YOU DRIVE, CONFIRM THE FOLLOWING:

- Do you have a minimum of 5PSI in your Air Springs?
- Are your Air Springs standing 5 1/2" - 7" tall?
- Are your Air Springs properly aligned, left-to-right and front-to-back?
- Are your nuts and bolts tight?
- Put your paper work back into the sleeve and keep it in your glove compartment for future reference.
- You've been bagged...and now your suspension is Airide™ equipped! Show it off with the supplied decal!

5 1/2" - 7"

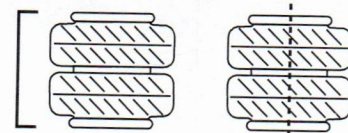

NEED INSTALLATION HELP?

Email us at rrtech@fsip.com. Please include photos, kit number, and the year, make, and model of the vehicle to help us better diagnose and understand any problems you may be experiencing.

CONNECT WITH US



@FirestoneAiride



FirestoneAiride



Firestone Airide



AIRIDE

firestoneairide.com

INSTALLATION INSTRUCTIONS

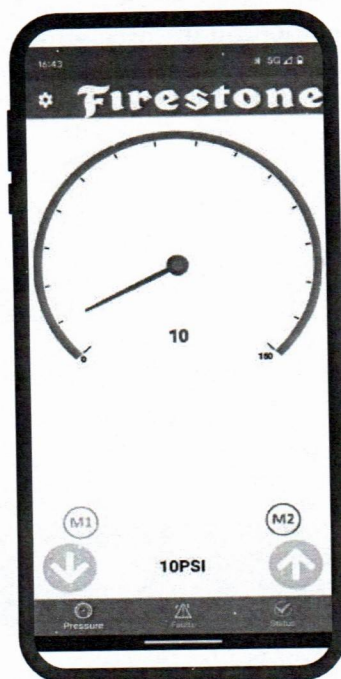
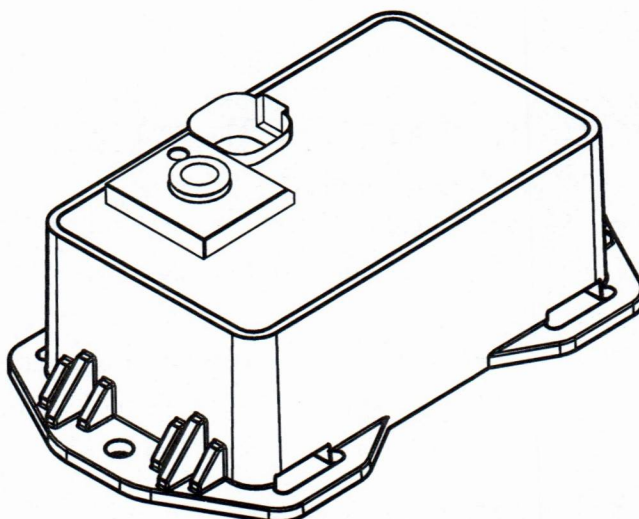

IMPORTANT

PLEASE DON'T HURT YOURSELF, THE KIT, OR YOUR VEHICLE. TAKE A MINUTE TO READ THIS IMPORTANT INFORMATION.

SAFE INSTALLATION

Please take all safety precautions during installation. A hydraulic jack can fail, and if that happens, you can be seriously hurt, or worse, if you are relying on it to hold up the vehicle. If you use a hydraulic jack, secure jack stands in the appropriate locations and chock any tires still touching the ground.

Wear safety glasses or goggles. Your eyes may be lower than some parts and pieces, and you don't want to lose an eye.

Remove the possibility of any electrical issues by disconnecting the negative battery cable.

VEHICLE GVWR

NEVER exceed the maximum load recommended by the vehicle manufacturer (GVWR). The GVWR can be found in your vehicle's owner's manual or on the data plate on the driver's side door. Consult your local dealership for additional GVWR specifications.

PRESSURE TO LOAD

Be sure to review the load limits noted in the Air Spring Kit Installation Instructions (sold separately).

APPROPRIATE AIR PRESSURE

For best ride, use only enough air pressure in the Air Springs to level the vehicle when viewed from the side (front to rear). This will vary, depending on the load, location of the load, condition of the existing suspension, and personal preference.

**ONCE INSTALLED SUCCESSFULLY, FOLLOW THE PRESSURE REQUIREMENTS FOR THE AIR SPRINGS.
FOR FIRESTONE, GENERALLY:**

COIL-RITE

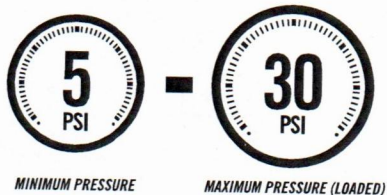

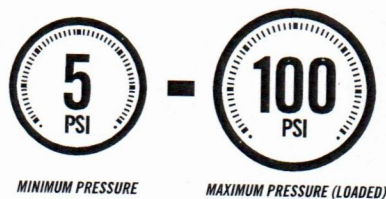

RIDE-RITE



PARTS

Compare the parts below to your kit. Assure you have all pieces, and organize them for an easier installation.

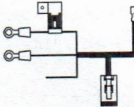
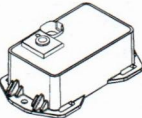
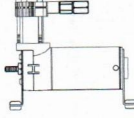





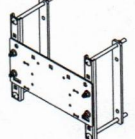



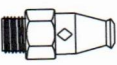

MAIN KIT CONTENTS

PT # 9534	 x 1 WIRE HARNESS	PT # 9535	 x 1 ECU	PT # 9523	 x 1 AIR COMPRESSOR KIT
				PT # 9414	 x 1 AIR LINE TUBE (18 FEET)

A24-760-2642 COMPRESSOR AND ECU MOUNTING KIT

KIT # 2642	 x 1 SINGLE PATH MOUNTING KIT <i>The parts list for this kit is in the Mounting Kit Manual included at the end of this Manual.</i>
------------	--

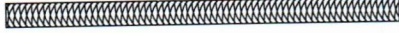
A21-760-2920 HARDWARE PACK

PT # 3087	 x 4 10-32 x 1" MACHINE SCREW	PT # 3093	 x 2 10-32 x 3/4" MACHINE SCREW	PT # 3086	 x 10 #10 FLAT WASHER
PT # 3088	 x 6 10-32 NYLOCK NUT	PT # 3055	 x 1 1/8 NPT PUSH-TO-CONNECT STRAIGHT FITTING	PT # 3032	 x 1 INFLATION VALVE AND VALVE CAP ASSEMBLY
PT # 3025	 x 3 1/4" PUSH-TO-CONNECT TEE	PT # 3421	 x 1 10-16 x 3/4" SELF-TAPPING SCREW	PT # 9036	 x 8 RED NYLON TIE
PT # 9488	 x 4 LARGE NYLON TIE	PT # 0899	 x 2 THERMAL SLEEVE	PT # 9483	 x 1 NO-DRILL INFLATION VALVE BRACKET

CONTENTS AND OVERVIEW

PAGE 4 PLANNING THE INSTALL

PAGE 5 PREPARE THE AIR COMPRESSOR

PAGE 6 DRILL HOLES FOR AIR COMPRESSOR AND ECU

PAGE 7 INSTALL THE AIR COMPRESSOR AND ECU

PAGE 8 INSTALL THE WIRE HARNESS

PAGE 9 INSTALL THE AIR LINE TUBES

PAGE 10 OPTIONAL INFLATION VALVE INSTALLATION

PAGE 11 INSTALL THE AIR FILTER AND CLEAN UP

PAGE 12 CONNECTING TO THE APP

PAGE 13 TEST THE SYSTEM

PAGE 14 FIX AN AIR LEAK

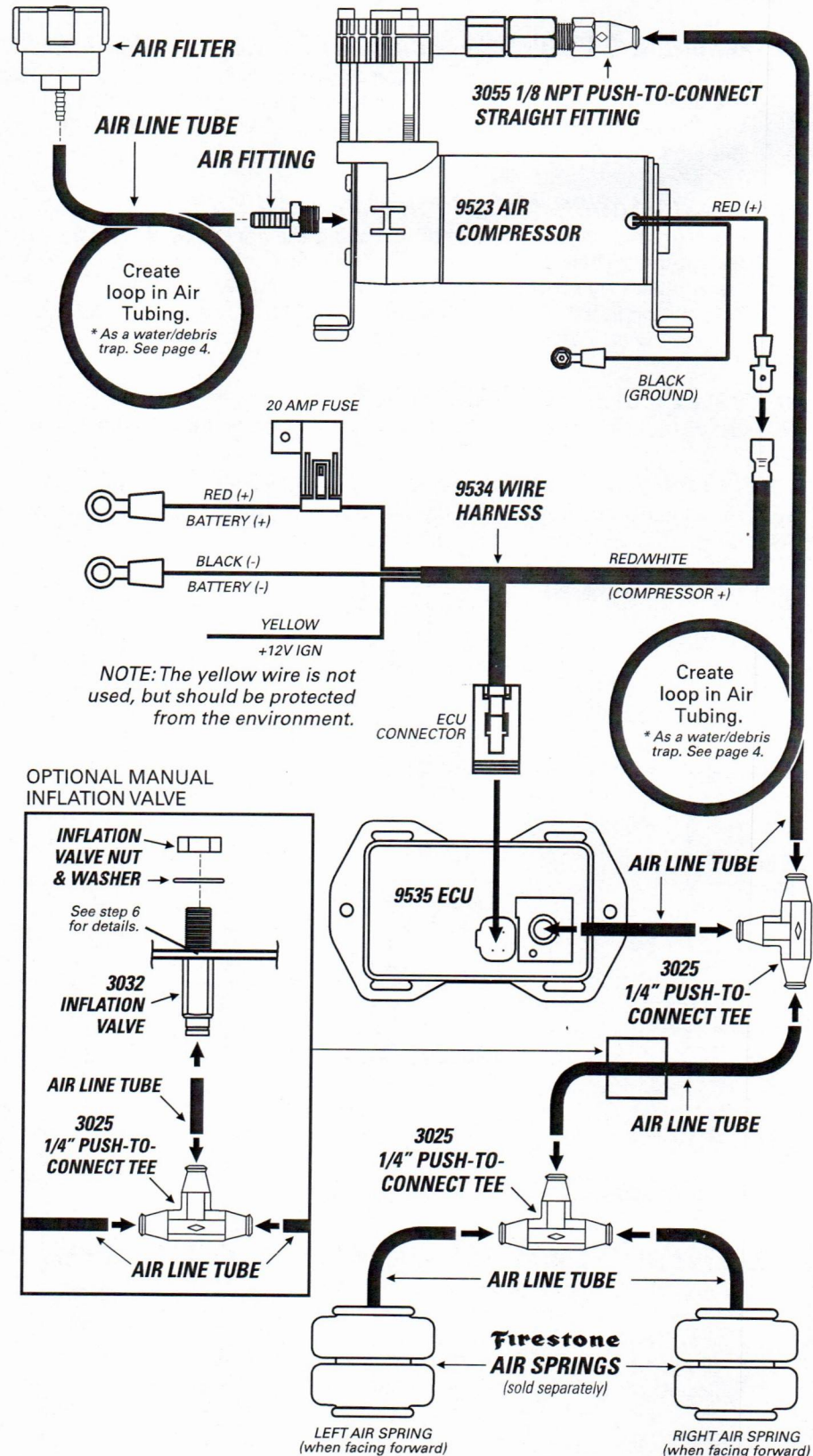

PLANNING THE INSTALL

THESE PLANNING STEPS WILL HELP YOU SAVE TIME AND WILL MAKE THE INSTALLATION EASIER.

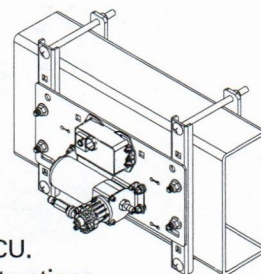

DETERMINE THE MOUNTING LOCATION FOR THE AIR COMMAND KIT

- This Kit comes with a Mounting designed specifically for the provided Air Compressor and ECU.
- Refer to the Mounting Kit Manual attached at the end of the this Kit's Manual for additional instructions.
- Consult the **OPTIONAL** instructions below and in Section 2 only if the Mounting Kit does **NOT** fit your vehicle.

PLAN INSTALLATION ROUTES FOR WIRING AND AIR LINES

- Make sure the Wire Harness and Air Tubing are not exposed to sharp metal edges that can damage them.
- Use supplied Thermal Sleeves on Air Tubing when routing near heat sources.
- Use supplied Nylon Ties to secure Air Tubing and Wire Harness to the vehicle.
- Make a loop in the Air Tubing where shown. This creates a water/debris trap that protects the Air Compressor.
- Measure twice, cut once!

TAPE ALL ELECTRICAL CONNECTIONS

- Use electrical tape to appropriately secure and protect all electrical connections.

USING PUSH-TO-CONNECT FITTINGS FOR AIR LINES

Your kit includes Push-to-Connect fittings to connect the Air Tubing to hardware. Use the instructions below when using the Air Tubing.

- 1** Insert end of Air Tubing into Air Fitting.

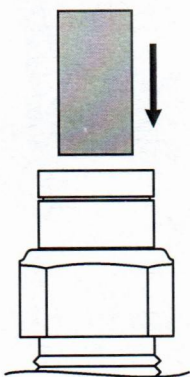

- 2** Push Air Tubing into Air Fitting as far as possible.

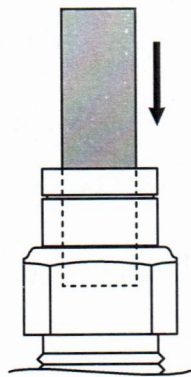

- 3** Gently pull on the Air Tubing to check for a secure fit.

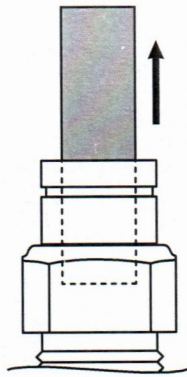

- 4** To remove, push down collar and gently pull Air Tubing away.

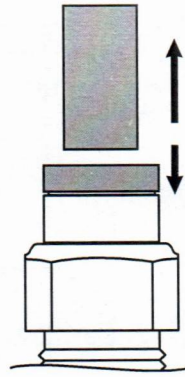

Removal Tip: Use a 1/4", 5/16", or 6mm open-ended wrench to push the collar down.

OPTIONAL

DETERMINE THE MOUNTING LOCATION FOR THE AIR COMPRESSOR AND ECU

- Mount in a location protected from airborne debris and moisture.
- Allow room for the Air Tubing to run without sharp curves or bends.
- Allow room for the Tubing to connect to the Air Fitting on the ECU.
- Allow room for the 4-pin ECU connector to connect to the ECU.
- Mount close enough together to allow Wire Harness connections to reach the Air Compressor and ECU.
- Using supplied fasteners shown in Step 3 is recommended. If no other mounting option is available, see the sidebar on Step 2 for using the Large Nylon Ties.
- Select a location that is solid and secure on the body or frame of the vehicle, away from any moving parts, electrical or any other lines.

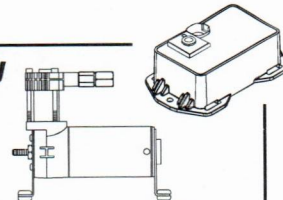

1

PREPARE THE AIR COMPRESSOR

NOTE: Air compressor can be mounted facing any direction.

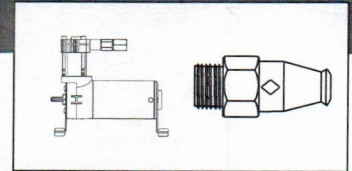

1 Install 1/8 NPT Push-to-Connect Straight Fitting on the Check Valve.

2 Install Barbed Air Fitting in Inlet Port of the Compressor from Air Compressor Kit.

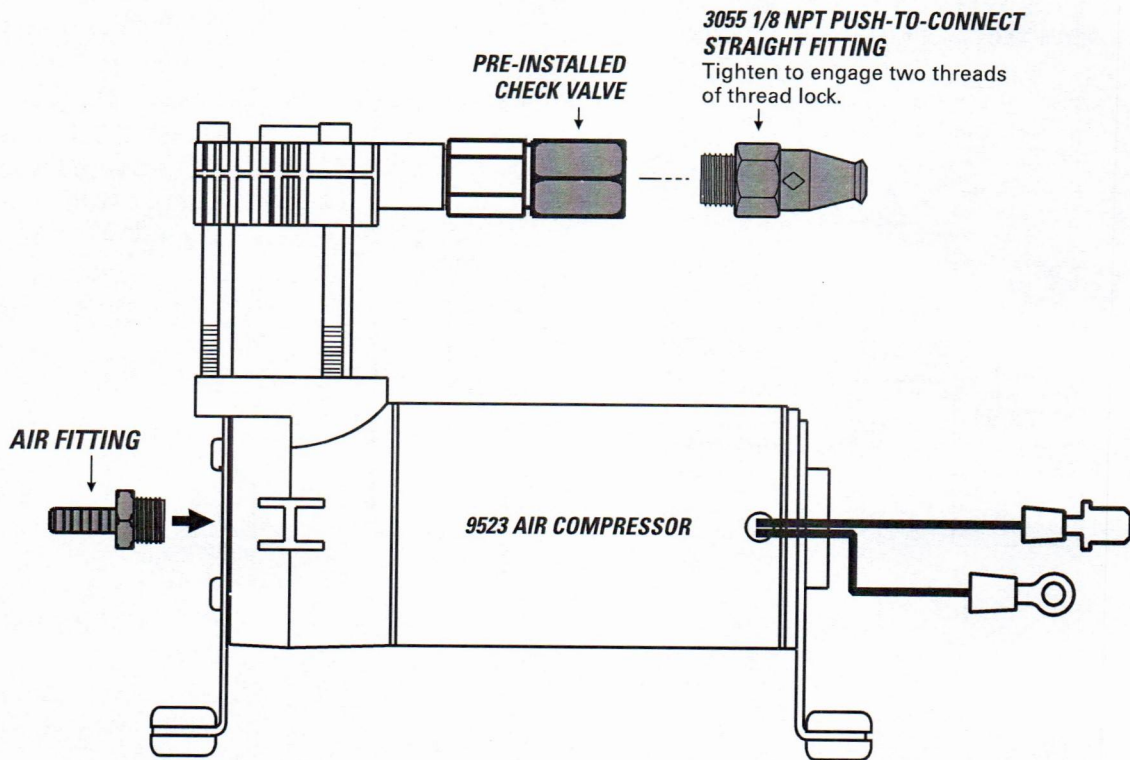

OPTIONAL - DRILL HOLES FOR AIR COMPRESSOR AND ECU

2

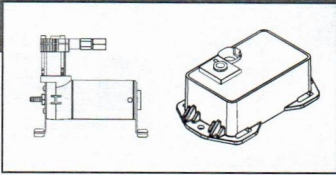

IF YOU ARE USING THE SUPPLIED FIRESTONE AIR ACCESSORY MOUNTING KIT, SKIP THIS STEP AND REFER TO THE MOUNTING KIT'S INSTRUCTIONS AT THE END OF THIS MANUAL.

STOP HERE AND SKIP THIS STEP IF USING THE PROVIDED MOUNTING KIT



CHECK SURROUNDING AREA AND BACK SIDE OF MOUNTING LOCATION TO AVOID DRILLING INTO EXISTING LINES OR WIRING.

Drill within reach of the ground wire ring terminal on body or frame of vehicle or create a wire to link to the negative battery terminal. Minimum gauge of wire should be 12.

AIR ACCESSORY MOUNTING KIT CANNOT BE USED AS A GROUNDING LOCATION FOR THE AIR COMPRESSOR.

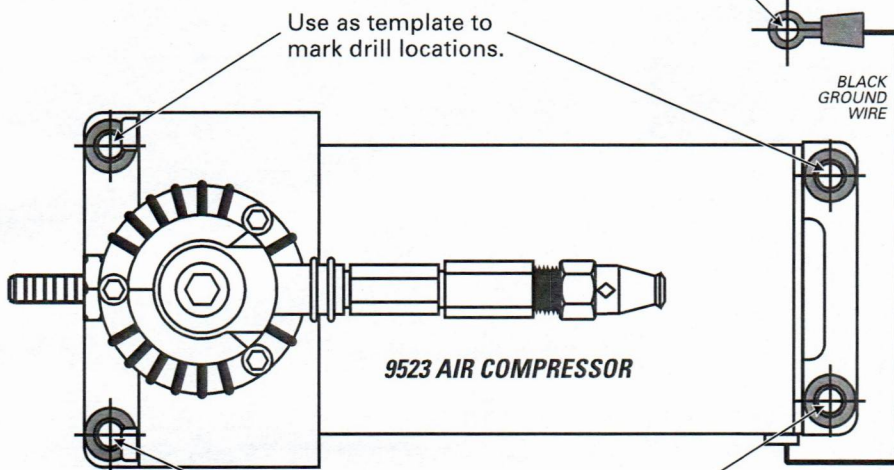

1 Using the Air Compressor and ECU as templates, mark drill locations as shown with a punch or marking tool.

2 Mark Air Compressor ground wire fastening location within reach of the ground wire ring terminal.

3 Drill 7/32" diameter holes. Remove any burrs and debris from drill holes.



ASSURE THAT YOU INSTALL THE AIR COMPRESSOR AND ECU CLOSE ENOUGH SO THE CONNECTORS ON THE WIRE HARNESS WILL REACH THEM BOTH.

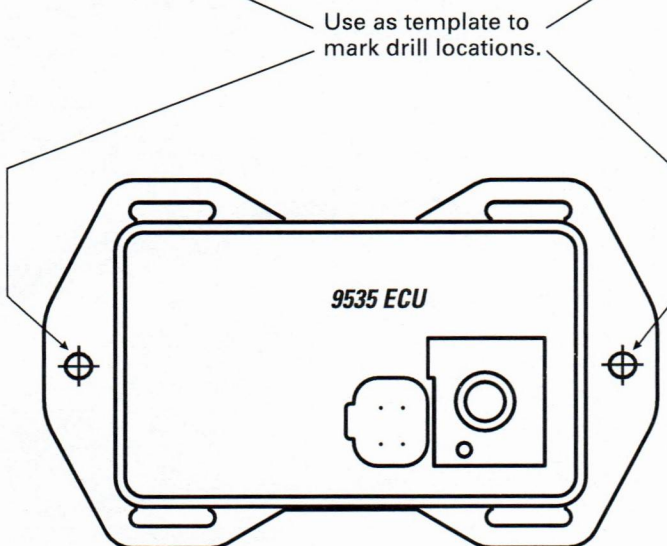

OPTIONAL ECU MOUNTING

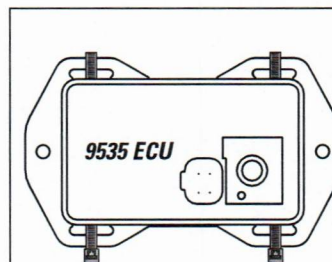

If there is no other mounting option, use two Large Nylon Ties to secure ECU to the location determined in planning the install section. Route the Nylon Ties under the ECU and around the mounting location.

3

INSTALL THE AIR COMPRESSOR AND ECU

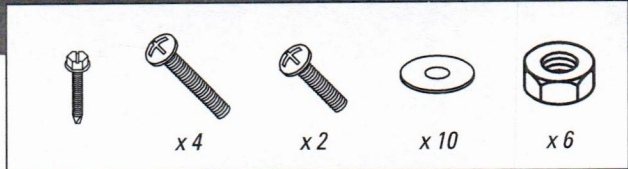

DO NOT OVER TIGHTEN MOUNTING BOLTS AND NUTS ON THE AIR COMPRESSOR. TOO MUCH TORQUE CAN CRUSH THE BRASS INSERTS AND RUBBER ISOLATORS.

1 Mount the Air Compressor to the hole locations on the provided Mounting Kit using the supplied fasteners. DO NOT OVERTIGHTEN.

2 Mount the ECU to the hole locations on the provided Mounting Kit using the supplied fasteners.

3 Mount the black ground wire ring terminal using the supplied fasteners. Assure that the ring terminal makes a solid contact with bare metal for a proper ground.

OPTIONAL

Mount to the drill holes made in the frame. Do this only if the mounting kit will not mount to the frame of the vehicle.

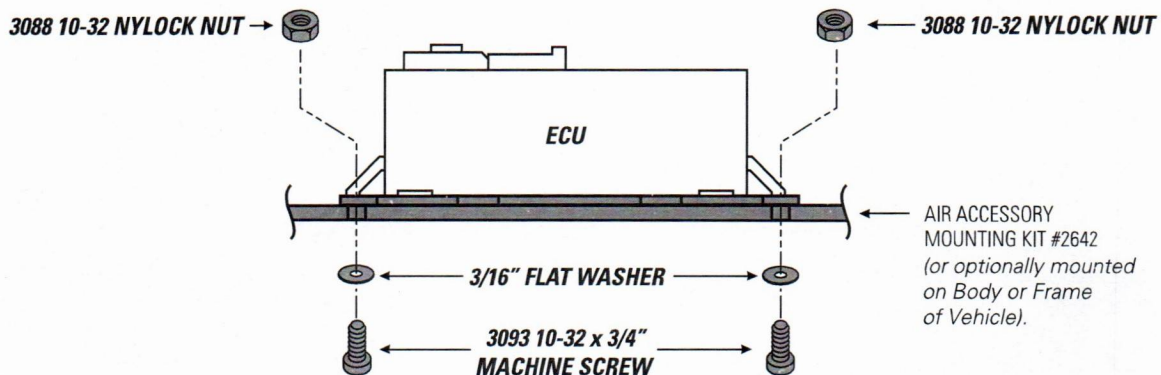
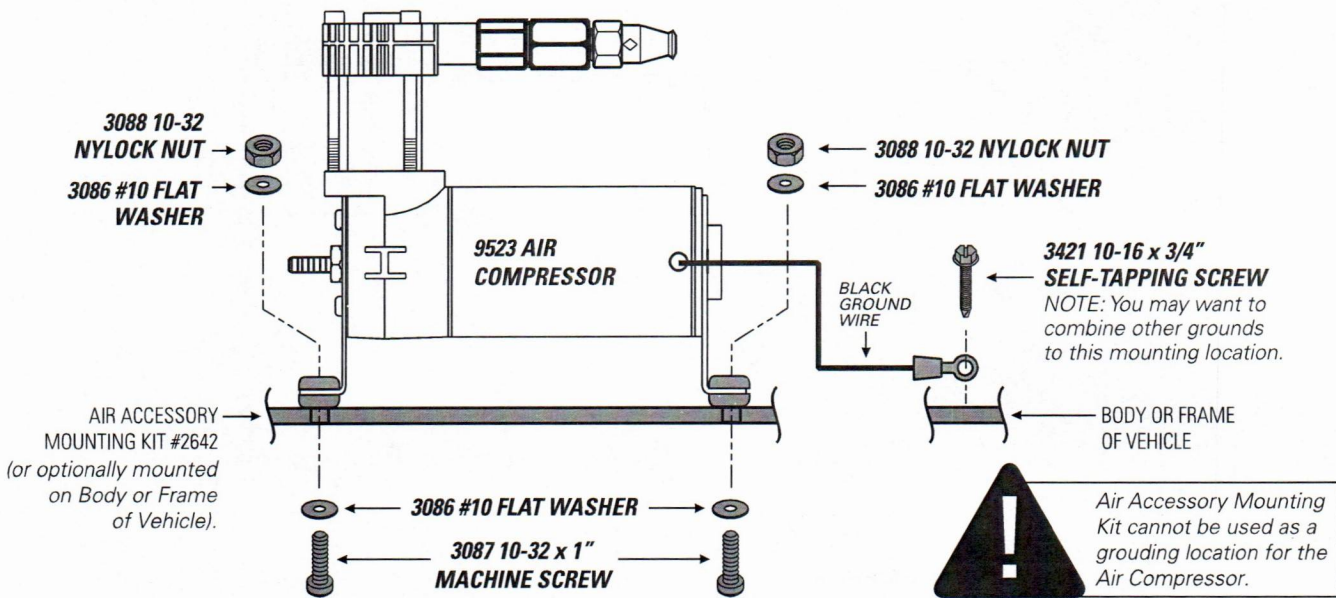

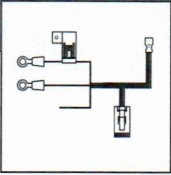

1 Route the Wire Harness in the most protected manner possible, and securely make all connections as shown.

2 The yellow wire is not used. Wrap or wire nut it to protect it from the environment.

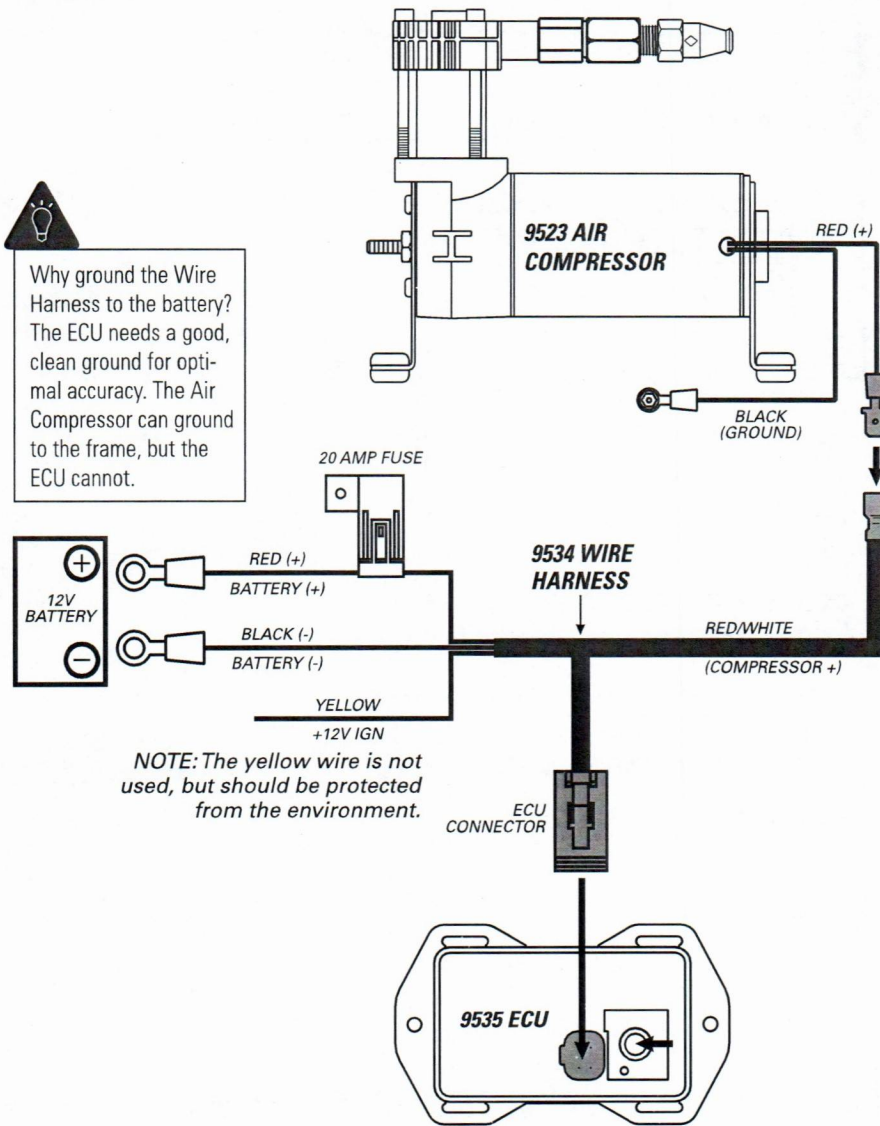

5

INSTALL AIR LINE TUBES



EXHAUST ALL AIR FROM THE SYSTEM PRIOR TO RELEASING AIR TUBES FROM AIR FITTINGS.

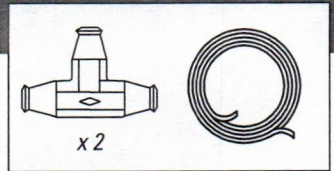

1 Route the Air Tubing from 1/8 NPT Push-to-Connect Straight Fitting on the top of the Air Compressor to the first 1/4" Push-to-Connect Tee.

2 From the 1/4" Push-to-Connect Tee, route Air Tubing to the ECU, as shown.

3 Route Air Tubing from each Air Spring and connect to a 1/4" Push-to-Connect Tee, as shown.

4 Route Air Tubing to connect the two 1/4" Push-to-Connect Tees, as shown.

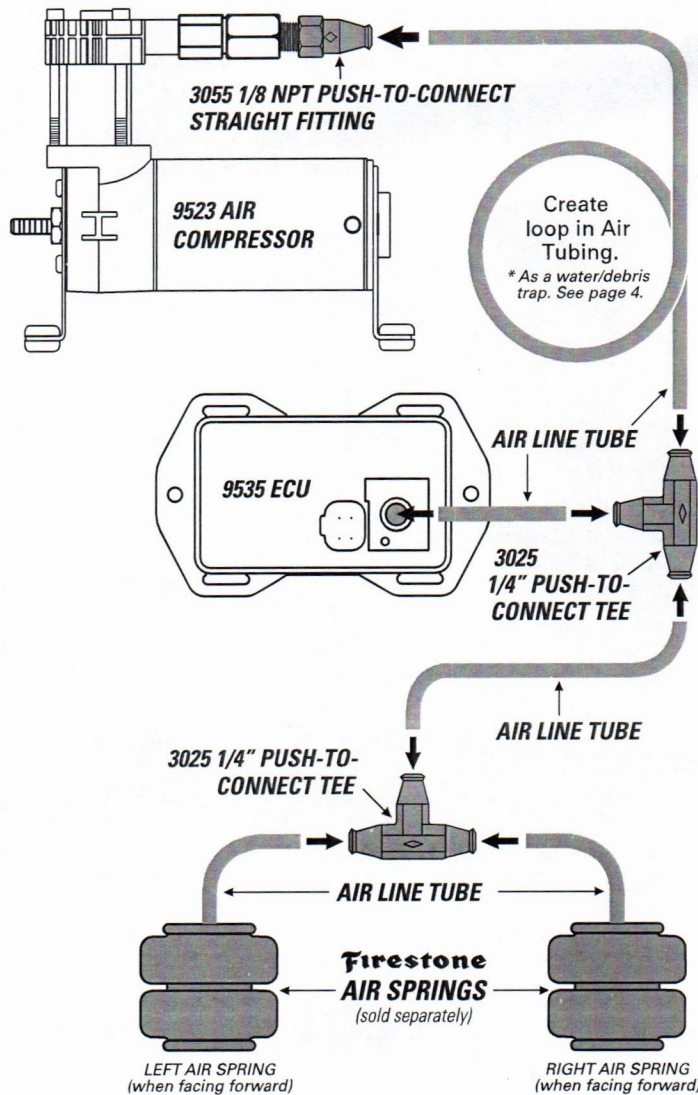

DO

Make sure the cut is as square as possible. Use a tube cutter or very sharp utility knife.

DON'T

Fold or kink the Air Tubing. Cut the Air Tubing at an angle. Use pliers, scissors, snips, saws, or side cutters.

PROPER AND IMPROPER CUTS IN THE AIR TUBING

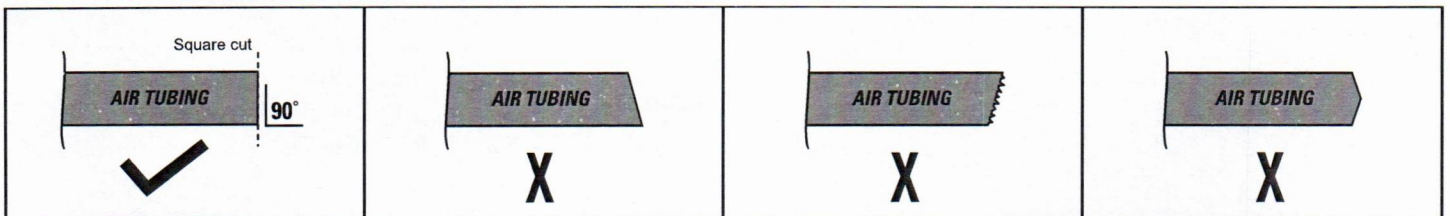

OPTIONAL INFLATION VALVE INSTALL

6

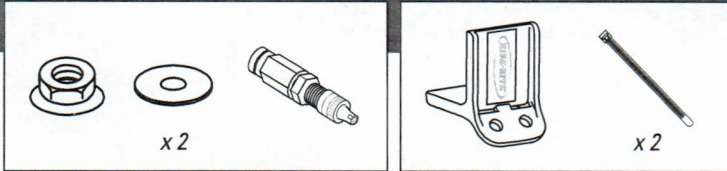

IF USING THE OPTIONAL NO-DRILL INFLATION VALVE BRACKET, CHOOSE OPTION 1. IF DRILLING, CHOOSE OPTION 2. **INFLATION VALVE MUST BE ACCESSIBLE BY AN AIR CHUCK.**

1 Secure the Air Inflation Valve Bracket to a protected, secure location. PROCEED TO STEP 3.

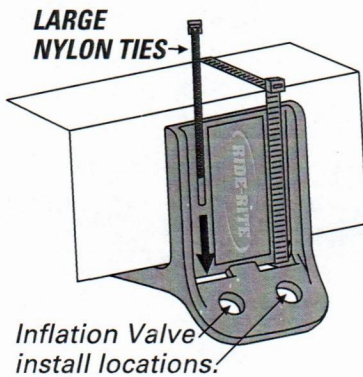

2 Select a protected location to install the Inflation Valve, such as the bumper or the body of the vehicle.

Drill a 5/16" hole for Inflation Valve install location.

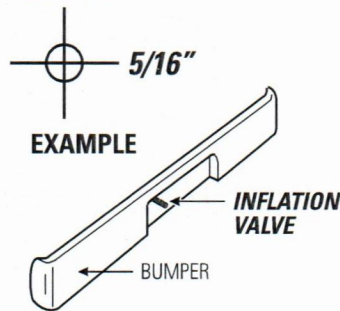

3 Install Inflation Valve Assembly as shown.

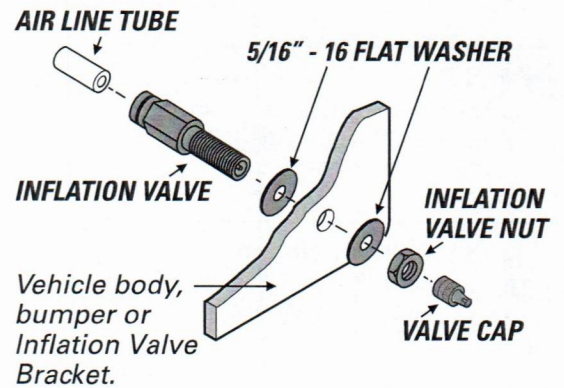

RUN AIR LINE TO OPTIONAL INFLATION VALVE

7

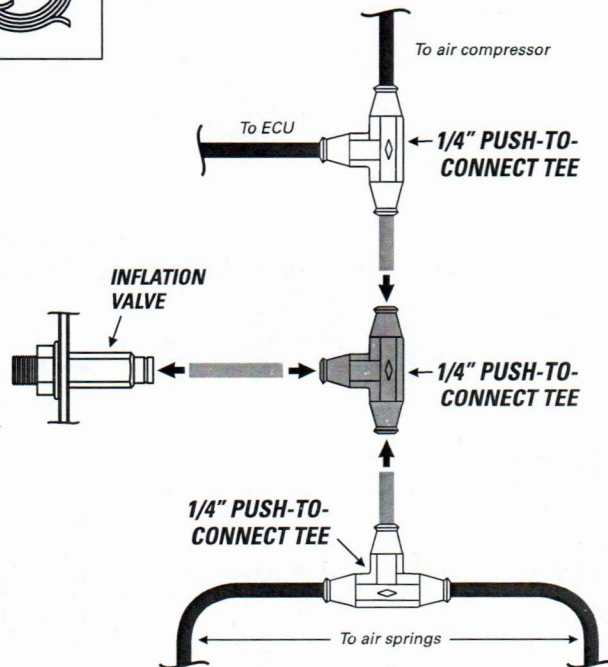
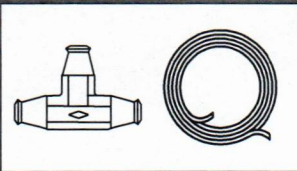

1 Run Air Tubing from the location of the installed Inflation Valve in Step 6 to the Air Tubing that connects the two installed 1/4" Push-to-Connect Tees.

2 Cut the piece of Air Tubing that connects the two installed 1/4" Push-to-Connect Tees.

3 Install the Air Tubing into the 1/4" Push-to-Connect Tee, as shown.

4 Install the Air Tubing into the Inflation Valve, as shown.

8

INSTALLING THE AIR FILTER

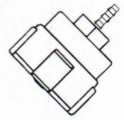

FILTER LIFE WILL VARY BASED ON ENVIRONMENTAL CONDITIONS. PROTECT THE AIR COMPRESSOR BY CHANGING THE AIR FILTER MORE FREQUENTLY IN DUSTY CONDITIONS.

1 Fully secure the Air Filter barb into the Air Tubing from the Air Compressor Kit.

2 Press Air Tubing onto the barb on the Air Compressor Air Fitting until fully seated. Assure you create a loop in the Air Tube, as shown, when securing it to the vehicle.

3 Periodically check the Air Filter during operation. When the Air Filter is dirty and needs to be replaced, contact an Authorized Firestone dealer to purchase a new one.



SECURE THE AIR FILTER IN A LOCATION THAT PROTECTS IT FROM MOISTURE AND DEBRIS, AND IS ABOVE THE LOOP IN THE AIR TUBING.

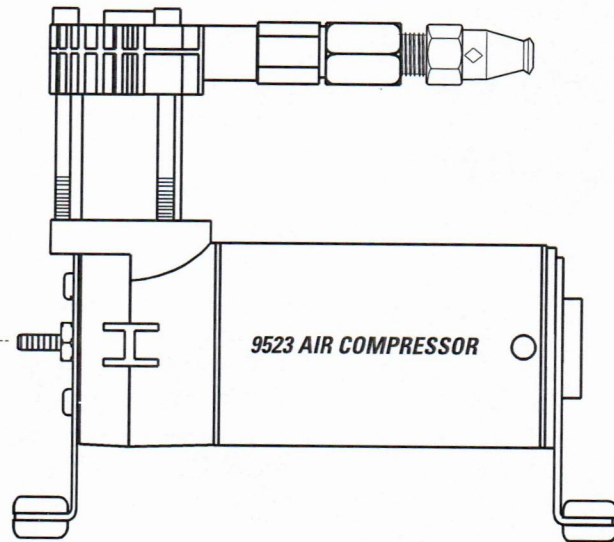
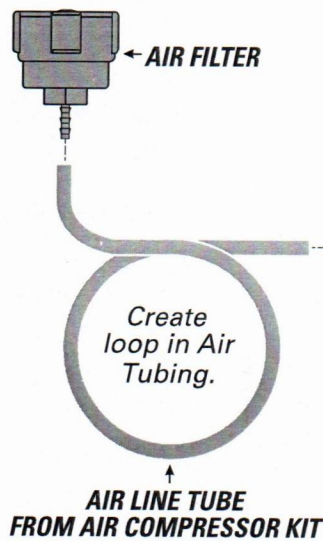

9

CLEAN UP INSTALLATION



1 Clean up the installation using supplied Nylon Ties, and return all factory parts and materials to operative state.



USING SUPPLIED NYLON TIES, SECURE ALL WIRING AND AIR LINE TUBE IN A MANNER THAT DOES NOT OBSTRUCT MOVING PARTS OR IN ANY WAY THAT AFFECTS YOUR ABILITY TO SAFELY OPERATE THE VEHICLE.

1 Download and install the Firestone Air Command app on a compatible iPhone or Android device.

2 Open the app. Once the app has established a Bluetooth connection on startup, it will automatically link to the ECU.

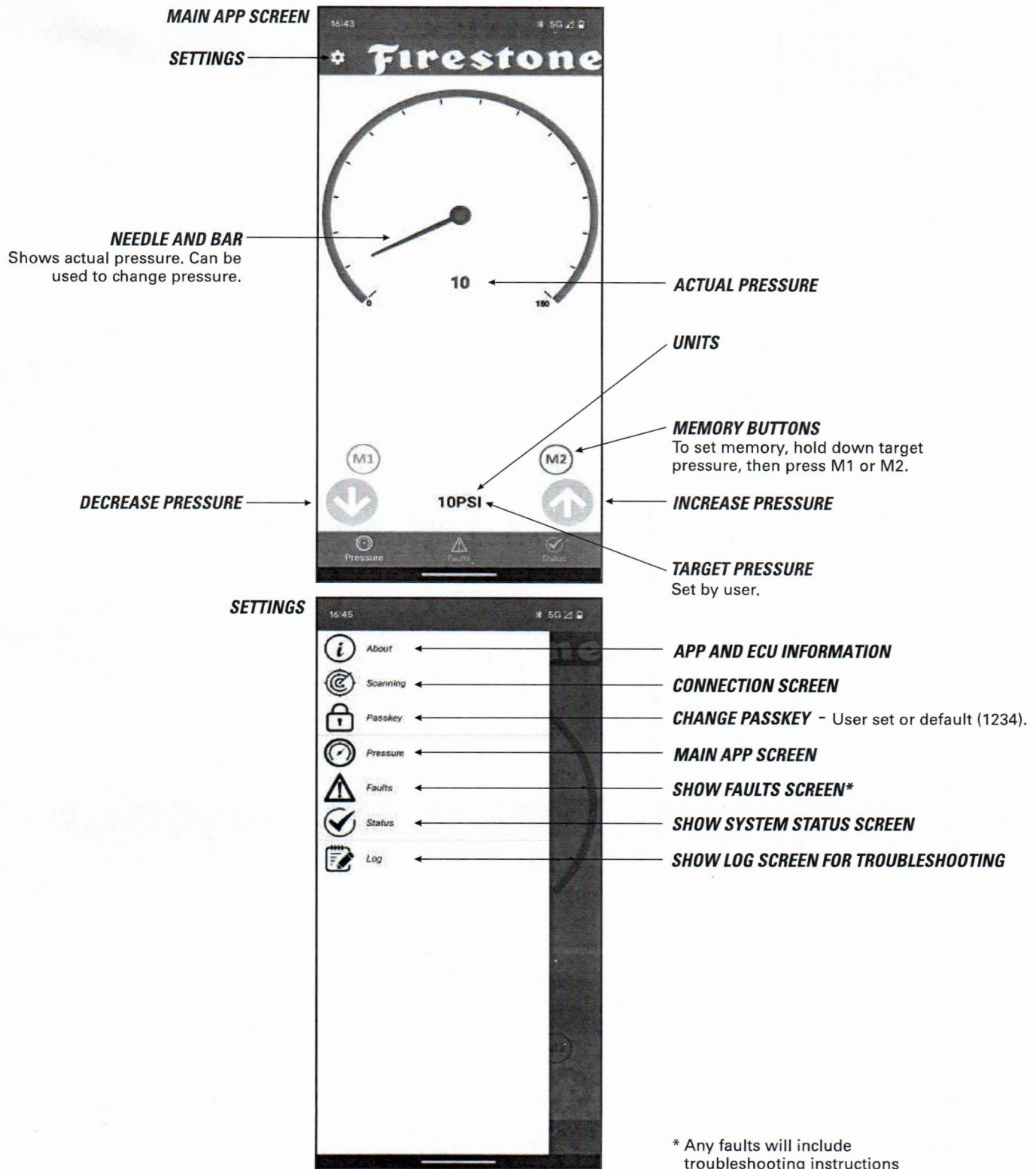

12

TEST THE SYSTEM

With the Air Command™ App and your air springs installed, you are ready to test the system.

- 1 Reattach the negative battery cable.

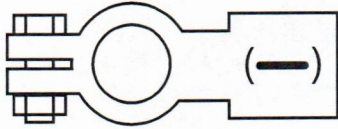

- 2 Turn on your vehicle's ignition.

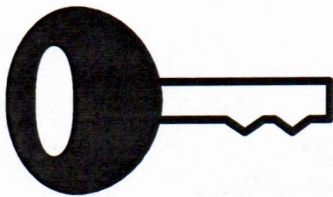

- 3 Use the Air Command™ App or Single Remote to inflate the Air Springs to 70 PSI. See Step 10 or 11 for details.

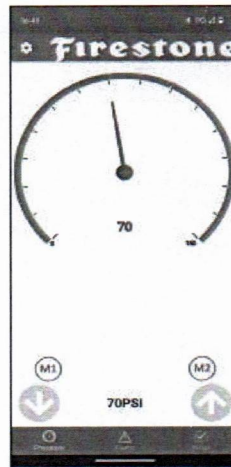

- 4 Spray fittings with soap and water mixture or glass cleaner.

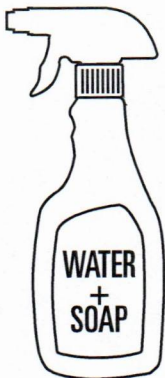

- 5 Observe bubbles.

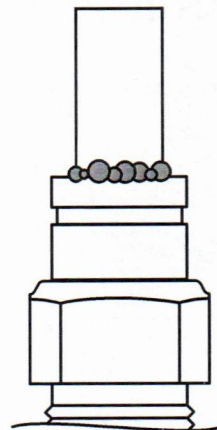

SMALL SOAP BUBBLES THAT DO NOT EXPAND

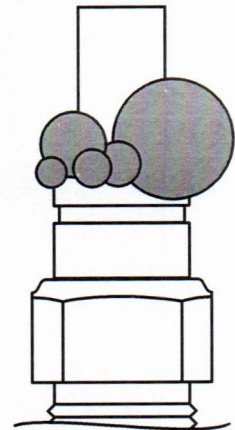

SOAP BUBBLES THAT EXPAND



NO LEAKS?

Congratulations! You're riding right with the push of a button! Remember to review the Operating Instructions.

LEAK?

Bummer. Continue to step 13 to fix the leak.



EXHAUST ALL AIR FROM THE SYSTEM PRIOR TO RELEASING AIR TUBES FROM AIR FITTINGS.



- 1 Use the Air Command™ App or Single Remote to deflate the Air Springs to 5 PSI. See Step 10 or 11 for details.

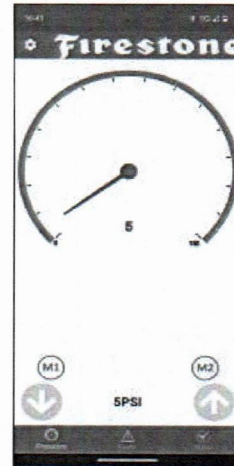

LEAK AT AIR TUBING AND AIR FITTING

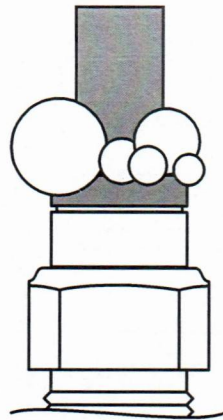

Release Air Tubing (see page 4). Review proper cuts and procedures in step 5. Repeat step 5.

LEAK AT BASE OF AIR FITTING

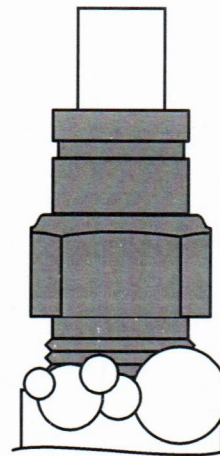

Tighten Air Fitting one turn or until leak stops.

STILL HAVE A LEAK?

Refer to the Troubleshooting section of the Instruction Manual. If the leak persists, or if there is an issue with a leaking part, email us at rrtech@fsp.com. If emailing, please include photos to help us better diagnose and understand any problems you may be experiencing.



AIRIDE

firestoneairide.com

BEFORE YOU DRIVE, CONFIRM THE FOLLOWING:

- Secure all Air Tubing and wiring.
- The system passes the leak test and holds air.
- The Air Compressor ground ring terminal is contacting bare metal, and coated with silicone if possible.
- The Wire Harness is grounded to the negative (-) battery terminal. The ECU needs a good, clean, interference-free ground.
- There is a loop in the Air Tubing as shown to prevent water or debris from getting into the Air Compressor head and damaging it.

Or, email us at rrtech@fsip.com. If emailing, please include photos to help us better diagnose and understand any problems you may be experiencing.

CONNECT WITH US



@firestoneairide



FirestoneAiride



Firestone Airide



AIRIDE

firestoneairide.com

INSTALLATION INSTRUCTIONS

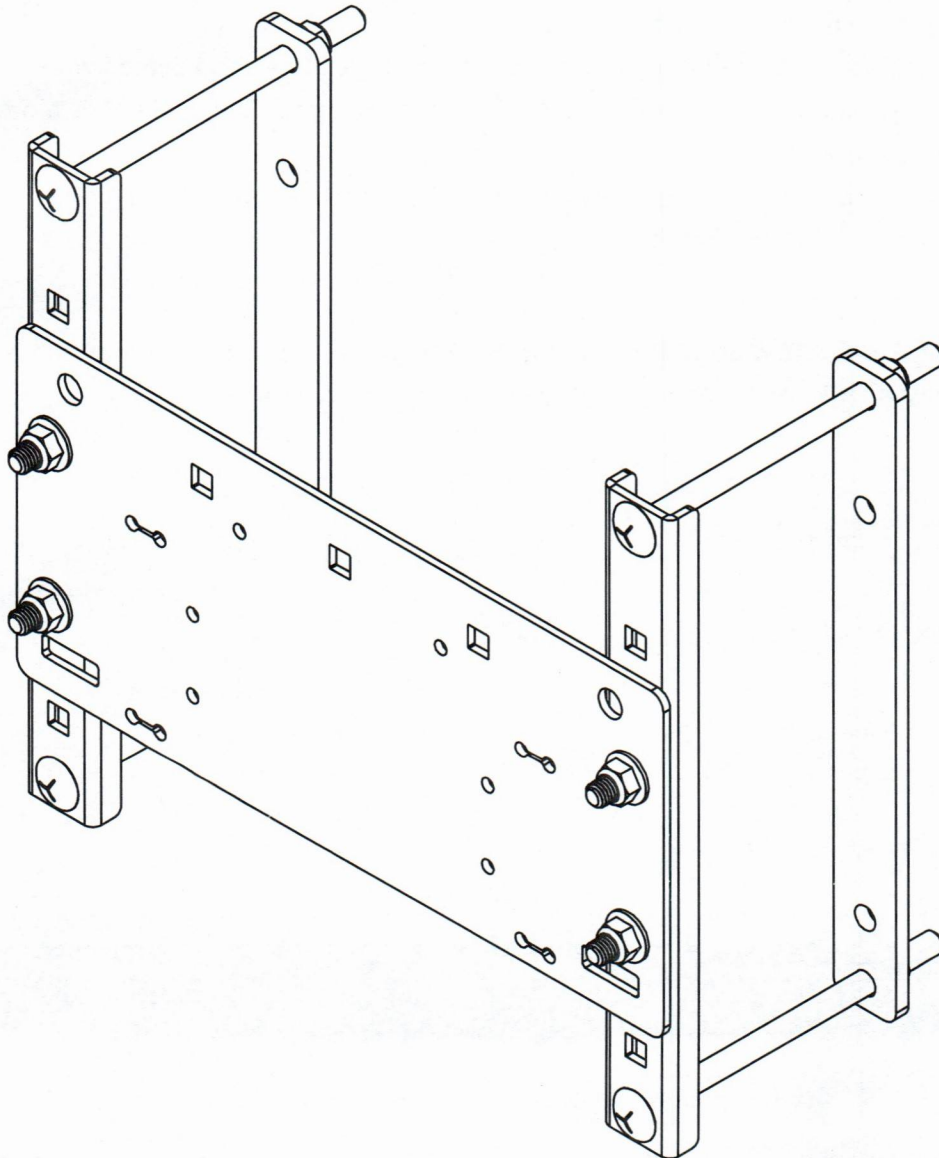

! IMPORTANT

PLEASE DON'T HURT YOURSELF, YOUR KIT OR YOUR VEHICLE. TAKE A MINUTE TO READ THIS IMPORTANT INFORMATION.

DO NOT INSTALL IF THE TRUCK HAS BEEN LIFTED AND THE STOCK JOUNCE BUMPER SPACERS ARE NOT ON THE VEHICLE. This kit is to be used on a **pickup truck only**, and **DOES NOT INCREASE YOUR VEHICLE'S MAXIMUM LOAD**.

SAFE INSTALLATION

Please take all safety precautions during installation. A hydraulic jack can fail, and if that happens, you can be seriously hurt, or worse, if you are relying on it to hold up the vehicle. If you use a hydraulic jack, secure jack stands in the appropriate locations and chock any tires still touching the ground.

Wear safety glasses or goggles. Your eyes may be lower than some parts and pieces, and you don't want to lose an eye.

Remove the possibility of any electrical issues by disconnecting the negative battery cable.

KIT USES

This kit works with Air Command Kits 2920, 2921, 2922, and 2923. Refer to the following pages for kit-specific layouts to ensure all of the components fit onto the Compressor Mount Plate.

VEHICLE GVWR

NEVER exceed the maximum load recommended by the vehicle manufacturer (GVWR). The GVWR can be found in your vehicle's owner's manual or on the data plate on the driver's side door.

INFLATING THE AIR SPRINGS

When inflating air springs, add air pressure in small quantities, checking air pressure frequently. The air springs have much less air volume than a tire, so they inflate much more quickly.



APPROPRIATE AIR PRESSURE

For best ride, use only enough air pressure in the air springs to level the vehicle when viewed from the side (front to rear). This will vary, depending on the load, location of the load, condition of the existing suspension, and personal preference.

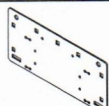
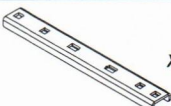

PARTS

Compare the parts below to your kit. Ensure you have all pieces, and organize them for an easier installation.

MAIN KIT CONTENTS

PT # 5694	 x 1 NO DRILL COMPRESSOR PLATE	 x 2 PLATE CHANNEL MOUNT	 x 2 BACKING PLATE
-----------	---	---	---

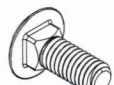
A21-760-2642 HARDWARE PACK

PT # 3067	 x 8 3/8"-16 HEX HEAD FLANGE NYLOCK NUT	 x 4 3/8"-16 X 1" CARRIAGE BOLT	 x 8 3/8"-16 X 6" CARRIAGE BOLT
-----------	--	--	--

- 1 Mount the No-Drill Compressor Plate to the Plate Channel Mounts shown below.
- 2 Align the Compressor Plate to the bottom of the slots in the Plate Channel Mount.
- 3 Select a suitable location for installation on the vehicle frame rail. Take a tape measure to get a rough height of the frame rail. Use that measurement to determine which holes to use in the mounting plates (distances between holes shown below). It is recommended to mount to the passenger side frame rail as the vehicle's battery is normally located in the engine compartment on the passenger side. Double check before final installation.

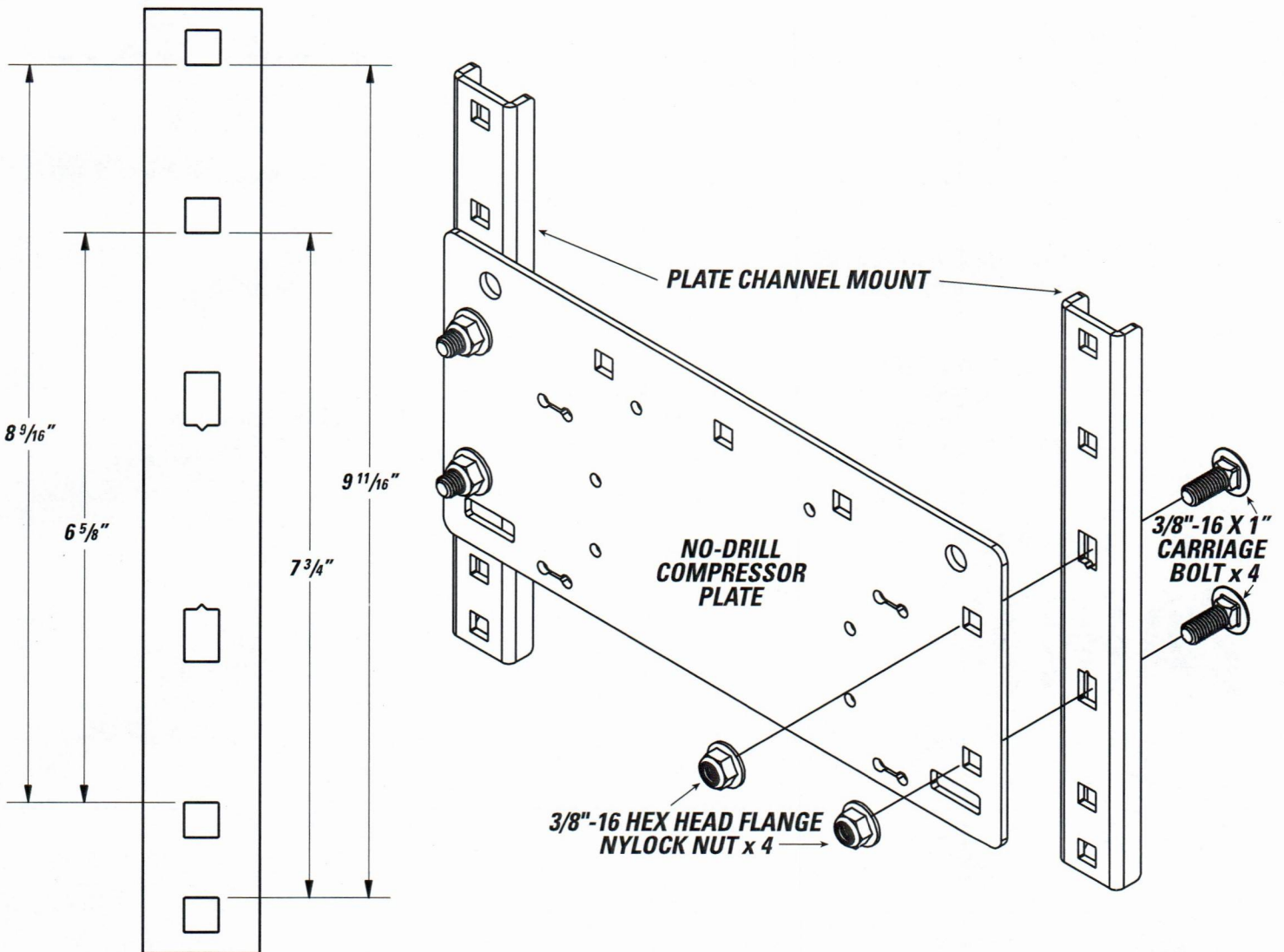

2

INSTALL THE ECU

Fasteners included in Air Command Kit



x 2



x 2



x 2



DO NOT OVER TIGHTEN MOUNTING BOLTS AND NUTS ON THE ECU. TOO MUCH TORQUE CAN CRACK THE PLASTIC FEET ON THE ECU.

1 Mount the ECU to the hole locations in the Compressor Plate using the supplied fasteners. DO NOT OVERTIGHTEN.

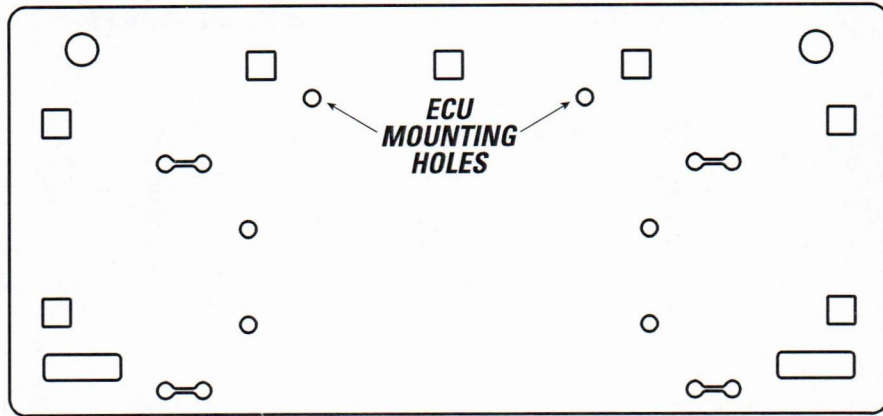
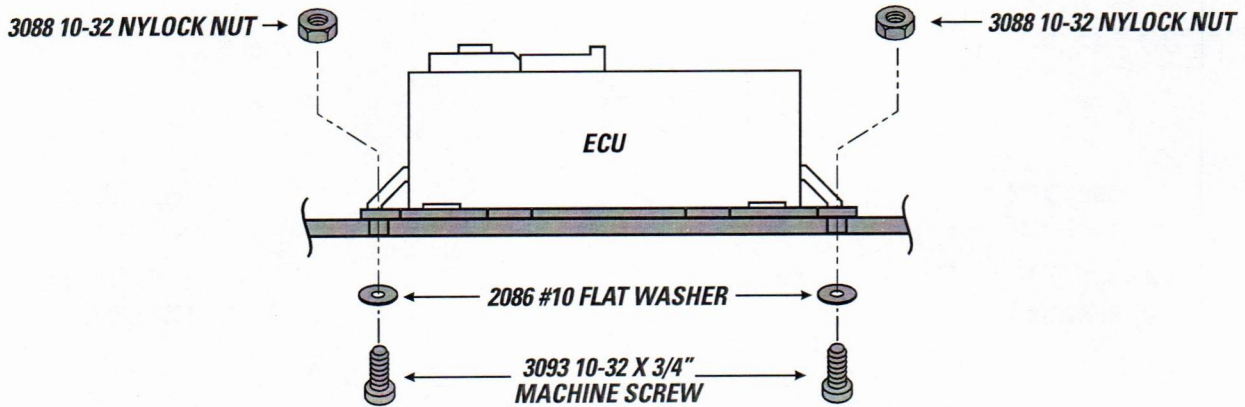

Fasteners included in Air Command Kit

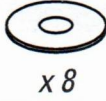

DO NOT OVER TIGHTEN MOUNTING BOLTS AND NUTS ON THE AIR COMPRESSOR. TOO MUCH TORQUE CAN CRUSH THE BRASS INSERTS AND RUBBER ISOLATORS.



1 Mount the Air Compressor to the hole locations in the Compressor Plate using the supplied fasteners. DO NOT OVERTIGHTEN.

2 It is recommended to face the outlet of the compressor towards the air springs on the rear axle of vehicle.

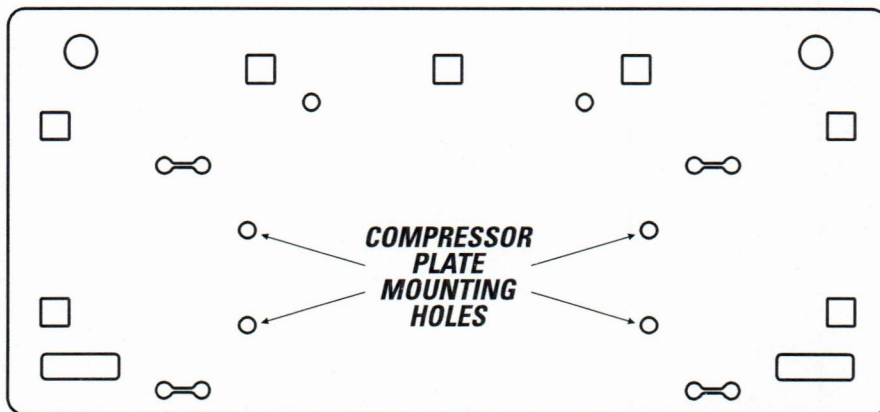
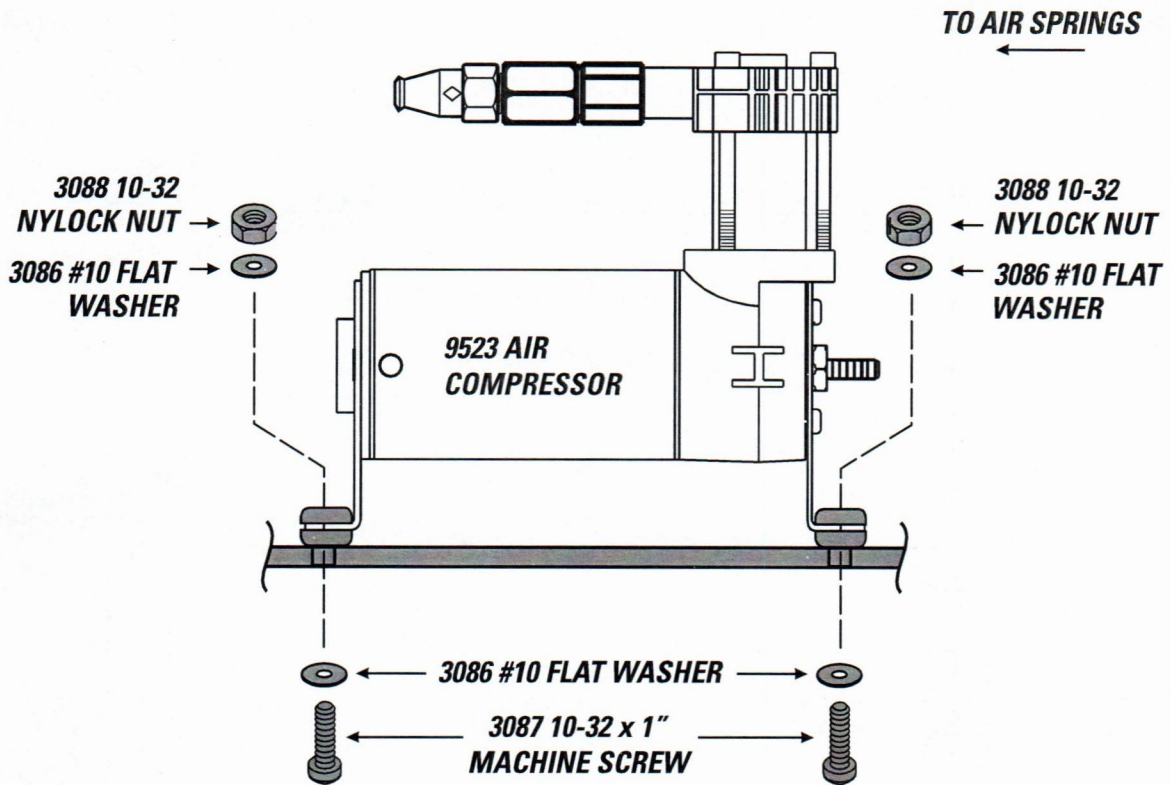

4

MOUNTING TO THE VEHICLE - USE FOR STANDARD DUTY AIR COMMAND KITS 2920 & 2922



AIR ACCESSORY MOUNTING KIT CANNOT BE USED AS A GROUNDING LOCATION FOR THE AIR COMPRESSOR

1 Install the compressor bracket assembly to the vehicles frame rail, using whichever carriage bolt holes are closest to the top and bottom of the vehicle frame as was determined in Step 1.

RECOMMENDED

2 Follow Air Command Kit instructions to run air line from the Air Compressor to the ECU.

3 Continue following the Air Command Kit instructions to connect all air tubing and electrical wiring.

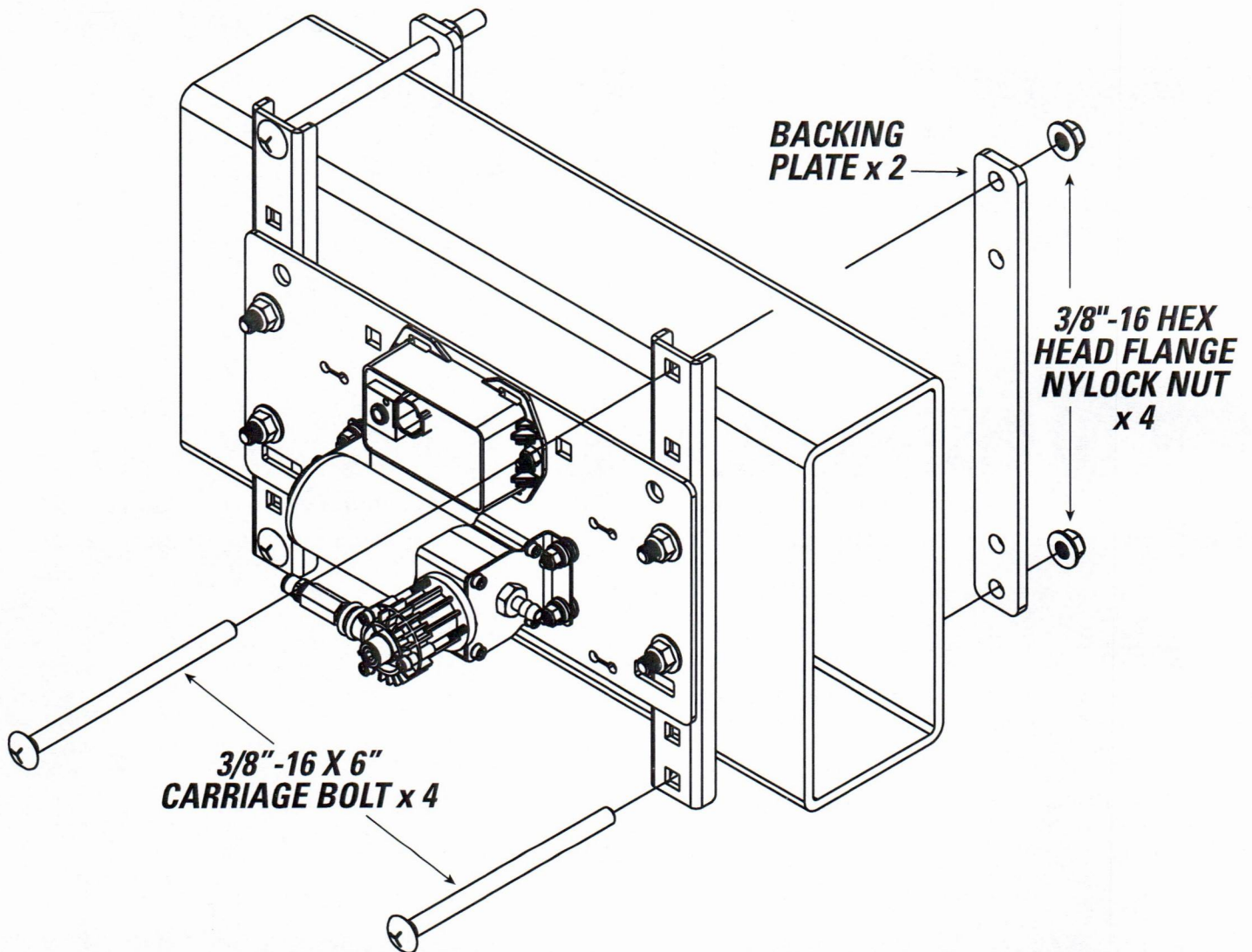



AIRIDE

firestoneairide.com

BEFORE YOU DRIVE, CONFIRM THE FOLLOWING:

- Make sure all fasteners are tight and secure.
- Make sure the installation does not interfere with any other components on the vehicle.
- Reattach negative battery cable.

NEED INSTALLATION HELP?

Email us at rrtech@fsip.com. Please include photos, kit number, and the year, make, and model of the vehicle to help us better diagnose and understand any problems you may be experiencing.

CONNECT WITH US



@firestoneairide



FirestoneAiride



Firestone Airide