

SCAN TO SEE



INSTALL VIDEO

REDROCK TC2 RUNNING BOARD

SKU #: R175556

FITS:

2009-2018 1500 Crew Cab
 2019-2024 1500 **Classic** Model Crew Cab
 2010-Up 2500 / 3500 Crew Cab



60-120 min





Cutting Not Required



Drilling May Required

Torque & Tools

Fastener Size	Tightening Torque (ft-lbs)	Wrench Required	Allen Wrench Required	
				
<input checked="" type="checkbox"/> 6mm	<input checked="" type="checkbox"/> 7-8.5		<input checked="" type="checkbox"/> 10mm	<input type="checkbox"/> 4mm
<input checked="" type="checkbox"/> 8mm	<input checked="" type="checkbox"/> 18-20		<input checked="" type="checkbox"/> 13mm	<input type="checkbox"/> 5mm
<input type="checkbox"/> 10mm	<input type="checkbox"/> 35-40		<input type="checkbox"/> 16mm	<input type="checkbox"/> 6mm
<input type="checkbox"/> 12mm	<input type="checkbox"/> 60-70		<input type="checkbox"/> 18mm	<input type="checkbox"/> 8mm

BEFORE INSTALLATION

REMOVE CONTENTS FROM BOX. VERIFY ALL PARTS ARE PRESENT. READ INSTRUCTIONS CAREFULLY BEFORE STARTING INSTALLATION. ASSISTANCE IS RECOMMENDED.

Part List

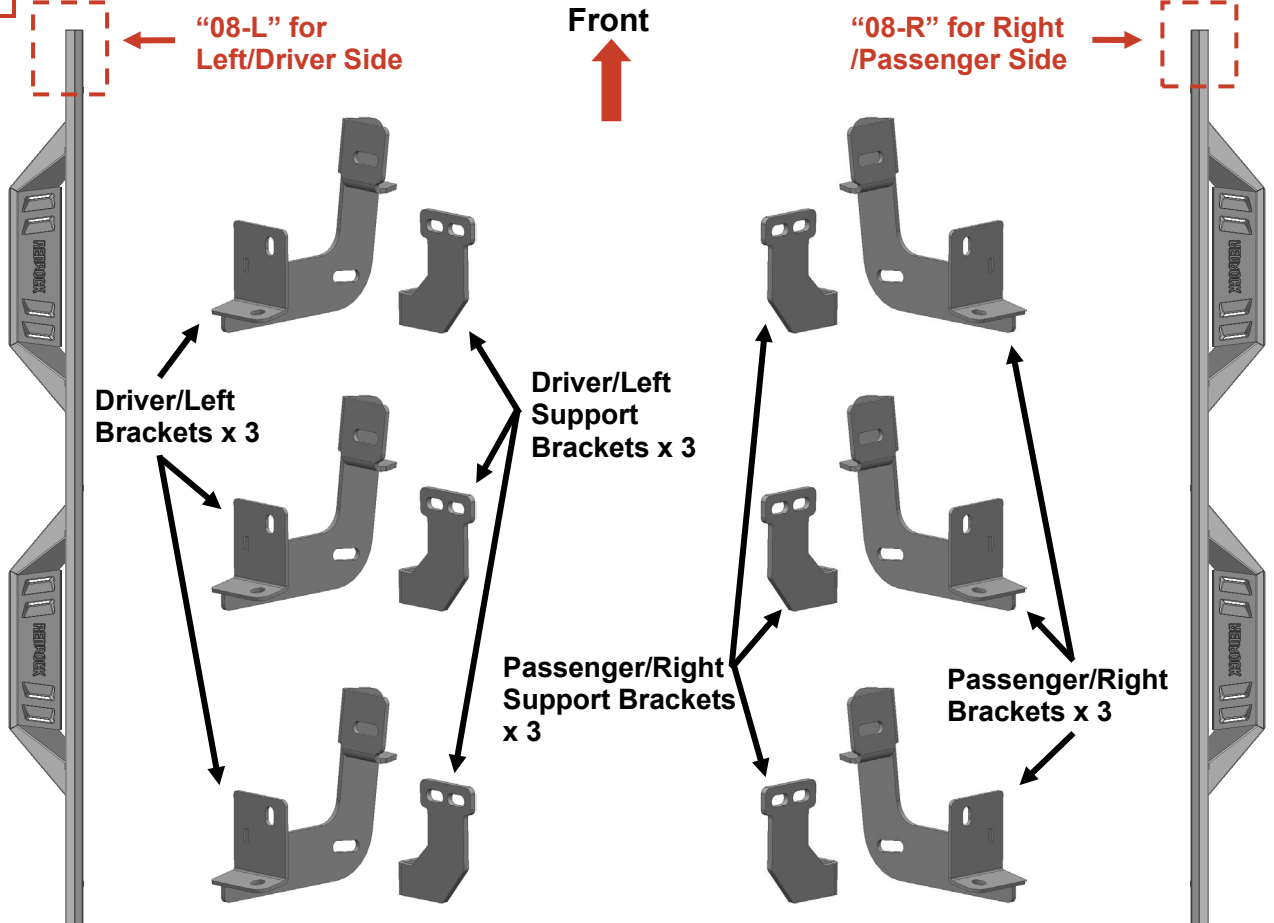

REDROCK

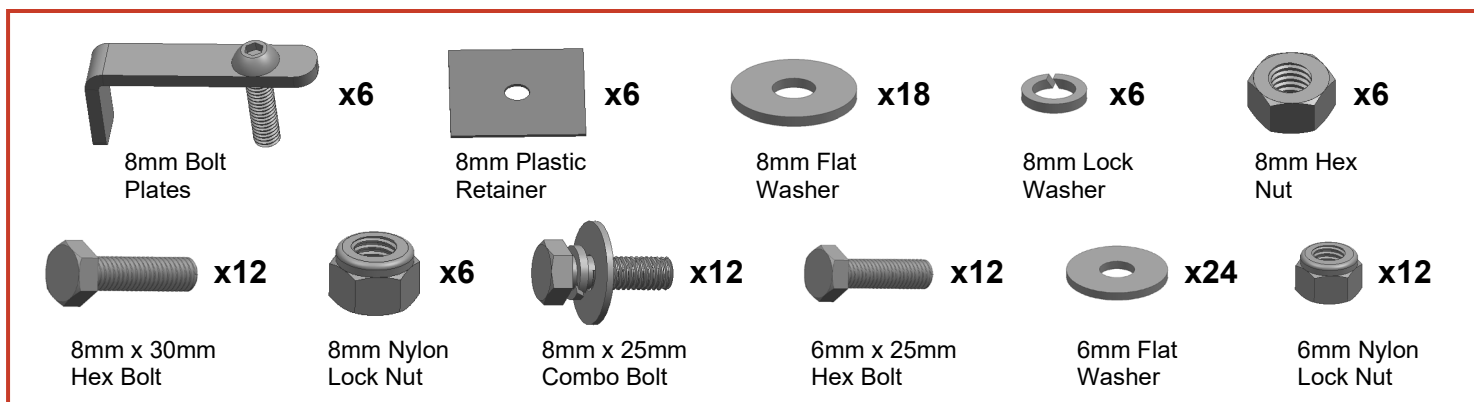

PLEASE NOTE THAT THE FOLLOWING PICTURES ARE BASED ON THE DRIVER SIDE INSTALLATION

STEP 1

Starting at the Driver/Left front side of the vehicle, remove the sealing tape covering the factory holes in the side of the inner panel, (Fig 1).

FIG 1

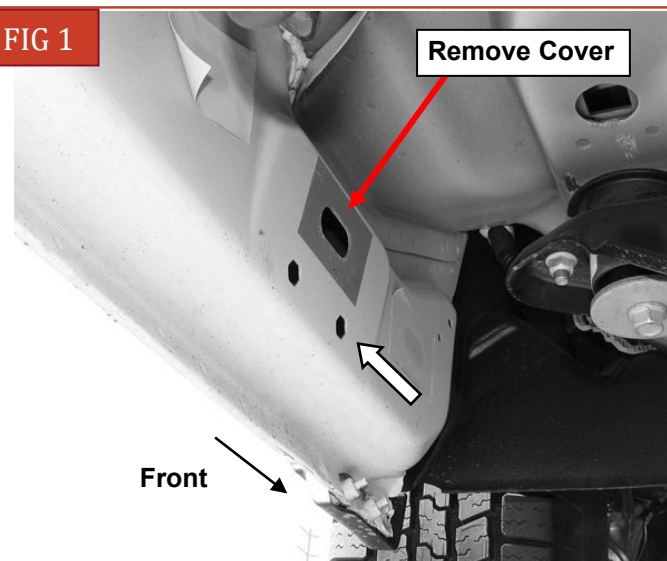

(Fig 1) 2009-mid 2015 front mounting location (No factory holes in pinch weld 2009-2012 models)

STEP 2.1

Determine the correct procedure to attach the Driver/Left side Front Bracket for your model/year:

Models without factory threaded inserts in body panel:

- Select (1) 8mm Bolt Plate. Insert the threads of the Bolt Plate into the large hole and out the **Front** hex shaped hole in the rocker panel, (Fig 2).
- Thread (1) 8mm Plastic Retainer onto the threaded end and down tight against the body panel, (Fig 2). **NOTE:** The Plastic Retainer is designed to keep the Bolt Plate from falling into the body panel and to aid in Bracket installation.

FIG 2

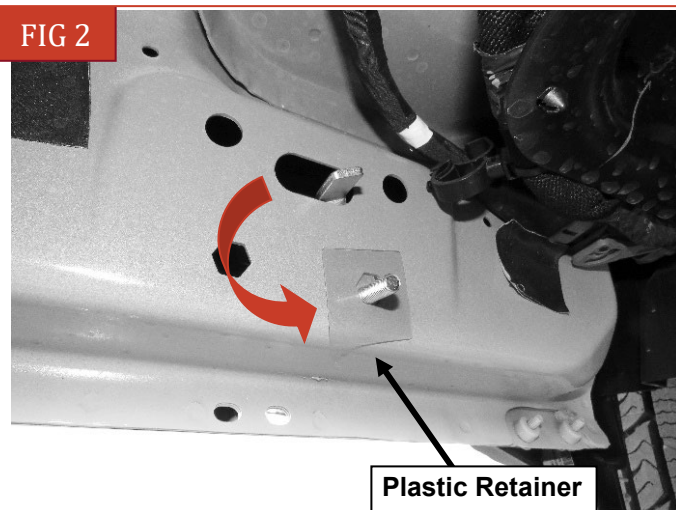

(Fig 2) Insert (1) 8mm Bolt Plate into the upper slot and line the threaded bolt up to the front hex hole, Thread (1) 8mm Plastic Retainer over the threads to hold it in place

REDROCK

- c. Select (1) Driver/Left Mounting Bracket. Attach the Bracket to the threads on the Bolt Plate with (1) 8mm Flat Washer, (1) 8mm Lock Washer and (1) 8mm Hex Nut, (**Fig 3**). Do not tighten hardware

FIG 3

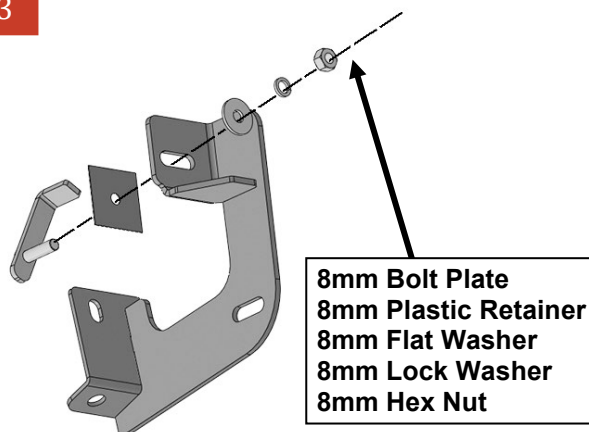

(Fig 3) Attach Driver/Left Bracket to 8mm Bolt Plate

STEP 2.2

Models with factory threaded inserts in body panel (Fig 4):

- a. Attach (1) Driver/Left Mounting Bracket to the rear threaded hole with (1) 8mm x 30mm Hex Bolts, (1) 8mm Lock Washers and (1) 8mm Flat Washers, (**Fig 5**). Do not tighten hardware.

FIG 4

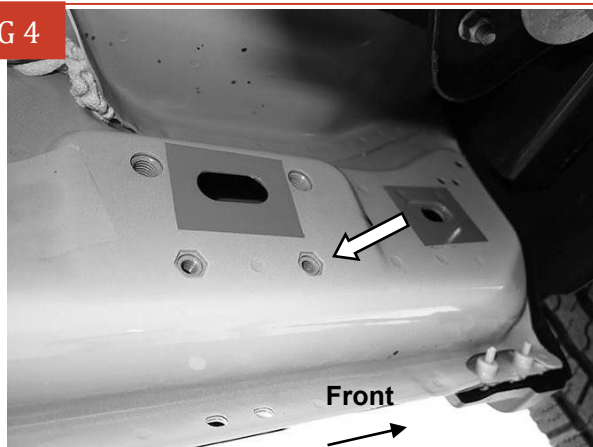

(Fig 4) Driver/Left side front mid 2015-on (example of models with factory installed threaded inserts)

FIG 5

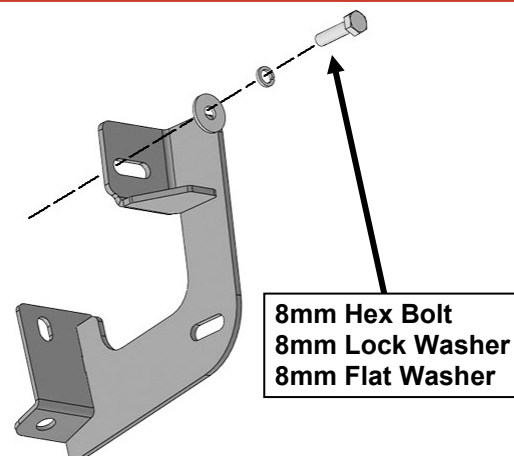

(Fig 5) Attach Driver/Left Mounting Bracket to factory installed threaded inserts

STEP 3

Next, select (1) Driver/Left Support Bracket. Attach the Bracket to the back of the pinch weld with (2) 6mm Button Head Bolts, (4) 6mm Flat Washers and (2) 6mm Nylon Lock Nuts, (**Fig 6**). Do not tighten hardware. **IMPORTANT: 2009-12 models not equipped with factory holes will require drilling through the pinch weld to fully attach Bracket.** Do not drill through pinch weld at this time. (See Step 7).

FIG 6

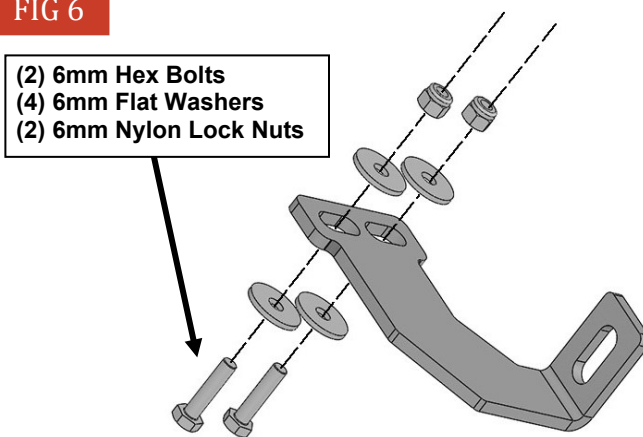

(Fig 6) Attach (1) Driver/Left Support Bracket to the pinch trim

REDROCK

Attention

2009-2012 models without holes in pinch weld will require drilling 1/4" holes through pinch weld to attach the bracket.

Do not drill too closely to the edge of the pinch trim or damage to the vehicle may result.

Do complete installation of Running Boards first, level Running Board before drilling holes for bracket.

FIG 8



(Fig 8) Driver/Left Mounting Bracket and Support Bracket attached to the Front Mounting Location.

STEP 4

Attach the Support Bracket to the Mounting Bracket with (1) 8mm x 30mm Hex Bolt, (2) 8mm flat Washers and (1) 8mm Nylon Lock Nut, (Figs 7 & 8). Do not tighten hardware.

FIG 7

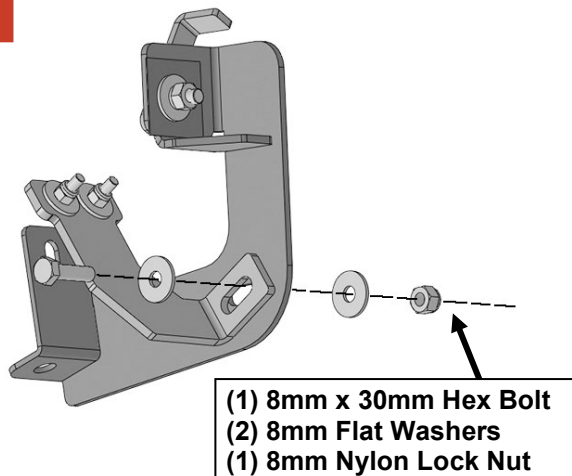

(Fig 7) Attach the Support Bracket to the Mounting Bracket

STEP 5

Move along the side of the body panel to the center and rear mounting location. Repeat **Steps 2—4** to attach the remaining (2) Driver/Left Mounting Brackets and (2) Driver/Left Support Brackets to the Driver/Left center and rear mounting location, (Figs 9 & 10).

FIG 9

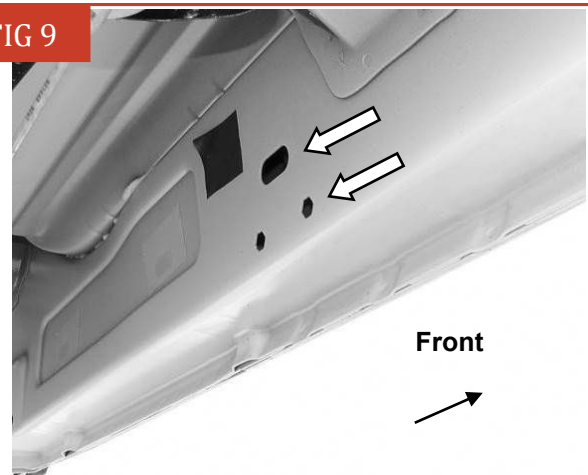

(Fig 9) Driver/left side center mounting location

REDROCK

FIG 10

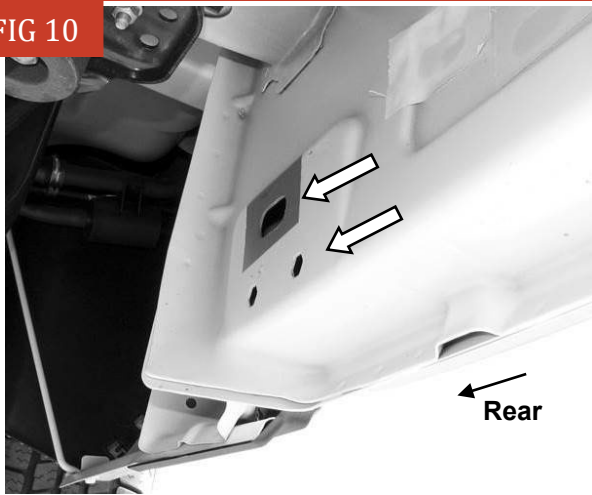

(Fig 10) Driver/left side rear mounting location

STEP 6

Select the Driver/Left Running Board. **NOTE:** The Driver/Left Running Board will have a “08-L” on the front of the Running Board. Attach the Running Board to the (3) Mounting Brackets with (6) 8mm Combo Bolts, (Fig 11). Do not tighten hardware.

FIG 11

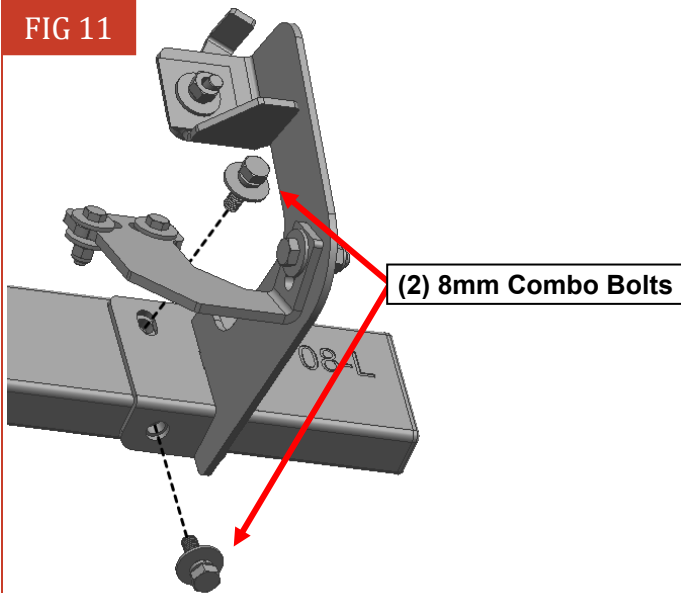

(Fig 11) Attach the Driver/left Running Board to the Mounting Brackets

STEP 7

Properly level and adjust the Side Step and fully tighten all hardware.

2009-12 models requiring drilling to attach Brackets to pinch weld:

- Level the Running Board to the vehicle. Make sure all (3) Brackets are tight against the bottom of the body panel and tighten all mounting hardware.
- Mark the location of the slots onto the pinch weld.
- Temporarily remove the Running Board and the (3) Support Brackets. Drill (2) 1/4” holes through the pinch weld for each Bracket.
IMPORTANT: Do not drill too close to the bottom edge of the pinch weld. Drill the holes in the center of the marked slots.
- Repeat **Step 3** to attach the Brackets to the drilled holes in the pinch weld. Check for level then fully tighten all hardware.

STEP 8

Repeat **Steps 1—7** to attach the Passenger/Right Running Board.

STEP 9

Do periodic inspections to the installation to make sure that all hardware is secure and tight.

Attention

To protect your investment, do not use any type of polish or wax that may contain abrasives that could damage the finish.

Mild soap may be used also to clean the Running Boards.