

BAKflip

BEST-SELLING HARD FOLDING COVER

G2 VP HD F1 FIBER MAX MX4

RAM BOX INSTALLATION SHEET

Any damaged or missing parts?

Parts will be shipped to you directly. Call 844-779-8986



RAM BOX HARDWARE

- Front cover mounting plate (left & right)
- Prop rod swivel mounting bracket
- Prop rod to lock cover open
- Prop rod retainer clip
- Cover latching plate
- Track mounting bracket
- Front drain cup (left & right)
- Rear tailgate drain cap (left & right)
- Adhesive promoter packet (*not shown*)
- Bulkhead seal (*not shown*)
- Rail seals (*not shown*)

6.5' bed

5.5' bed

Front (cab)

Rear (tailgate)

1 HARDWARE BAG

- 2 x Elevator bolt (w-large flat head)
- 4 x Rubber washers
- 2 x Large flat washers
- 2 x Lock washers
- 2 x Star knobs (thumb screws)
- 2 x Buckle ends
- 4 x Machine screws
- 4 x Threaded posts

PARTS INCLUDED IN YOUR KIT

- 1 x Hard folding cover assembly
- 3 x D Shaped cab bumpers (taped to cover)
- 1 x Bulkhead seal (¾ x ¾ x truck width)
- 2 x Black drain tubes

1

Install the provided cab/bulkhead seal (weather strip). Wipe surface with isopropyl alcohol and let flash dry before applying tape.

2

Unclip and remove plug from rail.

3

Remove tie downs from rail. Don't worry they will be re-installed later.

4

Apply provided adhesive promoter (wipes) to top edge of the aluminum rail and tape seal to top inner edge, the rubber has a bump that goes to the inside.

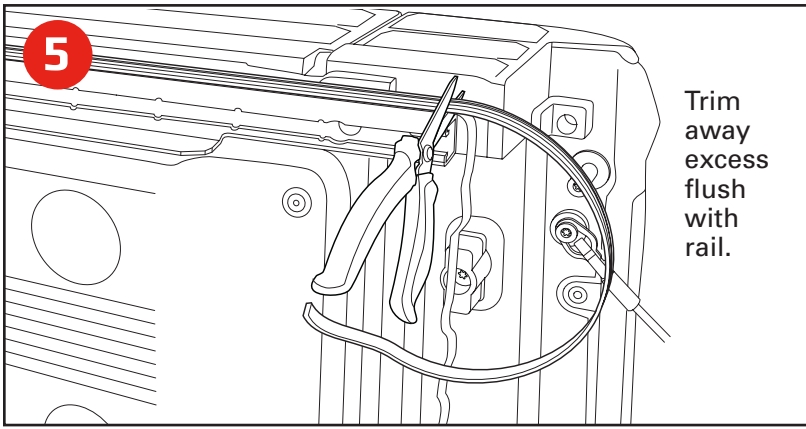

5

Trim away excess flush with rail.

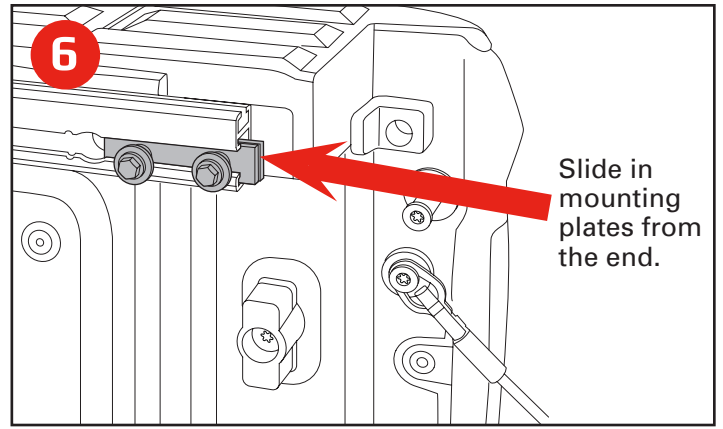

6

Slide in mounting plates from the end.

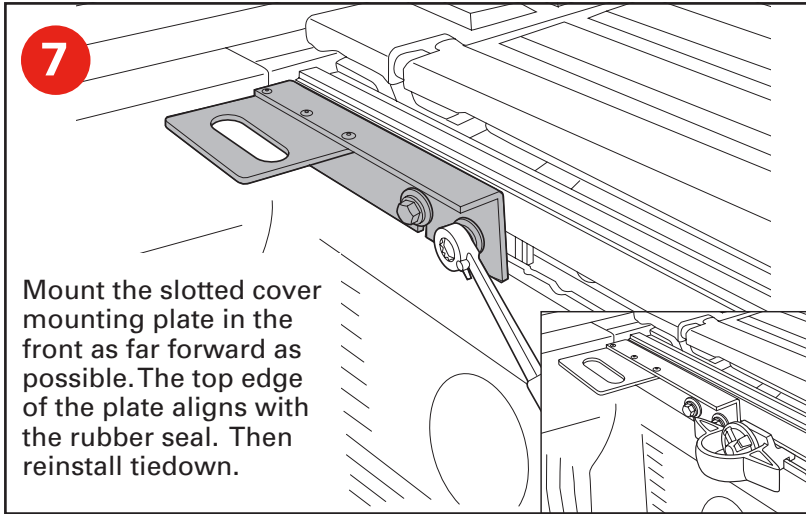

7

Mount the slotted cover mounting plate in the front as far forward as possible. The top edge of the plate aligns with the rubber seal. Then reinstall tiedown.

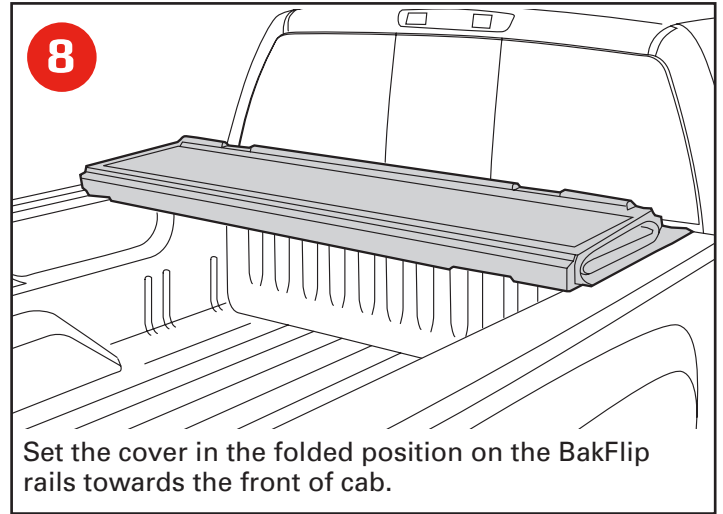

8

Set the cover in the folded position on the BakFlip rails towards the front of cab.

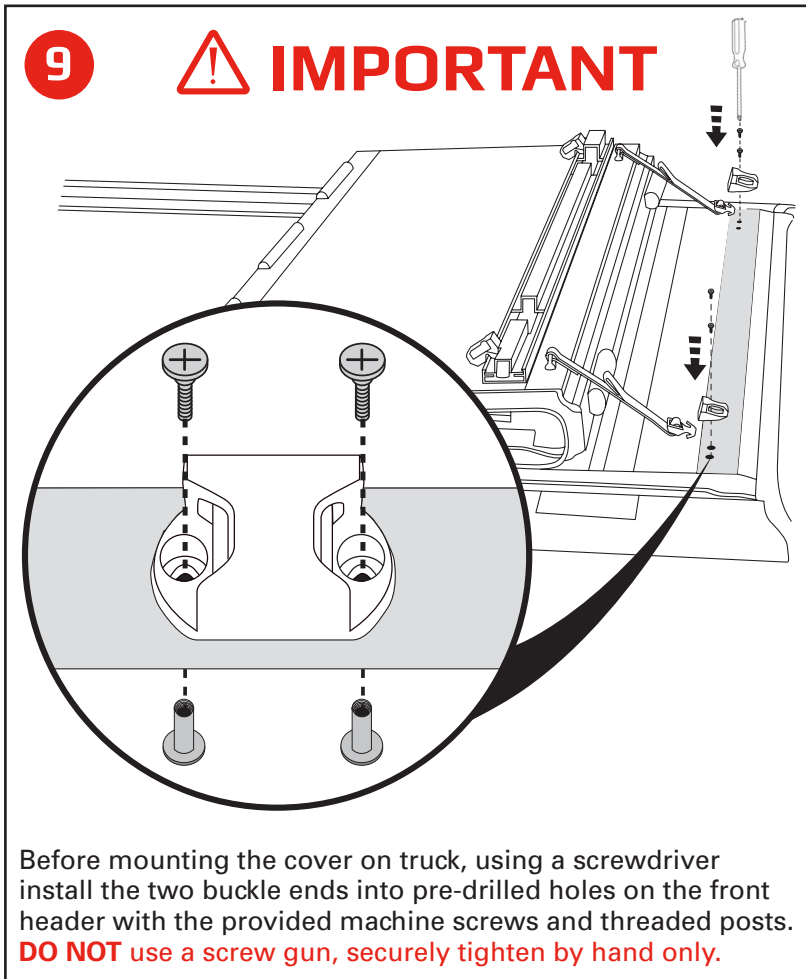

9

IMPORTANT

Before mounting the cover on truck, using a screwdriver install the two buckle ends into pre-drilled holes on the front header with the provided machine screws and threaded posts. **DO NOT** use a screw gun, securely tighten by hand only.

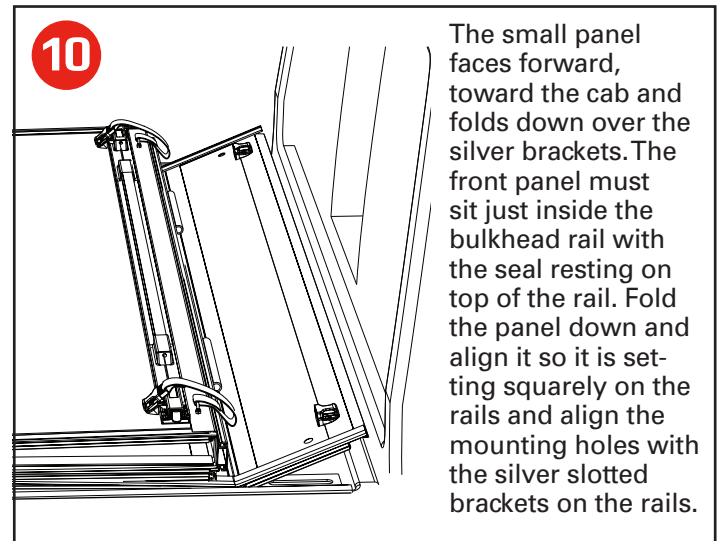

10

The small panel faces forward, toward the cab and folds down over the silver brackets. The front panel must sit just inside the bulkhead rail with the seal resting on top of the rail. Fold the panel down and align it so it is setting squarely on the rails and align the mounting holes with the silver slotted brackets on the rails.

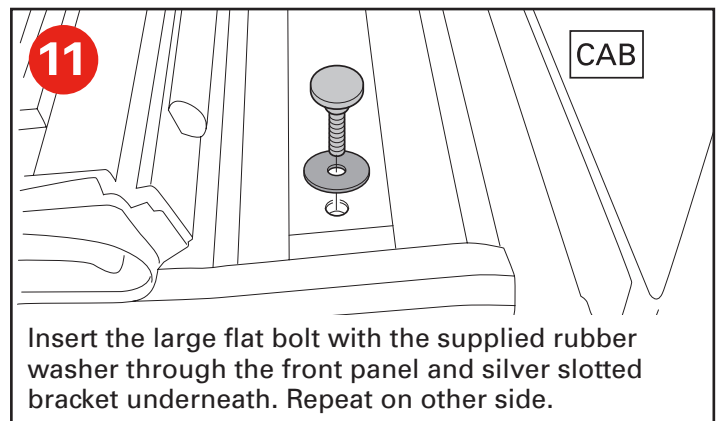

11

CAB

Insert the large flat bolt with the supplied rubber washer through the front panel and silver slotted bracket underneath. Repeat on other side.

12

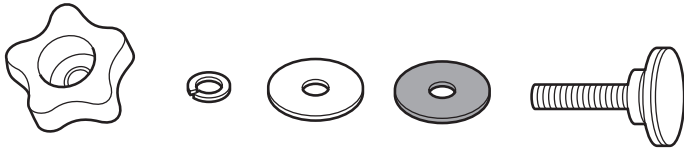

The large flat bolt goes down through the front panel on each side. Underneath the cover, the order of washers is as follows: rubber washer first, then large flat stainless washer, then the lock washer, and finally the 5 star finger knob as shown to the left.

13

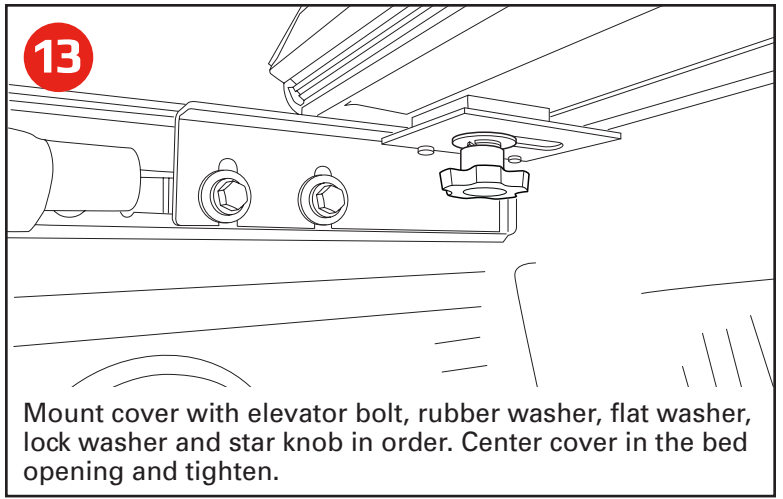

Mount cover with elevator bolt, rubber washer, flat washer, lock washer and star knob in order. Center cover in the bed opening and tighten.

14

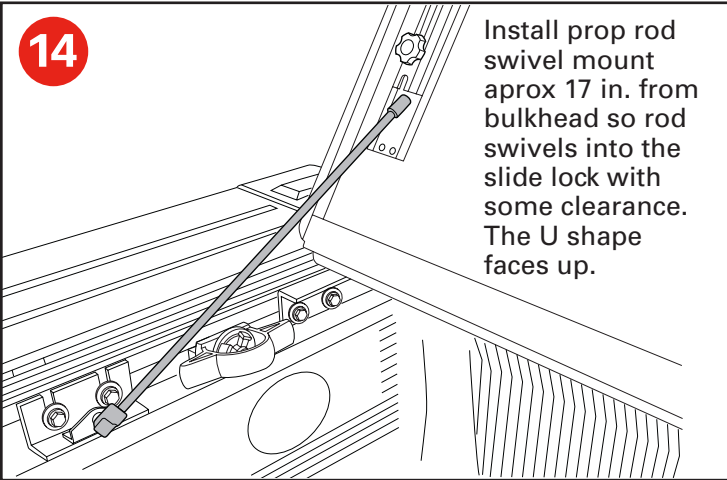

Install prop rod swivel mount approx 17 in. from bulkhead so rod swivels into the slide lock with some clearance. The U shape faces up.

15

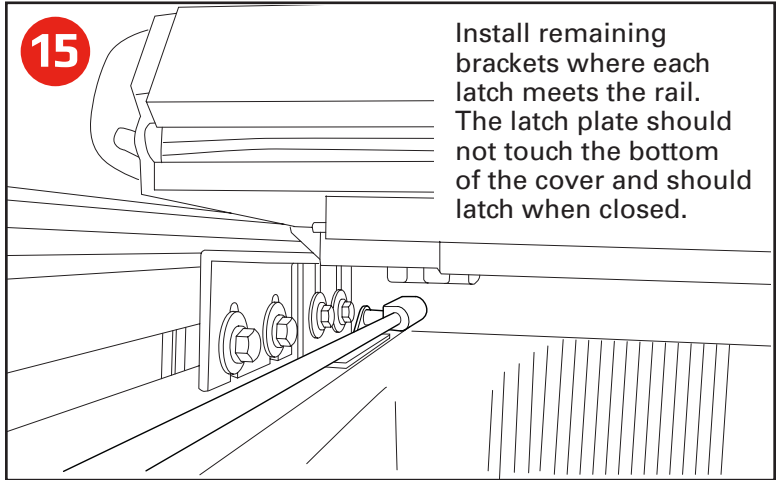

Install remaining brackets where each latch meets the rail. The latch plate should not touch the bottom of the cover and should latch when closed.

16

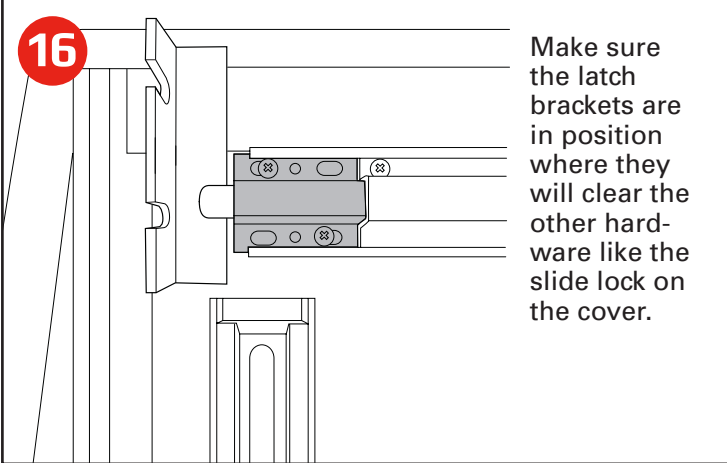

Make sure the latch brackets are in position where they will clear the other hardware like the slide lock on the cover.

17

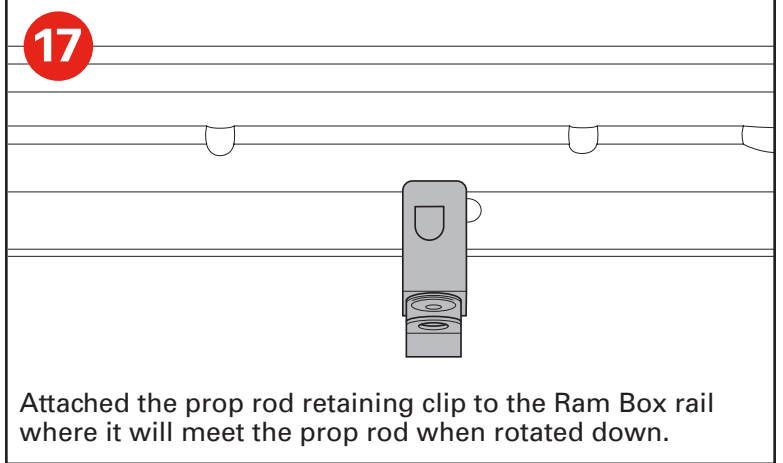

Attached the prop rod retaining clip to the Ram Box rail where it will meet the prop rod when rotated down.

18

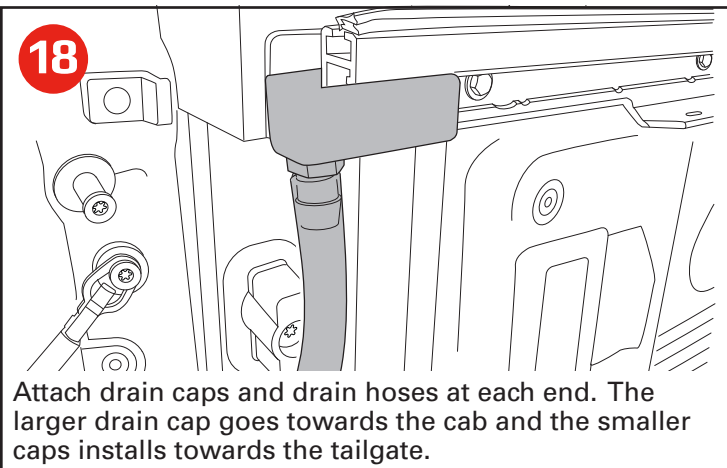

Attach drain caps and drain hoses at each end. The larger drain cap goes towards the cab and the smaller caps installs towards the tailgate.

19

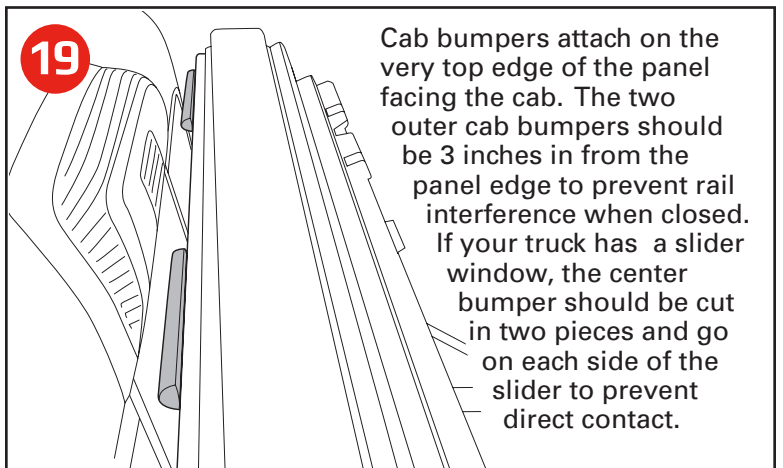

Cab bumpers attach on the very top edge of the panel facing the cab. The two outer cab bumpers should be 3 inches in from the panel edge to prevent rail interference when closed. If your truck has a slider window, the center bumper should be cut in two pieces and go on each side of the slider to prevent direct contact.

IMPORTANT

BAKFlip safe operation and use

IMPORTANT NOTICE

While driving, cover must be completely flat and secure with all latches in the closed position OR completely folded up (all panels) and secured at the cab. **DO NOT DRIVE** with cover partially opened.

Tonneau Cover Positions While Operating Vehicle

Prior to vehicle operation, tonneau cover MUST be properly secured.

CLOSED POSITION

All panels must be closed and **FULLY LATCHED** to tonneau side rail. All panels must be flat and latches engaged

FOLDED UP POSITION

To drive with your cover in the folded up position, simply make use of the tie down straps and buckles provided with your cover. Ensure **BOTH** buckle clips are fully inserted into the buckle ends located on the front header panel of the cover and adjust the straps to ensure the cover is secure during vehicle operation. The clips should be secured in the storage position, as shown in Figure 1, when not in use.

FLIPPED UP POSITION

A) Fold the cover open and lift it until its vertical or past 90 degrees towards your truck cab. Then release the prop rod that is attached to your rail. Fold the prop rod over and position it firmly against the vertical plate on the underside of your cover. Then slide the prop rod locks downwards and tighten the knobs to lock into position. Do this on both sides of the cover.

B) Your cover should be firmly in position with little to no movement once the prop rods are locked.

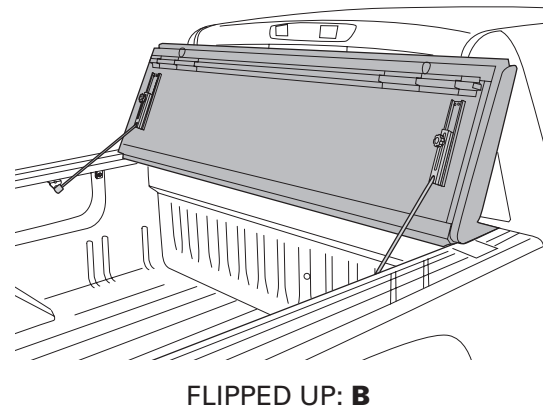
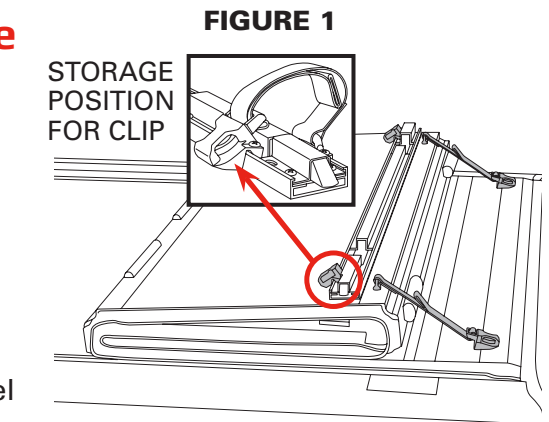
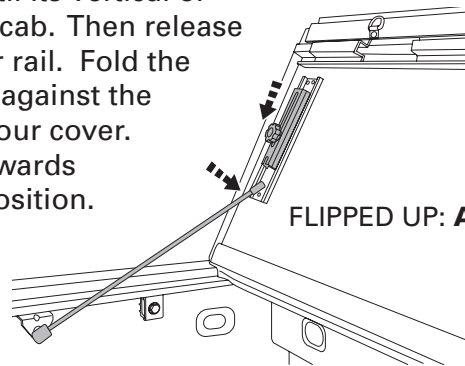

Tail Panel Operation

TO CLOSE THE TAILGATE PANEL

■ **WARNING** – to avoid damage, always shut tailgate before closing cover. **DO NOT** shut your tailgate when the rear panel of your cover is closed.

TO RAISE THE TAILGATE PANEL

- Open the tailgate and reach under the panel for the cable at the ends of the panel housing.
- Pull down on either cable to release both rear latches with one hand while lifting the panel with the other hand.

EXCEPTION - BAKFlip MX4 offer's a universal tailgate seal which allows the tailgate to close with the cover up or down.

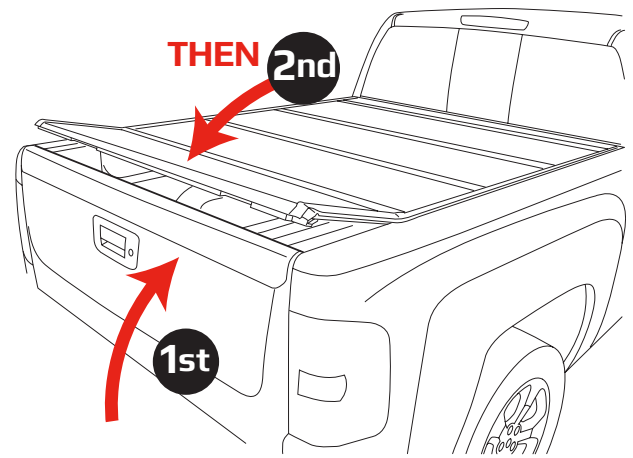

DO NOT ATTEMPT TO DRIVE WITH THE TAIL PANEL IN THE PARTIALLY OPEN POSITION!

Additional Important Operating Tips

- Tonneau cover **MUST** be free of foreign material including snow and ice before opening panels.
- Do **NOT** tow your vehicle from the rear with the tonneau on your truck.
- Do **NOT** operate vehicle with objects on top of cover.

FAILURE TO FOLLOW THESE CAUTIONS MAY RESULT IN SEVERE DAMAGE AND WILL VOID YOUR WARRANTY!



Remove any snow or foreign matter before folding cover.



Do **NOT** tow your vehicle from the rear with this cover on your truck.

Warranty

BAK® Industries ("BAK") warrants your BAKFlip Hard Folding Cover to be structurally free from defects in material and workmanship for the period as outlined in the table below from the retail date of purchase. Warranty registration must be on file and/or proof of original purchase (detailed and dated receipt) required for warranty service. Warranty is non-transferable and applies to the original purchaser of the BAK product only.

PRODUCT	WARRANTY PERIOD	REGISTER YOUR WARRANTY NOW AT BAKINDUSTRIES.COM
BAKFlip VP	1 Year Limited Warranty	
BAKFlip G2	2 Year Limited Warranty	
BAKFlip MX4	3 Year Limited Warranty	
BAKFlip HD	2 Year Limited Warranty	
BAKFlip FiberMax	2 Year Limited Warranty	
BAKFlip F1	3 Year Limited Warranty	

BAK reserves the right to determine whether a product needs to be repaired or replaced. No labor or service allowance is given or implied. The warranty will be void if the product has been damaged by accident, unreasonable use, neglect, improper service/installation/removal, modifications, acts of God or normal wear and tear or other causes not arising out of defective materials or workmanship. BAK assumes no liability for injury, loss, incidental or consequential damages. BAK reserves the right to substitute an entire replacement system or provide other remedies than those listed in this warranty for discontinued products or other reasons. Shipping charges will apply for any repair or replacement.

BAK is committed to providing you with our best service at all times. Please feel free to contact us should you require any assistance with your BAK product.

CARE AND MAINTENANCE

BAK Flip tonneaus are made from durable materials and require simple care to ensure a long life of performing well and looking great.

BAK Flip G2, HD, MX4, Fibermax & F1

Cleaning the Top (Washing)

Standard automotive soap and water with a soft sponge or cloth is recommended for cleaning. Shammy dry to keep the finish polished and brilliant. Wax is NOT recommended as it tends to fill in cracks and crevices, which may affect the textured panel finish. Do NOT use any harsh cleaners or abrasives.

BAKFlip VP

Cleaning the Top (Washing)

These stylish covers incorporate OE marine grade vinyl laminated on the top surfaces. Standard automotive soap and water used with a soft sponge or cloth is recommended for cleaning. Shammy dry to prevent water spots and ensure a rich dark finish.

Treating the Vinyl Top

3M 303 Aerospace Protectant may be used to keep the vinyl surface clean and protected from the elements and will also remove any water spots that may have developed. 303 Aerospace not only protects against fading, discoloration and cracking from harmful UV rays, but repels dust and stains. Simply spray on and wipe dry for a beautiful, matte finish that protects your cover from road grime and dust.

All BAKFlip

Maintenance

It is recommended that you periodically check your cover is securely attached to your truck bed. Inspect the clamps and front mounting bolts to ensure they were properly installed and have not come loose or knocked out of adjustment during operation. Covers that are used with high frequency or that are subject to the vibrations and impact from rough roadways can cause the cover to require adjustment.

Lubricating the Latches

It is recommended that you periodically inspect and service the latches on each panel. Clean away any excess dirt or grime and lubricate with silicone spray. Ensure the latches move freely in and out to properly engage the side rail and provide proper performance with optimum security. Be careful not to overspray the cover. Wipe away any excess around the latch location.