

MOMENTUM **HD**

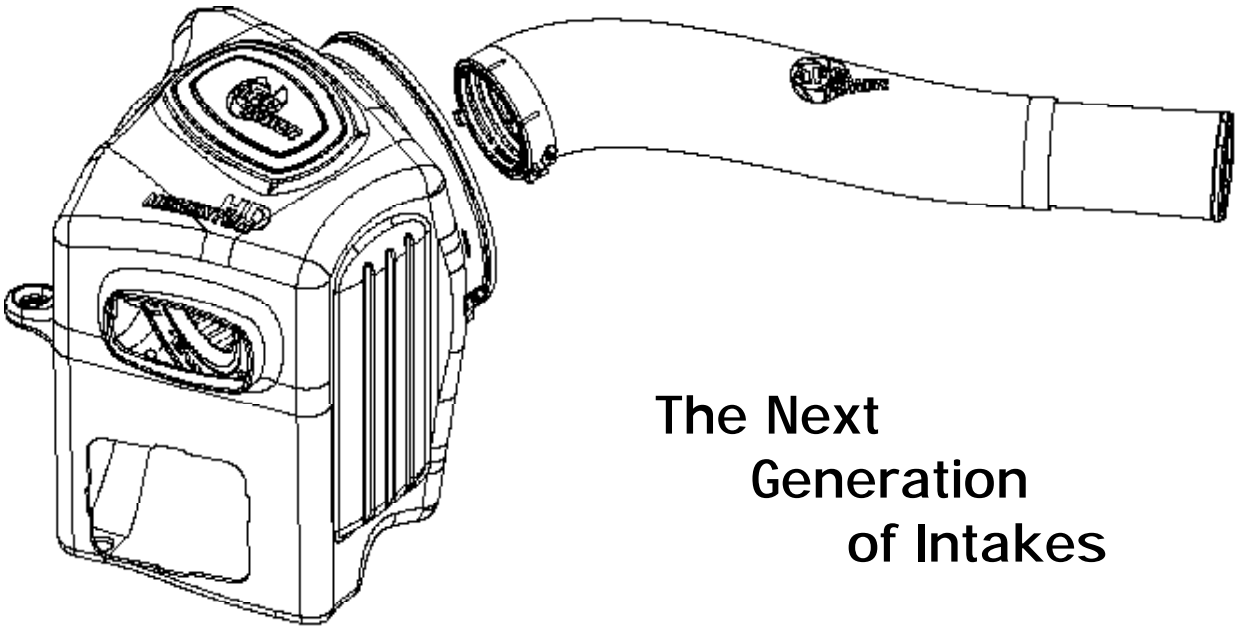

The Next
Generation
of Intakes

advanced FLOW engineering

Instruction Manual P/N: 51-72006-E

Make: **RAM** Model: **1500 EcoDiesel** Year: **2014-2019** Engine: **V6-3.0L (td)**



- Please read the entire instruction manual before proceeding.
- Ensure all components listed are present.
- If you are missing any of the components, call customer support at 951-493-7185.
- Ensure you have all necessary tools before proceeding.
- Do not attempt to work on your vehicle when the engine is hot.
- Disconnect the negative battery terminal before proceeding.
- Retain factory parts for future use.

Label	Qty.	Description	Part Number
A	1	Air Filter (Pro DRY S)	21-91100
B	1	Tube	05-72006B1
C	1	Housing	05-72006B2-A
D	1	Clamp, T-Bolt (8-5/16" - 8-5/8")	03-50267
E	1	Coupling, Adaptor	05-01345
F	1	Clamp, #060	03-50002
G	1	Plug, Urethane	05-01202
H	1	12oz. Cleaner Spray	90-10011

Tools needed: Torx T20 driver, 1/4" Drive Socket Wrench, 8mm Shallow Socket, 10mm Deep Socket, 11mm Deep Socket
 Recommended: Acetone, WD-40, Hairspray (Aqua Net)

NOTE: OE air scoop and MAF cartridge are not included with this kit.

Note: Legal in California for use on race vehicles only. The use of this device on vehicles used on public streets or highways is strictly prohibited in California and others states that have adopted California emission regulations.

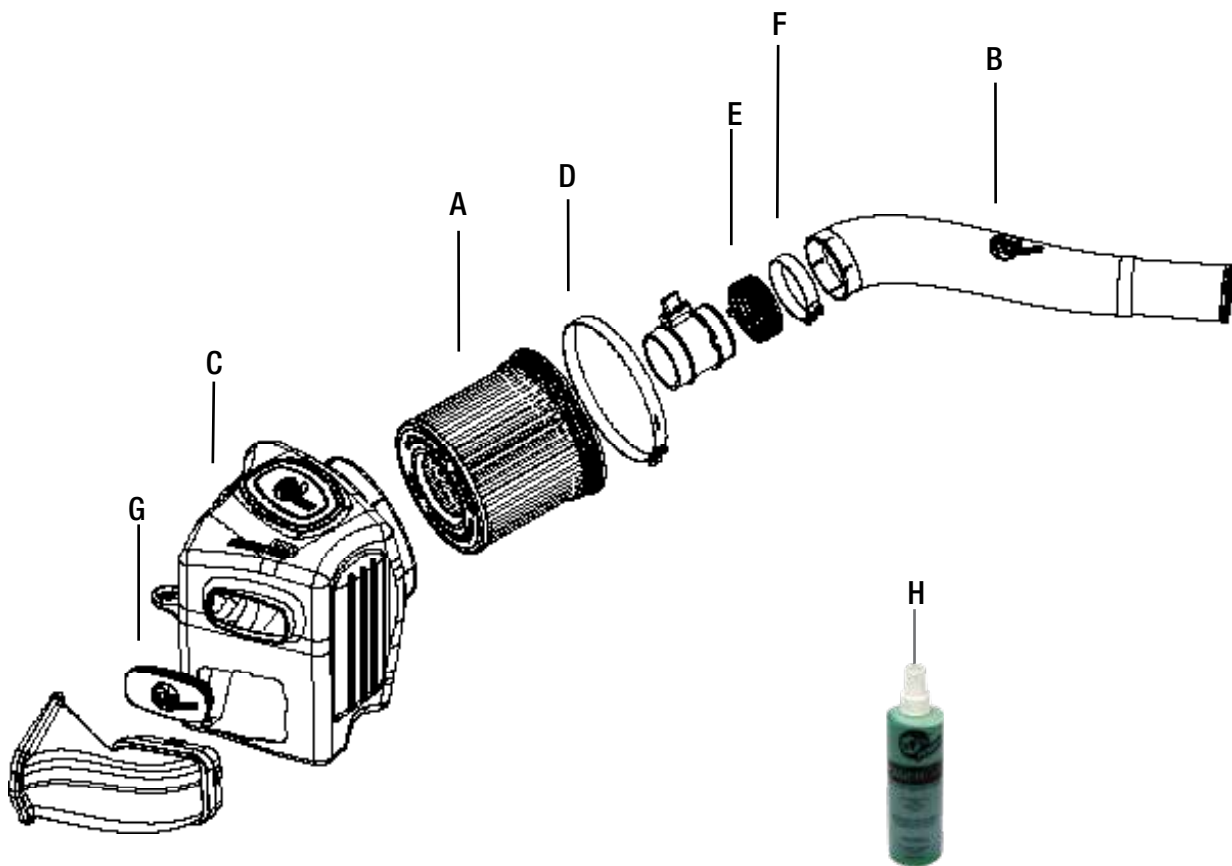



Refer to Figure A for Steps 1-2

- Step 1: Remove the engine cover by first lifting upward then pulling the cover towards you.
- Step 2: Disconnect the MAF (mass air flow) sensor wiring harness (1) by first pulling on the red clip, then squeeze the sensor and pull.

**Figure B****Refer to Figure B for Step 3**

Step 3: Loosen the clamp at the MAF cartridge ② and compress back.



Refer to Figure C for Step 4

Step 4: Remove the entire OE intake assembly by firmly lifting up to clear the plastic mounting pegs and then twisting the assembly towards you.



Figure D

Refer to Figure D for Steps 5-6

Step 5: Using your 8mm shallow socket, loosen the clamp ③ at the turbo adaptor boot.

Step 6: Remove the stock intake tube by pulling up and out towards you, off its mounting peg.

**Figure E****Refer to Figure E for Steps 7-8**

Step 7: Apply a small amount of lubricant (WD-40 recommended) to the AL end of the aFe tube and insert (4) into the OE turbo adaptor boot. Do not tighten the clamp yet.

Step 8: Slip one of the smaller t-bolt clamps (5) over the tube as shown. Do not tighten at this time.

**Figure F****Refer to Figure F for Steps 9-10**

Step 9: Using a T20 Torx driver, remove both screws ⑥ securing the MAF cartridge to the OE intake housing.

Step 10: Remove the O-ring on the MAF cartridge.

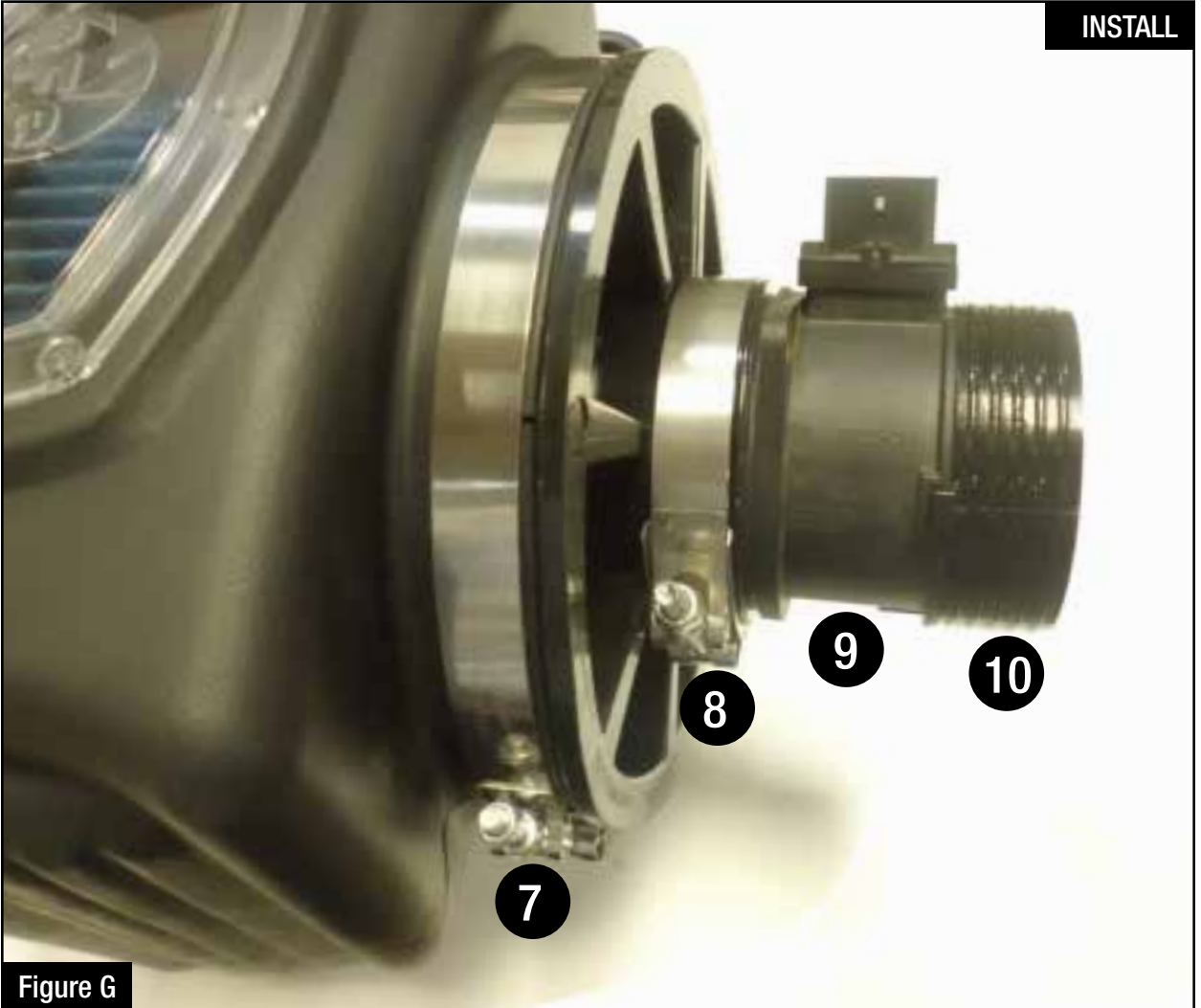
**Figure G****Refer to Figure G for Steps 11-16**

Step 11: Slip the large t-bolt clamp (7) over the aFe housing as shown.

Step 12: Clean the inside of the rotomold housing flange and both mating surfaces of the filter flange (acetone recommended).

Step 13: Insert filter & t-bolt clamp (8) into the housing as shown. Tighten large t-bolt clamp at this time.

Step 14: Insert the MAF cartridge into the filter flange (9) as shown. Tighten the small t-bolt clamp at this time.

*NOTE: Be careful not to overtighten the t-bolt clamp on the MAF cartridge.

Step 15: Slide the provided polyurethane adaptor coupling (10) over the MAF cartridge, lining up the locator tabs.

Step 16: Clean the mating surface of the polyurethane adaptor coupling using acetone.

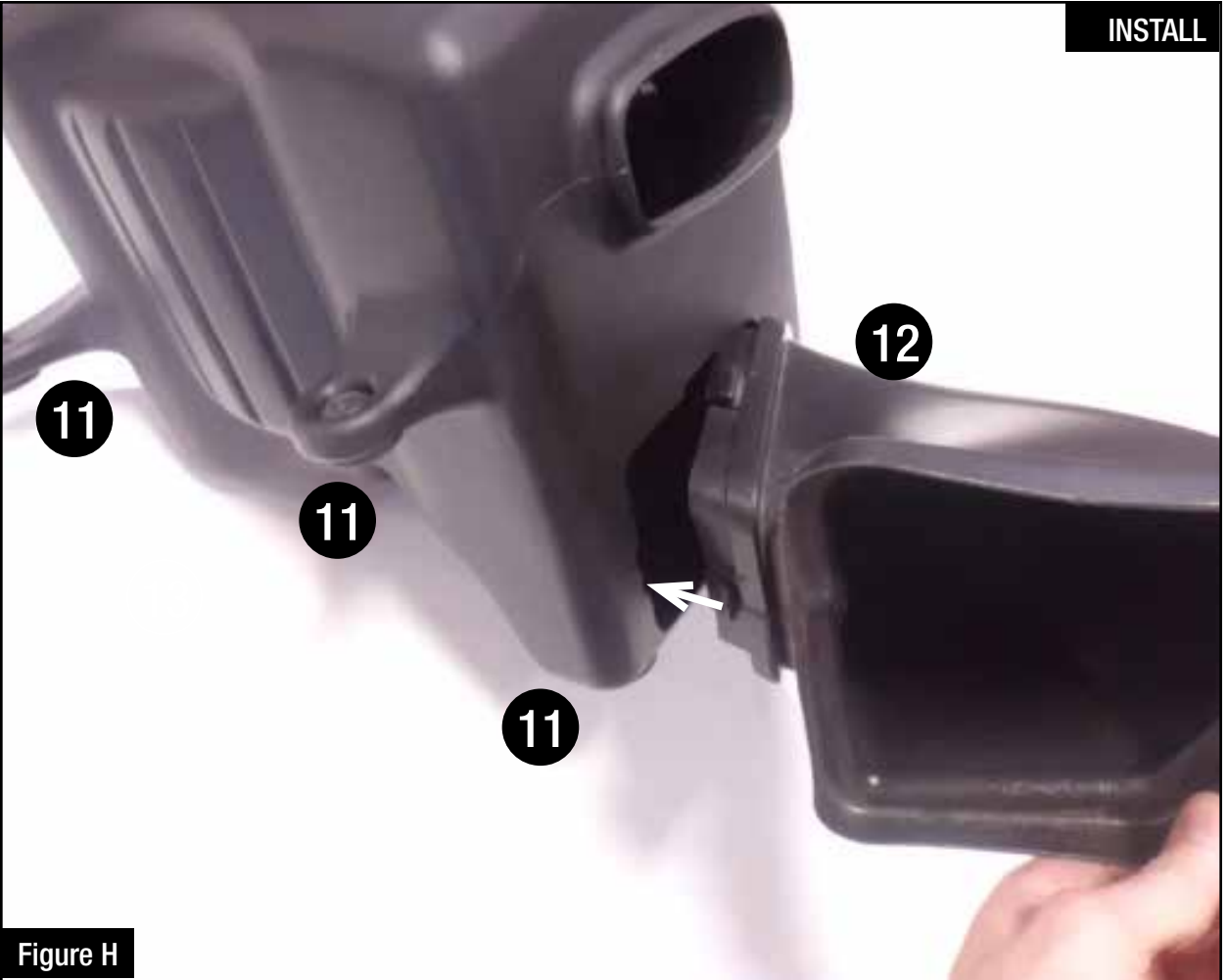
**Figure H****Refer to Figure H for Steps 17-18**

Step 17: Transfer 3 rubber grommets (11) from the OE air box to the aFe housing in the locations shown.

Step 18: Transfer the OE air scoop to the aFe housing (12), starting with one end in first then rotate the other end in until you feel it “lock” into place.

Figure I

Refer to Figure I for Steps 19-22

- Step 19: Spray a little hair spray onto the mating surface of the urethane adaptor coupling.
- Step 20: Apply some WD-40 to the inside of the rubber grommets; this helps them slide over the plastic mounting locations easier.
- Step 21: Lower the intake assembly into the engine bay as shown; roughly lining up the three mounting locations.
- Step 22: Be certain the lower grommet is properly aligned with its plastic mounting peg first. Once all 3 grommets are aligned with the mounting pegs, firmly press down on the housing.



Figure H

Refer to Figure H for Steps 23-27

Step 23: Align the tube with the MAF cartridge and then slip the tube over the polyurethane adaptor up to the 2 locator tabs.

Step 24: Tighten the t-bolt clamp (13) over the MAF cartridge.

*NOTE: Be careful not to overtighten the t-bolt clamp on the MAF cartridge.

*NOTE: Give the hair spray enough time to dry properly before driving vehicle.

Step 25: Reconnect the MAF sensor (14) to the MAF cartridge as shown and push the red clip to secure.

Step 26: Tighten the clamp (15) at the turbo adaptor boot.

Step 26: Make sure all clamps and connections are secure at this time.

Step 27: Reinstall the engine cover (16) at this time.

Your installation is now complete!

*Verify all connections are secure 100-200 miles after installation.



PRO DRY S Air Filter



P/N: 21-91100

Pro DRY S Restore Kit



P/N: 90-59999

SCORCHER HD Module



P/N: 77-42010

Oil Filter



P/N: 44-LF035

DPF Back Exhaust



P/N: 49-42044-B

Differential Cover



P/N: 46-70272

Intercooler Tubes



P/N: 46-20174-B

Intercooler

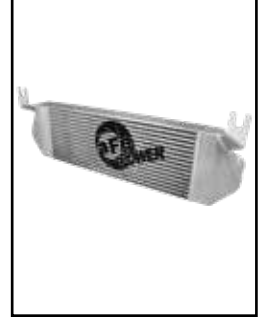

P/N: 46-20171



SAVE \$25 ON A REPLACEMENT **MOMENTUM** HD AIR FILTER. TO RECEIVE YOUR DISCOUNT PLEASE CALL **888.901.7693**

To purchase any of the items above, view airflow charts, dyno graphs, photos, and video; please go to aFepower.com.

Warranty

General Terms:

- aFe warrants their products to be free from manufacturer's defects due to workmanship and material.
- This warranty applies only to the original purchaser of the product and is nontransferable.
- Proof of purchase of the aFe product is required for all warranty claims.
- Warranty is valid provided aFe instructions for installation and/or cleaning were properly followed.
- Proper maintenance with regular inspections of product is required to insure warranty coverage.
- Damage due to improper installation, abuse, unauthorized repair or alteration is not warranted.
- Incidental or consequential damages or cost, including installation and removal of part, incurred due to failure of aFe product is not covered under this warranty.
- All warranty is limited to the repair and/or replacement of the aFe part. To request Return Goods Authorization ("RGA"), email RGA@afepower.com or call (951)493-7100. Upon receipt of the RGA, you must return the product to the address provided in the RGA, freight prepaid and accompanied with a dated proof of purchase and the RGA. Upon receipt of the defective product and upon verification of proof of purchase, aFe will either repair or replace the defective product within a reasonable time, not to exceed thirty days.

Product Category	P/N Prefix	Warranty duration
Direct OE Replacement Filters	10, 11, 30, 31, 71, 73	Life of the vehicle
Racing Filters	18	1 year
Universal	21, 24, 72	2 years
Air Intake Systems	50, 51, 54, 55, 75	2 years
Exhaust Systems	49	2 years
Intercoolers & Intercooler Tubes	46-2	2 years
Intake Manifolds	46-1	2 years
Differential Cover	46-7	Life of the vehicle
Exhaust Manifolds	46	2 years
Throttle Body Spacers	46-3	2 years
Fluid Filters	44	90 days
Pre-Filters	28	2 years
Heavy Duty OE Replacement	70	2 years
PowerSports OE Replacement	81, 87	2 years
PowerSports Intake Systems	85	2 years

No other warranty expressed or implied applies nor is any person or advanced FLOW engineering authorized to assume any other warranty. Some States do not allow the exclusion or limitation of incidental or consequential damages or do not allow limitations on how long an implied warranty lasts, so the above limitations or exclusions may not apply to you. This warranty gives you specific legal rights, and you may also have other rights which vary from State to State.

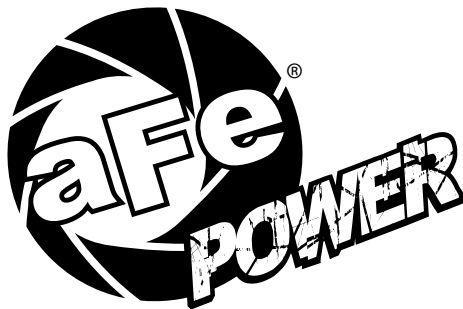

advanced FLOW engineering, inc.
252 Granite Street Corona, CA 92879
TEL: 951.493.7100 • TECH: 951.493.7185
E-Mail: Tech@aFepower.com