

BARRICADE

INSTALLATION INSTRUCTIONS HD OVERLAND DROP SIDE STEP BARS

2009-2018 1500 CREW CAB (INCLUDING 2019-2023 CLASSIC)

**2010-2023 2500/3500 CREW CAB (INCLUDING CHASSIS CAB DIESEL
MODELS)**

SKU: R114174 / HR27429

PARTS LIST:

| | | | |
|----|---|----|----------------------------------|
| 1 | Driver/Left Running Board | 6 | 8mm Bolt/Nut Plates |
| 1 | Passenger/Right Running Board | 18 | 8mm x 30mm Hex Bolts |
| 4 | Drop Steps | 24 | 8mm x 24mm OD x 2mm Flat Washers |
| 3 | Driver Front/Passenger Rear Mounting Brackets | 16 | 8mm x 22mm OD x 2mm Flat Washers |
| 3 | Passenger Front/Driver Rear Mounting Brackets | 12 | 8mm Lock Washers |
| 3 | Driver/Left Support Brackets | 6 | 8mm Hex Nuts |
| 3 | Passenger/Right Support Brackets | 22 | 8mm Nylon Lock Nuts |
| 12 | 10mm x 30mm Hex Bolts | 6 | 8mm Plastic Retainers |
| 24 | 10mm x 20mm OD x 2mm Flat Washers | 12 | 6mm x 25mm Hex Bolts |
| 12 | 10mm Nylon Lock Nuts | 24 | 6mm x 22mm OD x 2mm Flat Washers |
| 8 | 8mm Double Bolt Plates | 12 | 6mm Nylon Lock Nuts |

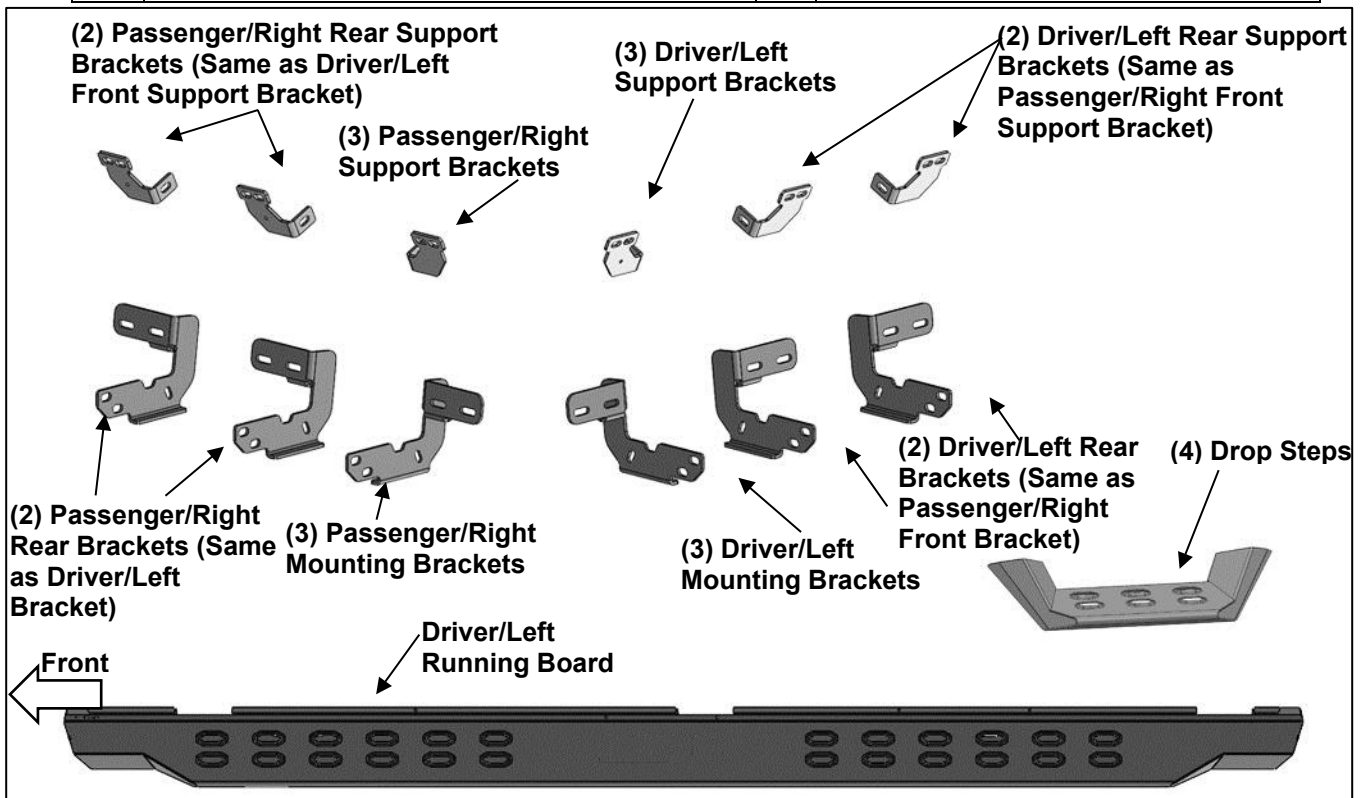

PROCEDURE: REMOVE CONTENTS FROM BOX. VERIFY ALL PARTS ARE PRESENT. READ INSTRUCTIONS CAREFULLY BEFORE STARTING INSTALLATION. DRILLING MAY BE REQUIRED.

- Starting at the driver side-front of the vehicle, remove the sealing tape covering the factory holes in the side of the inner panel, **(Figure 1)**.
- Determine the correct procedure to attach the driver side front Bracket for your model/year:

Models without factory threaded inserts in body panel:

- Select (1) 8mm Bolt/nut Plate, **(Figure 2)**. Partially thread an 8mm Hex Bolt onto the threaded end of the Nut Plate, **(Figure 3)**. Thread the Hex Bolt in until it is flush with the welded nut. Use the Hex Bolt as a handle and insert the Bolt and Nut Plate into the oval hole, **(Figure 4)**. Feed the threaded bolt on the Bolt Plate through one of the hex shaped factory holes.
- Thread (1) 8mm Plastic Retainer onto the threaded end and down tight against the body panel, **(Figure 5)**. **NOTE:** The Plastic Retainer is designed to keep the Bolt/Nut Plate from falling into the body panel and to aid in Bracket installation.
- Select (1) Driver/Left Bracket, **(Figure 6)**. Attach the Bracket to the threaded end of the Bolt Plate with (1) 8mm Flat Washer, (1) 8mm Lock washer and (1) 8mm Hex Nut, **(Figure 6)**.

IMPORTANT: Driver/Left Front Bracket is the same as the Passenger/Right Center and Rear Brackets. Do not tighten hardware at this time.

- d. Remove the 8mm Hex Bolt from the nut on the Bolt Plate from **Step 2a**. Rotate the Bolt on the Bolt Plate until the threaded nut lines up with the remaining hole in the Mounting Bracket and body panel, (**Figure 7**). Attach the Bracket to the threaded Nut Plate with (1) 8mm x 30mm Hex Bolt, (1) 8mm Lock Washer and (1) 8mm Flat Washer, (**Figure 7**). Do not tighten hardware.

Models with factory threaded inserts:

- a. Attach (1) Driver/Left Mounting Bracket to the threaded inserts with (2) 8mm x 30mm Hex Bolts, (2) 8mm Lock Washers and (2) 8mm Flat Washer, (**Figures 8 & 9**). Do not tighten hardware.
3. Attach (1) Support Bracket to the back of the pinch weld with (2) 6mm Hex Bolts, (4) 6mm Flat Washers and (2) 6mm Nylon Lock Nuts, (**Figure 10**). Do not fully tighten hardware. **IMPORTANT:** 2009-12 models not equipped with factory holes will require drilling through the pinch weld to fully attach Bracket. Do not drill through pinch weld at this time, (**see Step 8**).
4. Attach the Support Bracket to the Mounting Bracket with (1) 8mm Hex Bolt, (2) 8mm Flat Washers and (1) 8mm Nylon Lock Nut, (**Figure 11**). Do not tighten hardware at this time.
5. Move along the side of the body panel to the center mounting location, (**Figure 12**). Repeat **Steps 1—4** to install (1) Driver/Left Center Mounting Bracket to the center mounting location.
6. Move to the rear location, (**Figure 13**). Repeat **Steps 1—4** to attach (1) Passenger/Right Front Mounting Bracket to the Driver/Left rear mounting location.
7. Select the Driver/Left Tube. Insert (2) 8mm Double Bolt Plates into the front (2) sets of (2) holes, (**Figure 14**). Attach (1) Drop Step to the (2) Double Bolt Plates with (4) 8mm x 22mm Flat Washers and (4) 8mm Nylon Lock Nuts, (**Figure 15**). Do not tighten hardware.
8. With assistance, line up the mounting tabs in the Driver/Left Tube to the rear faces of the Mounting Brackets. Secure the Tube to the Mounting Brackets with (6) 10mm Hex Bolts, (12) 10mm Flat Washers and (6) 10mm Nylon Lock Nuts, (**Figure 16**). Do not tighten hardware.
9. Properly level and adjust the Side Step and fully tighten all hardware.

2009-12 models requiring drilling through pinch trim:

- a. Level the Side Step to the vehicle. Make sure all (3) Brackets are tight against the bottom of the body panel and tighten all mounting hardware.
- b. Mark the location of the slots onto the pinch weld.
- c. Drill (2) 1/4" holes through the pinch weld for each Bracket. **IMPORTANT:** Do not drill too close to the bottom edge of the pinch weld. Drill the holes in the center of the marked slots.
- d. Repeat **Step 3** to attach the Brackets to the drilled holes in the pinch weld. Check for level then fully tighten all hardware.

10. Repeat **Steps 1—8** to attach the Passenger/Right Overland Drop Steps.

11. Do periodic inspections to the installation to make sure that all hardware is secure and tight.

To protect your investment: Do not use any type of polish or wax that may contain abrasives that could damage the finish. Mild soap may be used to clean the Overland Steps.

Driver/Left Side Installation Pictured

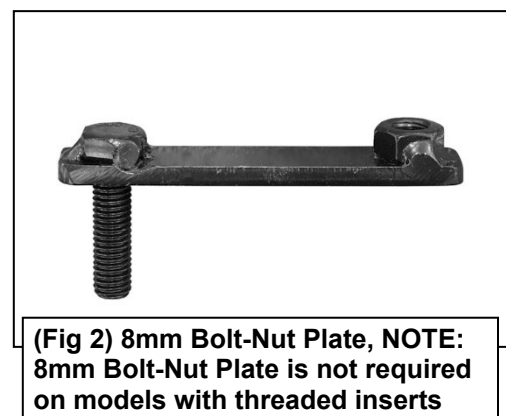
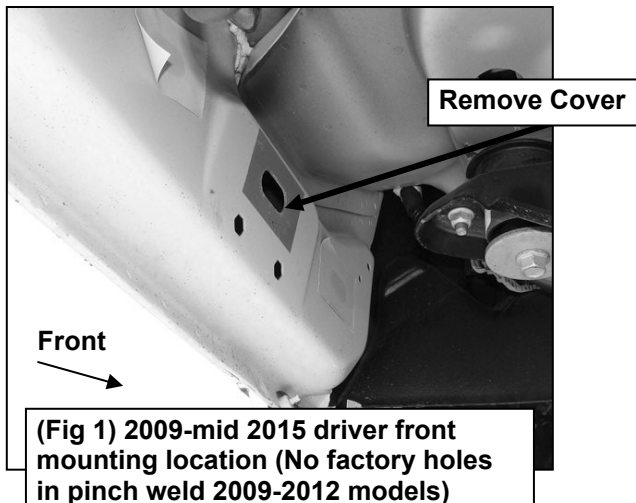

Driver/Left Side Installation Pictured

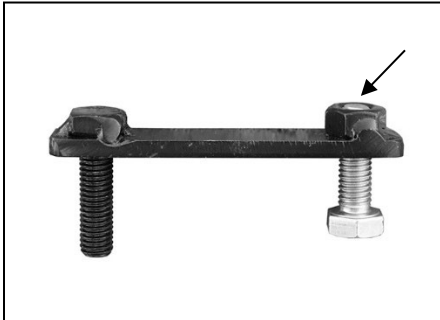

(Fig 3) Thread (1) 8mm Hex Bolt into the nut on the plate. Stop when bolt reaches end of nut as pictured

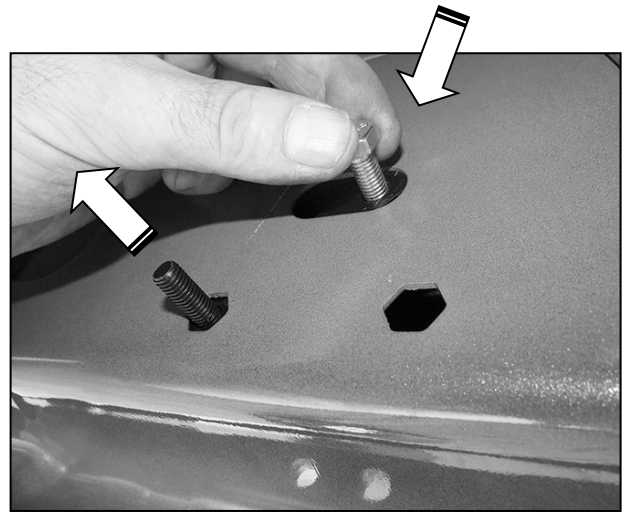

(Fig 4) Use the loose Hex Bolt as a handle. Insert the Bolt Plate into the oval hole and feed the threaded end out either factory hex shaped hole. IMPORTANT: Do not let go of the hex bolt until after Plastic Retainer has been threaded onto bolt (Fig 5)

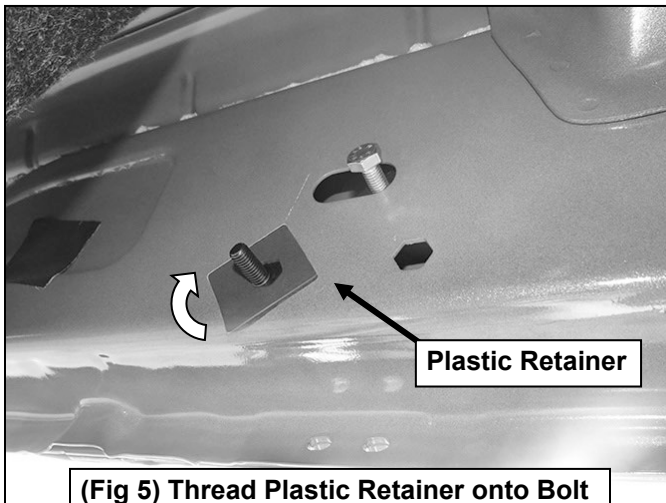

(Fig 5) Thread Plastic Retainer onto Bolt Plate to hold Bolt Plate in position.

8mm Flat Washer
8mm Lock Washer
8mm Hex Nut

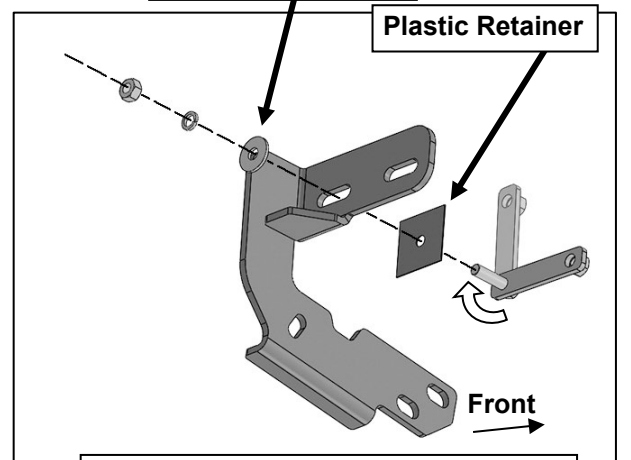

(Fig 6) Remove 8mm Hex Bolt. Rotate Bolt Plate to line up with remaining factory hex shaped hole

8mm Hex Bolt
8mm Lock Washer
8mm Flat Washer

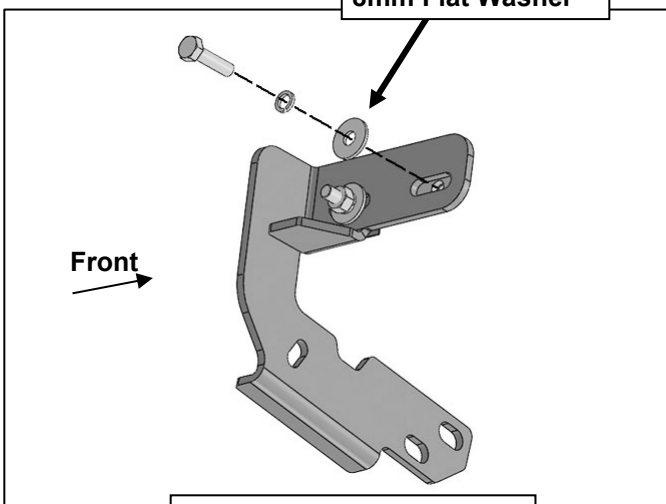

(Fig 7) Attach Bracket to threaded end of Bolt Plate

Driver/Left Side Installation Pictured

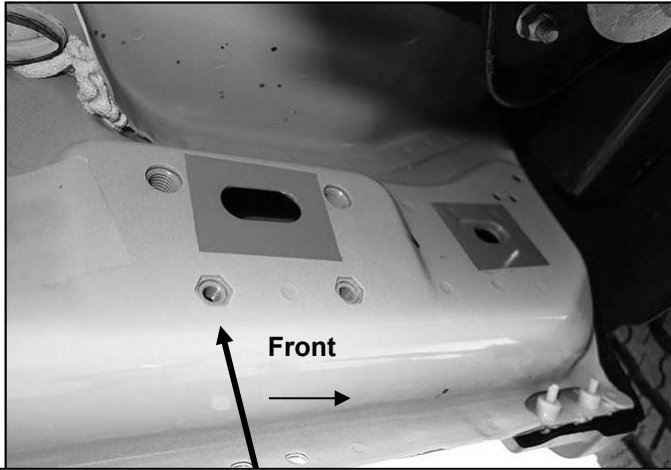

(Fig 8) Driver/left side front mid 2015-on (example of models with factory installed threaded inserts)

IMPORTANT: 2009-2012 models without holes in pinch weld will require drilling 1/4" holes through pinch weld to attach the bracket. Do complete installation of Running Boards first, level Running Board before drilling holes for bracket.

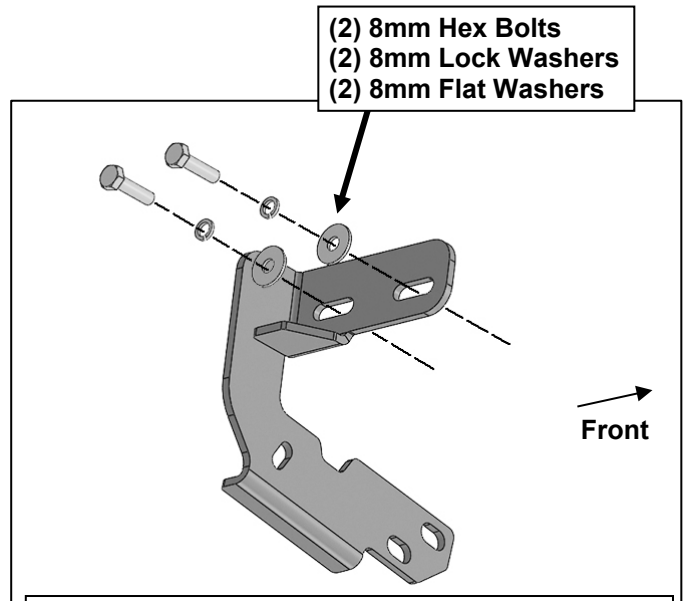

(Fig 9) Driver/left side front models with factory installed threaded inserts. Bolt Plate not required

- (2) 6mm Hex Bolts
- (4) 6mm Flat Washers
- Large Spacer
- (2) 6mm Nylon Lock Nuts

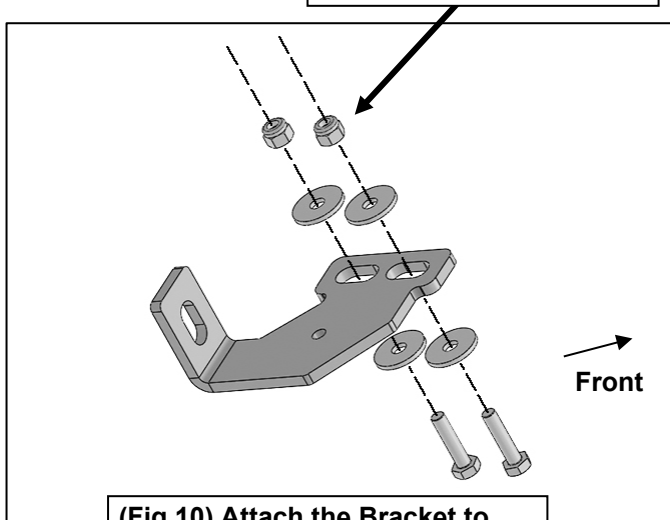

(Fig 10) Attach the Bracket to back of pinch weld (models with factory holes in pinch weld only)

Driver/Left Side Installation Pictured

8mm Hex Bolt
(2) 8mm Flat Washers
8mm Nylon Lock Nut

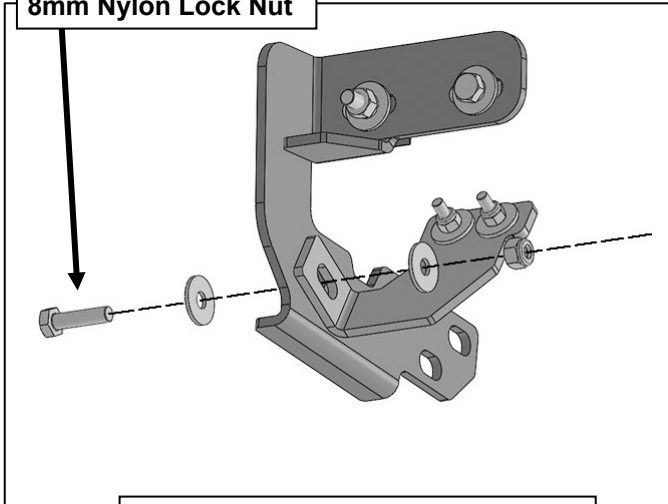

(Fig 11) Attach the Support Bracket to back of pinch weld (models with factory holes in pinch weld only)

IMPORTANT: 2009-2012 models without holes in pinch weld will require drilling 1/4" holes through pinch weld to attach the bracket. Do complete installation of Running Boards first, level Running Board before drilling holes for bracket.

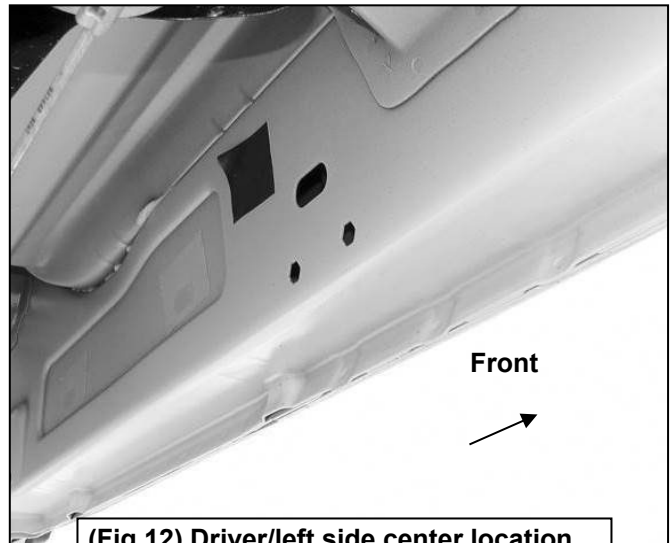

(Fig 12) Driver/left side center location

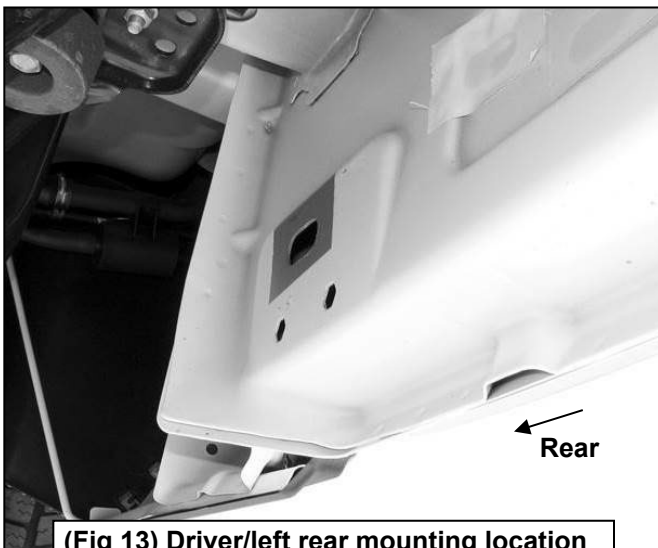

(Fig 13) Driver/left rear mounting location

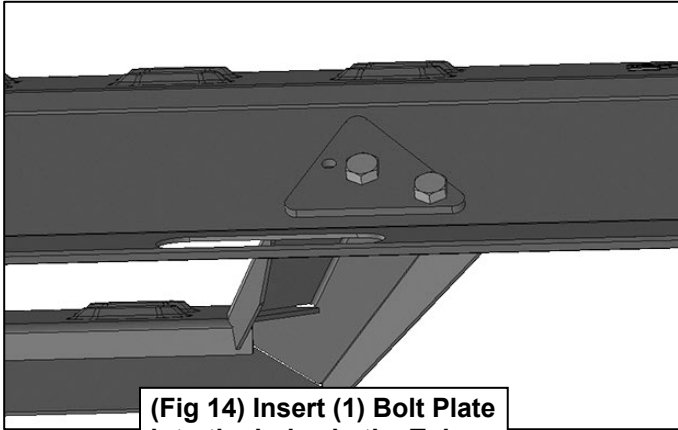

(Fig 14) Insert (1) Bolt Plate into the holes in the Tube

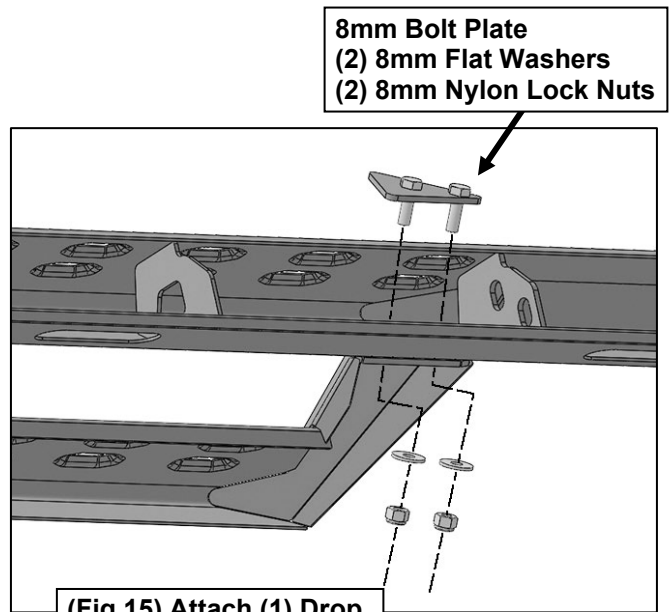

**8mm Bolt Plate
(2) 8mm Flat Washers
(2) 8mm Nylon Lock Nuts**

(Fig 15) Attach (1) Drop Step to (2) Bolt Plates

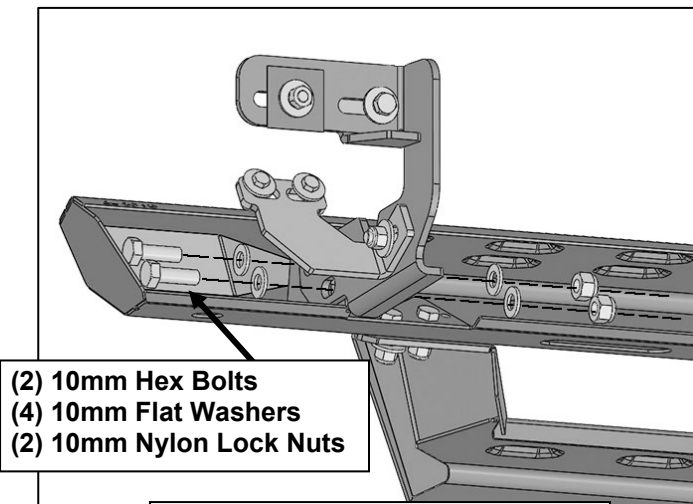

**(2) 10mm Hex Bolts
(4) 10mm Flat Washers
(2) 10mm Nylon Lock Nuts**

(Fig 16) Attach the Driver/Left Step to the (3) Mounting Brackets