

IARMOR EDGE™

PART#: IA-N258

BEFORE INSTALLATION

REMOVE CONTENTS FROM BOX. VERIFY ALL PARTS ARE PRESENT. READ INSTRUCTIONS CAREFULLY BEFORE STARTING INSTALLATION. ASSISTANCE IS RECOMMENDED. THANK YOU FOR CHOOSING OUR PRODUCT!

Torque Value

Fastener Size	Tightening Torque (ft-lbs)
6mm	6-7
8mm	16-18
10mm	31-32
12mm	56-58
14mm	92-94

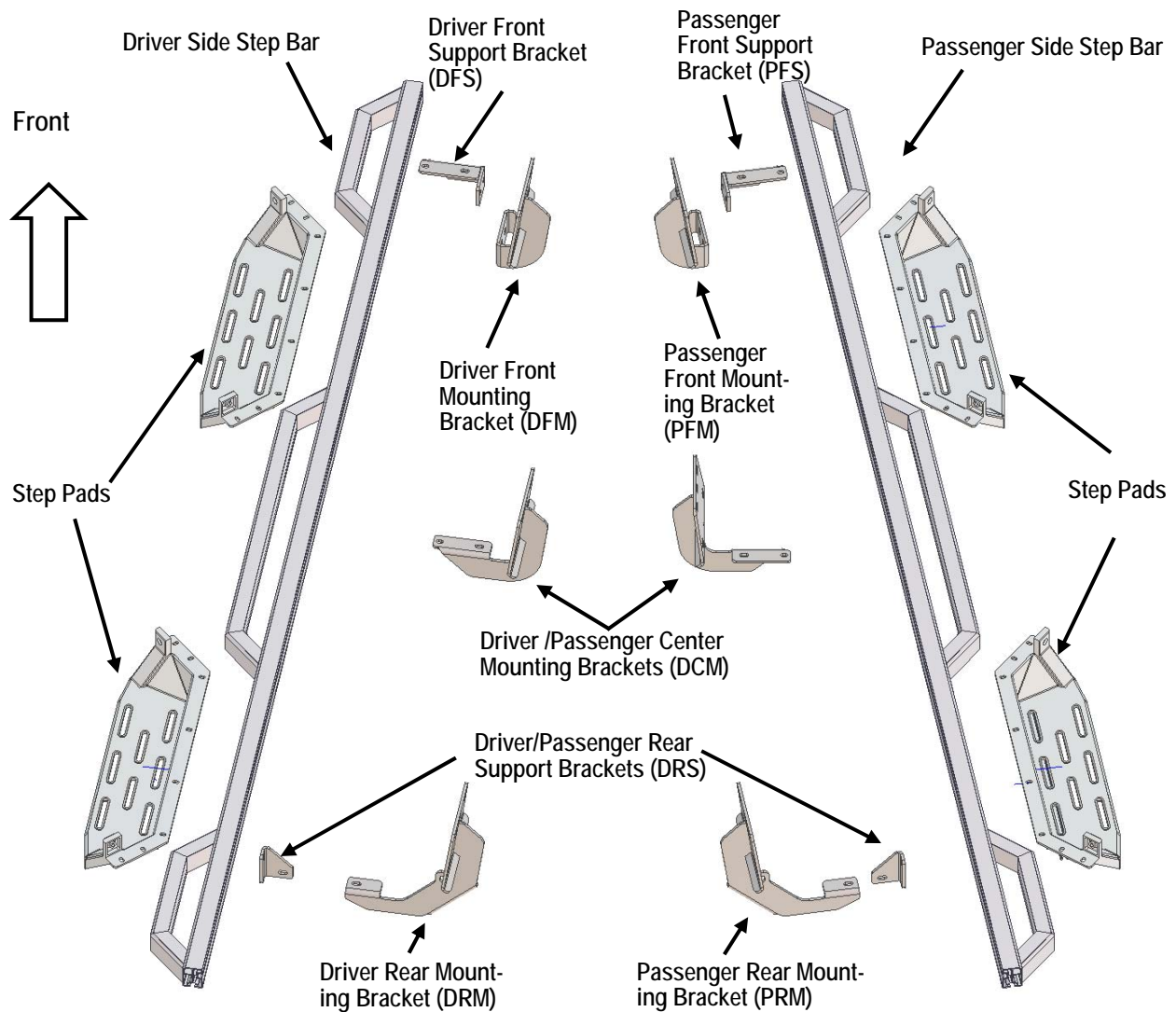

Customer Support: info@iarmorauto.com

iArmor®

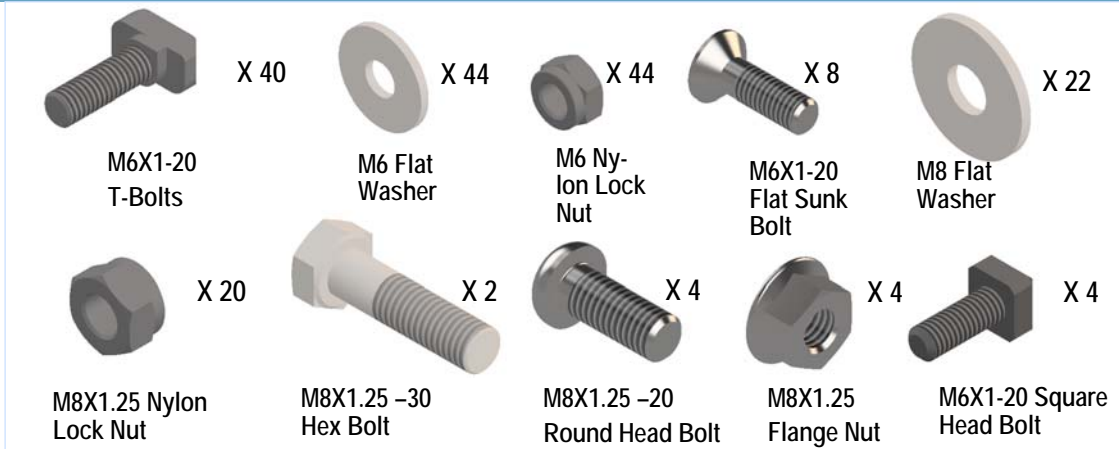

The instruction here is for your reference only. We strongly recommend the professional installer for best result. We are not responsible for any damage caused by the installation.

STEP 1

Install the Step Pads onto the step bars with (32) M6X1-20 T-Bolts, (32) M6 Flat Washers, (32) M6X1 Nylon Lock Nuts and (8) M6X1-20 Flat Sunk Head Bolts.

- (8) M6X1-20 T-Bolts
- (8) M6 Flat Washers
- (8) M6X1 Nylon Lock Nuts

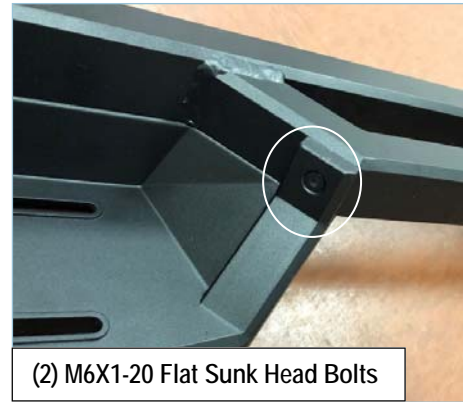
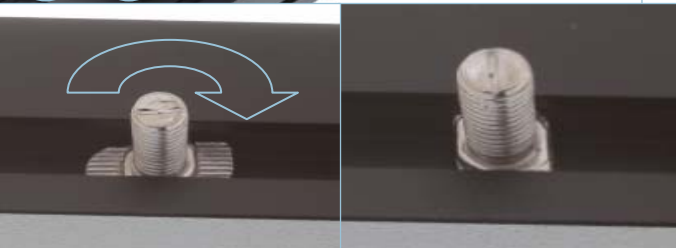

(2) M6X1-20 Flat Sunk Head Bolts

STEP 2

Start the installation under the passenger side of the vehicle. Locate the front (3) factory studs along the inner side of the body panel, (Fig 1). **NOTE:** Use a wire brush to remove paint buildup on the threaded studs before installing brackets.

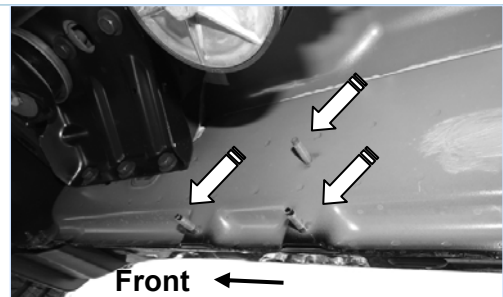

(Fig 1) Passenger Side Front Mounting Location

Customer Support: info@iarmorauto.com

iArmor®

STEP 3

Select (1) Passenger Front Mounting Bracket (PFM) and (1) Passenger Front Support Bracket (PFS), Assemble PFM and PFS together with (2) M8X1.25-20 Round Head Bolts (2) M8 Flat Washers and (2) M8X1.25 Flange Nuts. Attach the Assembled Mounting Bracket to the (3) factory studs with (3) M8 Flat Washers and (3) M8X1.25 Nylon Lock Nuts, (Fig 2 & 3). Leave brackets loose at this time.

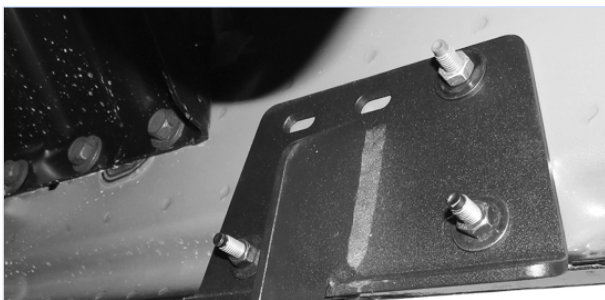
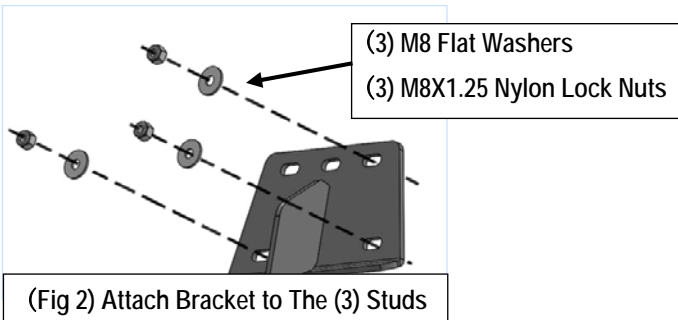

(Fig 3) Passenger Front with Mounting Bracket Installed

STEP 4

Locate the Passenger Center Mounting position (Fig 4), and install the Passenger Center Bracket (Fig 5).

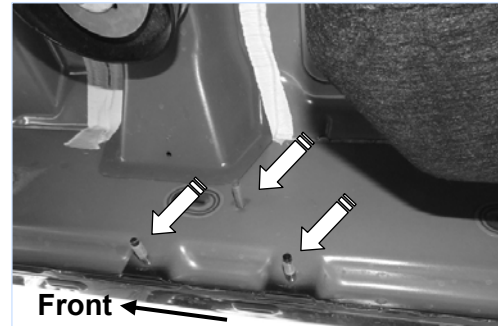

(Fig 4) Passenger Side Center Mounting Location

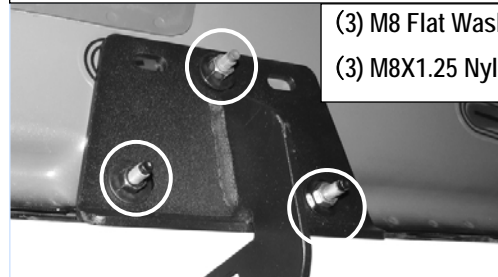

(Fig 5) Passenger Center Side with Mounting Bracket Installed

STEP 5

Repeat Steps 2 & 3 to install Passenger Rear Mounting Brackets (Fig 6&7). And attach the Passenger Rear Support Bracket (PRS) to the Passenger Rear Mounting Bracket (PRM) with (1) M8X1.25-30 Hex Bolt, (2) M8Flat Washer and (1) M8X1.25 Nylon Lock Nut.

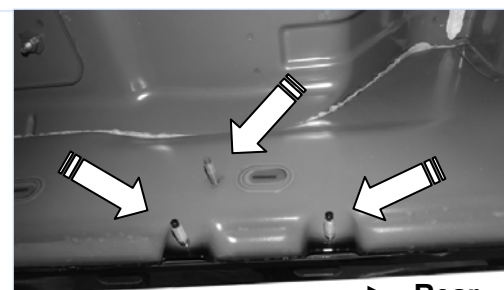

(Fig 6) Passenger Side Rear Mounting Location

iArmor[®]

- (3) M8 Flat Washers
- (3) M8X1.25 Nylon Lock Nuts



(Fig 7) Passenger Rear Side with Mounting Bracket Installed

STEP 6

Attach the Assembled Step Bar to the Brackets using (4) 6mmX1-20mm T-Bolts, (2) M6X1-20 Square Head Bolt, (6) M6 Flat Washers and (6) M6 Nylon Lock Nuts (**Fig 8**). Do not tighten hardware at this time.

STEP 7

Level and adjust the Step Bar as necessary and fully tighten all hardware.

STEP 8

Repeat **Steps 1—7** for Driver/left side Step Bar installation.

STEP 9

Do periodic inspections to the installation to make sure that all hardware is secure and tight.

Attention

In order to protect your bars/boards, please use only mild soap/non-abrasive products for cleaning.

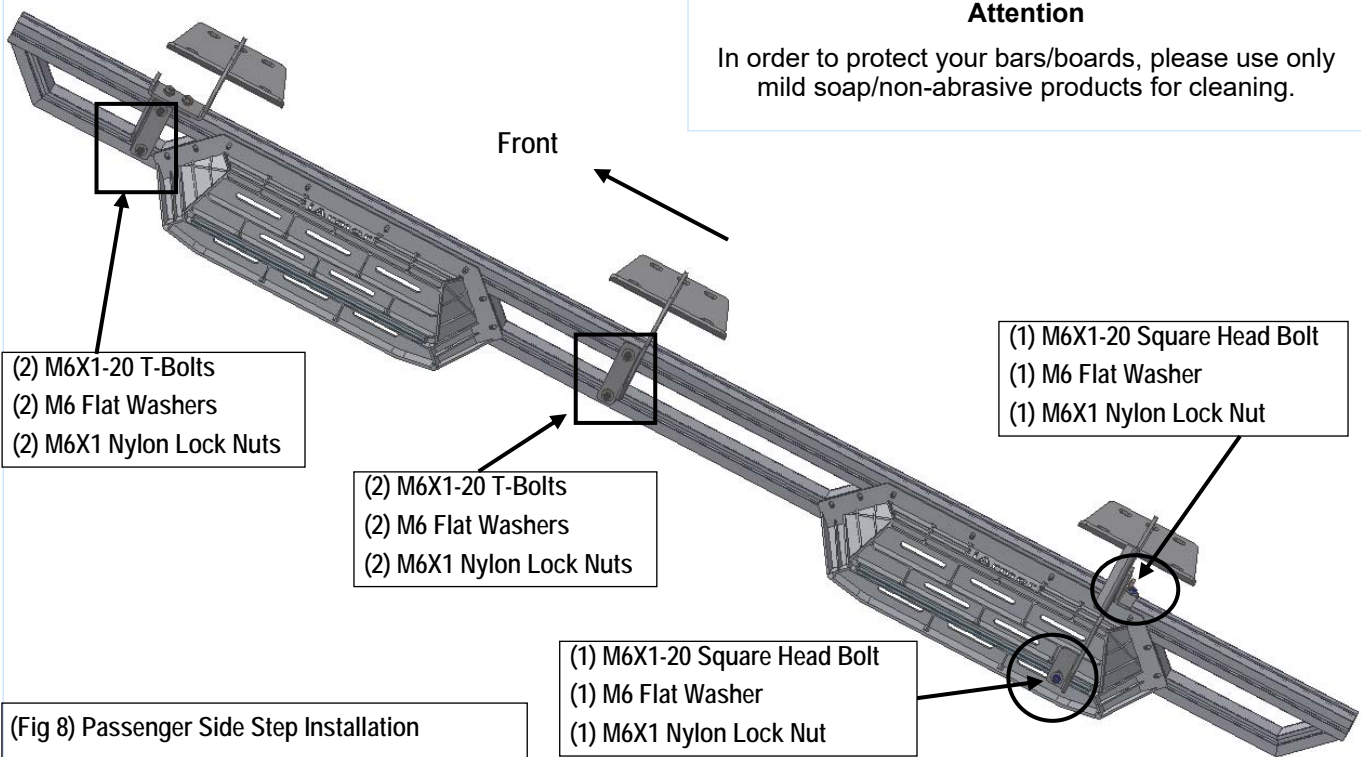

Customer Support: info@iarmorauto.com