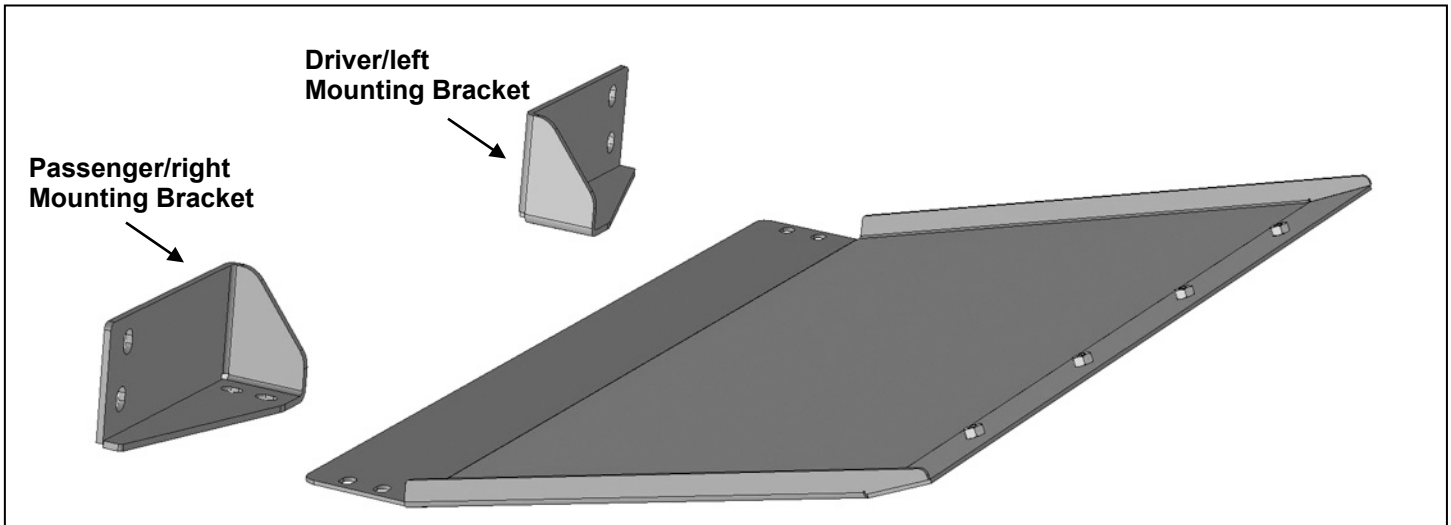

PARTS LIST:

1	Skid Plate	16	8mm x 24mm x 2mm Flat Washers
1	Driver/Left Skid Plate Bracket	4	8mm Lock Washer
1	Passenger/Right Skid Plate Bracket	8	8mm Nylon Lock Nuts
8	8-1.25mm x 25mm Button Head Bolt	1	5mm Allen Wrench

**PROCEDURE:**

REMOVE CONTENTS FROM BOX. VERIFY ALL PARTS ARE PRESENT. READ INSTRUCTIONS CAREFULLY BEFORE STARTING INSTALLATION. ASSISTANCE IS RECOMMENDED.

1. On models with "Active Retractable Air Dam," unplug and remove air dam. Air dam cannot be reinstalled with Skid Plate.
2. Select the driver/left Mounting Bracket, **(Figure 1)**. Attach the Mounting Bracket to the (2) threaded studs in the bottom of the lower frame with (2) 8mm Flat Washers and (2) 8mm Nylon Lock Nuts, **(Figures 1 & 2)**. Do not fully tighten at this time. **NOTE:** On models without active air dam, use a wire brush or thread tapping die to remove paint or undercoating from studs before installing Bracket. Repeat this **Step** to attach the passenger/right side Mounting Bracket.
3. Carefully unwrap the Skid Plate. With assistance, line up the front of the Skid Plate with the back of the LD2 Bumper. Attach the Skid Plate to the Bumper with the included (4) 8mm Button Head Bolts, (4) 8mm Lock Washers and (4) 8mm Flat Washers, **(Figures 3 & 4)**. Leave hardware loose at this time.
4. Attach the tail end of the Skid Plate to the bottom of the previously installed Mounting Brackets with the included (4) 8mm Button Head Bolts, (8) 8mm Flat Washers and (4) 8mm Nylon Lock Nuts, **(Figures 5 & 6)**.
5. Level and adjust the Skid Plate and fully tighten all hardware.
6. Do periodic inspections to the installation to make sure that all hardware is secure and tight.

To protect your investment: Wax this product after installing. Regular waxing is recommended to add a protective layer over the finish. Do not use any type of polish or wax that may contain abrasives that could damage the finish. Mild soap may be used to clean the Skid Plate.

- (2) 8mm Flat Washers
- (2) 8mm Nylon Lock Nuts

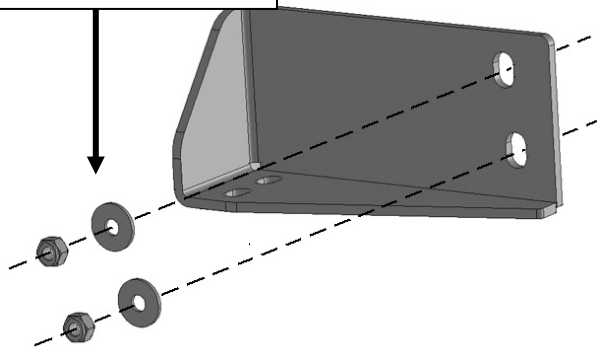

(Fig 1) Attach driver/left Bracket to studs in frame

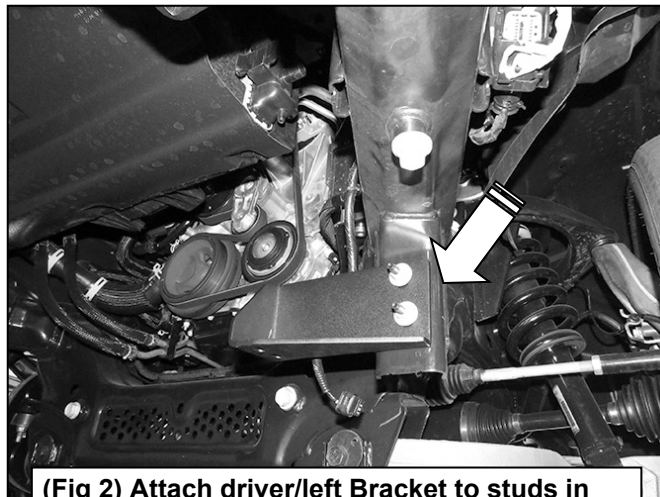

(Fig 2) Attach driver/left Bracket to studs in frame. NOTE: active air dam must be removed

Front

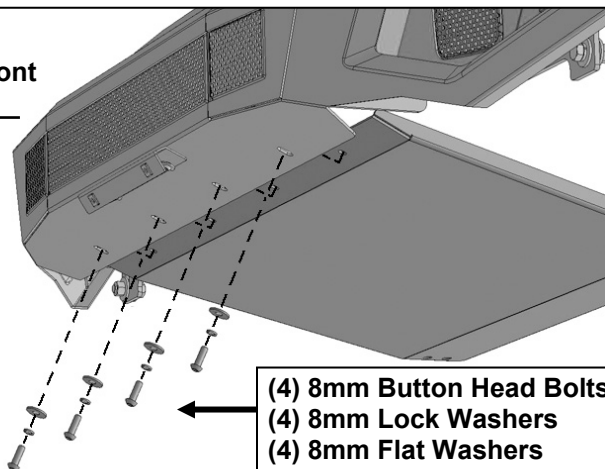

(Fig 3) Attach Skid Plate to back of Bumper

Front

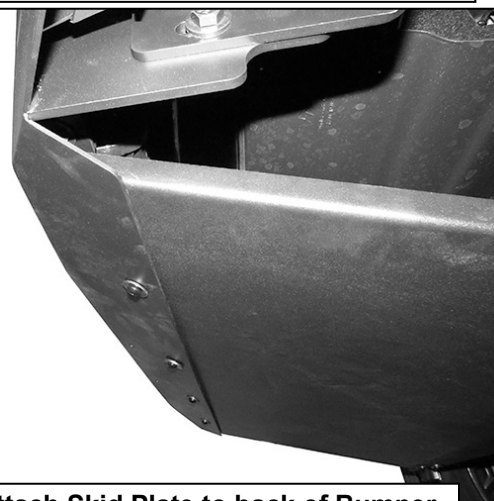

(Fig 4) Attach Skid Plate to back of Bumper

- (2) 8mm Button Head Bolts
- (4) 8mm Flat Washers
- (2) 8mm Nylon Lock Nuts

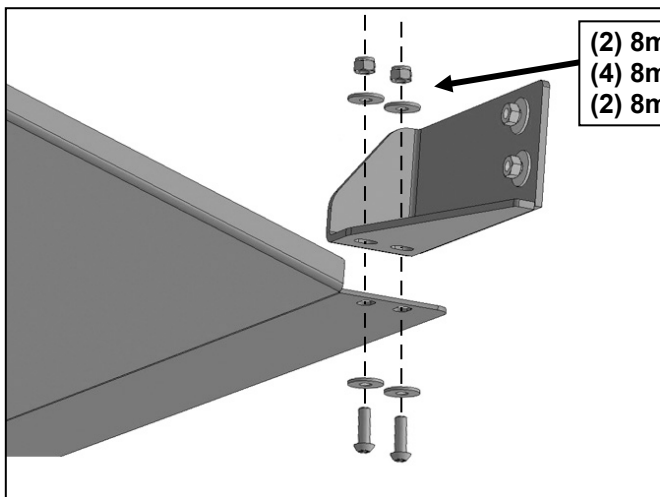

(Fig 5) Attach Skid Plate to Mounting Brackets

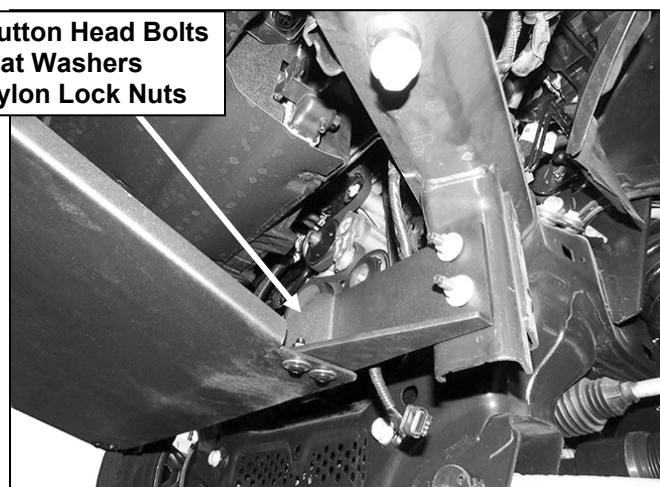

(Fig 6) Attach Skid Plate to Mounting Brackets