



RAM

INSTALLATION INSTRUCTIONS

Extreme HD Front Bumper with LED Fog Lights and RAM Logo

09-18 RAM 1500, 19-23 1500 "CLASSIC"

R131493

PARTS LIST:

1	LD1 Rear Bumper Assembly	4	12-1.75mm x 40mm Hex Bolts
1	Step Hole Plug	4	12mm x 37mm x 3mm Flat Washers
1	Push in License Plate Light	4	12mm Lock Washers
2	Plastic Plugs for license plate mount	2	4mm x 10mm Button Head Bolts
6	Sensor Retaining Caps	4	4mm x 12mm x 1mm Flat Washers
6	20mm x 10mm Foam Spacers	2	4mm Lock Washers
6	15.5mm x 25mm x 2mm Foam Washers	2	4mm Hex Nuts
6	Sensor Hole Plugs	12	4mm Self Tapping Screws
2	2009-18 1500 Wiring Harnesses	10	Nylon Cable Ties 200mm
4	2019-20 25-3500 Wiring Harnesses	1	2.5mm Wrench
1	Sensor Cover Kit	1	4mm Wrench
2	12mm Double Nut Plates		

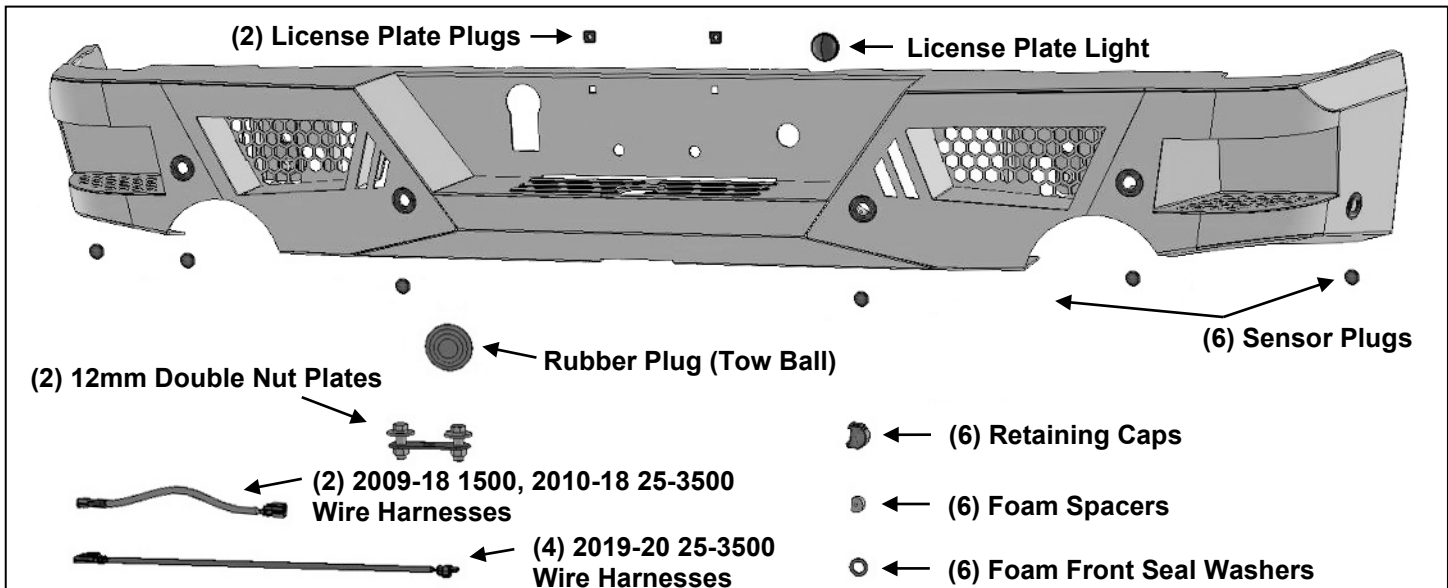

PROCEDURE:

REMOVE CONTENTS FROM BOX. VERIFY ALL PARTS ARE PRESENT. READ INSTRUCTIONS CAREFULLY BEFORE STARTING INSTALLATION. BUMPER IS HEAVY, ASSISTANCE IS HIGHLY RECOMMENDED TO AVOID POSSIBLE INJURY OR DAMAGE TO THE VEHICLE. ON MODELS WITH DUAL EXHAUST, ALLOW EXHAUST TO COMPLETELY COOL BEFORE STARTING INSTALLATION.

1. Start installation by unplugging the wiring harnesses leading to the rear bumper, (**Figures 1 & 2**). Move the wiring harnesses away from the bumper.
2. Remove the license plate. Remove the (2) hex bolts behind the license plate, (**Figure 3**).
3. Place blocks or jack stands under the bumper to support it during bumper bolt removal. Once the bumper has been safely supported, remove the (4) factory bumper bolts, (2 per side), and slide the bumper off of the end of the frame, (**Figures 4 & 5**). **WARNING!** Assistance is required to hold the bumper in place during hardware removal and to prevent the bumper from falling. Move the bumper to a clean stable work surface.
4. Remove the wiring harness and outer towing harness plug from the factory bumper, (**Figure 6**). Use the included Wire Ties to attach the factory wiring harness to the LD1 Bumper and away from exhaust.
5. Determine if the bumper is equipped with sensors.

Models without bumper sensors:

- a. From the front of the bumper, push the included Plastic Plugs into sensor mounting holes, (**Figure 7**).

Models with bumper mounted sensors:

- a. Remove parking sensors from plastic mounts in the factory bumper, (**Figure 8**). **NOTE:** Label sensors with location for proper reinstallation.
- b. Next, remove the silicone seal from the end of the sensor. Slide the included larger Sensor Seal over front of sensor, (**Figures 9 & 10**).

- c. Insert sensor with Seal into sensor mount, **(Figure 10)**. Place (1) Foam Spacer onto the end of the sensor.
- d. Push Sensor Retaining Cap onto sensor mount and snap into mounting holes, **(Figure 10)**.
- e. Repeat previous Steps to install remaining sensors.
- f. Attach factory wiring harness to sensors. **NOTE:** Use the included Wiring Harness Extensions as necessary to extend the reach of the harness to the sensors. **IMPORTANT:** kit includes **(2) 2009-18 1500 harnesses and (4) 2019-20 25-3500 harnesses**, match plugs on Harnesses to sensors and use correct harness as needed.

Models with TPMS (tire pressure monitoring system).

- a. Remove the sensor from the back of the bumper, **(Figure 11)**. **NOTE:** It may be necessary to partially disassemble the factory bumper to remove the sensor.
 - b. Attach the sensor to tabs on back of bumper with included (2) 4mm Button Head Screws, (4) 4mm Flat Washers, (2) 4mm Lock Washers and (2) 4mm Hex Nuts, **(Figure 12)**. Do Not Overtighten 4mm hardware or damage to sensor could result.
 - c. Once installed, plug wiring harness into TPMS sensor.
6. If installing lights, (lights not included), check for clearance around light. Remove back screens from light housings for additional clearance around lights as required, **(Figure 13)**. **IMPORTANT:** On models with Dual Exhaust, screens must be removed before installing the Bumper if lights are to be installed.
 7. With assistance, position the Bumper up to the brackets on the ends of the frame. Temporarily support the weight of the Bumper Assembly. **WARNING:** To avoid possible injury or damage to the vehicle, do not proceed until the Bumper is fully and safely supported.
 8. Line up the (2) mounting holes in the back of the driver/left side of the bumper with the brackets on the end of the frame. Slide (1) 12mm Double Nut Plate behind the mounting plate on the Bumper, **(Figure 14)**. Attach the Bumper to the frame and Nut Plate with (2) 12mm Hex Bolts, (2) 12mm Lock Washers and (2) 12mm Flat Washers, **(Figures 14 & 15)**. Repeat this **Step** to attach the passenger/right side of the Bumper. Leave hardware loose at this time.
 9. Slowly open the tail gate and check for clearance. Level and adjust Bumper and tighten all hardware.
 10. Snap the trailer plug into the opening in the Bumper, **(Figure 16)**. If necessary, use a flat blade screwdriver to carefully pry the lock tab on the clip out to help lock plug in place.
 11. Insert the included (2) push-in plugs to attach the license plate to the Bumper, **(Figure 17)**. Insert the included License Plate Light into the mounting hole in the bumper.
 12. Connect the license plate light harness to the License Plate Light. Reattach the wiring harness to the back of the trailer plug and back up sensors (if equipped). Use the included Wire Ties to secure the wiring harness to the bumper and frame. Seal off any open wire connections.
 13. Do periodic inspections to the installation to make sure that all hardware is secure and tight.

To protect your investment, Do not use any type of polish or wax that may contain abrasives that could damage the finish. Mild soap may be used to clean the LD1 Bumper assembly.

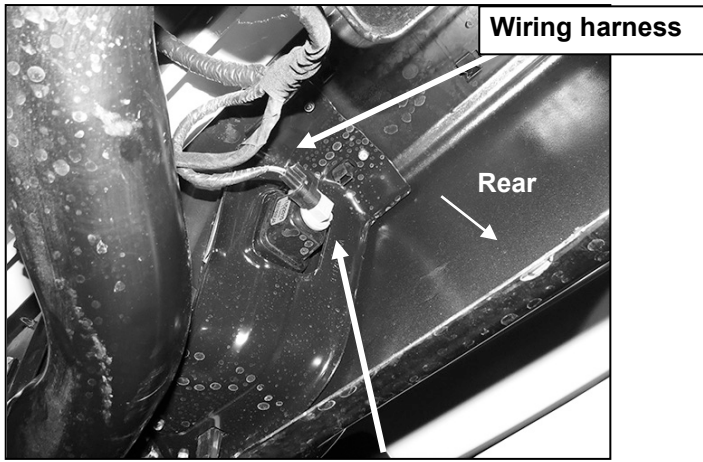

(Fig 1) Unplug license plate lights

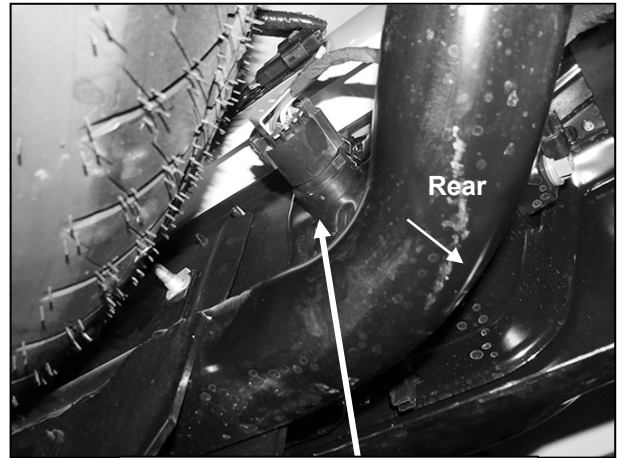

(Fig 2) Unplug trailer connector

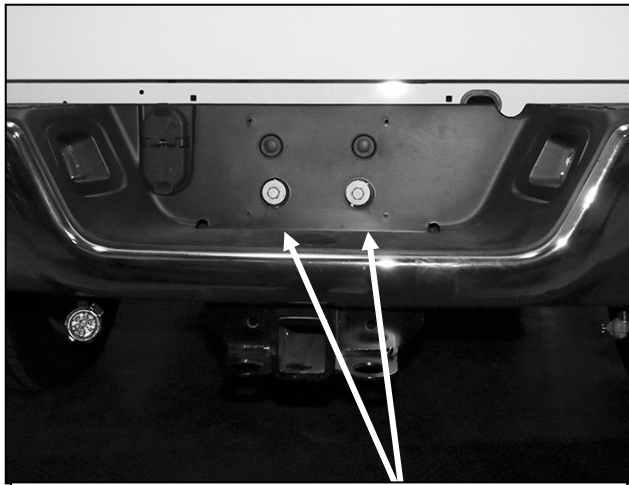

(Fig 3) Remove license plate and (2) hex bolts

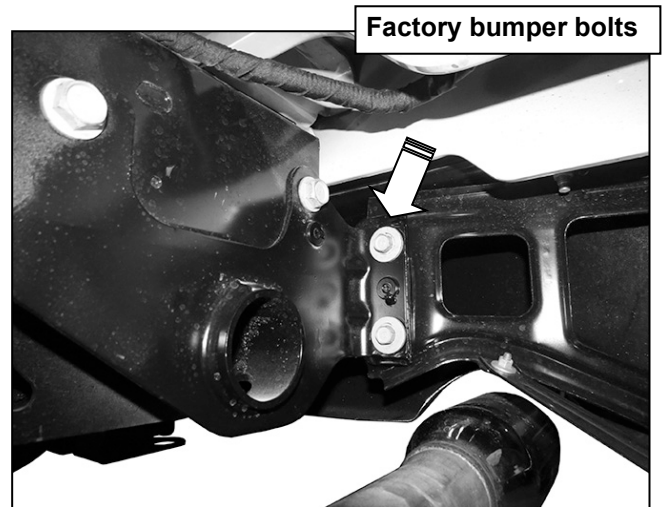

(Fig 4) Example of factory bumper bracket with (2) hex bolts pictured from behind bumper

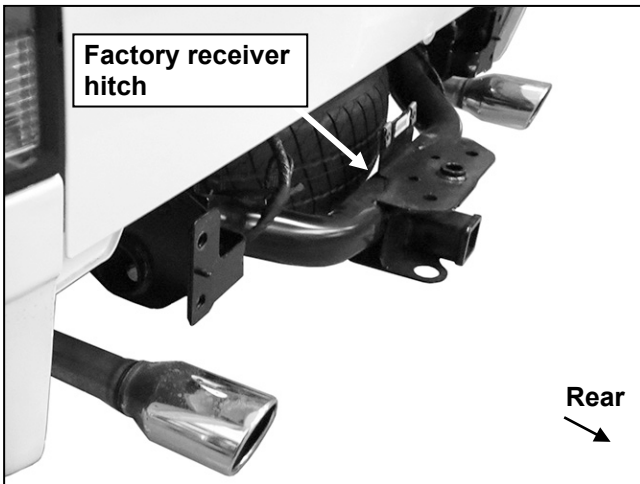

(Fig 5) Bumper completely removed (1500 model pictured)

WARNING! Do not remove bumper bolts unless it is properly supported on blocks or stands or the bumper may fall.
Models with dual exhaust, allow exhaust to completely cool before starting installation

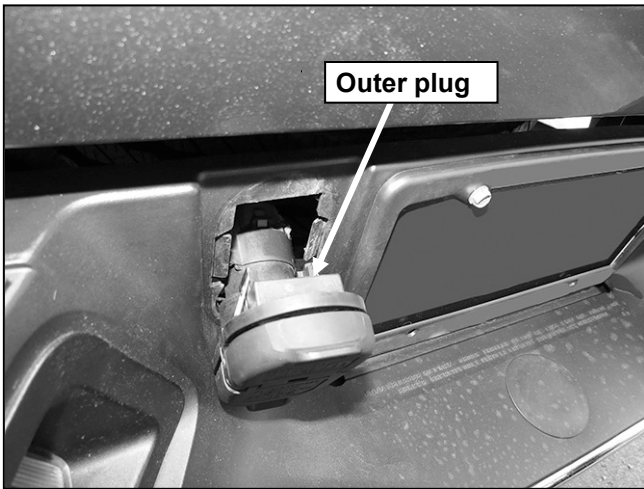

(Fig 6) Remove outer trailer plug from bumper

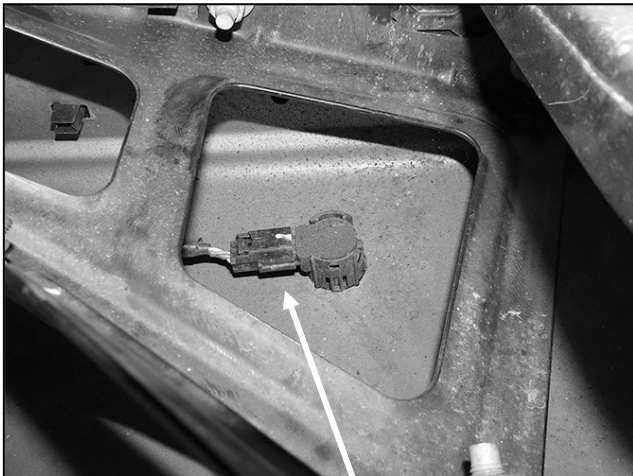

(Fig 8) Unplug the sensor first then remove the sensor from the mount. Disassemble bumper to remove all sensors and harness as equipped

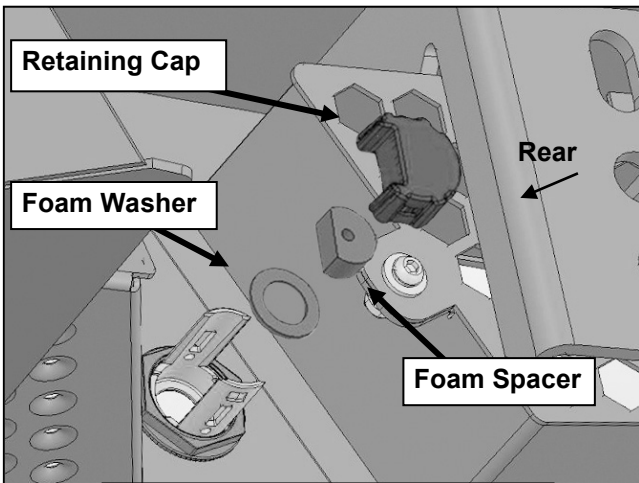

(Fig 10) Push sensor into sensor mount on the back of the Bumper

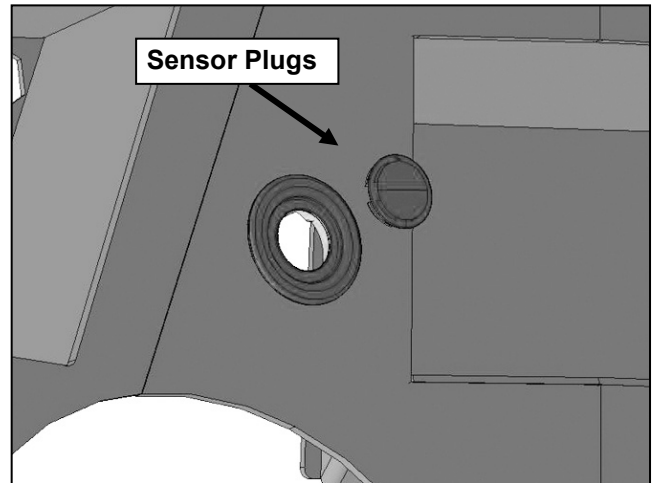

(Fig 7) Push sensor plug into sensor mount



(Fig 9) Remove the sensor from the mount (right) . Remove seal from end of sensor. Push Foam Seal onto end of sensor (Fig 10)

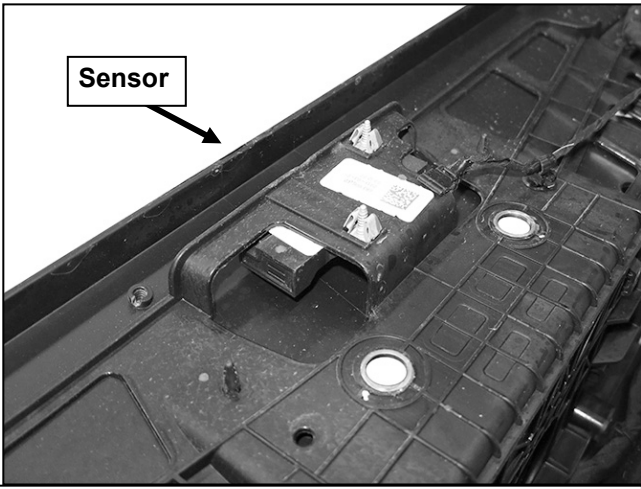

(Fig 11) Remove tire pressure monitoring sensor (TPMS) from back of bumper, if equipped

- (2) 4mm Screws
- (4) 4mm Flat Washers
- (2) 4mm Lock Washers
- (2) 4mm Hex Nuts

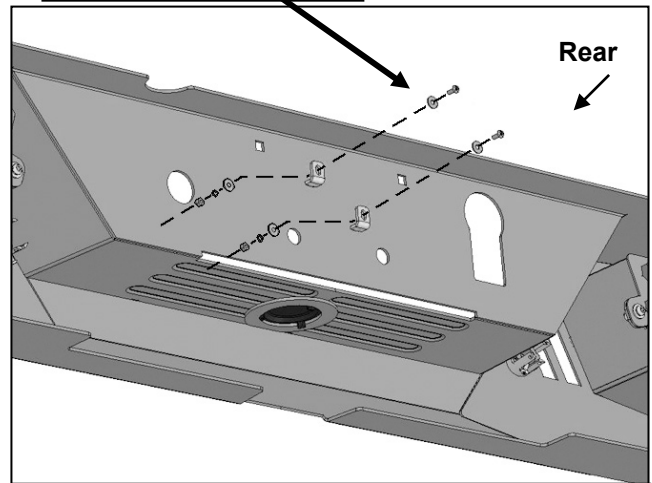

(Fig 12) Attach tire pressure monitoring sensor, if equipped, to tabs on back of bumper

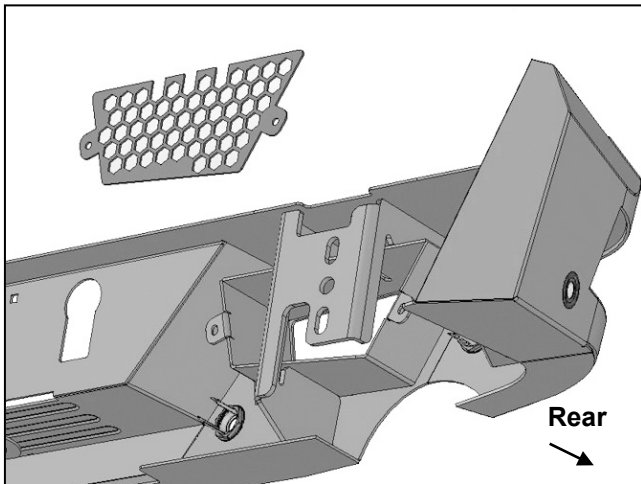

(Fig 13) Remove screens if necessary for additional clearance around or access to lights

IMPORTANT: On models with dual exhaust, if bumper installation will include accessory lights, check for clearance around lights before installing bumper. Screens cannot be removed once bumper is installed.

- (2) 12mm Hex Bolts
- (2) 12mm Lock Washers
- (2) 12mm Flat Washers

12mm Double Nut Plate

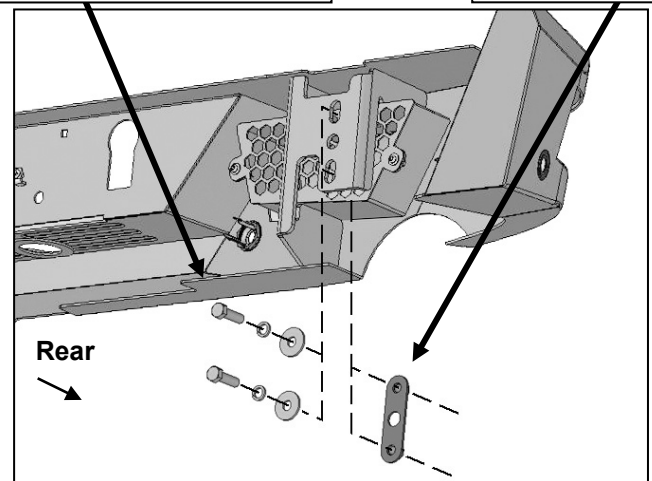

(Fig 14) Attach Bumper to end of frame. Driver/left side illustrated

WARNING! Do not crawl under bumper unless it is properly supported on blocks or stands or the bumper may fall.

- (2) 12mm Hex Bolts
- (2) 12mm Lock Washers
- (2) 12mm Flat Washers

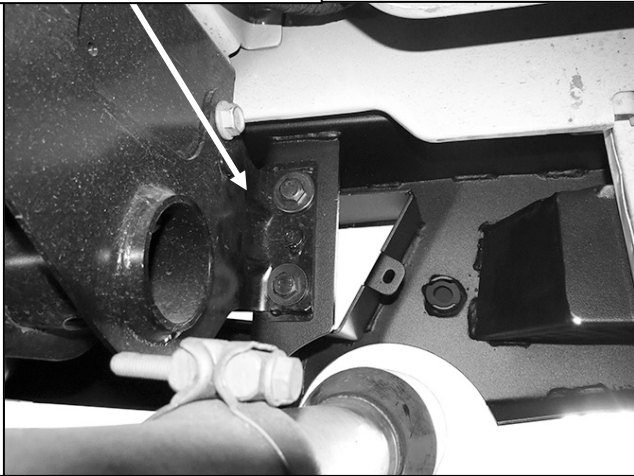

(Fig 15) Driver/left side pictured from behind bumper

WARNING! Do not crawl under bumper unless it is properly supported on blocks or stands or the bumper may fall.

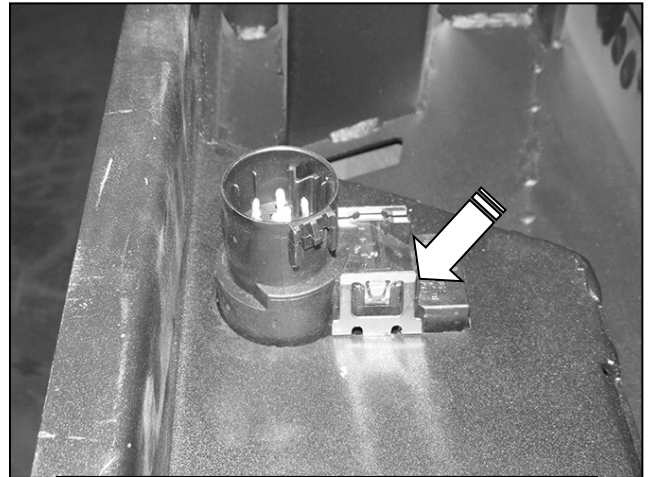

(Fig 16) Push plug into place. Carefully bend locking tab outward if necessary

