



**RAM**

**INSTALLATION INSTRUCTIONS**

**Extreme HD Front Bumper with LED Fog Lights and RAM Logo**

**13-18 RAM 1500, Excluding Rebel**

**R131495**

**PARTS LIST:**

1	LD1 Front Bumper Assembly	6	12mm Hex Nuts
1	Driver/left Frame Mounting Bracket	8	10-1.5mm x 35mm Hex Bolts
1	Passenger/right Frame Mounting Bracket	16	10mm x 27mm OD x 3mm Flat Washers
1	Driver/left Top Corner Filler Panel	8	10mm Lock Washers
1	Passenger/right Top Corner Filler Panel	8	10mm Hex Nuts
1	Driver/left "L" Bracket (center LED light)	2	8-1.25mm x 25mm Hex Bolts
1	Passenger/right "L" Bracket (center LED light)	2	8-1.25mm x 16mm Hex Bolts (LED light bar)
1	License Plate Bracket	6	8mm x 24mm Flat Washers
2	Plastic Plugs for license plate mount	4	8mm Lock Washers
6	Sensor Hole Plugs	2	8mm Hex Nuts
10	Nylon Wire Ties	6	6mm x 20mm Button Head Bolts
1	Sensor Cover Kit	4	6mm x 18mm x 1.6mm Flat Washers
3	Dodge Wire Harnesses	4	6mm x 12mm OD x 1.5mm Flat Washers
6	Sensor Retaining Clips	4	6mm Lock Washers
6	15.5mm x 25mm Centering Foam Washers	2	6mm Nylon Lock Nuts
6	12-1.75mm x 35mm Hex Bolt	1	6mm Allen Wrench
12	12mm x 32mm x 3mm Flat Washers	12	4mm x 10mm Button Head Bolts
6	12mm Lock Washers	1	4mm Allen Wrench

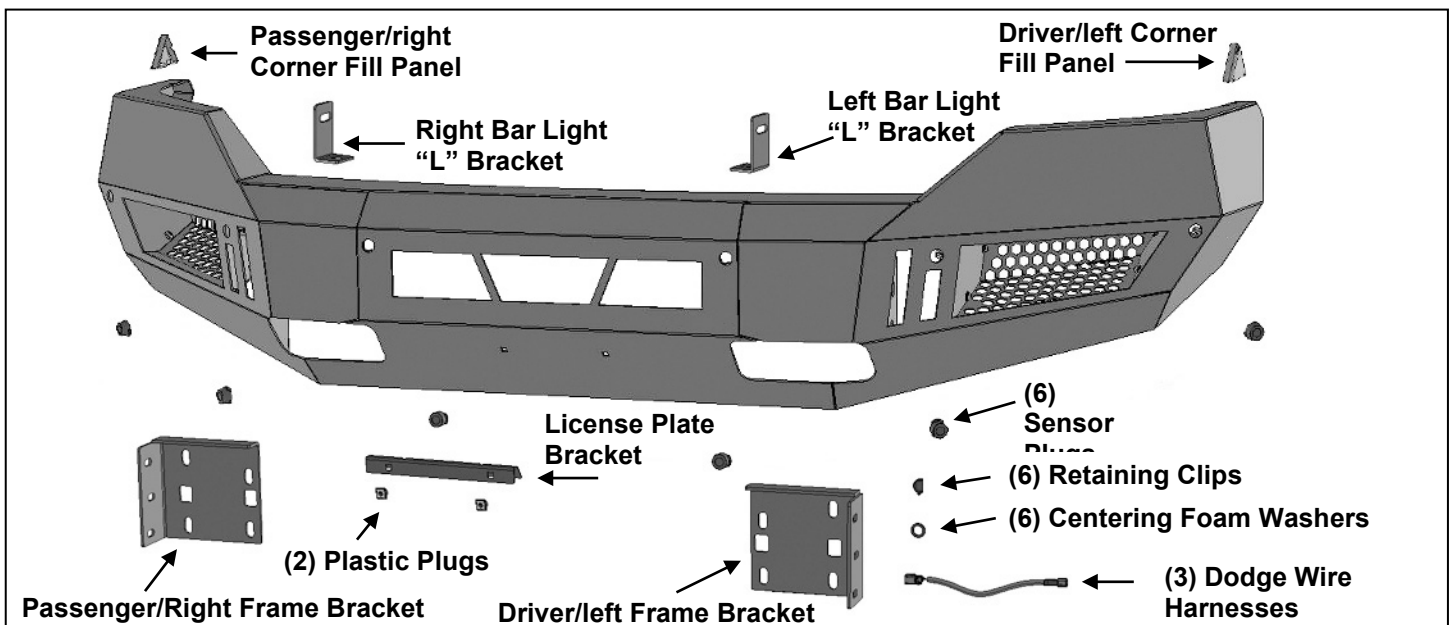
**PROCEDURE:**

**REMOVE CONTENTS FROM BOX. VERIFY ALL PARTS ARE PRESENT. READ INSTRUCTIONS CAREFULLY BEFORE STARTING INSTALLATION. BUMPER IS HEAVY, ASSISTANCE IS HIGHLY RECOMMENDED TO AVOID POSSIBLE INJURY OR DAMAGE TO THE VEHICLE. NOTE: ACCESS TO TOW HOOKS WILL BE LIMITED AFFECTING USABILITY.**

1. Remove the license plate and bracket. Remove lower air dam, (**Figure 1**). **NOTE:** Air dam is attached with many 2pc retaining clips. Pry up center of pin to release and remove clips.
2. On models with factory fog lights and/or sensors, unplug wiring harness leading to front bumper, (**Figure 2**). Release the harness from the clips and move harness out of way.
3. Next, remove the plastic fascia fill panel between the headlights and the top of the bumper. **NOTE:** Release inner fender liner to access hardware attaching the ends of fascia panel to the bottom of the front fenders, (**Figures 3 & 4**). On some model years, it may be necessary to temporarily remove the grille to remove the fascia or 1pc plastic bumper cover.

4. Place blocks or jack stands under the bumper to support it during mounting bolt removal. Once the bumper has been safely supported, remove the (3) hex nuts attaching each bumper bracket to the end of the frame, **(Figure 5)**. **WARNING!** Assistance is required to hold bumper in place during hardware removal to prevent the bumper from falling. Slide the bumper assembly off of the end of the frame.
5. Next, remove the plastic inner support blocks from the bottom of the headlights, **(Figure 6)**.
6. Select the driver/left side Frame Mounting Bracket, **(Figure 7)**. **NOTE:** Holes in mounting flange on end of frame are two sizes (3-large, 1-small). Attach the Bracket to the end of the frame with (3) 12mm x 35mm Hex Bolts, (6) 12mm Flat Washers, (3) 12mm Lock Washers and (3) 12mm Hex Nuts. Use (1) 10mm x 35mm Hex Bolt, (2) 10mm Flat Washers, (1) 10mm Lock Washer and (1) 10mm Hex Nut to attach the Bracket to the smaller, top inner mounting hole in the bumper flange, **(Figures 7 & 8)**. Repeat Step to install the passenger/right Frame Bracket.
7. Sensors must be installed in Bumper, (if equipped), before installing Bumper Assembly.

**Models without bumper sensors:**

- a. Select the included (6) Rubber Plugs.
- b. From behind bumper, push plugs into sensor mounting holes, **(Figure 9)**. Screws have been provided to lock the plugs in the sleeve. Use is optional.

**Models with bumper mounted sensors:**

- a. Disassemble factory bumper to remove the sensors and wiring harness.
- b. Select the driver/left outer sensor. Remove the factory sealing washer from the sensor. Attach (1) Centering Foam Washer, **(Figure 10)**, to the front of the sensor, **(Figure 11)**.
- c. Push the sensor in from the back of the Bumper until it is flush with the Bumper. Push (1) Retaining Clip into the sensor sleeve to secure the sensor in place, **(Figure 12)**.
- d. Repeat the previous steps for all sensors.
- e. Starting on the driver/left side, run the OE sensor wire harness through the bumper cutouts. Connect the first three driver side sensors to the OE sensor wire harness, **(Figure 13)**.
- f. Use the provided Wire Harness Extensions to connect the remaining three passenger side sensors to the OE sensor harness, **(Figure 13)**.
- g. Use the provided Wire Ties to secure the Wiring Harnesses to the back of the Bumper.
8. If front license plate is required, attach the License Plate Bracket to the holes in the bumper with the included (2) 6mm x 20mm Button Head Screws, (4) 6mm x 18mm Large Flat Washers and (2) 6mm Nylon Lock Nuts. Insert (2) Plastic Plugs into the square holes in the Bracket. Reuse the factory screws to attach the license plate to the plastic plugs, **(Figure 14)**.
9. **Center LED light installation** (sold separately). **NOTE:** It may be easier to install accessory lights before installing the Bumper, (models with tow hooks for example).
  - a. Select the L/R "L" Brackets, **(Figure 15)**. Attach the Brackets to the top of the (2) mounting tabs welded onto the back of the bumper with the included 8mm x 25mm Hex Bolts, (4) 8mm Flat Washers, (2) 8mm Lock Washers and (2) 8mm Hex Nuts. Leave loose at this time.
  - b. Attach the LED light assembly to the "L" Brackets with the included (2) 8mm x 16mm Hex Bolts, (2) 8mm Lock Washers and (2) 8mm Flat Washers. Do not fully tighten hardware at this time. **IMPORTANT:** "L" Brackets are designed for 8mm light mounting hardware only. Modify "L" Brackets if necessary or use brackets supplied by your light manufacturer if possible, to install hardware larger than 8mm.
  - c. Follow light manufacturer's instructions to properly wire light once bumper has been installed.
- LED light installation at ends of bumper** (sold separately).
  - a. Insert light into opening and up to mounting slots. Check for clearance between front and back of light. If necessary, remove screen from back of opening, **(Figure 16)**.
  - b. Follow the light manufacturer's instructions to attach (1) light to the center slot or (2) lights to the inner and outer slots in the top of the light opening, **(Figure 16)**. **IMPORTANT:** On two light systems, attach the flood light to the outer slot and the spot light to the inner slot.
  - c. Repeat the above steps for passenger side light installation.
  - d. Follow light manufacturer's instructions to properly wire light once bumper has been installed.
10. With assistance, position the LD1 Bumper assembly up to the outside of the Frame Brackets. Temporarily support the weight of the Bumper. **WARNING:** To avoid possible injury or damage to the vehicle, do not proceed until the Bumper is fully and safely supported.

11. Attach the mounting tab on the back of the driver/left side of the Bumper to the Frame Bracket with (3) 10mm x 35mm Hex Bolts, (6) 10mm Flat Washers, (3) 10mm Lock Washers and (3) 10mm Hex Nuts, **(Figures 17 & 18)**. Do not fully tighten at this time. Repeat this **Step** to attach the passenger/right side of the Bumper to the Frame Bracket.
12. Select the driver/left triangle shaped Top Corner Fill Panel, **(Figure 19)**. Attach the Panel to the top of the bumper with (2) 6mm x 20mm Button Head Screws, (2) 6mm Lock Washers and (2) 6mm x 12mm Small Flat Washers, **(Figures 19 & 20)**. **NOTE:** The driver and passenger side Top Corner Fill Panels look similar but are unique. The side of the triangle with the small notch, **(Figure 19)**, will go toward the rear, (toward the fender). Repeat to install the passenger/right Top Corner Fill Panel.
13. Level and adjust the bumper and fully tighten all hardware.
14. Do periodic inspections to the installation to make sure that all hardware is secure and tight.

**To protect your investment,** Do not use any type of polish or wax that may contain abrasives that could damage the finish. Mild soap may be used to clean the Bumper assembly.

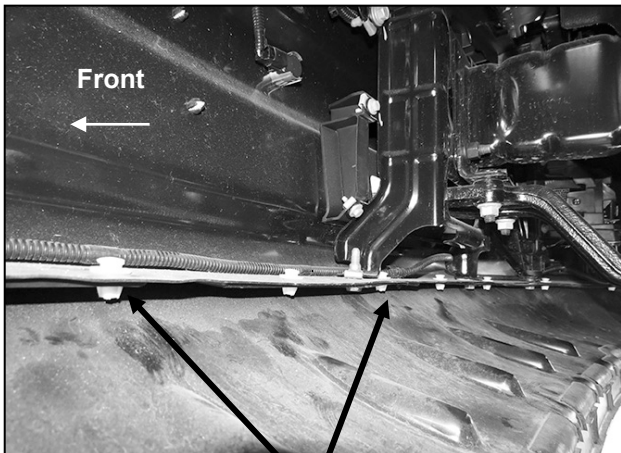

**(Fig 1) Release clips (arrow) to remove air dam (pictured from behind bumper-tow hook equipped)**



**(Fig 2) Unplug lights and sensors if equipped. Unplug harness to bumper and move harness**



**(Fig 3) Pull back fender liner to locate fascia attachment at bottom of front fender**



**(Fig 4) Remove fascia body panel from top of bumper**

### Driver Side Installation Pictured

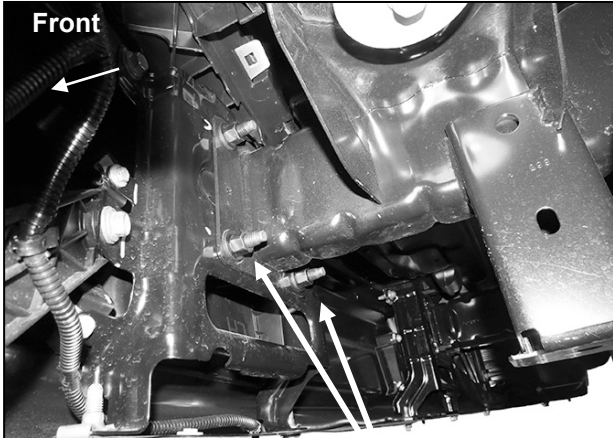

(Fig 5) Remove (3) factory hex nuts from each side

- 10mm x 35mm Hex Bolt
- (2) 10mm Flat Washers
- 10mm Lock Washer
- 10mm Hex Nut

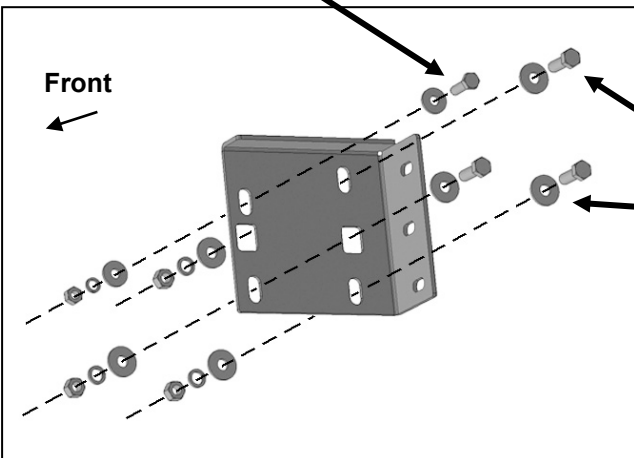

(Fig 7) Attach driver/left Bracket to end of frame

**WARNING!** Do not remove bumper bolts unless the bumper is properly supported on blocks or stands or the bumper may fall.

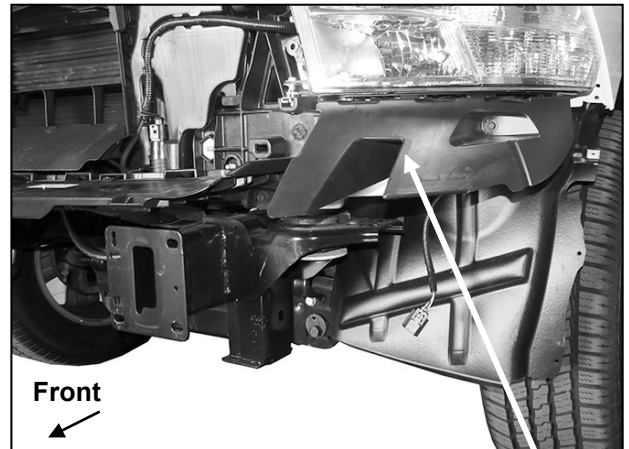

(Fig 6) Remove plastic block from below headlight

- (3) 12mm x 35mm Hex Bolts
- (6) 12mm Flat Washers
- (3) 12mm Lock Washers
- (3) 12mm Hex Nuts

- 10mm x 35mm Hex Bolt
- (2) 10mm Flat Washers
- 10mm Lock Washer
- 10mm Hex Nut

- (3) 12mm x 35mm Hex Bolts
- (6) 12mm Flat Washers
- (3) 12mm Lock Washers
- (3) 12mm Hex Nuts

**WARNING!** Do not crawl under bumper unless it is properly supported on blocks or stands or the bumper may fall.

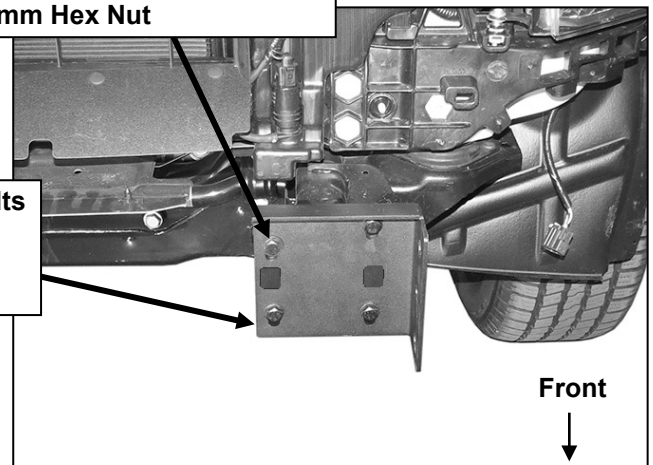

(Fig 8) Driver/left Mounting Bracket installed

### Driver Side Installation Pictured

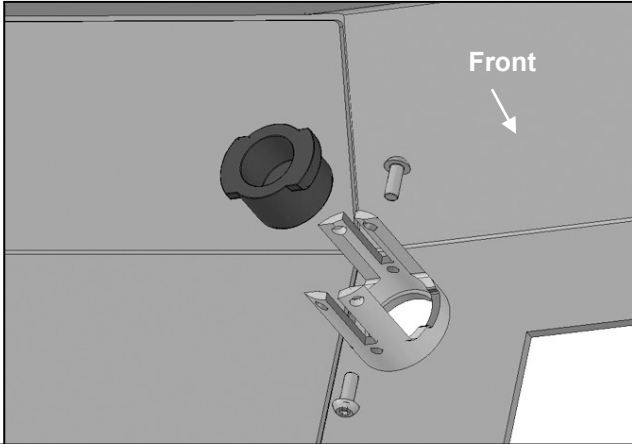

(Fig 9) Insert Plug into sleeve on back of bumper

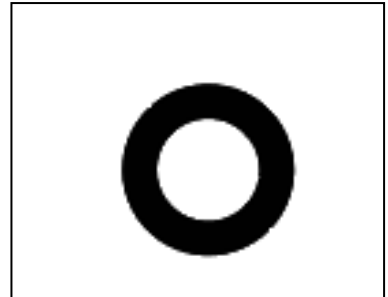

(Fig 10) Centering foam washer

Remove factory sealing washer from sensor

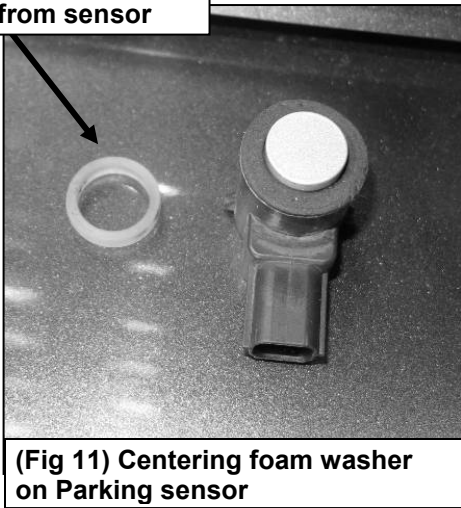

(Fig 11) Centering foam washer on Parking sensor

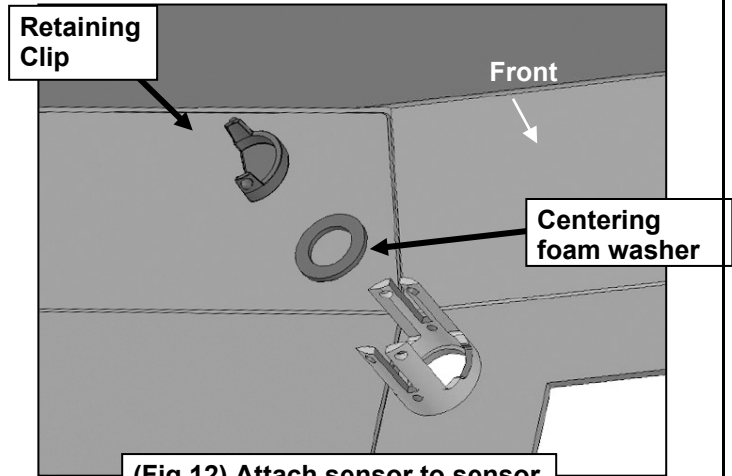

(Fig 12) Attach sensor to sensor sleeve on back of bumper

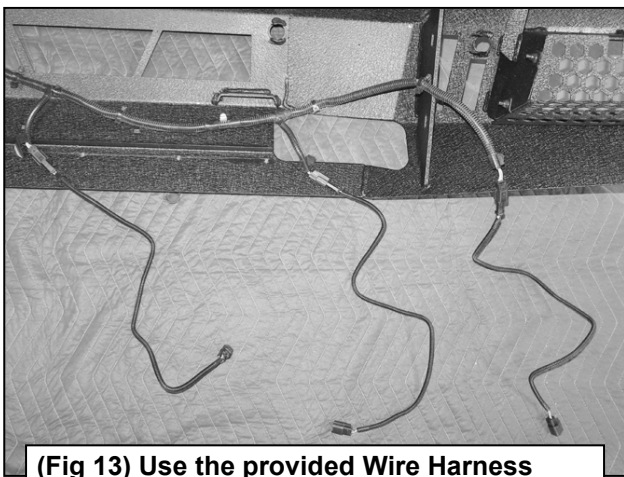

(Fig 13) Use the provided Wire Harness extensions for the Passenger side sensors

### Driver Side Installation Pictured

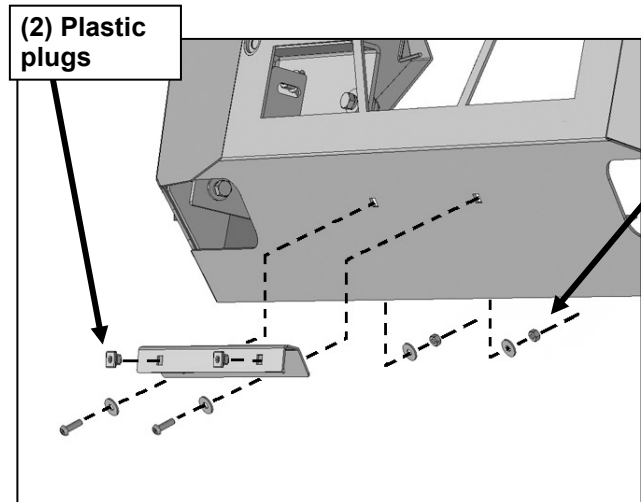

(2) Plastic plugs

(2) 6mm x 20mm Button Head Screws  
(4) 6mm Flat Washers  
(2) 6mm Nylon Lock Nuts

(Fig 14) Attach License Plate Bracket to Bumper

(2) 8mm x 25mm Hex Bolts  
(4) 8mm Flat Washers  
(2) 8mm Lock Washers  
(2) 8mm Hex Nuts

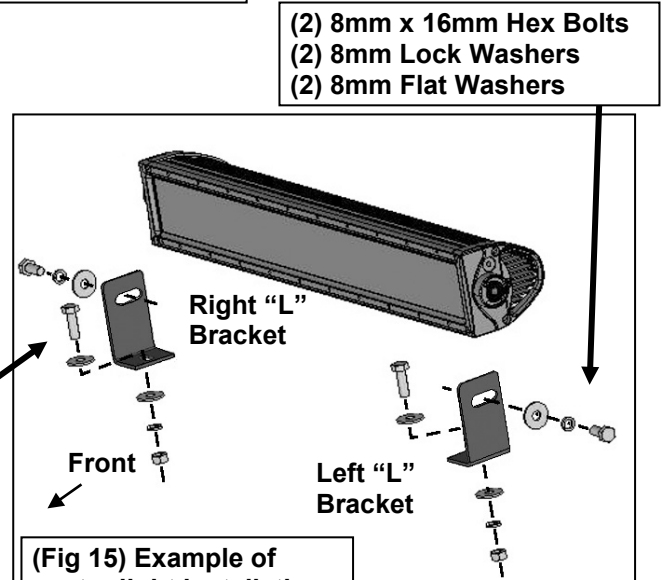

(2) 8mm x 16mm Hex Bolts  
(2) 8mm Lock Washers  
(2) 8mm Flat Washers

(Fig 15) Example of center light installation

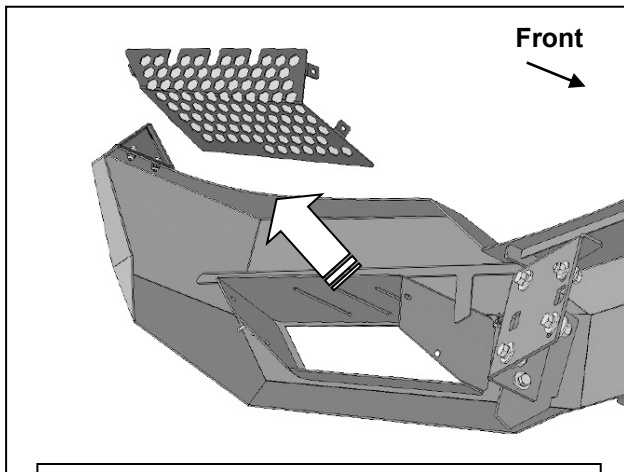

(Fig 16) Remove screens, if necessary, for clearance/access to outer light mounts

**WARNING!** Do not crawl under bumper unless it is properly supported on blocks or stands or the bumper may fall.

(3) 10mm x 35mm Hex Bolts  
(6) 10mm Flat Washers  
(3) 10mm Lock Washers  
(3) 10mm Hex Nuts

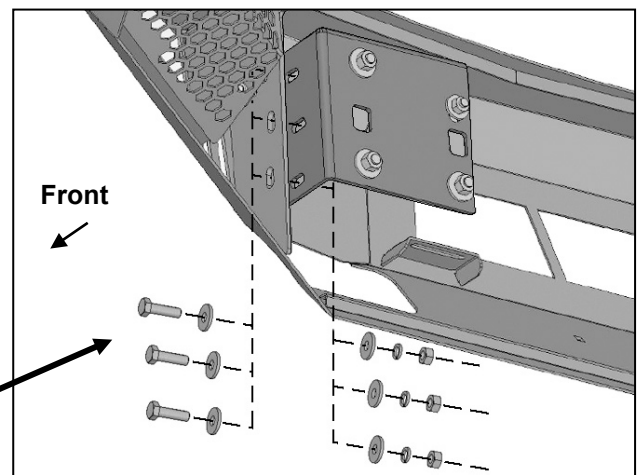

(Fig 17) Attach Bumper to Mounting Brackets

### Driver Side Installation Pictured

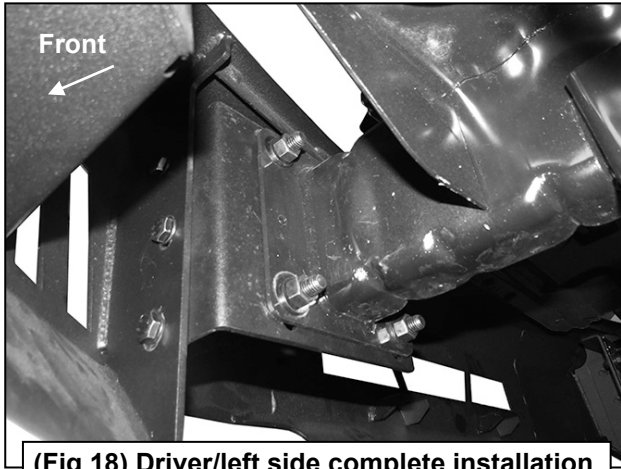

(Fig 18) Driver/left side complete installation

**WARNING!** Do not crawl under bumper unless it is properly supported on blocks or stands or the bumper may fall.

**NOTE:** Notch (arrow) designates rear of triangle Fill Panel

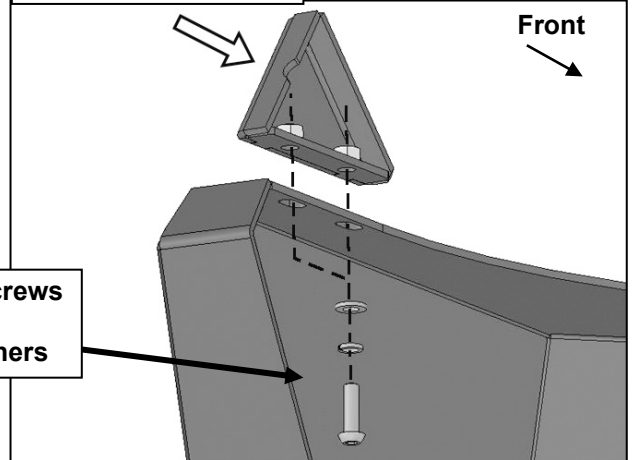

- (2) 6mm x 20mm Button Head Screws
- (2) 6mm Lock Washers
- (2) 6mm x 12mm Small Flat Washers

(Fig 19) Attach Driver/left side triangle Fill Panel to top corner of Bumper assembly



(Fig 20) Triangle Fill Panel installed



Complete Installation. Lights pictured for example only