



TUBULAR DROP STEPS

2019-2023+ 1500 QUAD CAB (EXCL. CLASSIC BODY)

INSTALLATION INSTRUCTIONS

CONTENTS

- (1) LH Side Step
- (1) RH Side Step
- (3) LH Step Brackets [DF, DC, DR]
- (3) LH Reinforcement Brackets [DF, DC, DR]
- (3) RH Step Brackets [PF, PC, PR]
- (3) RH Reinforcement Brackets [PF, PC, PR]
- (8) M8 x 25mm Hex Bolts
- (16) M8 x 16mm OD x 1.6mm Flat Washers
- (20) M8 x 24mm OD x 2mm Flat Washers
- (28) M8 Lock Nuts
- (12) M8 x 25mm Combo Bolts

TOOLS REQUIRED

- 13mm Socket/Wrench
- Ratchet

SKU # R152990

Edited: 08/29/2023

STEP 1

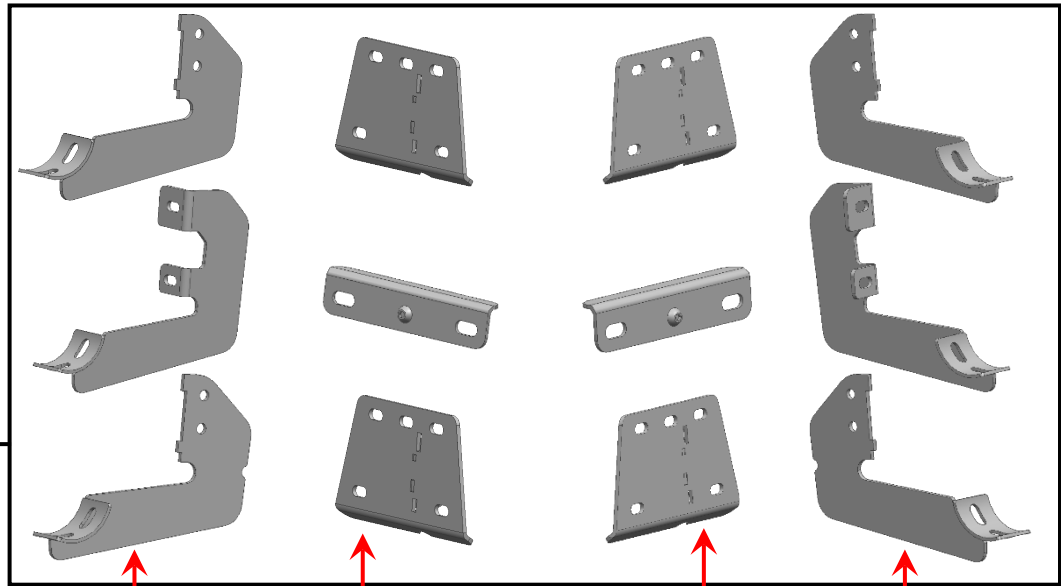

- DRIVER
STEP BRACKETS
- DRIVER
REINFORCEMENT
BRACKETS
- PASSENGER
REINFORCEMENT
BRACKETS
- PASSENGER
STEP BRACKETS

Identify each mounting bracket using the engraved location identifier. **Notice: The Front reinforcement brackets and the Rear reinforcement brackets are the same. The Rear step brackets different from the Front step brackets - a notch is cut in the rear of the Rear step bracket.**

- DF: Driver Front PF: Passenger Front
- DC: Driver Center PC: Passenger Center
- DR: Driver Rear PR: Passenger Rear

STEP 2

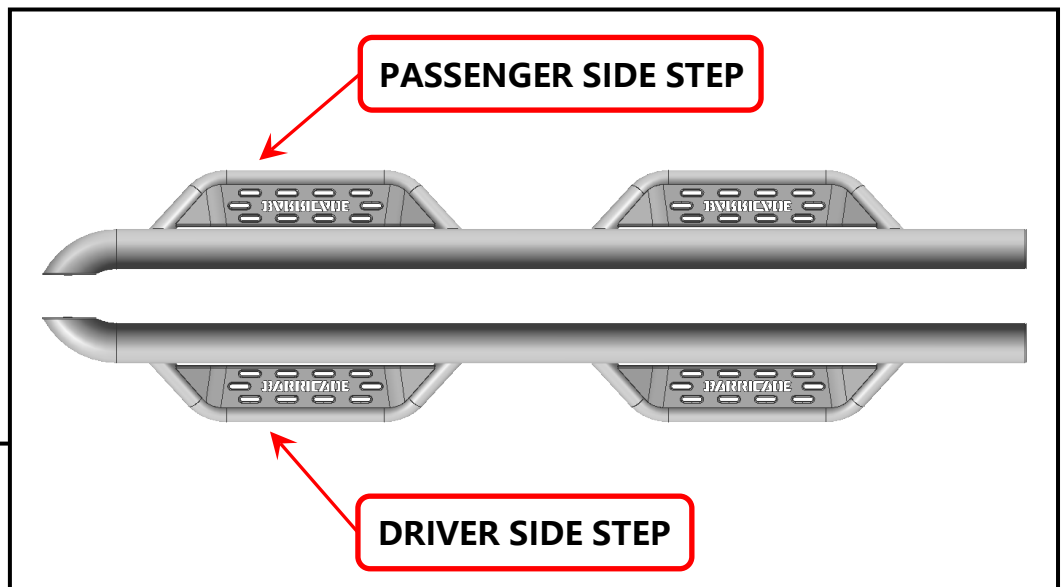

PASSENGER SIDE STEP

DRIVER SIDE STEP

Identify each side step by the curved portion of the step.

STEP 3

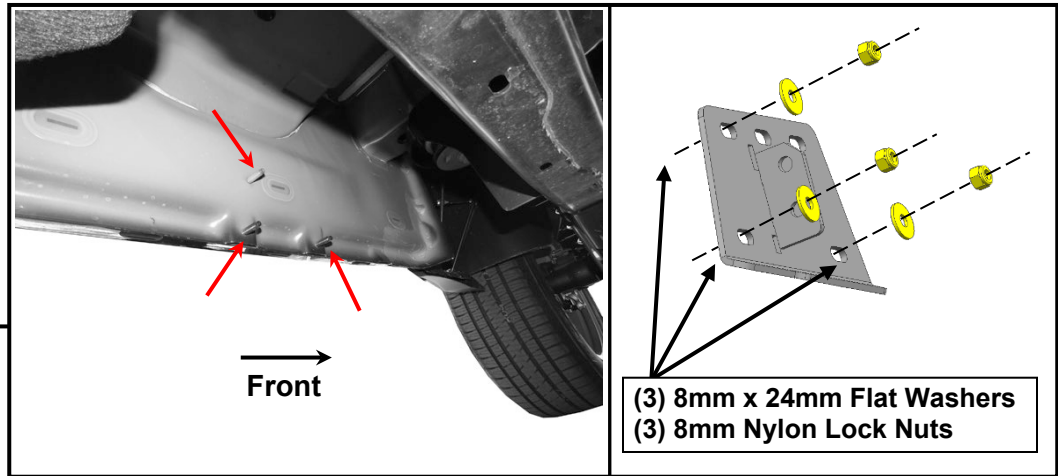

Start installation toward the front of the Driver/Left side of the vehicle.

Loosely fit the (1) Driver Front reinforcement bracket to the (3) factory studs using (3) M8 x 24mm flat washers and (3) M8 nylon lock nuts. Do not fully tighten to allow for later adjustments. Repeat this step for the Driver Rear reinforcement bracket.

STEP 4

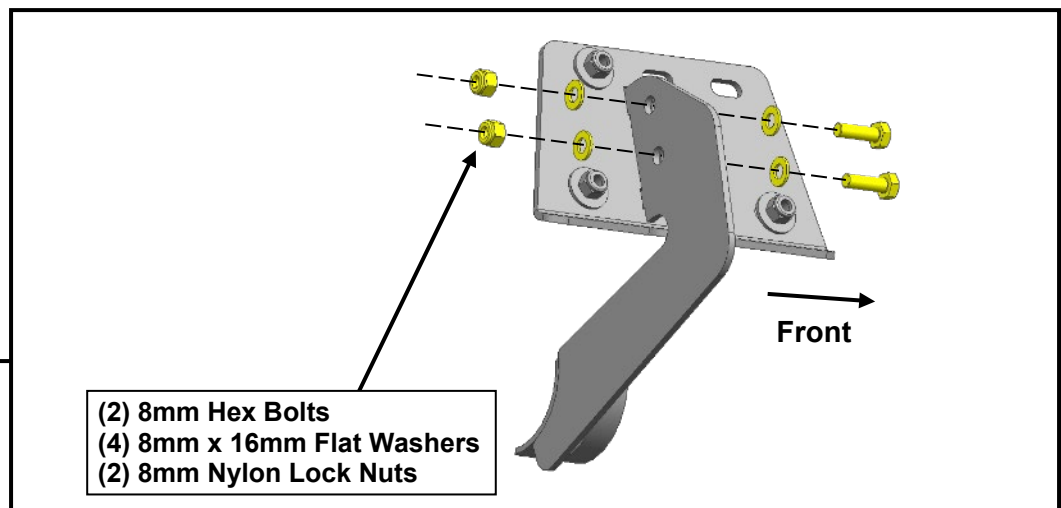

Loosely connect the (1) Driver Front step bracket to the (1) Driver Front reinforcement bracket using (2) M8 x 25mm hex bolts, (4) M8 x 16mm flat washers, and (2) M8 nylon lock nuts.

Repeat this step for the Driver Rear step bracket.

STEP 5

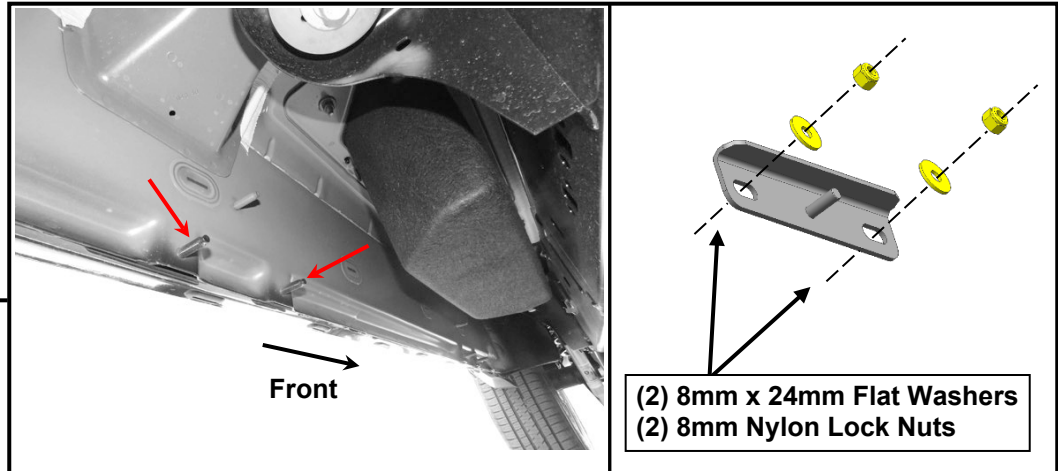

Loosely fit the (1) Driver Center reinforcement bracket to the (2) lower threaded studs using (2) M8 x 24mm flat washers, and (2) M8 nylon lock nuts. Do not fully tighten to allow for later adjustments.

STEP 6

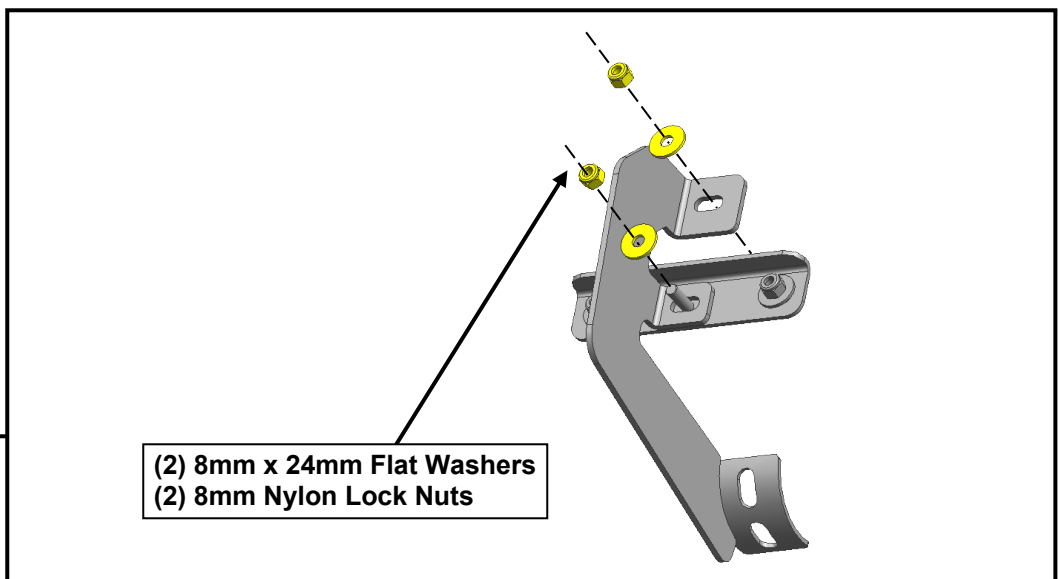

Loosely connect the (1) Driver Center step bracket to the (1) Driver Center reinforcement bracket using (2) M8 x 24mm flat washers, and (2) M8 nylon lock nut.

STEP 7

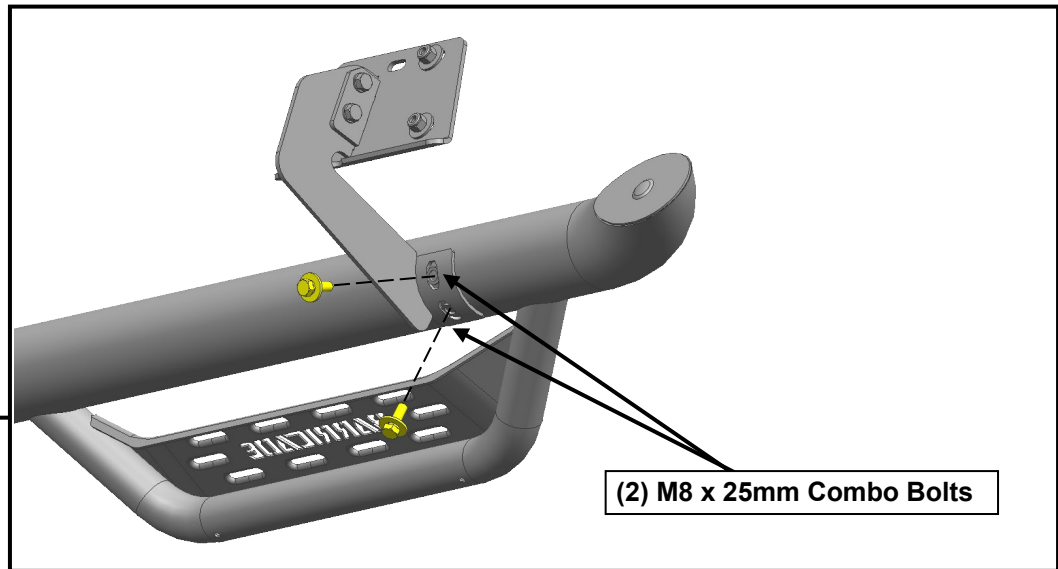

With all brackets loosely mounted to the vehicle, fit the side step onto the brackets, and loosely secure into place using (6) M8 x 25mm combo bolts.

STEP 8

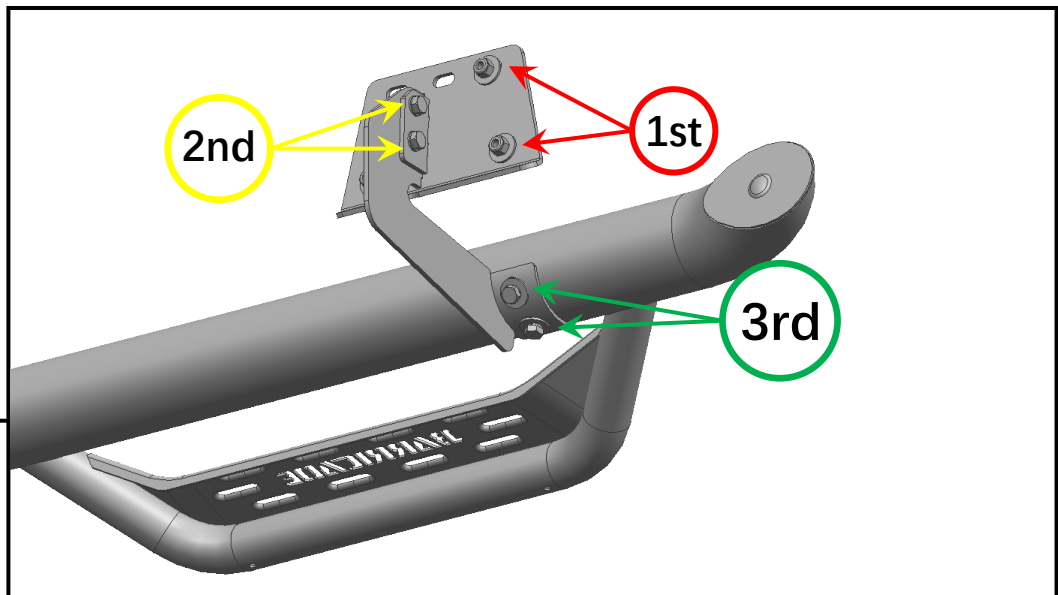

Tighten the mounting brackets to the vehicle. Adjust the side step to the desired angle, and tighten the M8 combo bolts to secure the step into place. See photo for tightening order visual.

Repeat steps 1-8 for the remaining side step.

Installation is now complete.