



---

# FORMED HD RUNNING BOARDS

2019-2025 RAM 1500 CREW CAB  
(Exclude 2019-2025 RAM 1500 Classic Crew Cab)

---

## INSTALLATION INSTRUCTIONS

---

### CONTENTS

- (1) LH Running Board
- (1) RH Running Board
- (3) LH Step Brackets [DF, DC, DR]
- (3) LH Reinforcement Brackets [DF, DC, DR]
- (3) RH Step Brackets [PF, PC, PR]
- (3) RH Reinforcement Brackets [PF, PC, PR]
- (8) M8 x 25mm Hex Bolts
- (16) M8 x 16mm OD x 1.6mm Flat Washers
- (20) M8 x 24mm OD x 2mm Flat Washers
- (28) M8 Lock Nuts
- (12) M8 x 25mm Combo Bolts

---

### TOOLS REQUIRED

13mm Wrench/Socket  
Ratchet

SKU # R178879  
Edited:09/13/2024

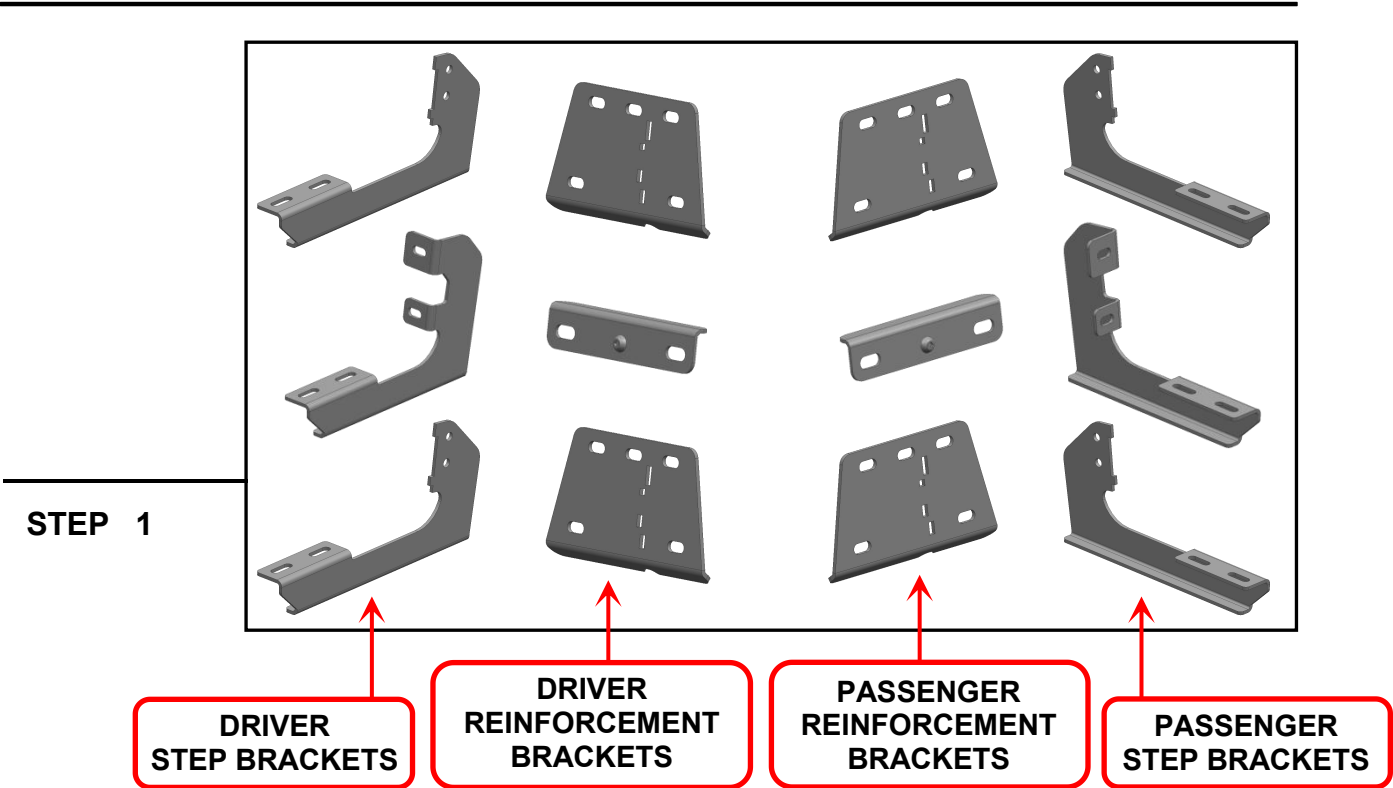

Please identify each mounting bracket using the engraved location identifier. **Notice: The 4 sets Front and Rear step brackets & reinforcement brackets are the same. The 2 sets Center step brackets & reinforcement brackets are the same.**

- |                   |                      |
|-------------------|----------------------|
| DF: Driver Front  | PF: Passenger Front  |
| DC: Driver Center | PC: Passenger Center |
| DR: Driver Rear   | PR: Passenger Rear   |

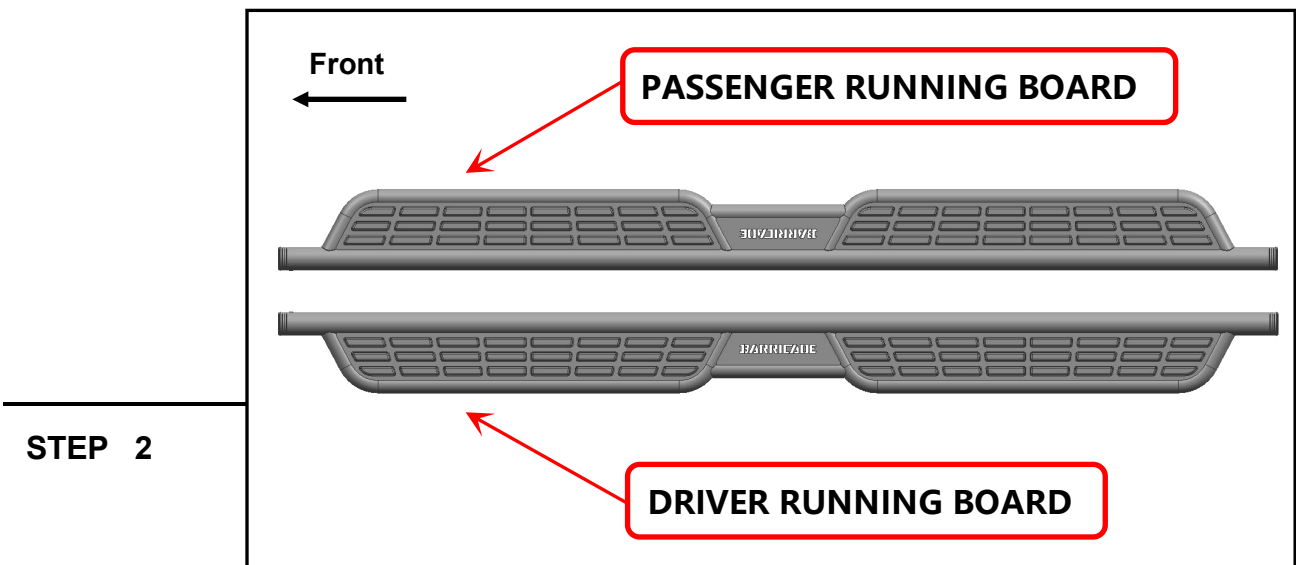

Identify each running board by identifier on the front. **Notice: "D" for Driver/Left Side; "P" for Passenger/Right Side.**

## STEP 3

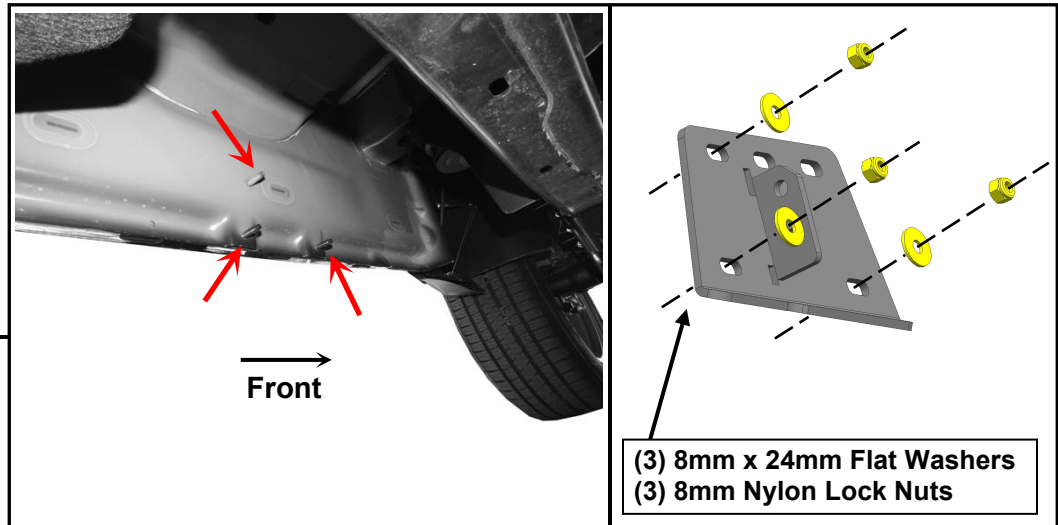

Start installation toward the front of the Driver/Left side of the vehicle.

Loosely fit the (1) Driver Front reinforcement bracket to the (3) factory studs using (3) M8 x 24mm flat Washers and (3) M8 nylon Lock Nuts. Do not fully tighten to allow for later adjustments. Repeat this step for the Driver Rear reinforcement bracket.

## STEP 4

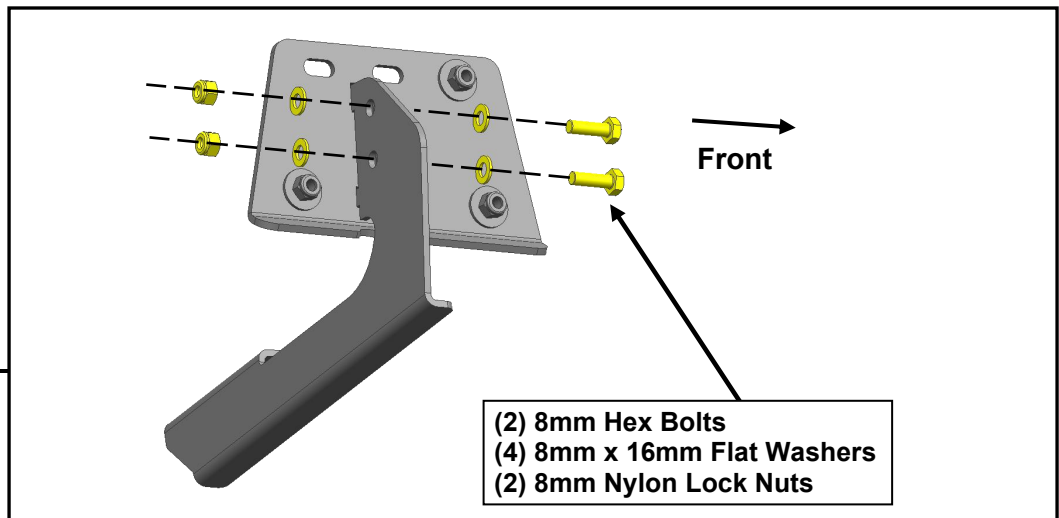

Loosely connect the (1) Driver Front step bracket to the (1) Driver Front reinforcement bracket using (2) M8 x 25mm hex bolts, (4) M8 x 16mm flat washers, and (2) M8 nylon lock nuts.

Repeat this step for the Driver Rear step bracket.

## STEP 5

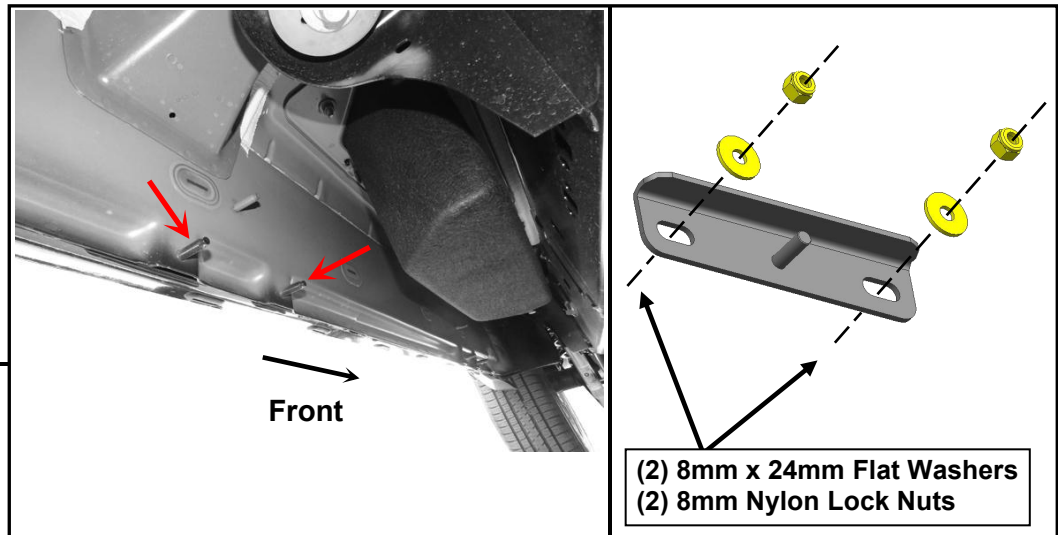

Loosely fit the (1) Driver Center reinforcement bracket to the (2) lower threaded studs using (2) M8 × 24mm flat washers, and (2) M8 nylon lock nuts. Do not fully tighten to allow for later adjustments.

## STEP 6

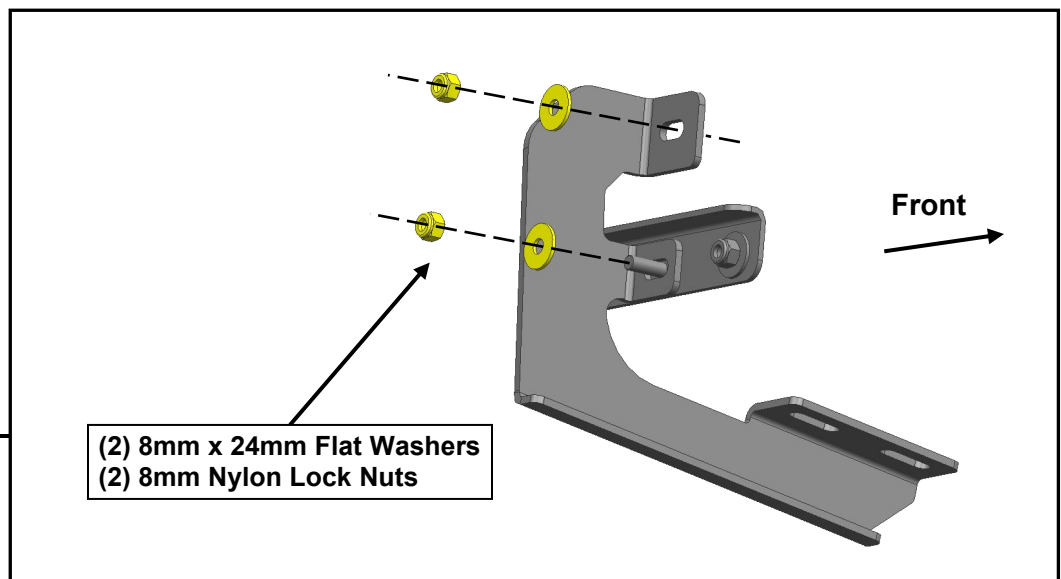

Loosely connect the (1) Driver Center step bracket to the (1) Driver Center reinforcement bracket using (2) M8 × 24mm flat washers, and (2) M8 nylon lock nut.

## STEP 7

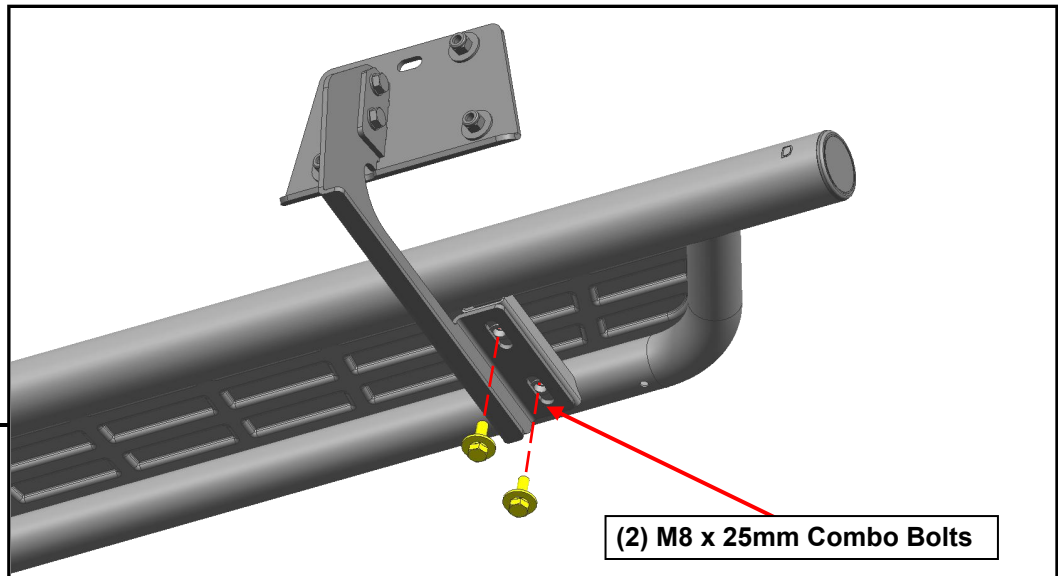

With all brackets loosely mounted to the vehicle, fit the running board onto the brackets, and loosely secure into place using (6) M8 x 25mm combo bolts.

## STEP 8

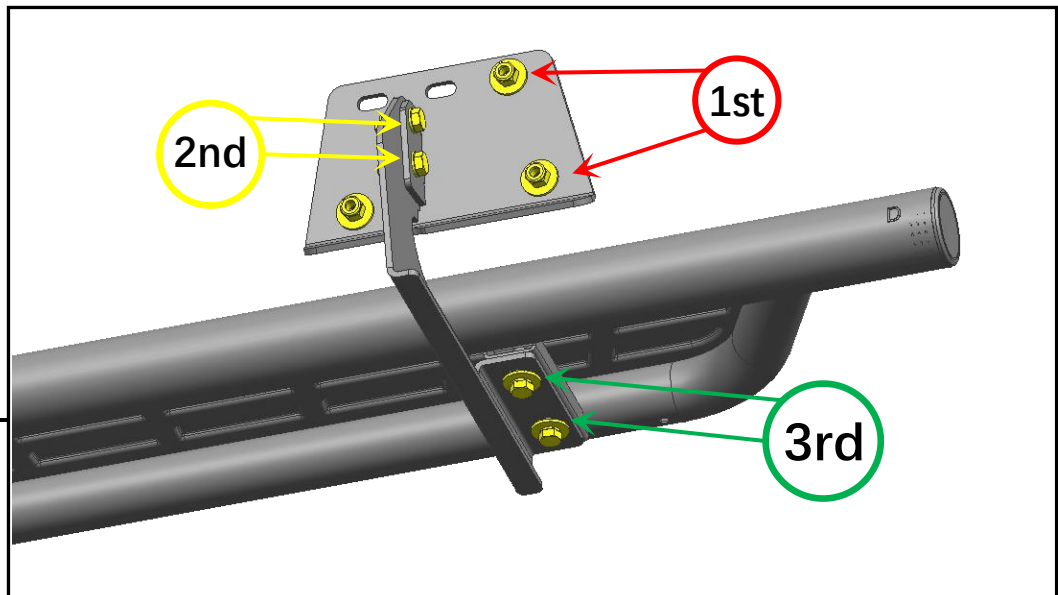

Tighten the mounting brackets to the vehicle. Adjust the running board to the desired angle, and tighten the M8 combo bolts to secure the step into place. See photo for tightening order visual.

Repeat steps 1-8 for the remaining running board.

Installation is now complete.