

## ***advanced FLOW engineering***

Cold Air Intake System

**Instruction Manual** P/N: 57-10032D / 57-10032K / 57-10032KR

Make: RAM

Model: 1500 RHO

Year: 2025-2026

Engine: L6-3.0L(tt) Hurricane



- Please read the entire instruction manual before proceeding.
- Ensure all components listed are present.
- For technical support please call at 951-493-7185.
- Ensure you have all necessary tools before proceeding.
- Do not attempt to work on your vehicle when the engine is hot.
- Retain factory parts for future use.

Label	Qty.	Description	Part Number
A	1	Air Filter (Pro DRY S) for 57-10032D	24-91205D
A	1	Air Filter (Black Pro 5R) for 57-10032K and 57-10032KR	24-91205K
B	1	Tube, Carbon Fiber for 57-10032D and 57-10032K	05-5710032C1
B	1	Tube, Carbon Fiber W/ Red Kevlar for 57-10032KR	05-5710032R1
C	1	Housing	05-5710032B2
D	1	Coupler, Silicone Hump: 4"ID x 2-1/2"L	05-01399
E	1	Plug, for housing auxiliary inlet	05-01769
F	1	Bracket, Engine Cover support (Black)	05-01808
G	2	Worm Clamp, #064 (Black)	03-50006B
H	1	Worm Clamp, #096 (Black)	03-50003B
J	2	Screw, Torx: M4 x 8mm	03-50491
K	2	Cable holder for 7/16" Diameter	05-01770
M	1	Adel Clamp, With Neoprene Cushion	05-01811
N	1	Nut, Hex Nylon Lock: M6 x 1.0	03-50185
P	1	Washer, M6 Fender, (Black)	03-50810
Q	1	Screw, Hex Head: M6 x 1.0 x 16 (Black)	03-50812

**Installation will require the following tools:**

8mm nut drivers or socket, 10mm,13mm sockets and ratchet, 6" extension, and T20 torx bit, Adjustable wrench.

Warranty information available at <https://afepower.com/warranty>

**Emissions Disclaimer:**

This product is not currently CARB exempt and is not available for purchase in California or for use on any vehicle registered with the California Department of Motor Vehicles.

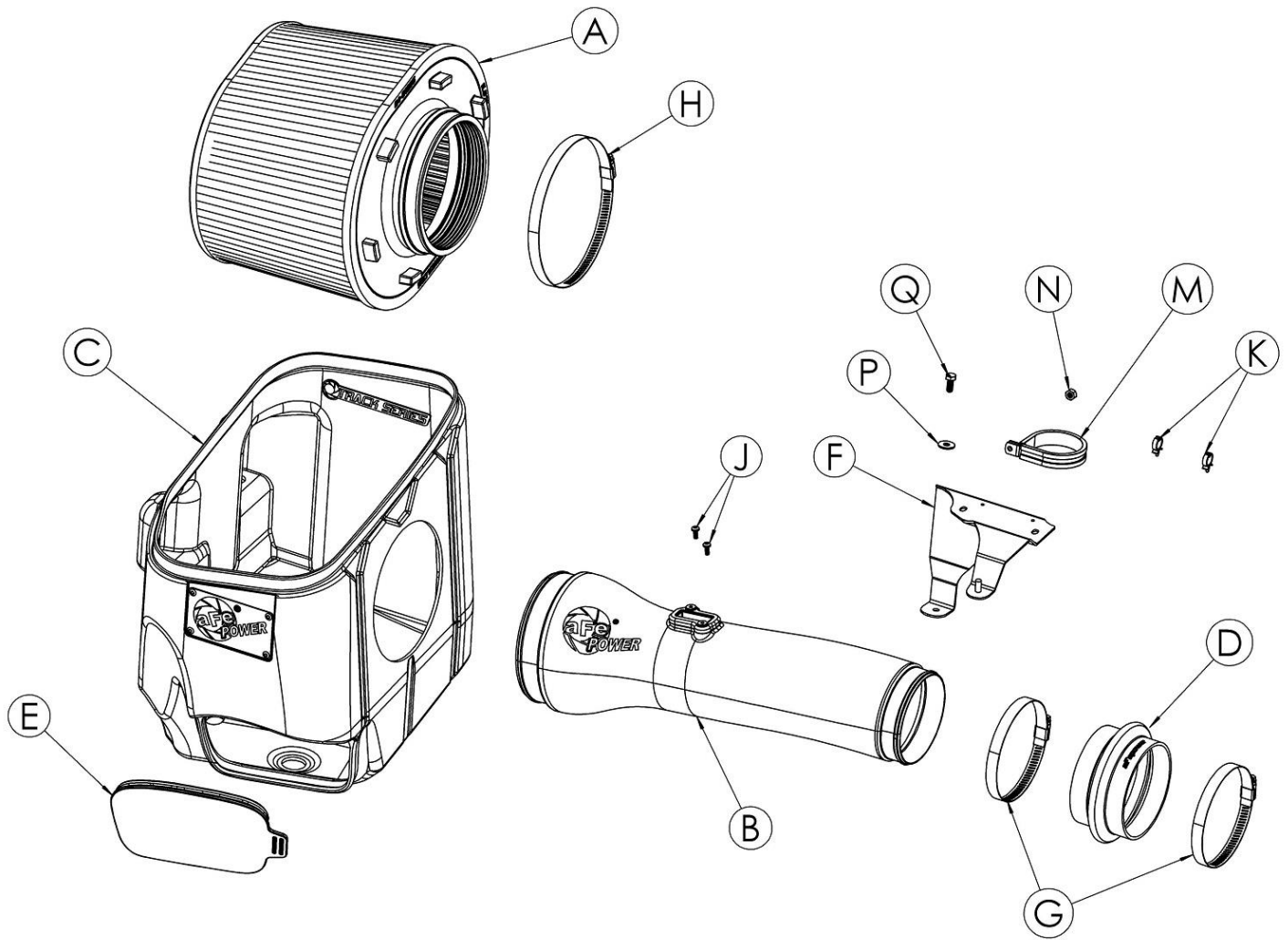



**Figure A**

**Refer to Figure A for Steps 1-2**

Step 1: Using a 13mm socket and ratchet, remove the nut securing the engine cover.

Step 2: Remove the engine cover.

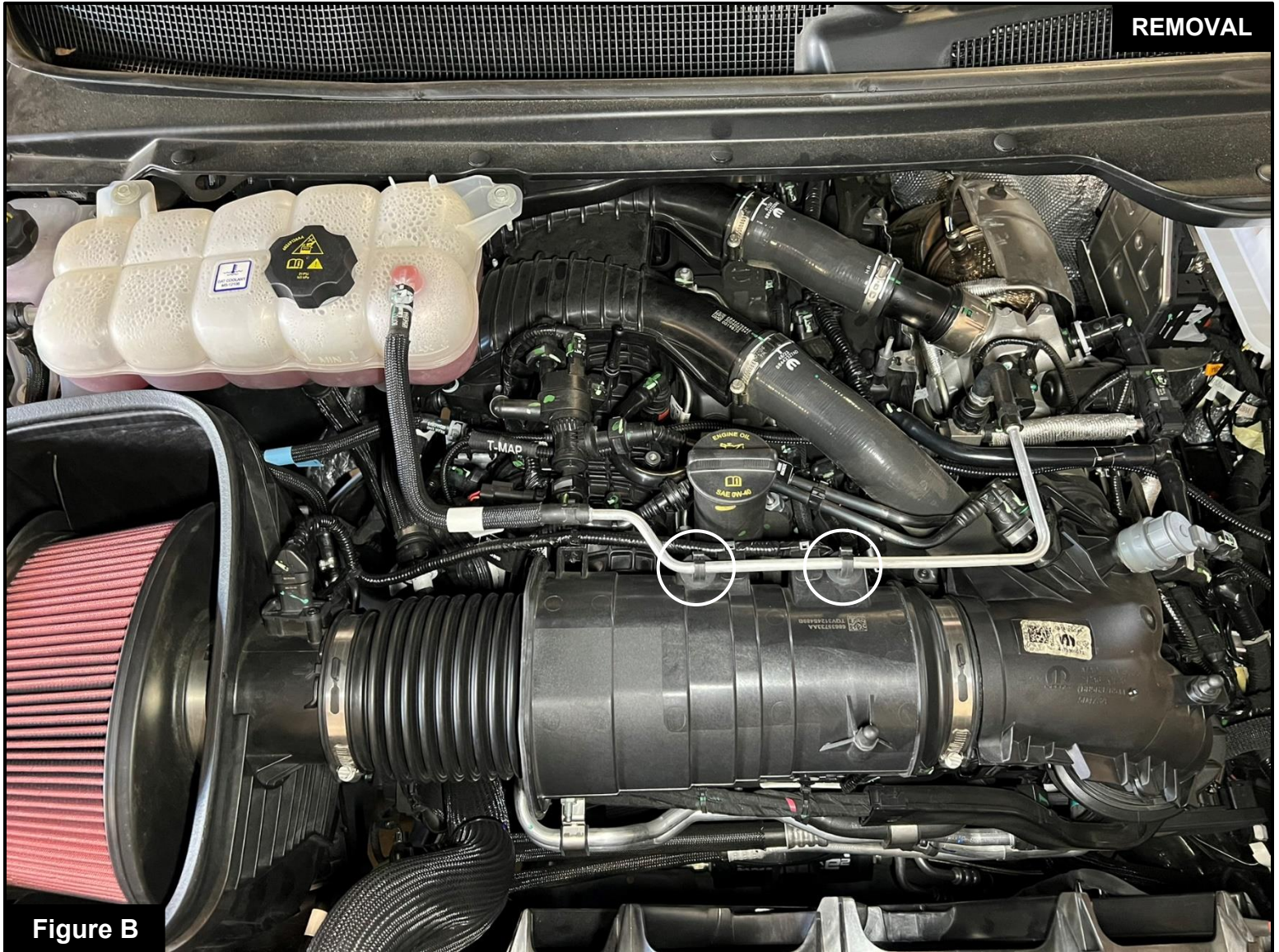

Figure B

**Refer to Figure B for Step 3**

Step 3: Carefully release the coolant line from the retaining clips along the air intake tube path. Gently tuck the line behind the oil filler neck to keep it out of the way during the installation process.

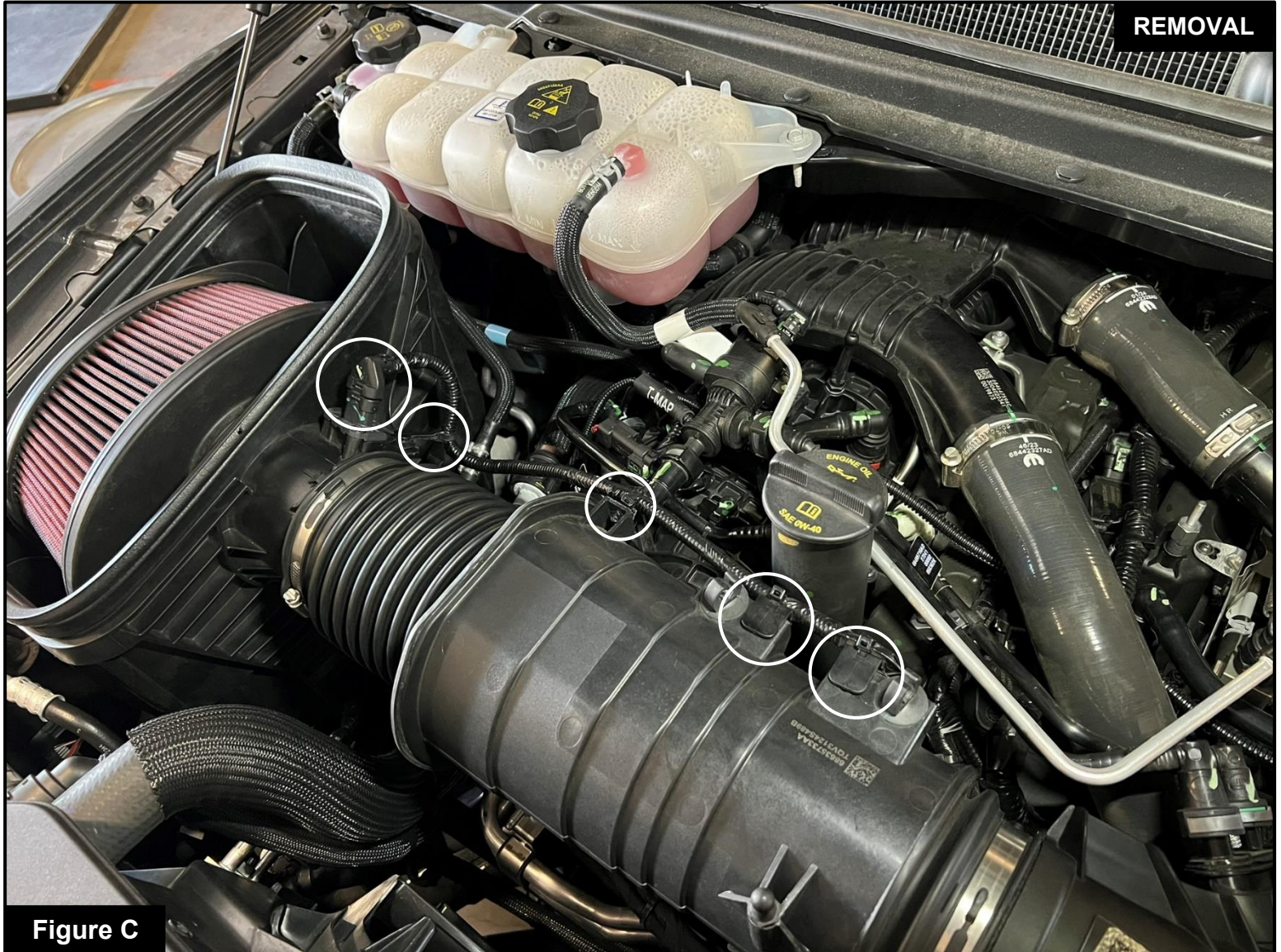
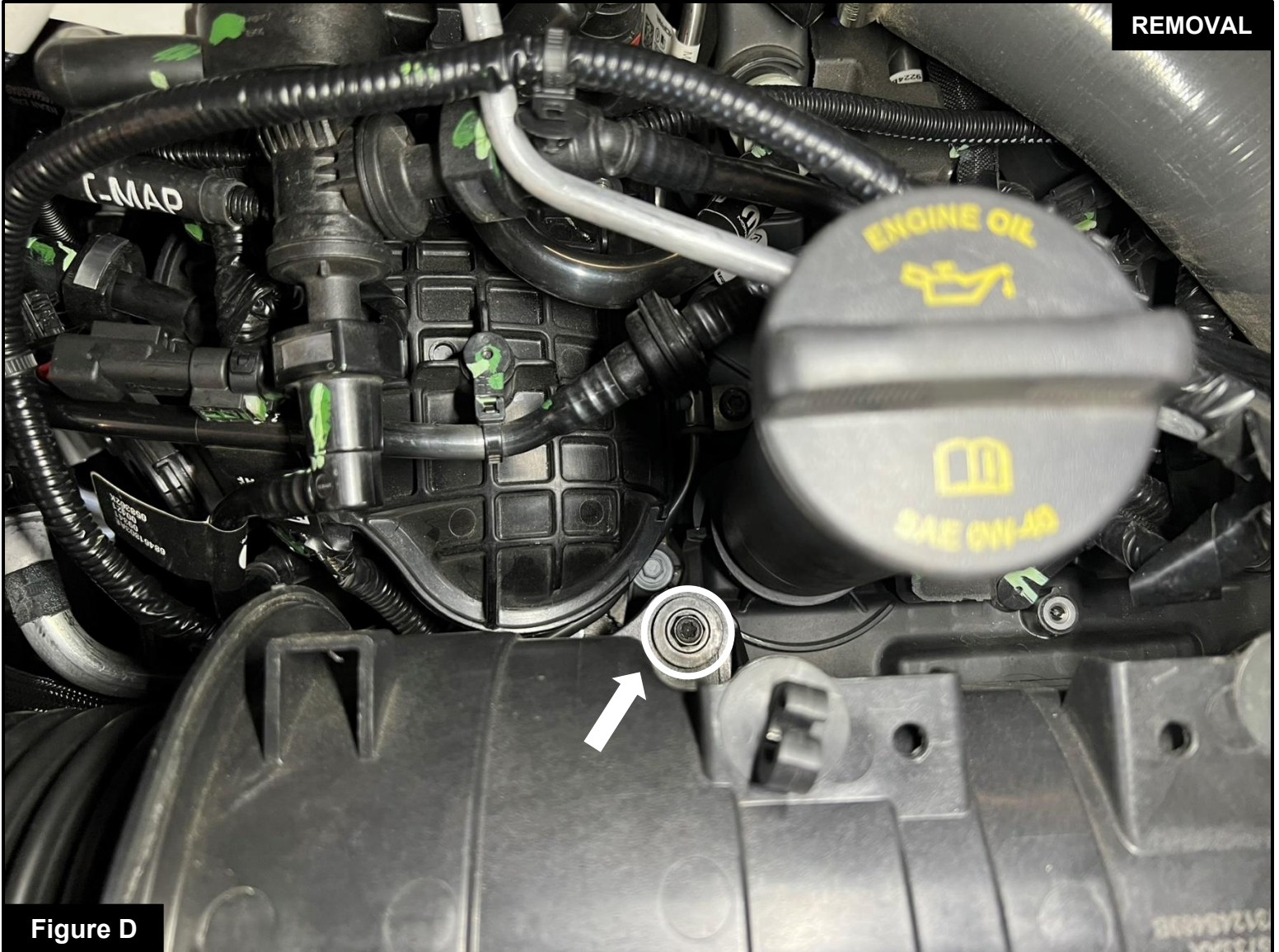

Figure C

**Refer to Figure C for Steps 4-5**

Step 4: With a plastic pry tool or trim removal tool, gently pop out the four retaining clips that hold the Mass Air Flow (MAF) sensor harness in place, tuck the harness behind the oil filler neck to keep it out of the way. Be careful not to damage the wiring.

Step 5: Push the locking clip outward, then press down on the release tab to disconnect the MAF sensor connector.

**Figure D****Refer to Figure D for Step 6**

Step 6: Using a 10mm socket with an extension and a ratchet, remove the screw securing the intake tube to the vehicle.

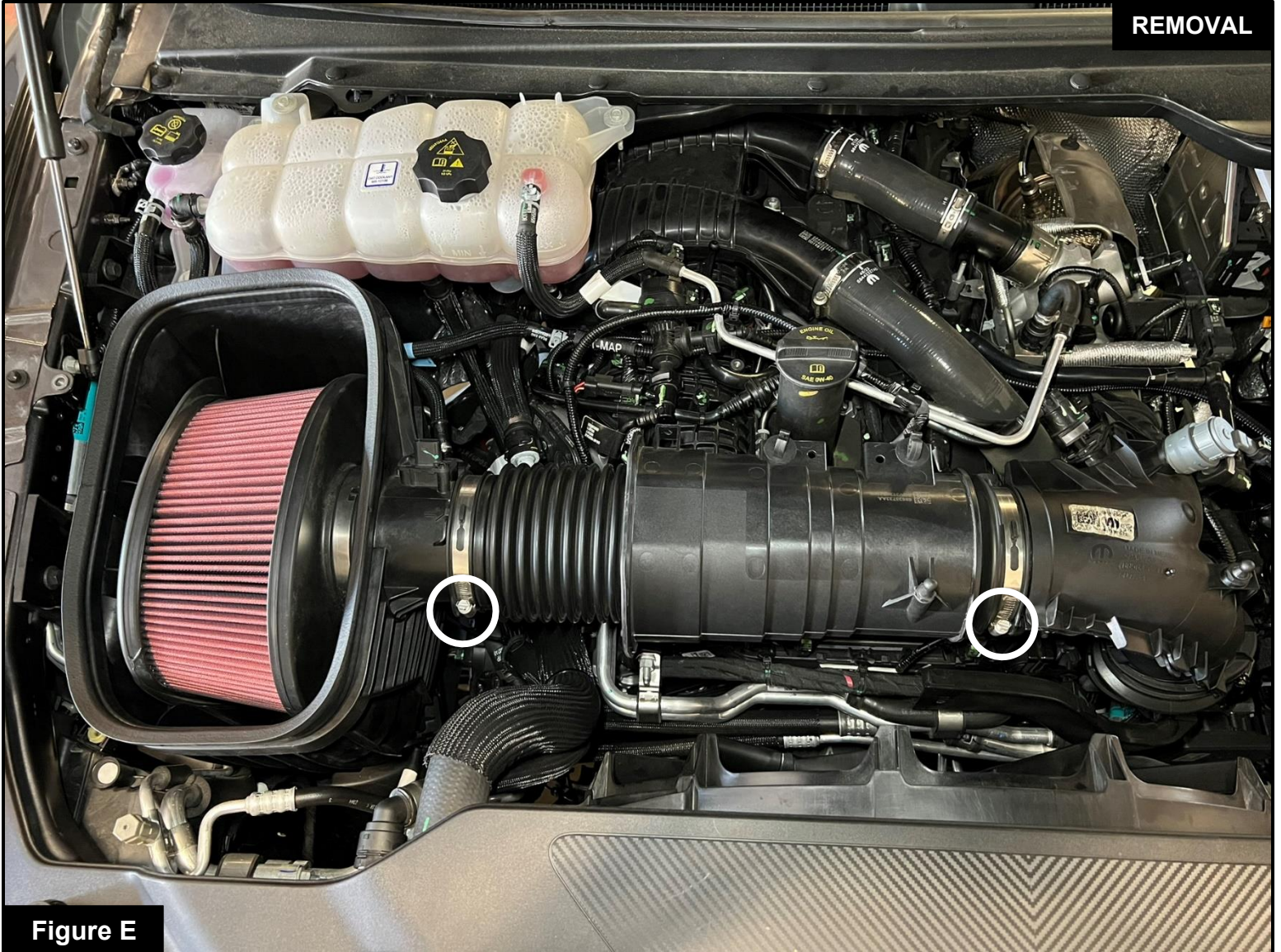
**Figure E****Refer to Figure E for Step 7**

Step 7: Using an 8mm nut driver, loosen the clamps securing the intake tube to the turbo inlet tube and airbox. Once loosened, carefully remove the intake tube by sliding it off both sides.

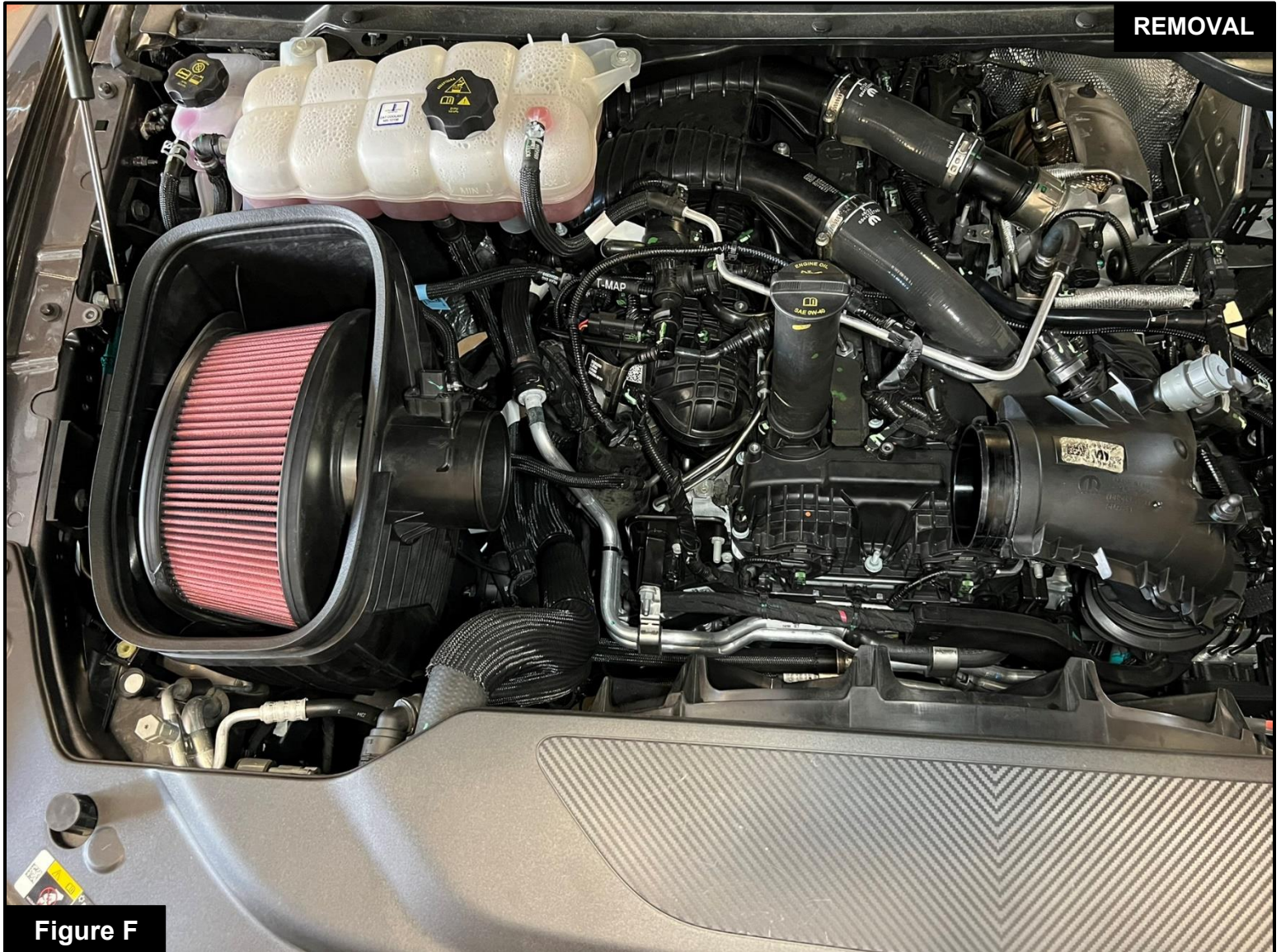

**Refer to Figure F for Step 8**

Step 8: Firmly grasp the airbox and pull straight up to release the grommets from the mounting pegs. Lift the airbox out of the vehicle.



**Figure G**

**Refer to Figure G for Step 9**

Step 9: Remove the factory mounting peg by using 12mm deep socket. It will be used at a later time during this installation.



**Figure H**

**Refer to Figure H for Steps 10-11**

Step 10: Transfer the (5) five factory grommets from the bottom of the factory airbox to the Track Series housing.

Step 11: Transfer the drain plug as well.



**Refer to Figure I for Step 12**

Step 12: Transfer the factory seal trim from the factory airbox to the Track Series housing.



Figure I

**Refer to Figure I for Step 13**

Step 13: Install the provided silicone plug into the front inlet of the Track Series housing.



Figure J

**Refer to Figure J for Step 14**

Step 14: Install the aFe POWER housing assembly into the vehicle, aligning the grommets on the housing with the factory mounting pegs. Press down firmly to sit the housing securely.



**Refer to Figure K for Step 15**

Step 15: Remove the air filter clamp from the aFe POWER air filter. Slide the air filter into the aFe POWER housing from the top opening. Then guide the filter flange through the round opening in the housing and snap in the air filter. Orient the air filter as shown on the picture. Place the provided black clamp onto the air filter flange but do not tighten at this time.



Figure L

**Refer to Figure L for Step 16**

Step 16: Transfer the Mass Air Flow (MAF) sensor from the factory housing to the Track Series intake tube. Secure it with the provided black screws using a T20 Torx bit or driver.

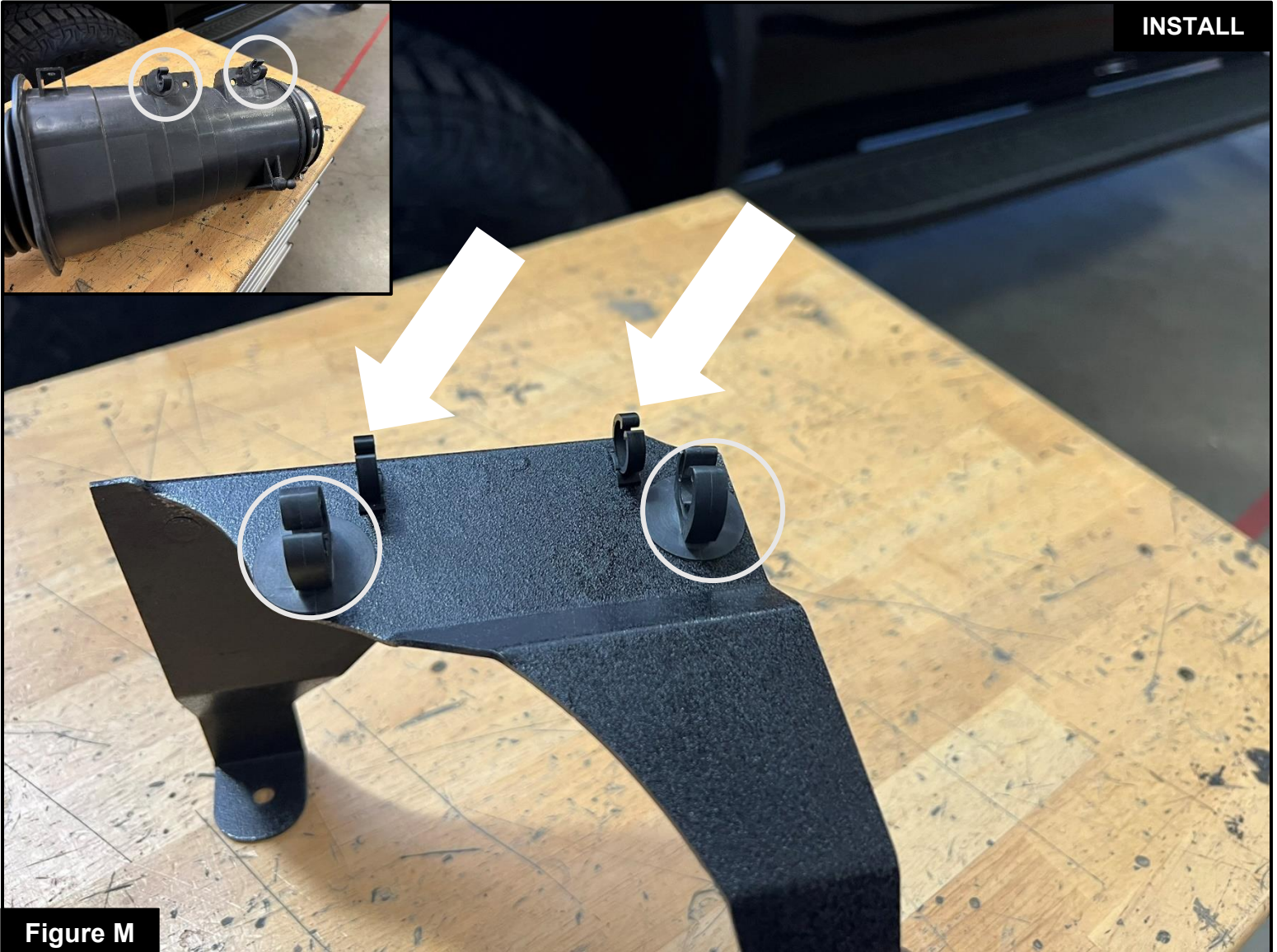
**Figure M****Refer to Figure M for Steps 17-18**

- Step 17: Remove the coolant line clips from the factory tube and install them on the aFe POWER bracket.
- Step 18: Install the cable holder clips provided into the small holes on the aFe POWER bracket, they will be used to secure the wiring harness.

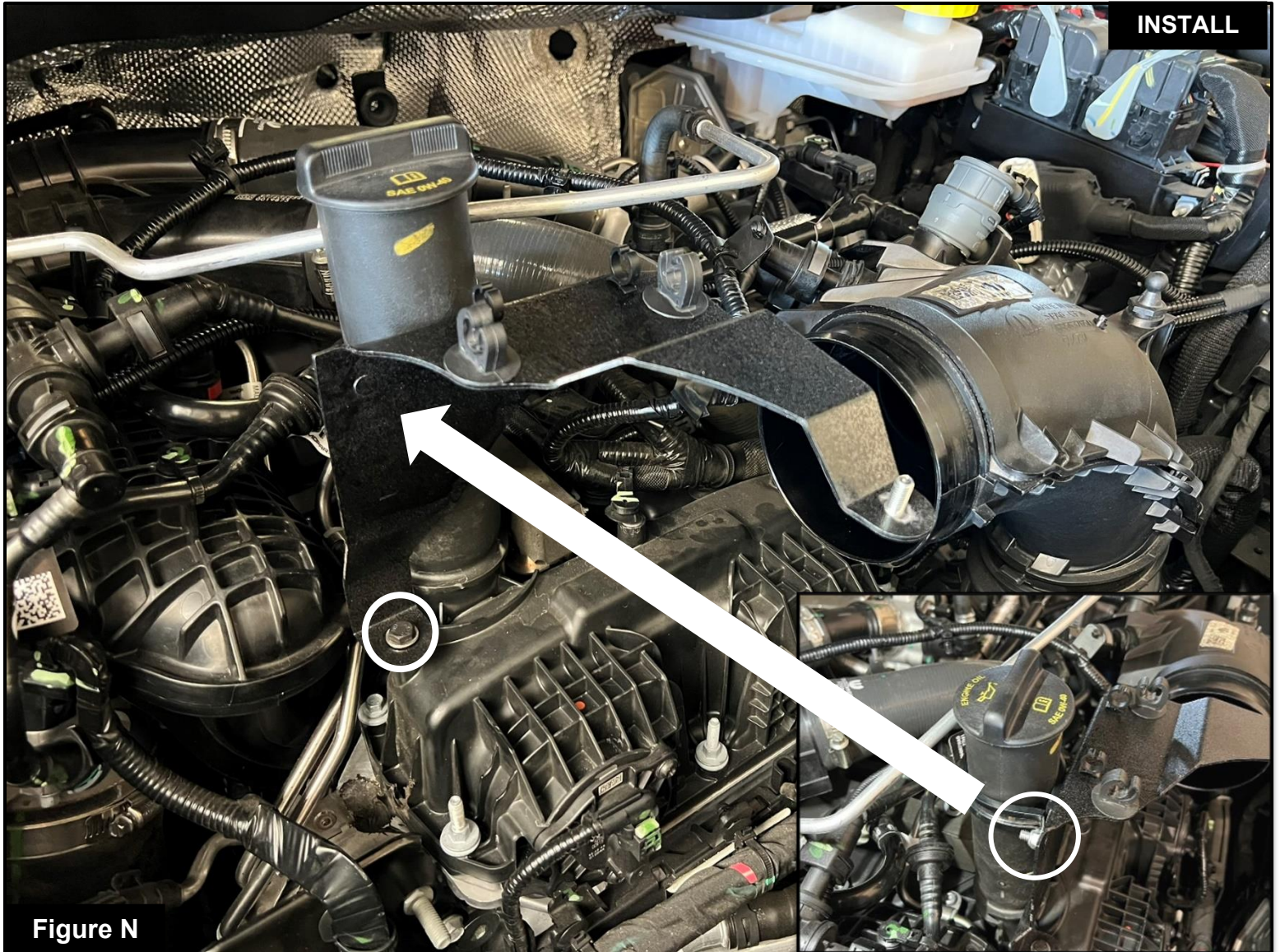

Figure N

**Refer to Figure N for Step 19-20**

Step 19: Install the provided M6 bolt and washer to secure the the bracket to the engine mount.

Step 20: Place the Adel clamp around the oil filler neck, then place over the stud on the bracket and secure it with the provided M6 nut.



**Figure O**

**Refer to Figure O for Step 21**

Step 21: Install the factory peg that was removed in step 9 onto the stud on the bracket.

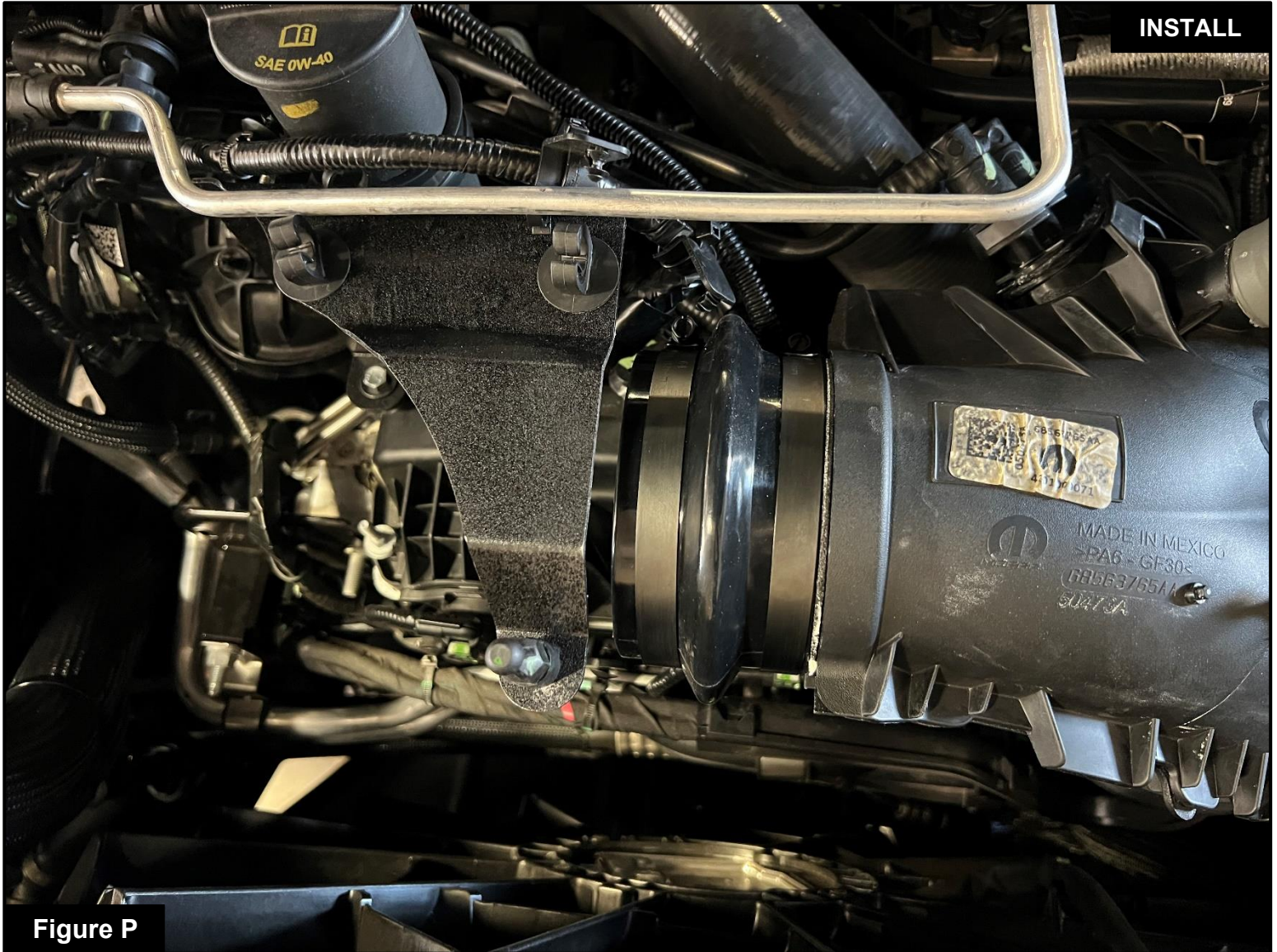

**Figure P**

**Refer to Figure P for Step 22**

Step 22: Pre-Install the clamps onto the coupler and then install the coupler onto the turbo inlet. Do not tighten at this time.

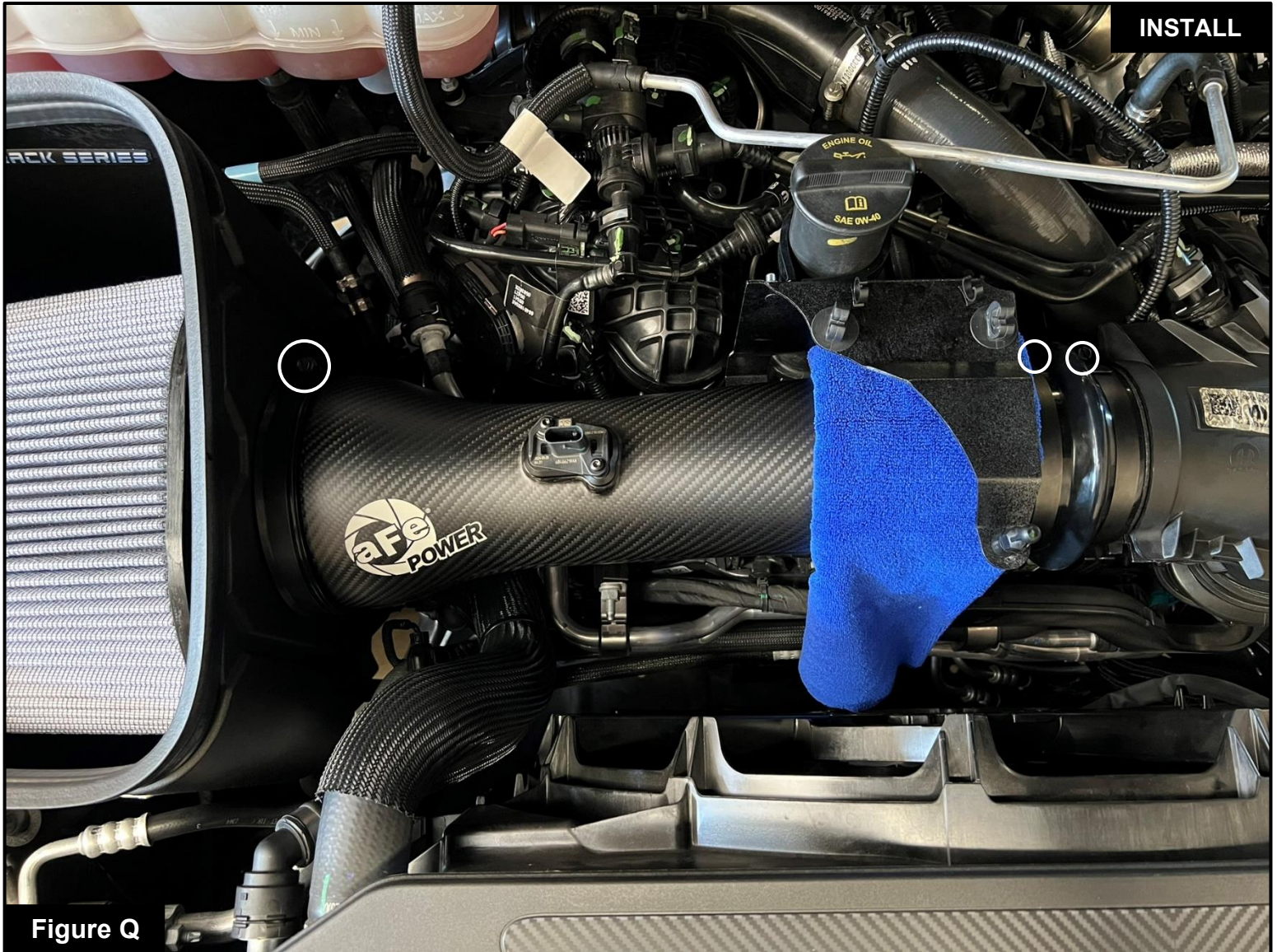

Figure Q

**Refer to Figure Q for Steps 23-24**

Step 23: Slide the track series tube into the coupler first and then into the filter. We recommend using a microfiber towel to prevent any damage that may happen when installing the tube around the bracket.

Step 24: Make sure the sensor is facing up, then tighten all (3) three clamps at this time.

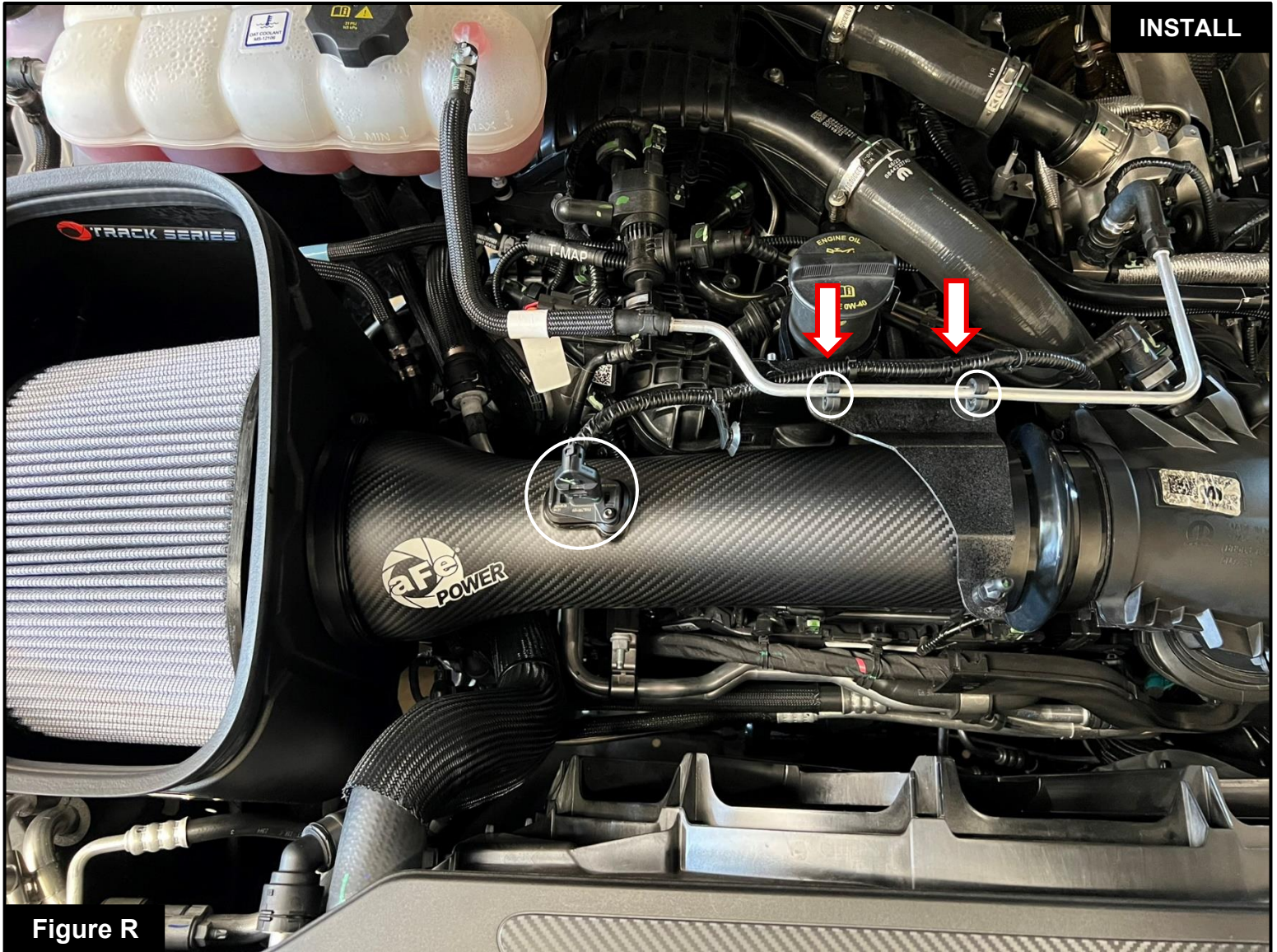

Figure R

**Refer to Figure R for Steps 25-26**

Step 25: Clip the MAF sensor harness onto the clips, then plug in the MAF sensor.

Step 26: Clip on the coolant lines onto the clips on the bracket.



**Figure S**

**Refer to Figure S for Step 27**

Step 27: Re-install the engine cover by securing it onto the peg on the bracket then using the nut that was removed on **Step 1**.

**Your installation is now complete. Thank you for choosing aFe POWER!**

**NOTE: Check to ensure that all screws, clamps, and connectors are secure after 100-200 miles.**



***advanced FLOW engineering, inc.***

Corona, CA 92879

<https://afepower.com/contact>