



Rocker Step

PART #: BR-DRS-011

FITS: 2019-Up Dodge RAM 1500 Crew Cab
(Exclude 2019-2024 RAM 1500 **Classic** Crew Cab)



60-120 min



Cutting Not Required



Drilling Not Required

Torque & Tools

Fastener Size	Tightening Torque (ft-lbs)	Wrench Required		Allen Wrench Required	
			<input type="checkbox"/> 10mm		<input type="checkbox"/> 4mm
<input checked="" type="checkbox"/> 8mm	<input checked="" type="checkbox"/> 18-20		<input checked="" type="checkbox"/> 13mm		<input type="checkbox"/> 5mm
<input type="checkbox"/> 10mm	<input type="checkbox"/> 35-40		<input type="checkbox"/> 16mm		<input type="checkbox"/> 6mm
<input type="checkbox"/> 12mm	<input type="checkbox"/> 60-70		<input type="checkbox"/> 18mm		<input type="checkbox"/> 8mm

BEFORE INSTALLATION

REMOVE CONTENTS FROM BOX. VERIFY ALL PARTS ARE PRESENT. READ INSTRUCTIONS CAREFULLY BEFORE STARTING INSTALLATION. ASSISTANCE IS RECOMMENDED.

Part List

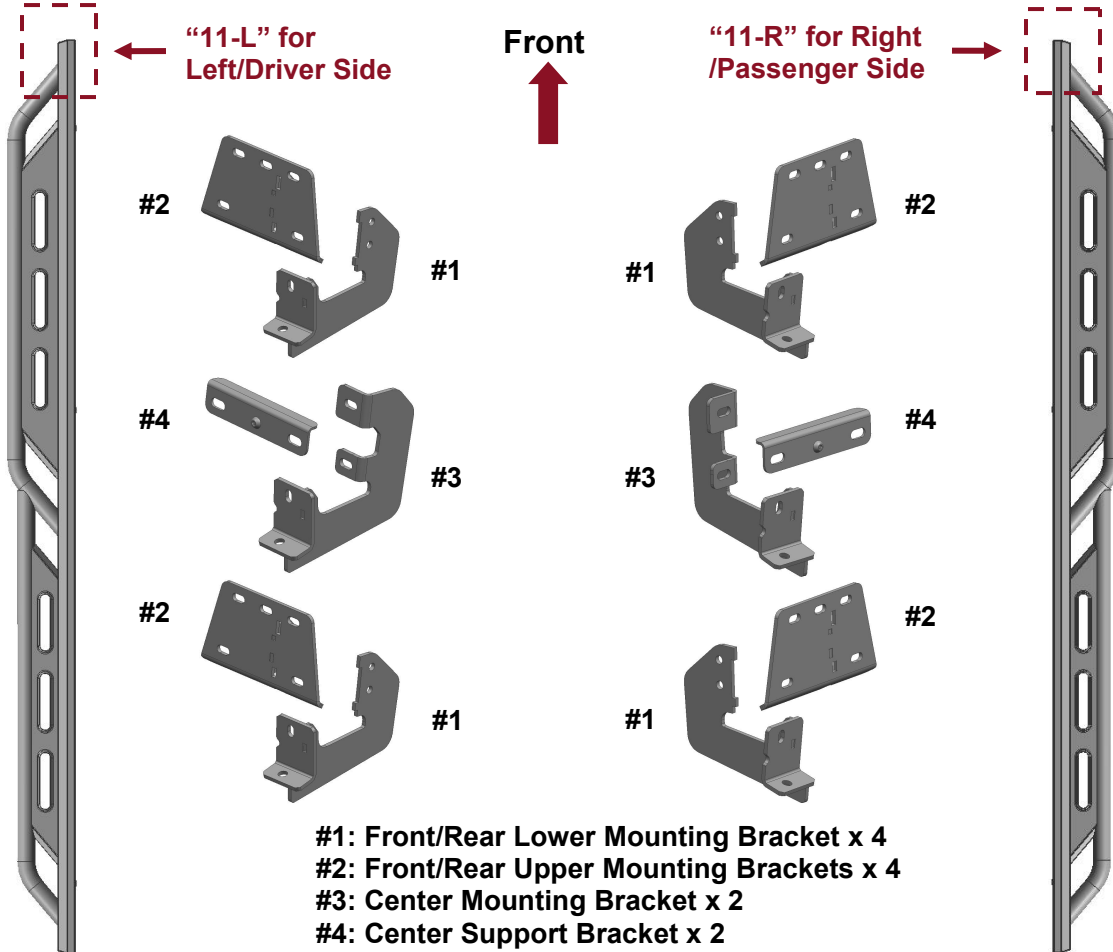

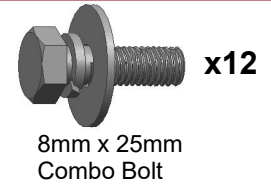
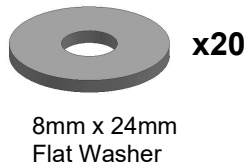
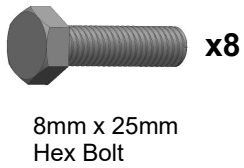

PLEASE NOTE THAT THE FOLLOWING PICTURES ARE BASED ON THE DRIVER SIDE INSTALLATION

STEP 1

Start the installation under the Driver/Left side of the vehicle. Locate the front (3) factory studs along the inner side of the body panel, **(Fig 1)**.

FIG 1

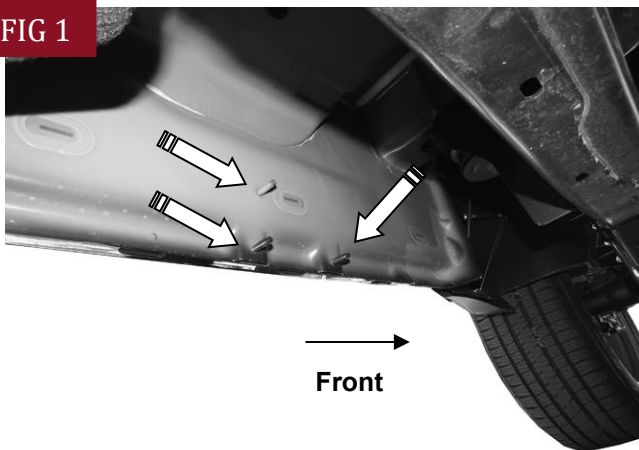

(Fig 1) Driver/Left Front mounting location

STEP 2

Select (1) Front/Rear Upper Mounting Bracket **(#2)**. Attach the Mounting Bracket to the (3) factory studs with (3) 8mm x 24mm Flat Washers and (3) 8mm Nylon Lock Nuts, **(Fig 2)**. Do not tighten hardware.

FIG 2

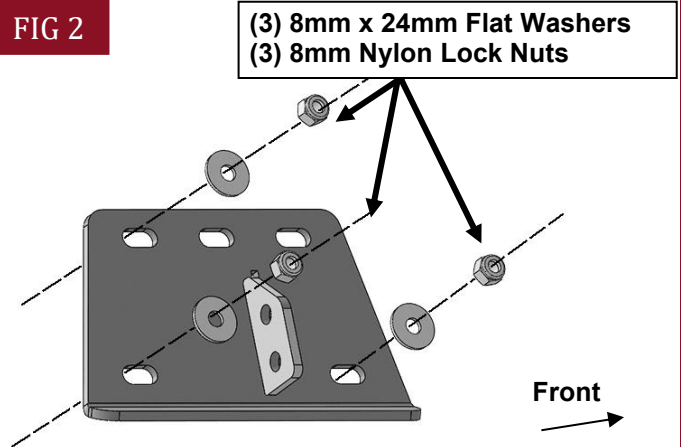

(Fig 2) Attach (1) Front Upper Mounting Bracket (#2) to the threaded studs

STEP 3

Select (1) Front/Rear Lower Mounting Bracket **(#1)**. Attach the Lower Bracket to the short side of the Upper Bracket with (2) 8mm Hex Bolts, (4) 8mm x **16mm** Flat Washers and (2) 8mm Nylon Lock Nuts, **(Fig 3)**. Do not tighten hardware.

FIG 3

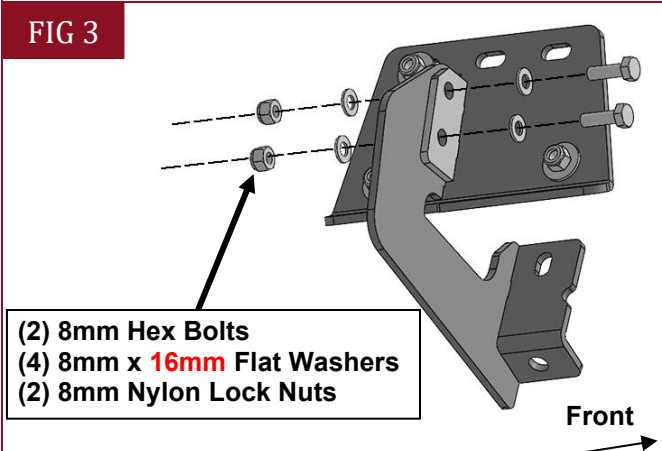

(Fig 3) Attach (1) Front Lower Mounting Bracket (#1) to the Upper Mounting Bracket (#2)

STEP 4

Move to the center location, (**Fig 4**). Select (1) Center Support Bracket (**#4**). Attach the Support Bracket to the (2) lower threaded studs with (2) 8mm x 24mm Flat Washers and (2) 8mm Nylon Lock Nuts, (**Fig 5**).

FIG 4

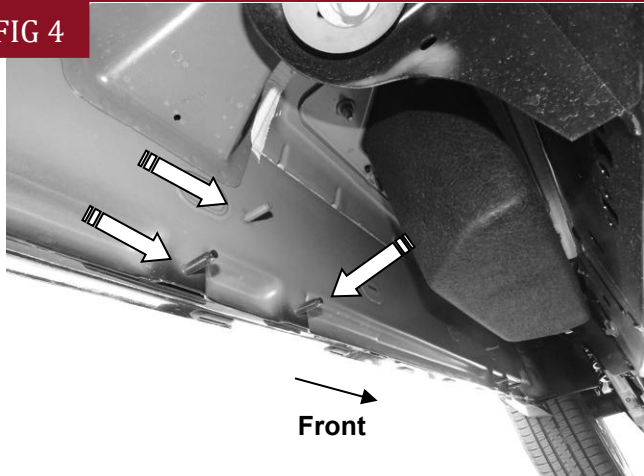

(Fig 4) Driver/Left Center mounting location

FIG 5

(2) 8mm x 24mm Flat Washers
(2) 8mm Nylon Lock Nuts

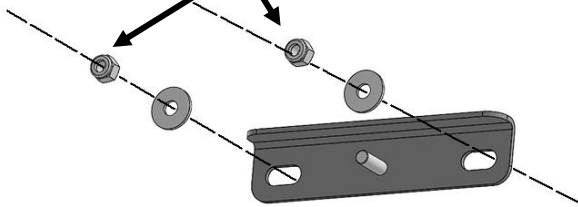

(Fig 5) Attach (1) Center Support Bracket (**#4**) to the lower (2) threaded studs on the mounting location

STEP 5

Select (1) Center Mounting Bracket (**#3**) and attach to the Support Bracket and upper threaded stud with (2) 8mm Flat Washers and (2) 8mm Nylon Lock Nuts, (**Fig 6**). Do not tighten hardware.

FIG 6

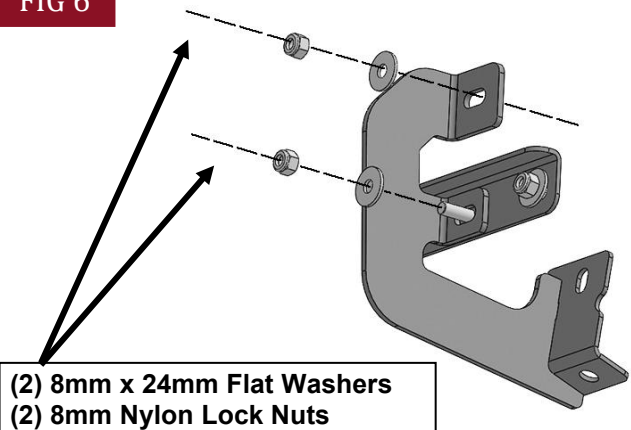

(Fig 6) Attach (1) Center Mounting Bracket (**#3**) to the upper threaded stud and Support Bracket

STEP 6

Repeat **Steps 2 & 3** to attach (1) Front/Rear Upper Mounting Bracket (**#2**) and (1) Front/Rear Lower Mounting Bracket (**#1**) to the rear mounting location, (**Fig 7**). Do not tighten hardware.

FIG 7

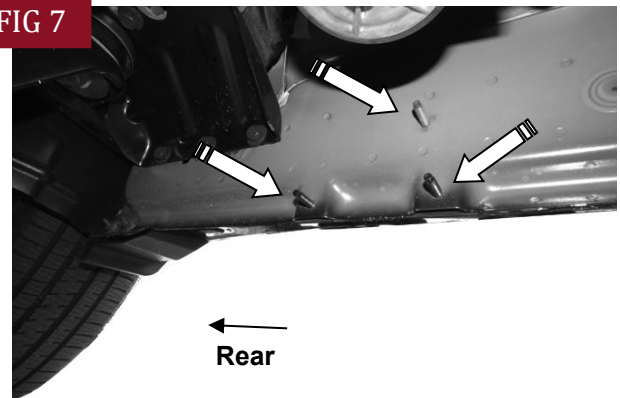

(Fig 7) Driver/Left Rear mounting location

STEP 7

Select the Driver/Left Running Board. **NOTE:** The Driver/Left Running Board will have a “11-L” on the front. **IMPORTANT:** Do not slide Running Board front to back on the Brackets or damage to the finish may result. Attach the Step to the Mounting Brackets with (6) 8mm Combo Bolts, (Fig 8). Do not tighten hardware.

FIG 8

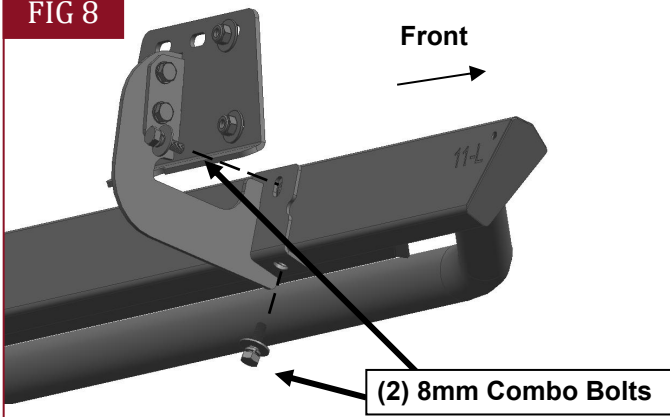

(Fig 8) Attach the Driver/Left Rocker Step to the (3) Mounting Brackets

STEP 8

Level and adjust the Running Board as necessary and fully tighten all hardware.

STEP 9

Repeat **Steps 1—8** to attach the Passenger/Right Running Board to the vehicle.

STEP 10

Do periodic inspections to the installation to make sure that all hardware is secure and tight.

Attention

To protect your investment, do not use any type of polish or wax that may contain abrasives that could damage the finish.

Mild soap may be used also to clean the Running Boards.