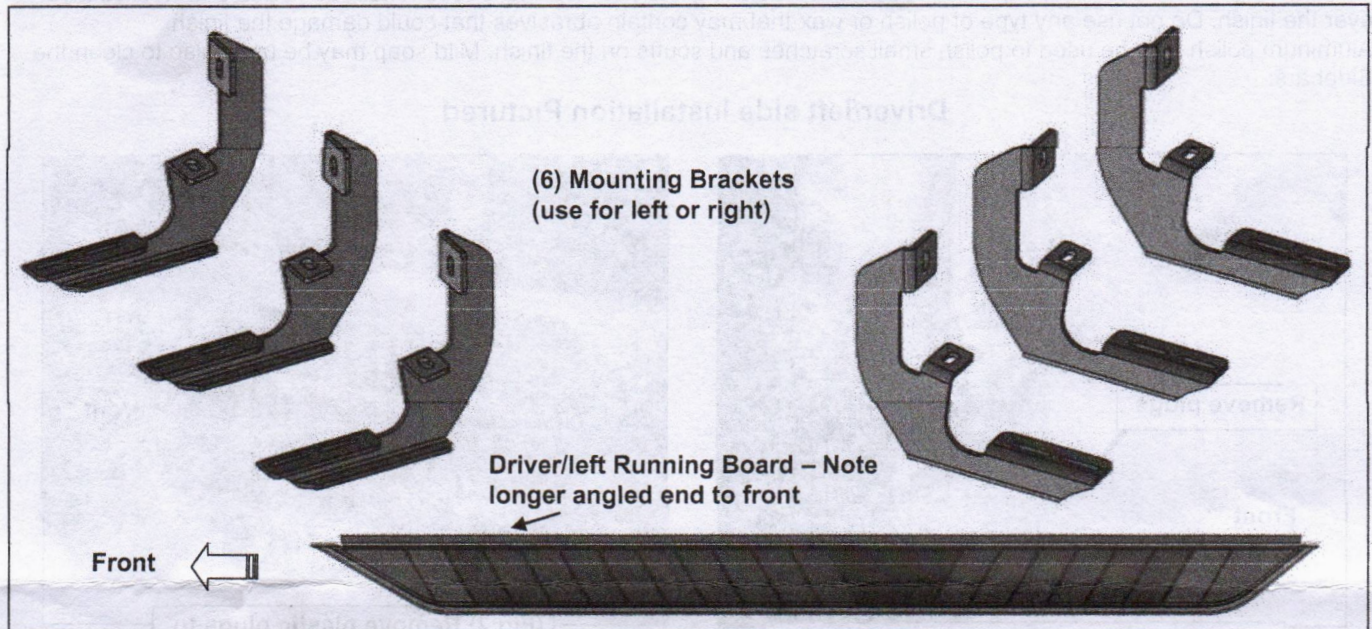

PARTS LIST: S112498

1	Driver/left Running Board	12	6mm Lock Washers
1	Passenger/right Running Board	12	6mm Hex Nuts
6	Mounting Brackets	12	8-1.25mm x 30mm Hex Bolts
12	6mm x 20mm T-Bolts	12	8mm x 24mm x 2mm Flat Washers
12	6mm x 22mm x 2mm Flat Washers	12	8mm Lock Washers

**PROCEDURE:**

REMOVE CONTENTS FROM BOX. VERIFY ALL PARTS ARE PRESENT. READ INSTRUCTIONS CAREFULLY BEFORE STARTING INSTALLATION. ASSISTANCE IS RECOMMENDED.

1. Start the installation under the driver/left side of the vehicle. Locate the plastic plugs along the bottom edge of the body, **(Figure 1)**. Mounting Brackets will attach to the 1st, 2nd and 4th threaded mounting holes. Remove the plastic plugs from each mounting location, **(Figure 2)**. Directly above each threaded insert is a top mounting location on the side of the body panel. Hold a Bracket up in place to help determine the correct mounting holes to use along the body. **NOTE:** Thread an 8mm Hex Bolt into the threaded inserts to clear paint as required.
2. Select (1) Mounting Bracket, **(Figure 3)**. Starting at the front of the driver/left side, attach the Mounting Bracket to the factory threaded holes with (2) 8mm Hex Bolts, (2) 8mm Lock Washers and (2) 8mm Flat Washers, **(Figure 3)**. Do not tighten hardware at this time.
3. Repeat **Steps 1 & 2** to attach the (2) Brackets to the center and rear mounting locations along the body panel, **(Figures 4 & 5)**.
4. Select the Driver/left Side Running Board. Use the illustration above to help determine the correct Running Board. Place the Running Board on top of the Brackets. **IMPORTANT:** Do not slide, (front to back), the Running Board on the Brackets or damage to the finish may result. Locate the channel openings in the bottom of the Running Board. Select (6) 6mm T-Bolts, **(Figure 6)**. Insert the T-Bolts into the end of the channels in the bottom of the Running Board, **(Figure 7)**. Slide the T-Bolts into position close to the location of the Brackets. Lift the Running Board up and guide the T-Bolts down through the Brackets.

PIONEER RUNNING BOARD

2019-25 1500 CHEVY SILVERADO/GMC SIERRA DOUBLE CAB
(INCLUDES DIESEL MODELS W/DEF & EXCLUDES 2019 SILVERADO 1500 LD & 2019 SIERRA 1500 LIMITED)
2020-25 SILVERADO/SIERRA 2500/3500 DOUBLE CAB (INCLUDES DIESEL MODELS W/DEF)

5. Attach the Running Board to the Brackets with (6) 6mm Flat Washers, (6) 6mm Lock Washers and (6) 6mm Hex Nuts, **(Figure 8)**.
6. Level and adjust the Running Board and fully tighten all hardware.
7. Repeat **Steps 1—6** to install the Passenger/right Side Running Board.
8. Do periodic inspections to the installation to make sure that all hardware is secure and tight.

To protect your investment, wax this product after installing. Regular waxing is recommended to add a protective layer over the finish. Do not use any type of polish or wax that may contain abrasives that could damage the finish. Aluminum polish may be used to polish small scratches and scuffs on the finish. Mild soap may be used also to clean the Sidebars.

Driver/left side Installation Pictured

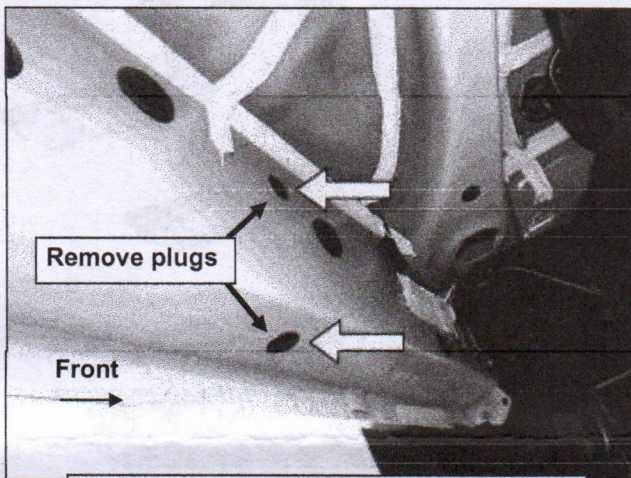

(Fig 1) Driver/left front mounting location

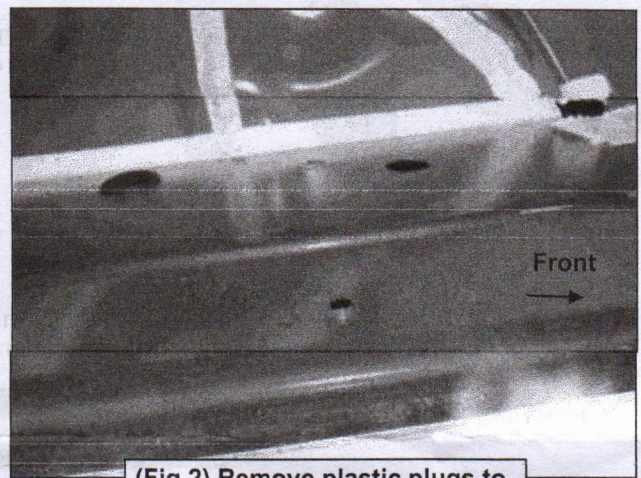

(Fig 2) Remove plastic plugs to uncover threaded inserts

- (2) 8mm Hex Bolts
- (2) 8mm Lock Washers
- (2) 8mm Flat Washers

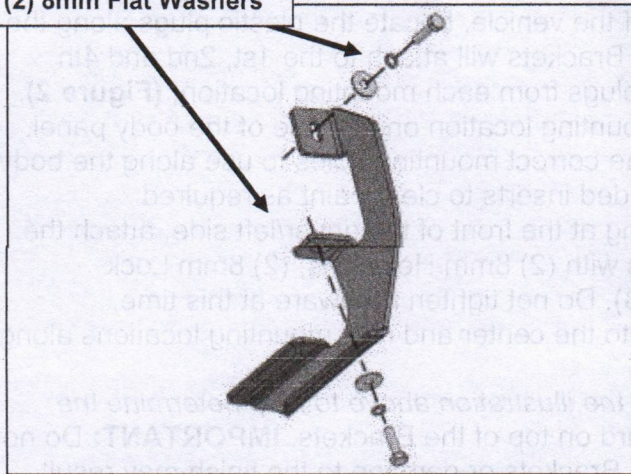

(Fig 3) Mounting Bracket illustration

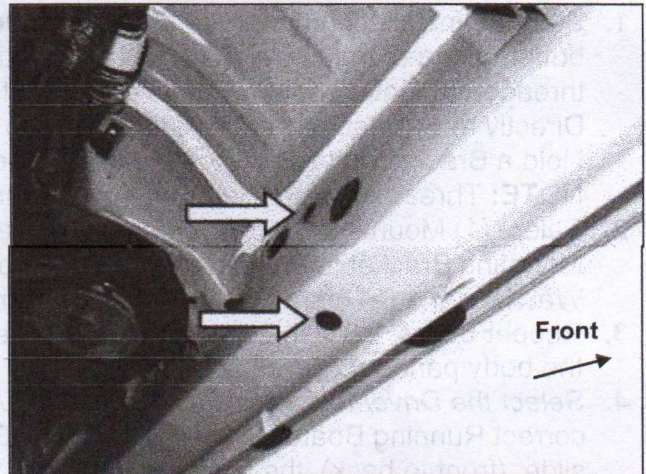

(Fig 4) Driver side 2nd mounting location

PIONEER RUNNING BOARD
2019-25 1500 CHEVY SILVERADO/GMC SIERRA 1500 DOUBLE CAB
(INCLUDES DIESEL MODELS W/DEF & EXCLUDES 2019 SILVERADO 1500 LD & 2019 SIERRA 1500 LIMITED)
2020-25 SILVERADO/SIERRA 2500/3500 DOUBLE CAB (INCLUDES DIESEL MODELS W/DEF)

Driver/left side Installation Pictured

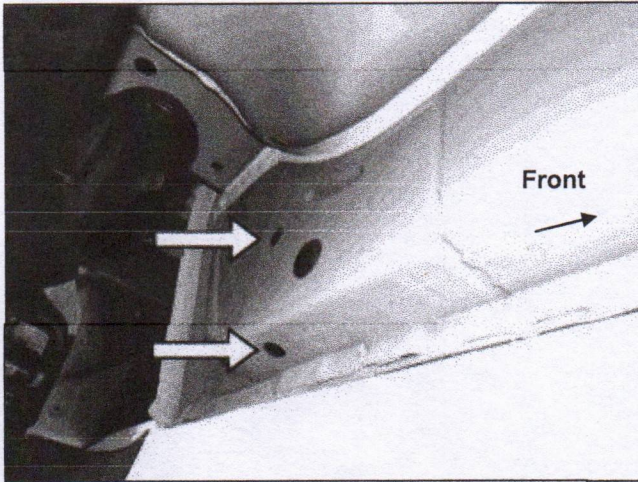

(Fig 5) Driver side rear mounting location

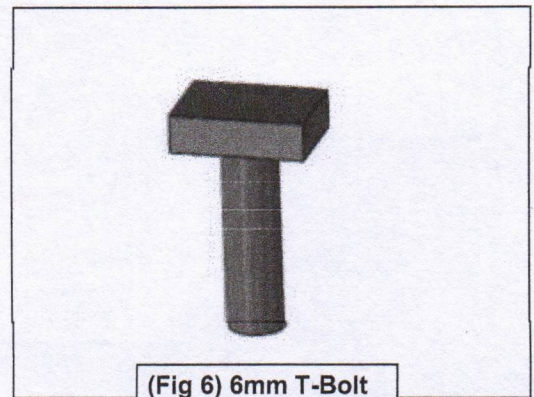

(Fig 6) 6mm T-Bolt

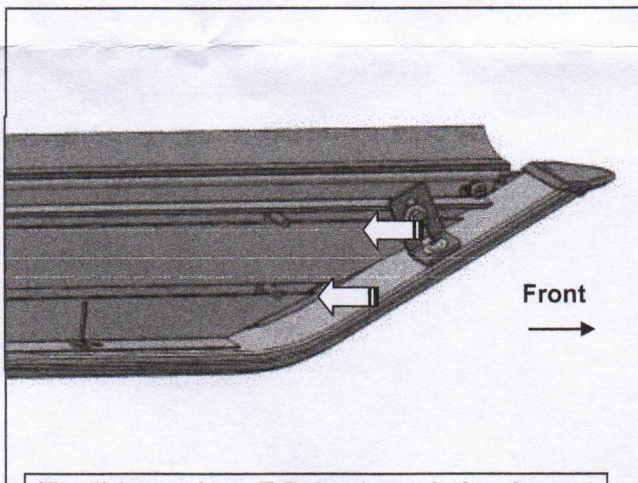

(Fig 7) Insert 6mm T-Bolts through the channel openings in the bottom of the Running Board

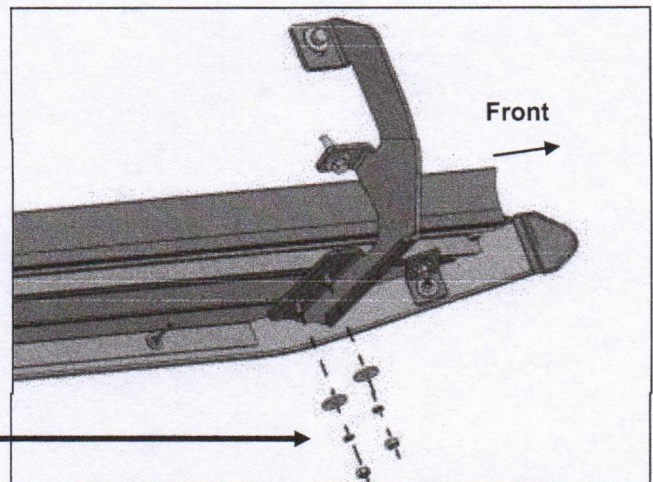

(Fig 8) Attach Running Board to Brackets

- (2) 6mm Flat Washers
- (2) 6mm Lock Washers
- (2) 6mm Hex Nuts