

INSTALLATION INSTRUCTIONS : TRACE RACK TR9002 2019-CURRENT GMC/CHEVY 5-1/2', 6-1/2' Box and 8' , MAX BED COVER WIDTH 70.5"

READ THIS NOW!

Your truck should look like the one shown. If you think you are missing any parts, think that this part number is not for your truck or have any installation question, call our customer service department at toll free:

888-588-6101 or locally 800-265-8137.

Other ways to reach RealTruck

Backrack:

email: info@backrack.ca

Support@backrack.com



IMPORTANT!

The **RealTruck Backrack - TRACE RACK** is secured to your truck with a pair of "Stake Pocket Bolts" specifically designed for your make and model of truck. These bolts mount into each of the two front stake pockets. The **TRACE RACK** assembly sits on the bed rails of your truck and is secured to these Stake Pocket Bolts. If your truck has a **BEDLINER** we suggest you remove it to install the Stake Pocket Bolt.

**ASSEMBLY SHOWN WITH
OPTIONAL SAFETY MESH**

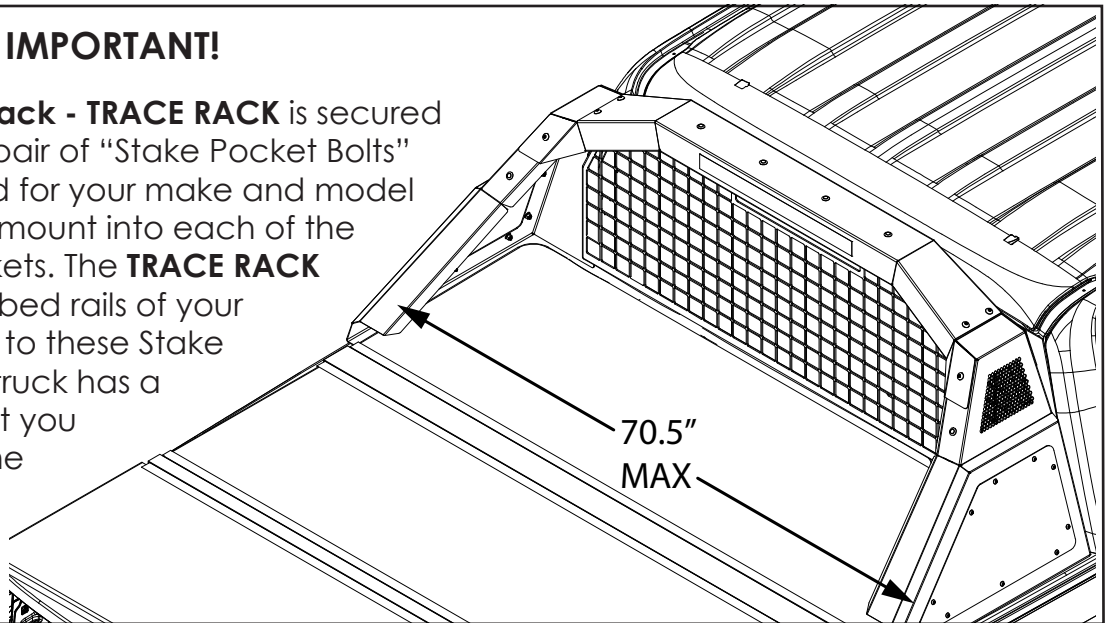

READ THIS BEFORE INSTALLATION !

RealTruck Backrack Inc is not affiliated with any Tonneau manufacturers products that are used in conjunction with RealTruck Backrack products. RealTruck Backrack Inc assumes no responsibility for any warranty offered by the Tonneau manufacturer and is not responsible in any way for any warranty claims or damages that may be made in relation to the Tonneau Cover. The Tonneau Cover manufacturer will have supplied a strap or fastening device designed to secure the cover in place when the cover is in an open position. Failure to secure the cover can result in personal injury or damage. RealTruck Backrack Inc has supplied a strap that is enclosed in this package. In the event that the strap or fastening device clip that was supplied with your Tonneau Cover is impeded or, in any way insufficient in its ability to secure the Tonneau in an open position after the installation of our RealTruck Backrack products, it is solely your responsibility to attach the strap that is supplied in this pack-age for the purpose of securing the Tonneau Cover in an open position. The enclosed strap provides sufficient length to loop around the Trace Rack top cross bar frame and latch the Tonneau Cover securely and safely. You may be required to remove the Tonneau manufacturers supplied strap and replace it with the supplied longer strap. It is solely your responsibility to ensure that the strap is secured sufficiently and safely. RealTruck Backrack Inc is not responsible for any harm, damage, injury or claim that may result from this installation. By installing this product on your truck you assume complete responsibility for it's safe installation and forfeit RealTruck Backrack Inc from any liability claim or damages.

FOR MORE INFORMATION SCAN HERE!



1a

****FOR 5-1/2 ft BOX ONLY****

Using a rotary tool or sharp knife, carefully cut driver and passenger rail cap to expose stake pocket

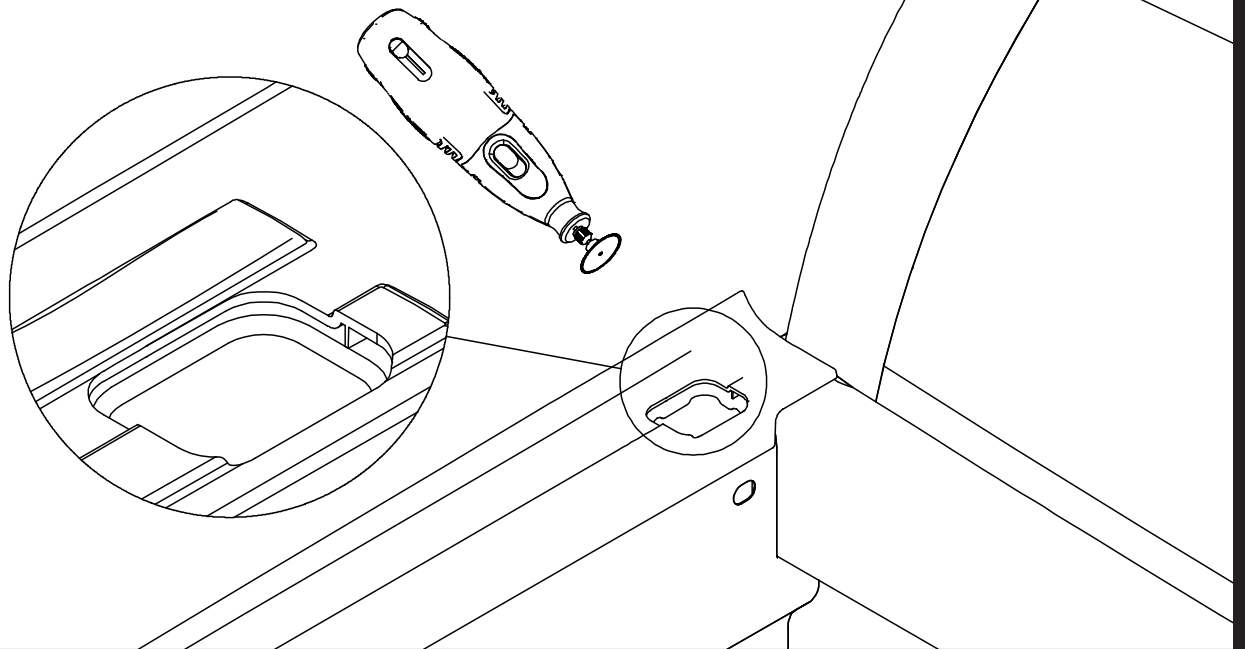

1b

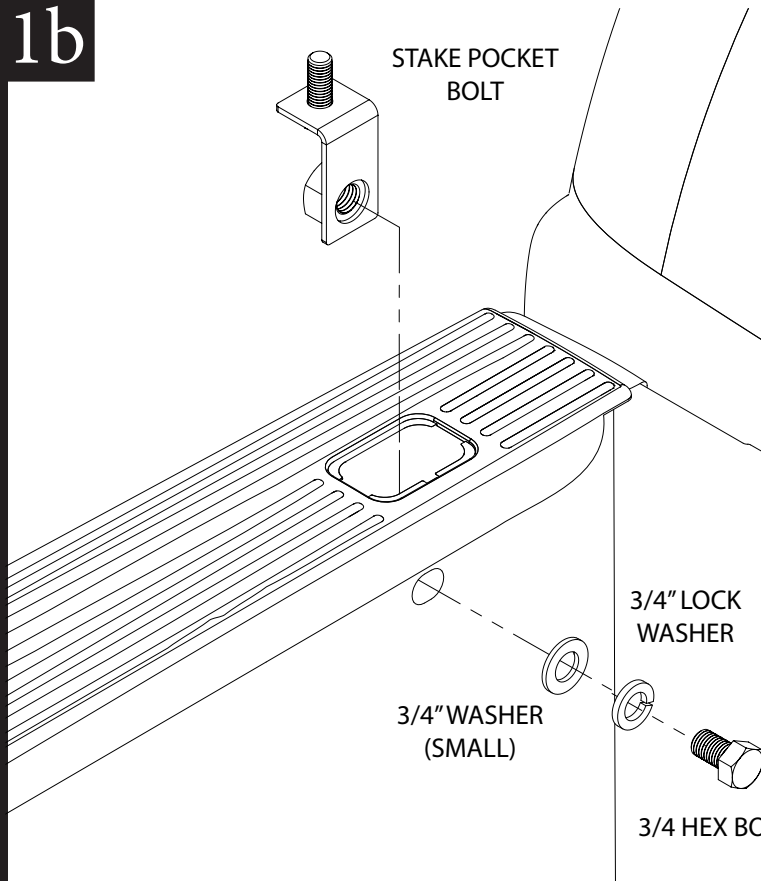

- Carefully insert #31 into stake pocket, and into hole on the inside of truck bed.
- Place washer #30, lock washer #29 and bolt #33 as shown.
- Snug bolt, do not fully torque at this stage.

2

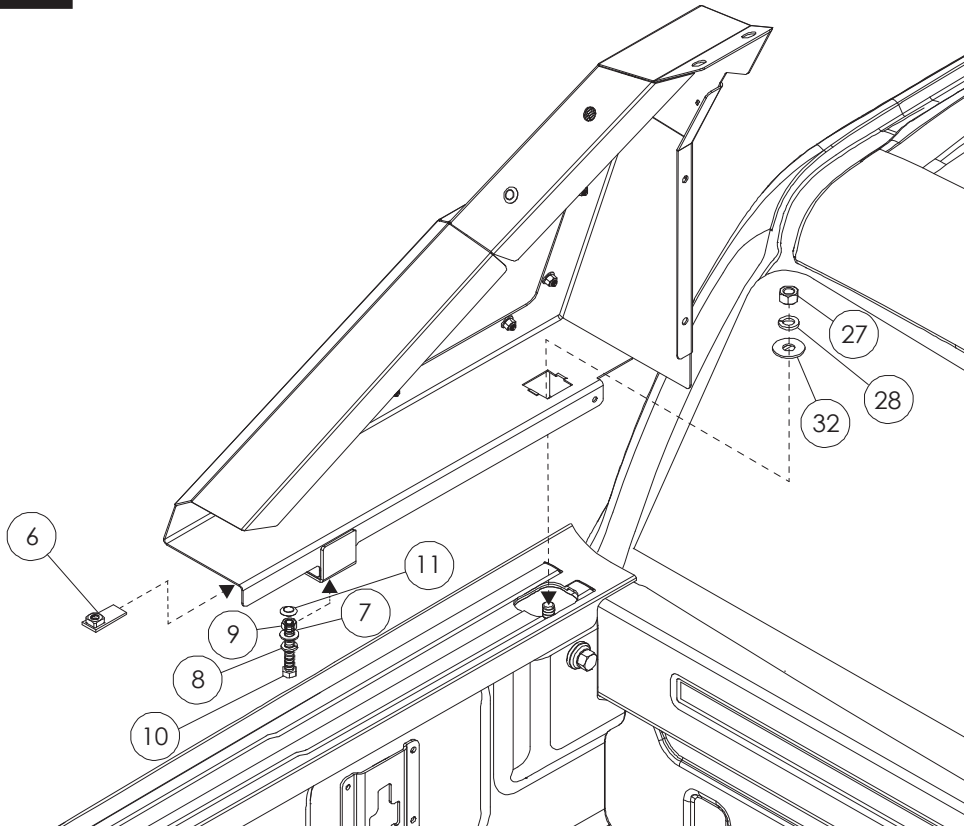

- Install Trace Rack side wing assembly as shown in diagram
- Place weld nut assembly #6 into position under bed
- Loosely thread in rear bolt #10 with washers #8 and #7 and jam nut #9.
- Place washer #32, lock washer #28, and thread nut #27 into stake pocket hole.
- Position bracket forward and against inside rail.
- Semi tighten nut #27 and bolt #10.

3

- Install Top cross bar onto Trace Rack side wing assemblies.
- Starting from the top, install bolts washers and nuts
- gradually tighten bolts being careful to keep Trace Rack in position.
- Once the top bolts are tightened, If you purchased the optional Safety Mesh insert, follow instructions to install it now before final torque of the front stake pocket bolt assemblies and the rear pinch bolt assemblies
- If you purchase the Safety Mesh insert at a later time, loosen the front stake pocket bolts and rear pinch bolts, follow the Safety Mesh installation instructions and re torque all fasteners.

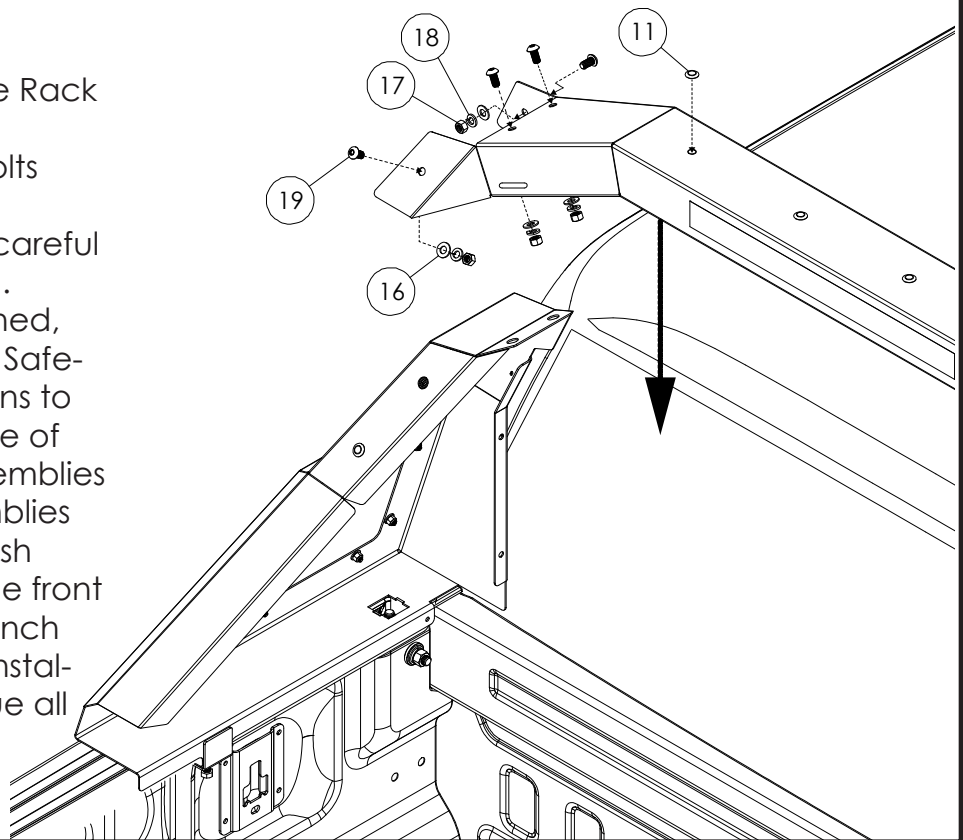

4

- Place Trim Panel #4 (Blank Trim Panel shown - See dealer for trim panel design options)
- Install bolt #12, Flat washer #16, Lock Washer #18 and Nut #17.
- Torque bolts evenly by gradually tightening in a criss cross fashion
- Install optional rubber bumper #23 if you are using a tonneau cover
- Finish by installing hole trim plugs into any unused 3/8" holes.
- Trim plugs can be removed or omitted when using bolt on accessories

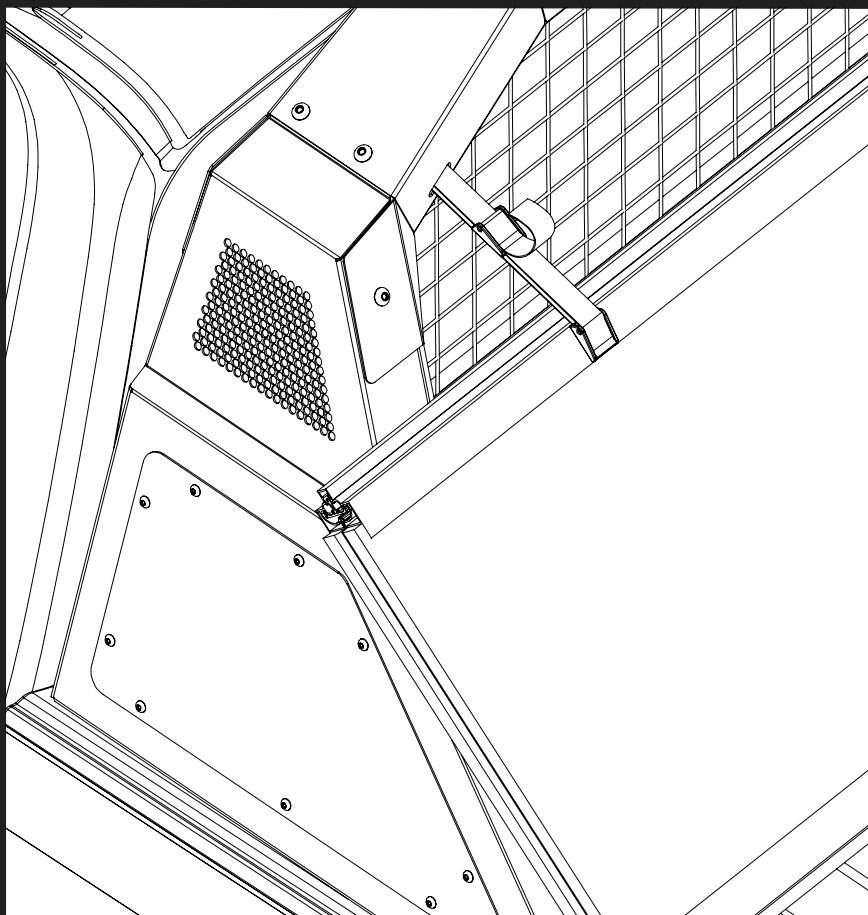
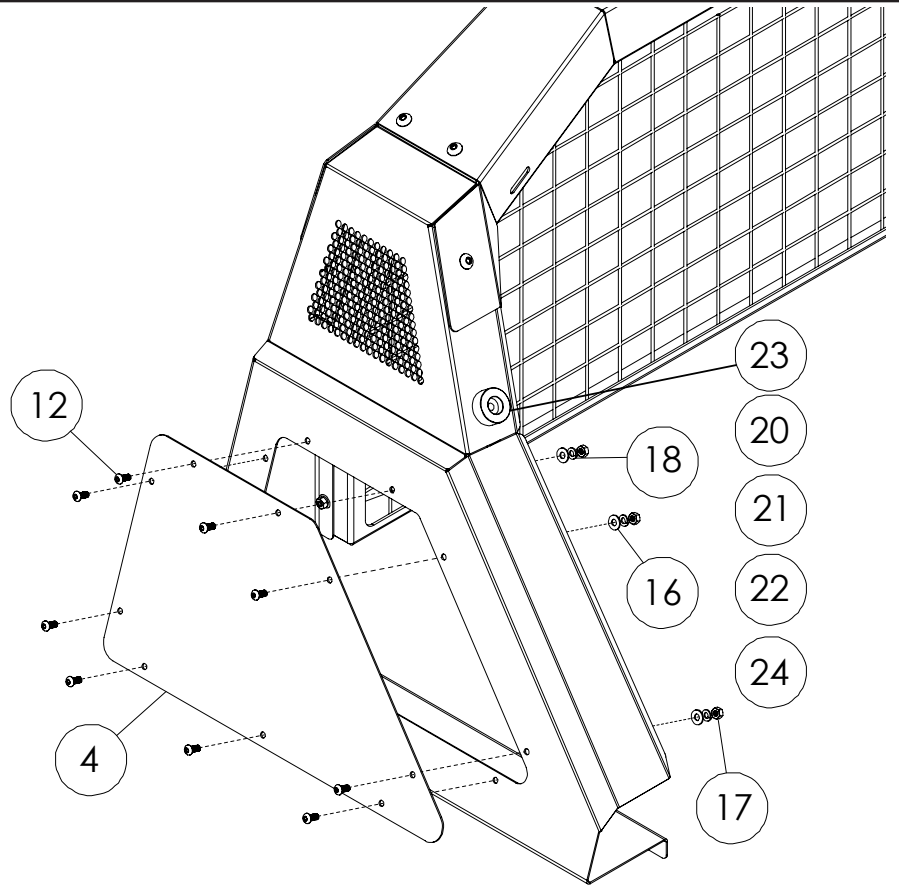

****Use supplied strap only when the original bed cover manufacturer strap will not work**
Cover must be secured in the open position in order to prevent wind damage to vehicle and or cover. Use of this alternate strap may void the warranty from the cover manufacturer. Check with cover supplier for further information**

- Loop strap through slot on Cross Bar as shown
- Snug strap using strap slide.
- Feed strap through existing strap loop on your bed cover.
- Feed Strap through quick tight buckle and tighten.