



6-INCH RUNNING BOARDS

2007-2018 SILVERADO 1500 CREW CAB

2007-2019 SILVERADO 2500-3500 CREW CAB

2007-2018 SIERRA 1500 CREW CAB

2007-2019 SIERRA 2500-3500 CREW CAB

INSTALLATION INSTRUCTIONS

CONTENTS

- (1) LH Running Board
- (1) RH Running Board
- (4) LH Step Brackets
- (3) RH Step Brackets
- (1) RH Front Brackets
- (1) RH Front Reinforcement Brackets
- (16) M8 x 30mm Hex Bolts
- (17) M8 x 24mm OD x 2mm Flat Washers
- (17) M8 Lock Washers
- (15) M8 Clip Nuts
- (16) M8 x 25mm Combo Bolts
- (1) M8 Bolt Plate
- (1) M8 x 40mm Hex Bolt
- (1) M8 x 28mm OD x 3mm Flat Washer
- (1) M8 Nylon Lock Nut

TOOLS REQUIRED

- 13mm
- Sockets/Wrenches
- Ratchet

SKU # S171694

Edited:12/12/2023

STEP 1

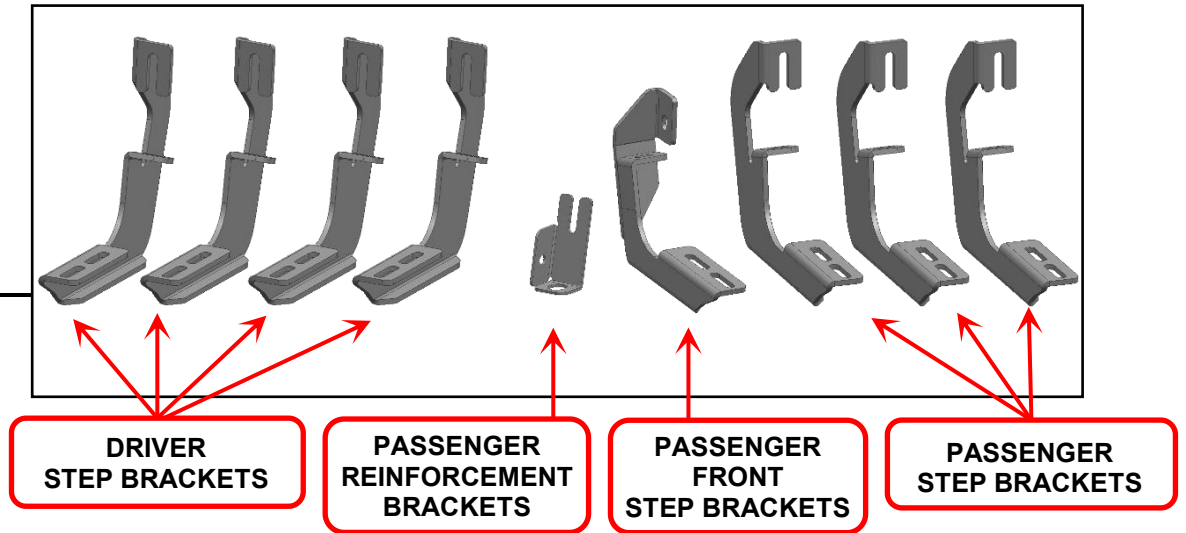

Mounting Brackets are the same. Please identify each mounting bracket using the engraved location identifier. **Notice: The Passenger/Right Front Mounting location will use front step bracket and reinforcement bracket.**

DF: Driver Front
DC: Driver Center
DC: Driver Center
DR: Driver Rear

PF: Passenger Front
PC: Passenger Center
PC: Passenger Center
PR: Passenger Rear

STEP 2

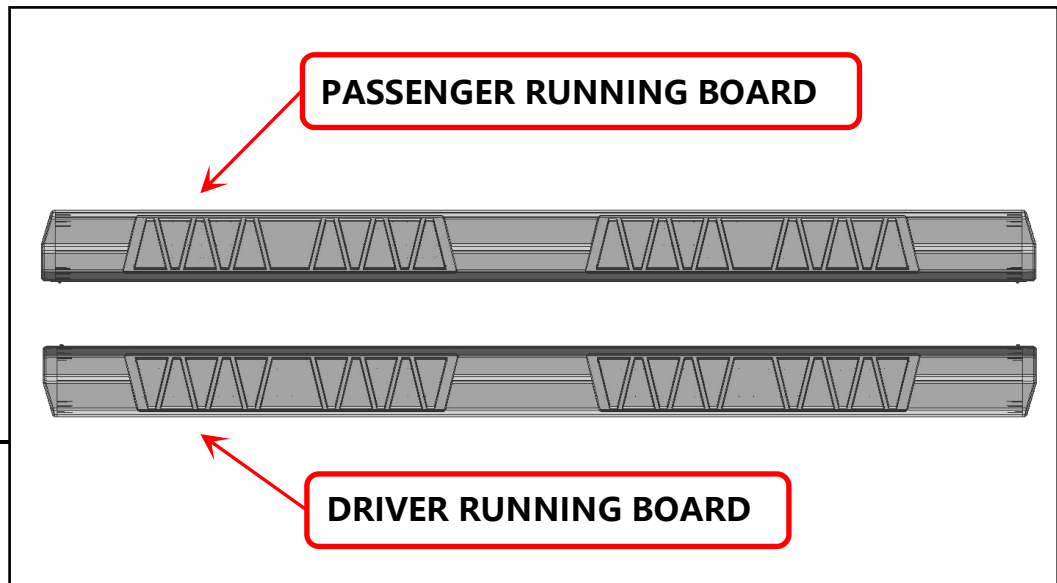

Identify each side step by the front of the Running Board. **Notice: "D" for Driver/Left Side; "P" for Passenger/Right Side.**

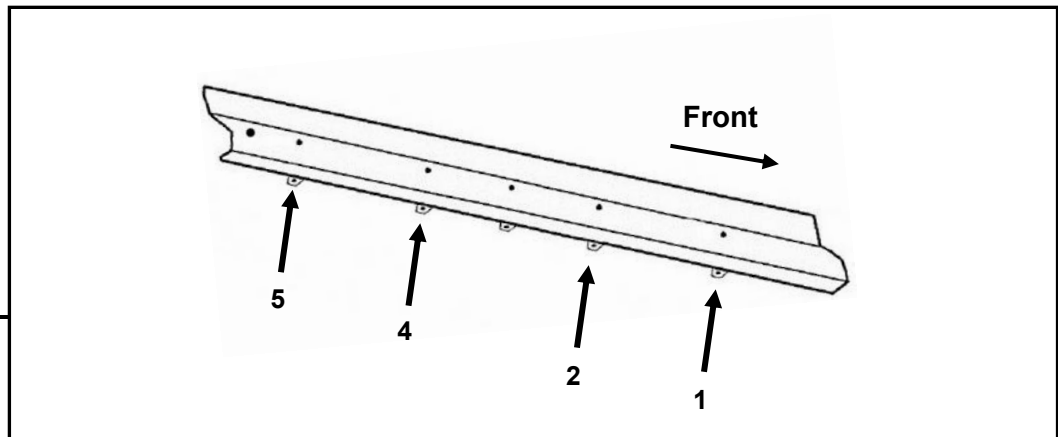

STEP 3

Start installation toward the front of the Driver/Left side of the vehicle.

Locate the 5 tabs along the bottom edge of the body. Mounting Brackets will bolt to the 1st, 2nd, 4th, and 5th mounting tabs. Directly above each tab is a top mounting location on the side of the rocker panel.

Determine if the vehicle has a factory installed threaded insert or not in body panel.

Vehicles **with** factory threaded inserts in body panel follow **Step 4.1**:

Vehicles **without** factory threaded inserts in body panel follow **Step 4.2**:

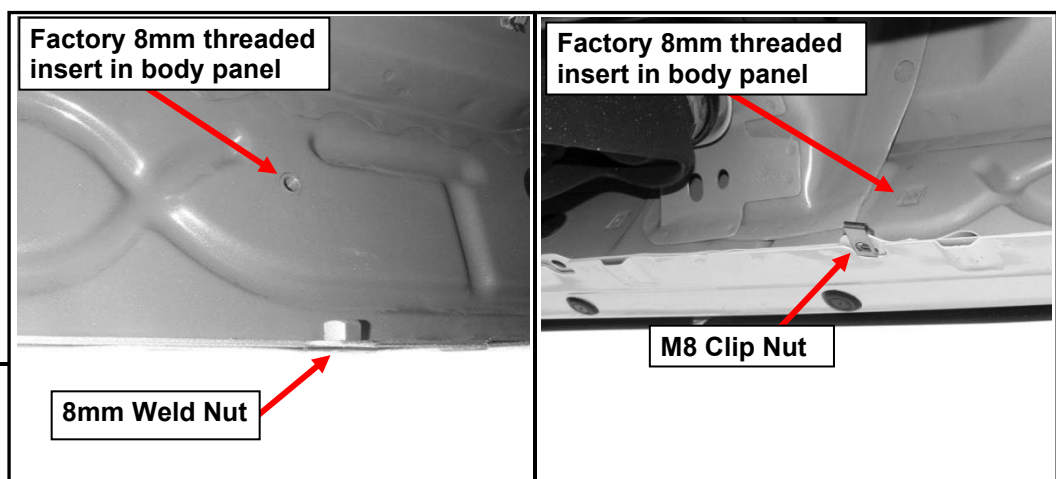

STEP 4.1

Determine the correct procedure for your model year and each Bracket location.

a. Flat tab on pinch weld with factory installed weld nut:

Thread hex bolt into weld nut from the backside-down to clear paint from threads

b. Flat tab on pinch weld with hole:

Slide the (1) M8 clip nut over the tab with the nut facing up behind the tab. Line up threaded nut with hole in the tab.

STEP 4.2

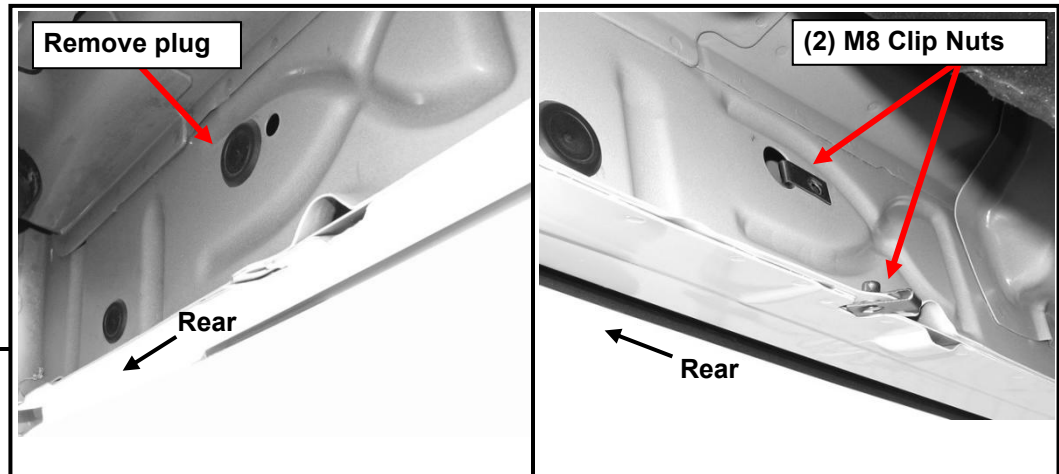

Remove the rubber plug from the larger hole. Slide (1) M8 clip nut into the larger hole. Line up the threaded nut with the smaller hole.

Determine if the vehicle has a factory installed weld nut or a hole on the edge of the pinch weld.

Flat tab on pinch weld with factory installed weld nut follow Step 5.1:

Flat tab on pinch weld with hole follow Step 5.2:

STEP 5.1

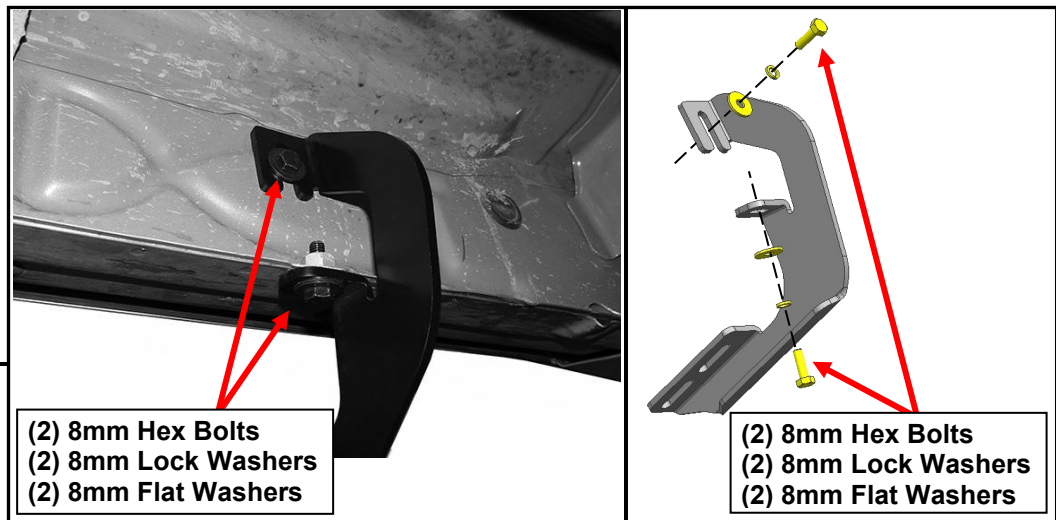

Loosely fit the (1) Driver Front step bracket to the vehicle installed weld nut using (2) M8 x 30mm bolts, (2) M8 lock washers, and (2) M8 flat washers. Do not fully tighten to allow for later adjustments.

STEP 5.2

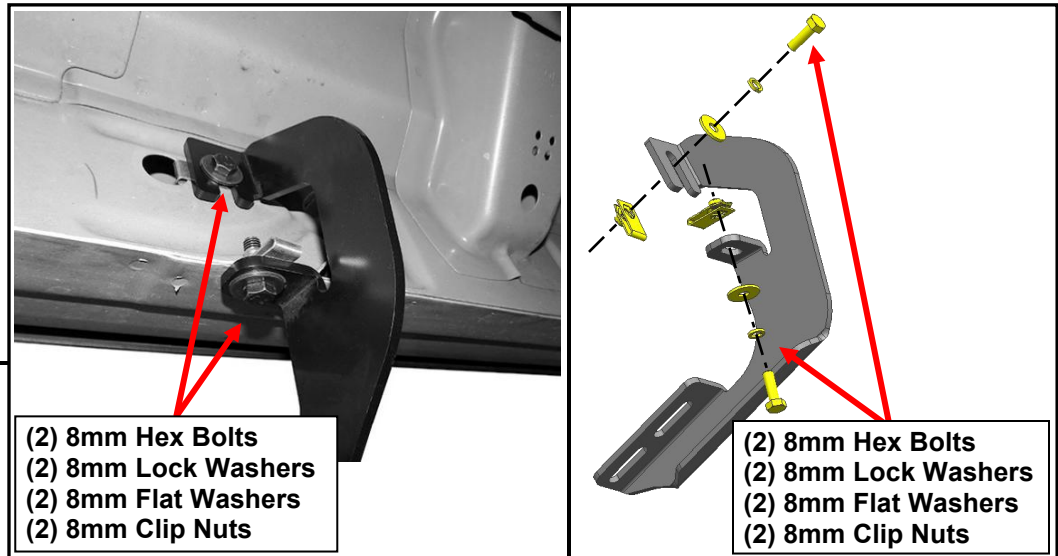

Loosely fit the (1) Driver Front step bracket to the vehicle threaded body hole using (2) M8 x 30mm bolts, (2) M8 lock washers, (2) M8 flat washers, and (2) M8 clip nuts. Do not fully tighten to allow for later adjustments.

STEP 6

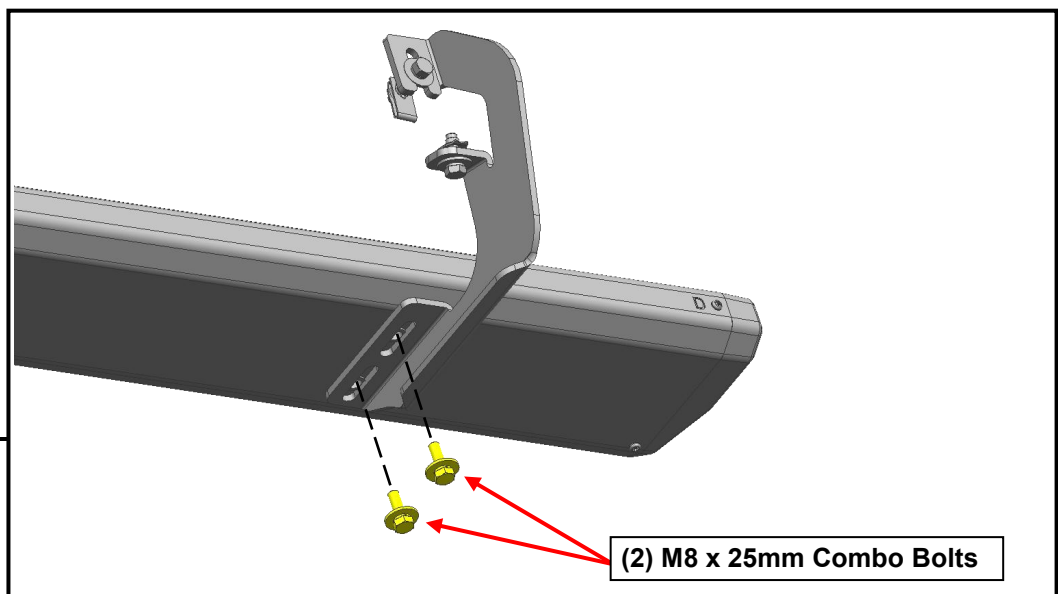

With all brackets loosely mounted to the vehicle, fit the (1) LH Running Board onto the brackets, and loosely secure into place using (8) M8 x 25mm combo bolts.

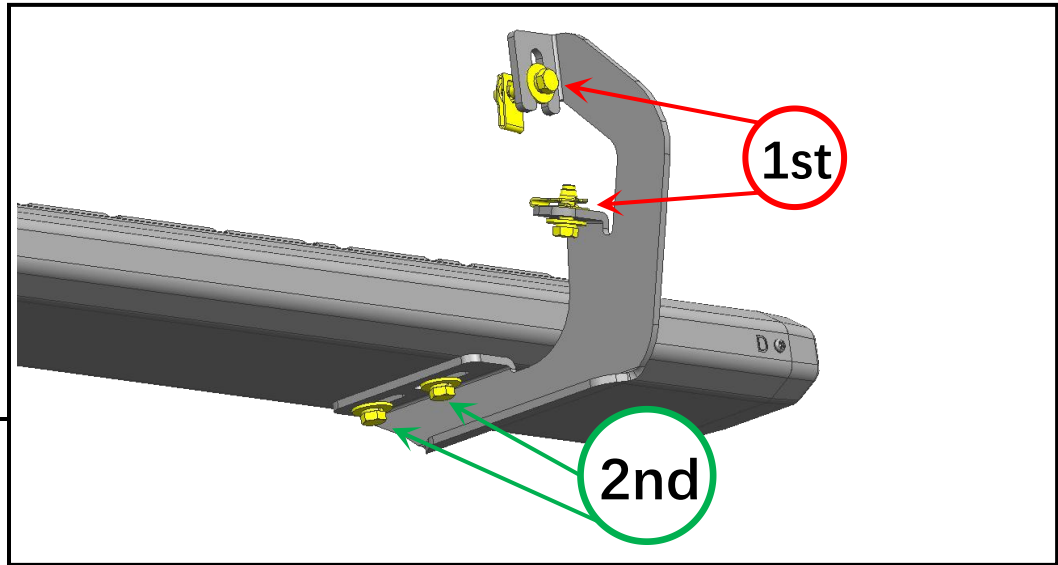

STEP 7

Tighten the mounting brackets to the vehicle. Adjust the Running Board to the desired angle, and tighten the M8 combo bolts to secure the step into place. See photo for tightening order visual.

Move to the Passenger/Right side of the vehicle.

Determine if the vehicle is equipped with a plastic diesel exhaust fluid (DEF) tank or not.

Vehicles **without** DEF tank, skip to **Step 9**:

Vehicles **with** DEF tank, and on 2017 and beyond follow **Step 8.1**:

Vehicles **with** DEF tank, and up to 2016 follow **Step 8.2**:

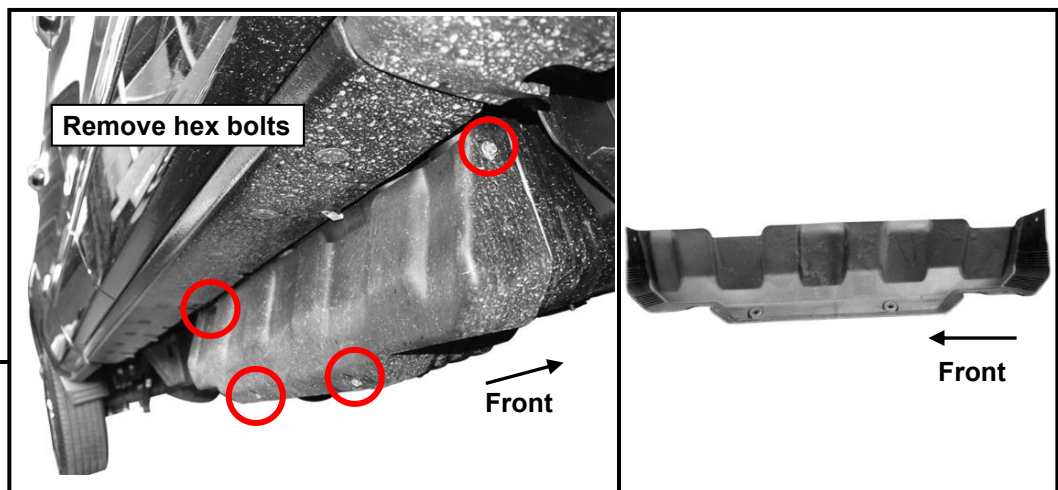

STEP 8.1

Remove the (4) hex bolts attaching plastic cover to DEF tank and remove plastic cover for better access. **NOTE:** On 2017-on 2500/3500 models, only remove plastic cover from DEF tank. **Do not lower DEF tank** and proceed to **Step 9**.

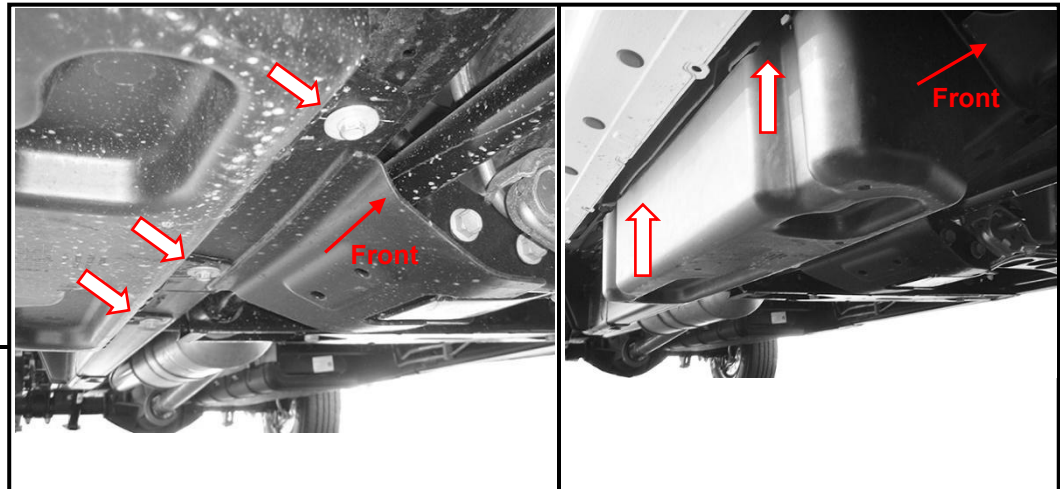

STEP 8.2

- Remove the inside (3) hex bolts the tray to the frame, and remove the tray.
- Release the tank filler hose. Release the plug for the sending unit on the top of the tank.
- Support the tank with a floor jack. Place a smooth flat surface, (wooden block for example), between the floor jack and the tank to avoid damaging the plastic tank. Do not push up on the tank, only support the weight of the tank with the jack.
- Remove the outside (2) bolts securing the tank straps to the vehicle. Tilt the straps to release from the brackets. Slowly lower the tank until the top of the tank is almost visible. Use blocks or stands to support the tank while installing the Front Upper and Lower Brackets.

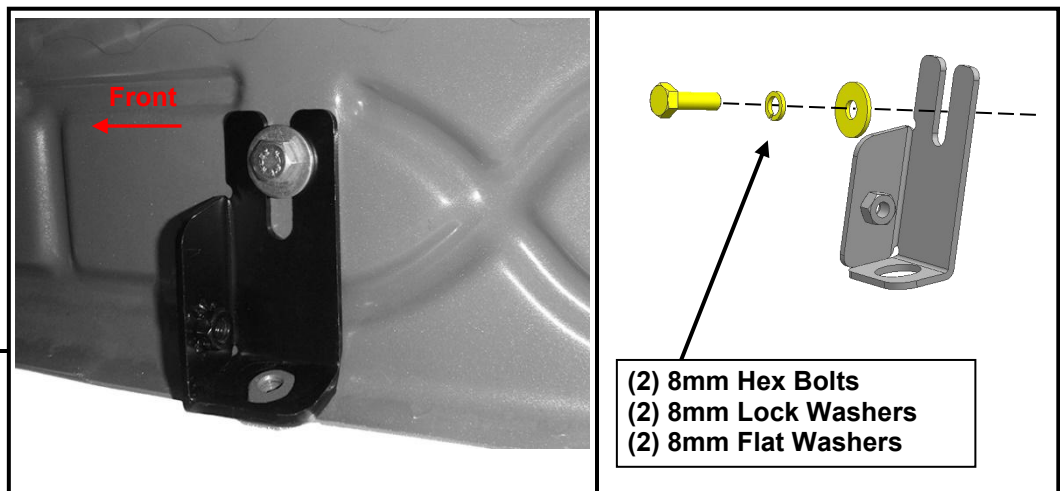

STEP 9

Locate the first tab on the edge of the pinch weld. Repeat **Steps 4 & 5** to attach the (1) Passenger Front reinforcement bracket to the side of the rocker panel. Do not fully tighten to allow for later adjustments.

Determine if the vehicle has a weld nut or a hole on the edge of the pinch weld.

Vehicles with a weld-nut follow **Step 10.1**:

Vehicles with flat tab and hole follow **Step 10.2**:

STEP 10.1

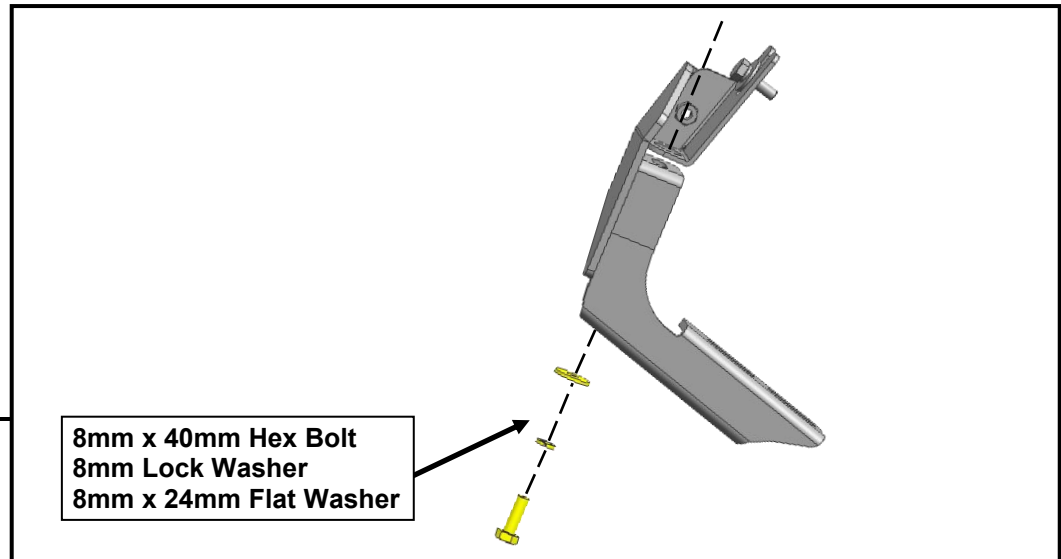

Slide the Bracket over the weld-nut. Loosely connect the (1) Passenger Front step bracket to the bottom of the body and weld-nut using (1) M8 x 40mm hex bolt, (1) M8 x 24mm flat washer, and (1) M8 lock washer.

STEP 10.2

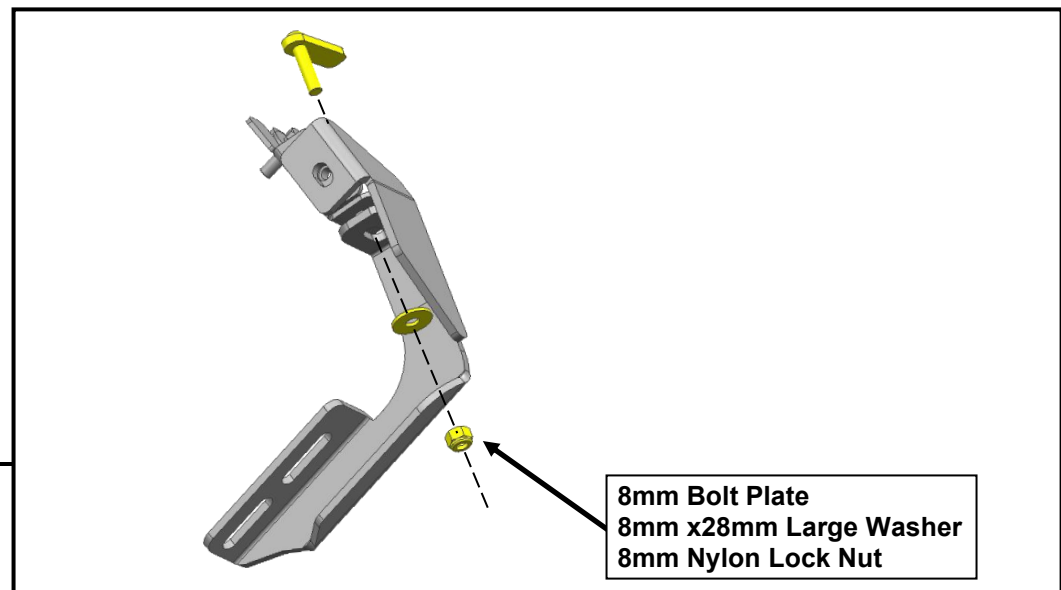

Insert (1) M8 bolt plate down through the hole in the Passenger reinforcement bracket and tab. Loosely connect the (1) Passenger Front step bracket to the bottom of the body and (1) M8 bolt plate using (1) M8 x 28mm flat washer, and (1) M8 Nylon Lock Nut.

STEP 11

8mm x 30mm Hex Bolt
8mm Lock Washer
8mm x 24mm Flat Washer

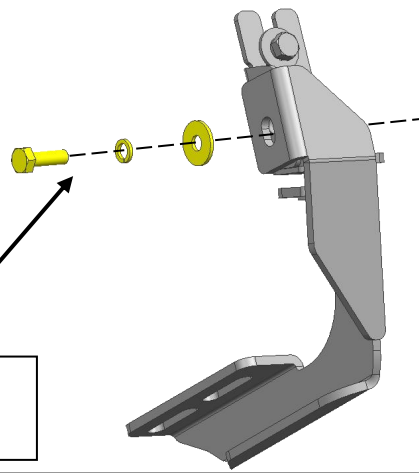

Loosely connect the (1) Passenger Front step bracket to the (1) Passenger reinforcement bracket using (1) M8 x 30mm hex bolt, (1) M8 x 24mm flat washer, and (1) M8 lock washer.

For 2017-on 2500/3500 DEF tank models:

STEP 12

mark pictured is
approximately 70mm x 10mm

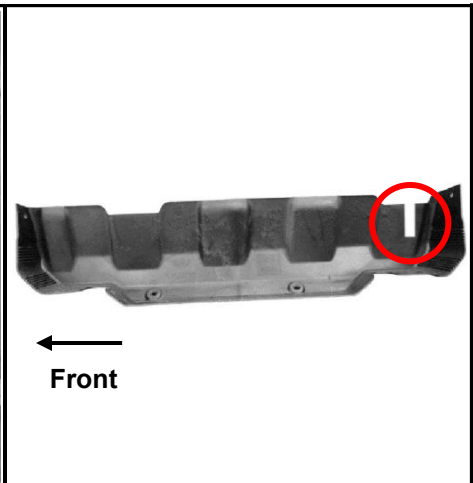
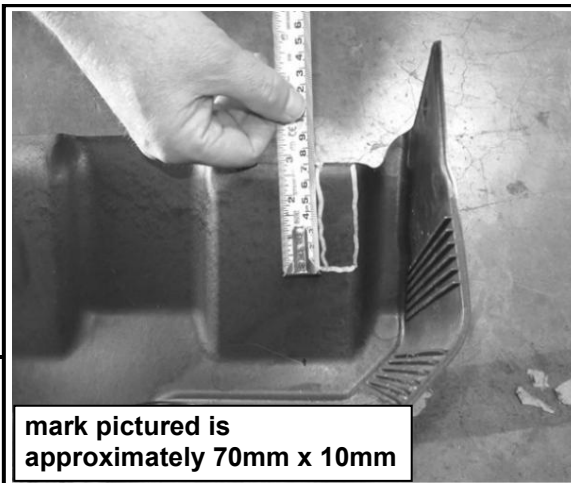

Locate the 2nd mounting location along the bottom edge of the body. Hold the DEF cover in place and mark the 2nd Bracket location onto the cover. Use a sharp knife or hacksaw blade to carefully cut a slot in the plastic cover to clear the 2nd Bracket. Remove as little plastic as possible

Repeat steps 4-7 for the remaining Passenger step brackets and RH Running Board.

Once the Sidebar has been attached and all hardware fully tightened, reinstall the DEF tank and cover, if equipped, as described in **Step 8**.

Installation is now complete.