

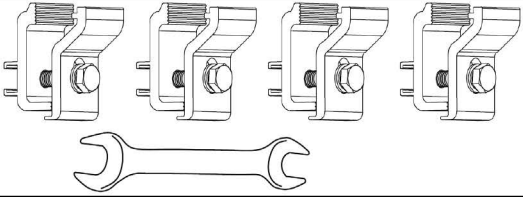



Low Profile Hard Tri-Fold Tonneau Cover Installation Instructions

When you open the tonneau cover box you will see the accessories:

Item	Description	Qty	Picture
1-A	Tonneau Cover	1	
1-B	Left Side Rail	1	
1-C	Right Side Rail	1	
1-D	Front Bolt	2	
1-E	Drain Tube	2	
1-F	Front Support Plate (Including Bolts)	2	
1-G	Side Rail Locking Tongue (including Bolts)	2	

1-H	Clamp Assembly (Clamps A) #17 Wrench	4	
1-I	Rubber Strip	1	
1-J	Sponge pad	1	

Accessories: Foam seal tape 1pc, Allen Wrench 1pc and Rubber strip 1 pc

STEPS:

1. Check Contents of carton with the list above.
2. Insert the drain tubes(1-E) into the front of side rails.

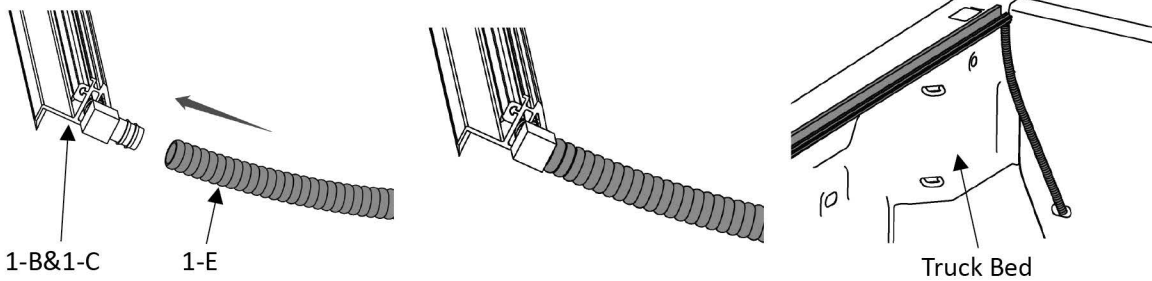

3. 3-1 Slide the Front Support Plate (1-F) into the side rails, and move the Front Support Plate (1-F) to front of side rail.

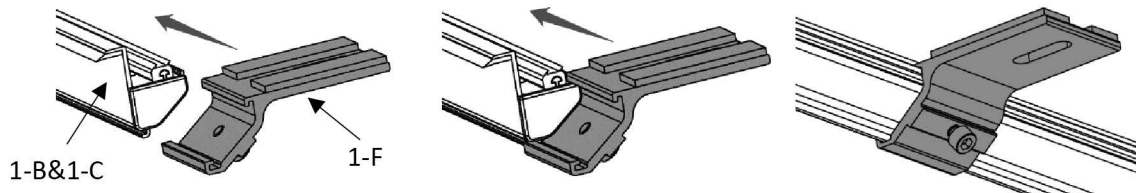

3. 3-2 Slide the Side Rail Locking Tongue (1-G) into side rail and move it to the rear of side rail. Do not tighten the bolts.

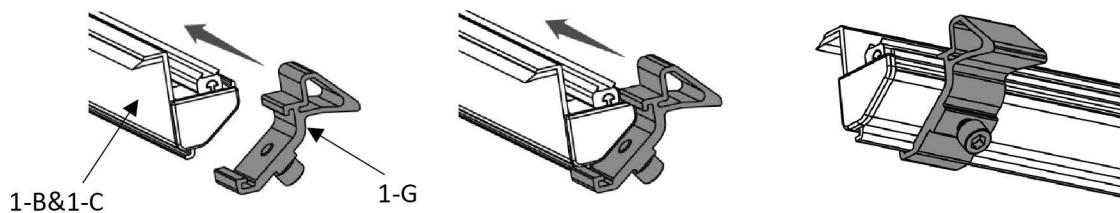

4. Cut the Rubber strip into six (or more) pieces. Some truck bed edges are not flat, so you need to stick the rubber strips on the side rail's upper or lower edges.

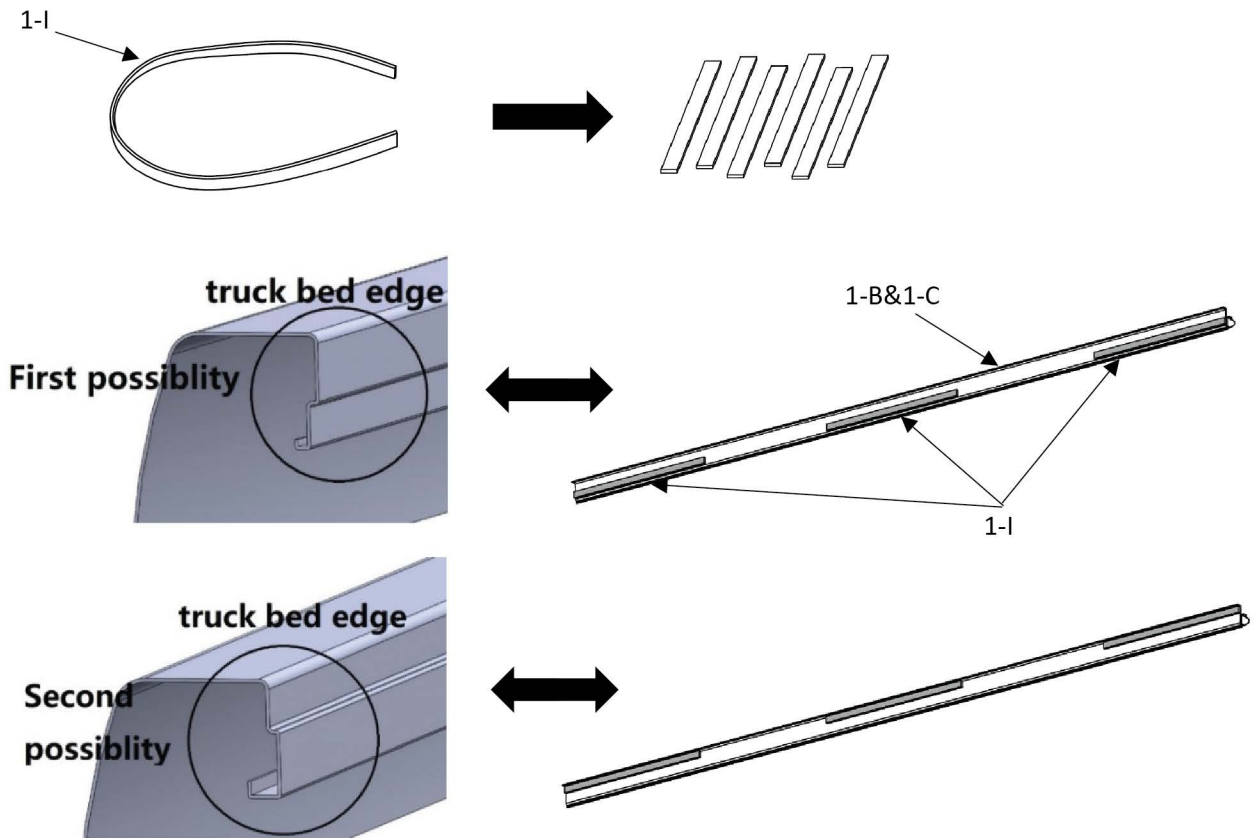

5. Place the side rail on the bed rail, and push it to the front wall of truck bed. Place one clamp at the front of the side rail and one at the rear (please make sure the rear clamps is placed on the position that is closest to tailgate). Tighten the clamps each side.

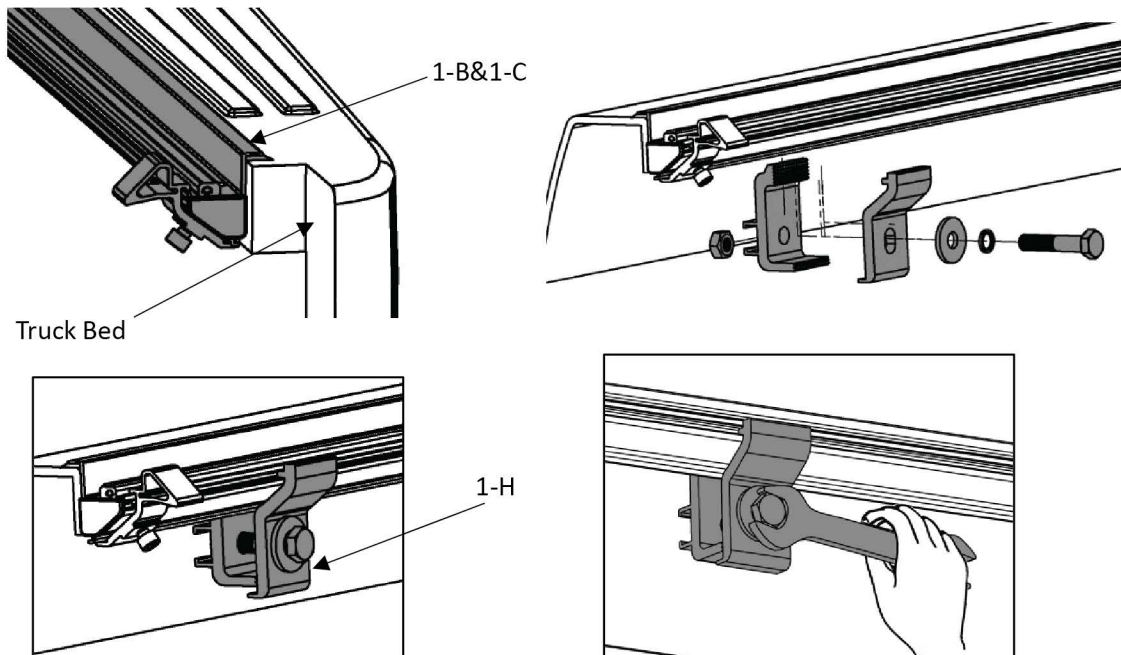

6. If the truck bed side rails are higher than the front edge of the bed, stick the foam seal tape on the front edge of the bed.

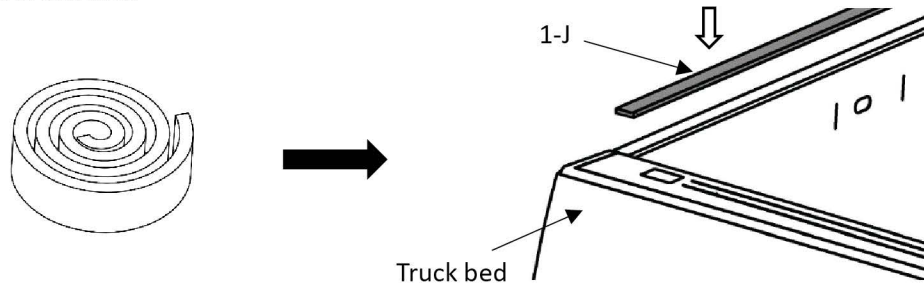

7. Place the tonneau cover over on the front end of truck bed. Ensure the cover is even on all sides and sit firmly on side rails.

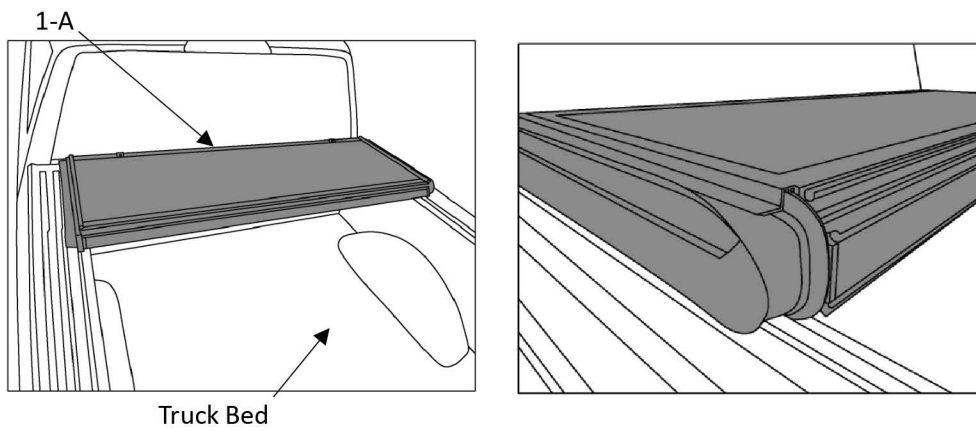

8. Adjust the front support plate(1-F) to correct position, insert the front bolt into the holes on the cover front panel and front support plate. Then tighten the plastic nut under the front support plate.

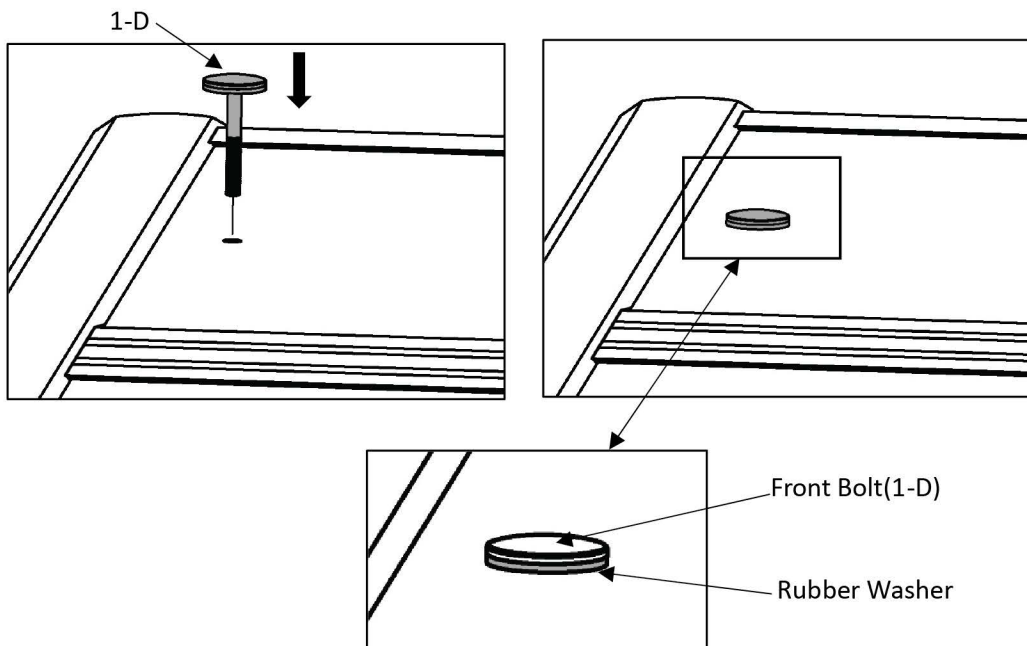

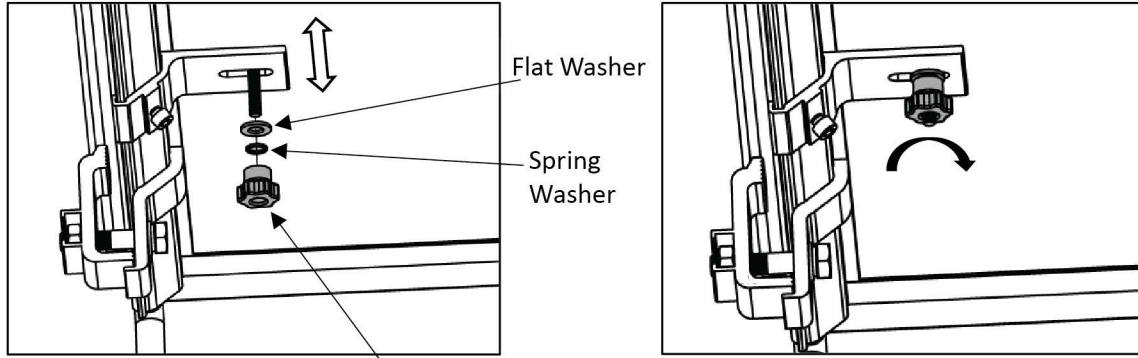

1-D

※ATTENTION: Make sure the Flat Washer and Spring Washer are all placed on bolt before screw the plastic nut on.

9. Unfold the cover, ensure the cover latch touch the side rail locking tongues. If necessary, adjust the Locking Tongue to match the Latch position. Tighten the side rail locking tongues. Lock the cover and close the tailgate.

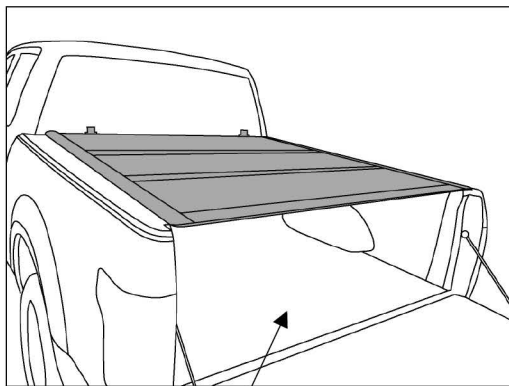

Truck Bed

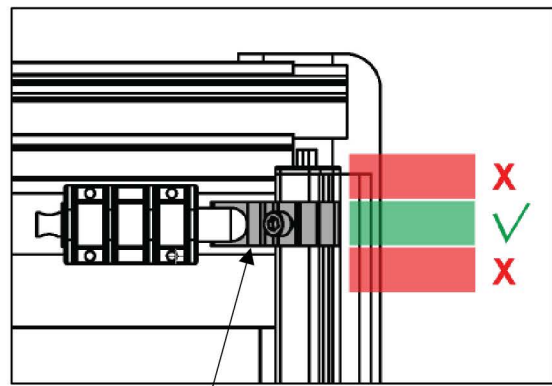

1-G

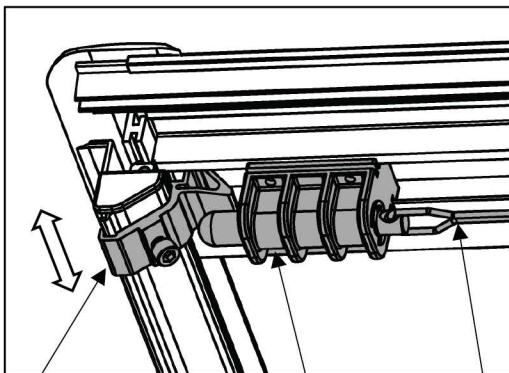

Locking Tongue(1-G)

Latch

Lock Cable

