



**BLACK HORSE
OFF ROAD**

TEL: 1-866-XANATOS

INSTALLATION INSTRUCTIONS

**ARMOUR BULL BAR
FOR 2007-18 SILVERADO1500/SIERRA1500**

PART#AB-GM10

PARTS LIST:

1	Bull Bar	4	10-1.5mm x 25mm Hex Bolts
1	Driver/Left Side Mounting Bracket	4	10mm x 30mm x 2.5mm Flat Washers
1	Passenger/Right Side Mounting Bracket	4	10mm Lock Washers
1	Driver/Left Side Light Bar Bracket	2	8mm Nylon Lock Nuts
1	Passenger/Right Side Light Bar Bracket	2	8-1.25mm x 20mm Hex Bolts
1	Mesh	2	8-1.25mm x 16mm Hex Bolts
1	License Plate Bracket	8	8mm x 24mm x 2mm Flat Washers
2	Rubber Sensor Plugs	4	8mm Lock Washers
2	GM Sensor Wire Harness Extensions	2	8mm Hex Nuts
2	Rubber Grommets	2	6-1.0mm x 20mm Combo Bolts
2	Sensor Clips	2	6-1.0mm x 20mm Button Head Bolts
2	Sensor Seal Washers	4	6mm x 18mm x 1.6mm Flat Washers
2	20mm x 2mm Foam Washers	2	6mm Lock Washers
2	12-1.75mm x 30mm Double Bolt Plates	2	6mm Hex Nuts
2	12-1.75mm x 35mm Single Bolt Plates	4	4mm x 10mm Button Head Bolts (Backup Accessories)
6	12mm x 32mm OD x 3mm Flat Washers	1	Wrench S=4 (Backup Accessories)
6	12-1.75mm Nylon Lock Nuts	1	Wrench S=2.5

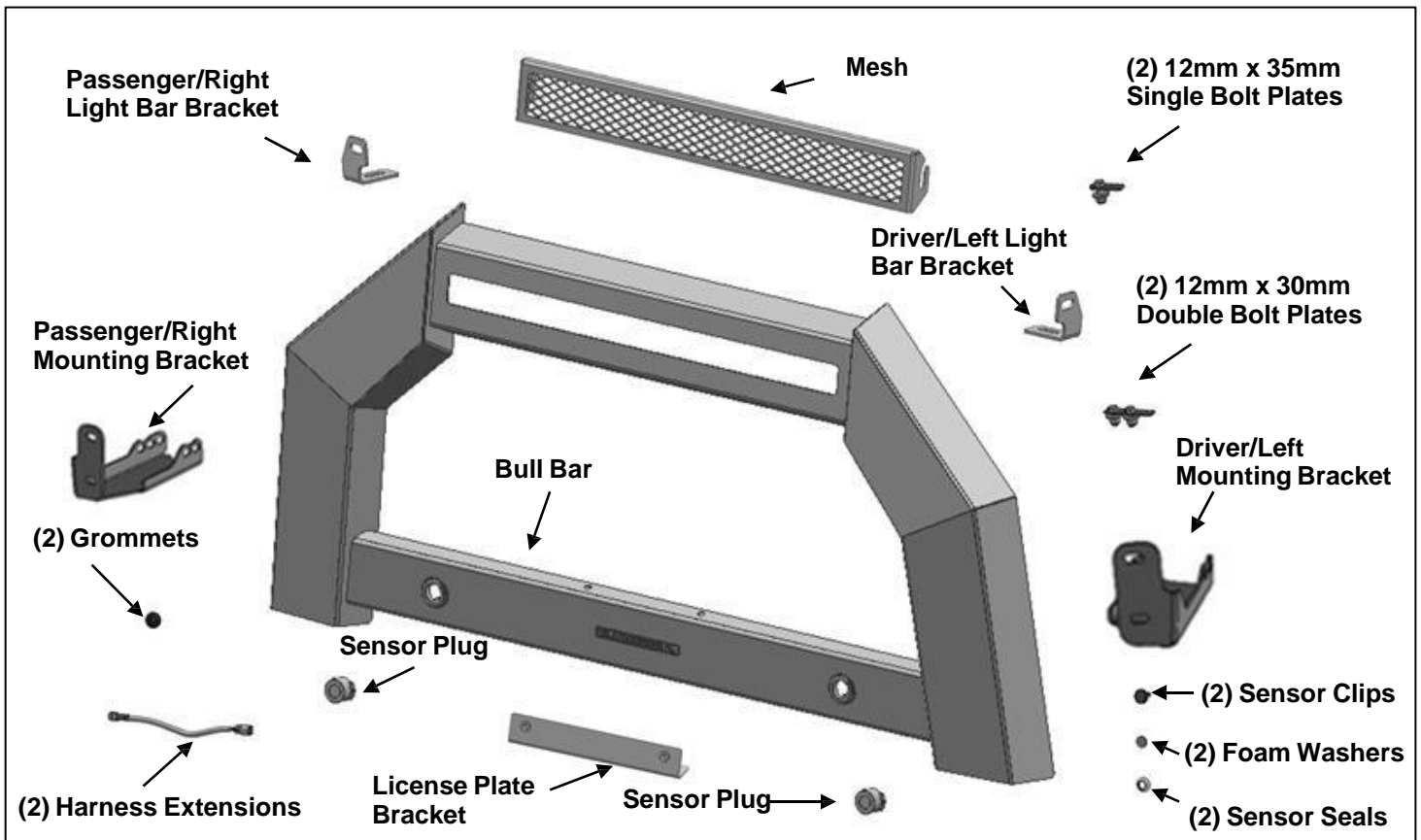

PROCEDURE:

REMOVE CONTENTS FROM BOX AND VERIFY ALL PARTS ARE PRESENT. READ INSTRUCTIONS CAREFULLY. CUTTING MAY BE REQUIRED. INSTALLATION MAY INTERFERE WITH FRONT MOUNTED SENSORS.

1. Start installation from under the front of the vehicle. Determine if the vehicle is equipped with tow hooks, (Figure 1). **IMPORTANT:** Tow hooks cannot be reinstalled with the Bull Bar.

Tow Hook equipped vehicles:

Remove the factory tow hook from the end of each frame channel, **(Figure 1)**. Skip to **Step 2** if tow hooks were accessible and have been removed. **NOTE:** Tow hooks on 2014-on models may be difficult to remove and assistance is highly recommended on these models. The following info only applies to the 2014-on models.

- a. On models with factory fog lights and/or sensors, unplug the harness leading to the bumper. Move all wiring harness away from bumper.
- b. Open the hood and remove the cover between the top of the radiator and the grille. Remove the bolts attaching the bottom of the grille if attached to the cross member. Remove the grille.
- c. **On 2014-15 models only**, from behind the bumper, release the clips and hardware at the ends to remove the plastic body panel, (fascia), on top of the bumper between the bottom of the grille and the top of the bumper, **(Figures 2 & 3)**. Move the fascia to a clean surface.
- d. Remove the outer bumper supports attached to the outside of the frame leading to the ends of the bumper.
- e. Place blocks or jack stands under the front bumper to support it during mounting bolt removal. Once the bumper has been safely supported, from above, remove the factory bumper bolts attaching the bumper to the inner bumper bracket bolted to the end of the frame, **(Figures 2 & 4)**. **WARNING!** Assistance is required to hold the bumper in place during bolt removal to prevent the bumper from falling. Carefully slide the bumper assembly with brackets off of the ends of the frame.
- f. Once bumper has been removed, remove both tow hooks.
- g. Reattach the bumper, fascia panel, (2014-15 models only), grille and cover after both tow hooks have been removed. Check the tow hook openings for Bracket clearance. Trim around openings as required to clear Bracket.
- h. Tighten all factory bumper hardware at this time.
- i. Proceed to **Step 2**.

Vehicles without tow hooks:

- a. Cut out the indented area in both sides of the plastic bumper insert to clear the Brackets as pictured for example, **(Figure 5)**. **IMPORTANT:** Make several small cuts for best fit. Do not cut through the top edge of the panel. **NOTE:** It may be easier to remove the bumper to cut out the openings for the Brackets. Refer to previous Steps for bumper removal.
 - b. Reattach the bumper assembly, (if removed), fascia and grille once openings have been cut out and checked for clearance. Tighten all factory bumper hardware at this time.
2. Select the driver side Mounting Bracket. Insert the Bracket through the opening in the bumper, **(Figure 6)**. Trim the plastic as required to clear the Brackets, **(Figure 11)**.
 3. Line up the holes in the Bracket with the holes in the end of the frame channel for the tow hook, **(Figure 6)**. Select (1) 12mm Double Bolt Plate, **(Figure 7)**. Insert the Bolt Plate into the end of the frame, through the (2) holes in the side of the frame and out through the Bracket, **(Figures 8 & 12)**. Secure the Bracket to the Bolt Plate with (2) 12mm Flat Washers and (2) 12mm Nylon Lock Nuts. Do not fully tighten hardware.
 4. Repeat **Step 3** to install the 12mm x 35mm Single Bolt Plate, **(Figure 9)**, into the remaining hole in the other side of the frame channel and Bracket, **(Figures 10 & 12)**.
 5. **IMPORTANT:** The Brackets are designed with (2) mounting positions to fit multiple models and model years. Most Silverado/Sierra models will use the “back” or “in” mounting position with the Brackets pushed in to install the Bull Bar closer to the bumper, **(Figure 12)**. Move Brackets to the outer position if more clearance is needed between Bull Bar and bumper.
 6. Repeat **Steps 2—5** to install the passenger side Mounting Bracket.
 7. Relocation of front license plate is not required, but strongly recommended.
 - a. Attach the License Plate Bracket to the Bull Bar with (2) 6mm Button Head Bolts, (4) 6mm Flat Washers, (2) 6mm Lock Washers and (2) 6mm Hex Nuts, **(Figure 13)**. Use (2) 6mm Combination Bolts to attach the front license plate to the Bracket, **(Figure 13)**.
 8. **Mesh and LED Light installation, (LED light sold separately)**. Select the driver/left side Light Bar Bracket. Attach the Bracket to the back of the mounting plate on the Bull Bar with (1) 8mm x 20mm Hex Bolt, (2) 8mm Flat Washers, (1) 8mm Lock Washer and (1) 8mm Hex Nut, **(Figure 14)**. Repeat this

step to attach the passenger/right side Light Bar Bracket to the back of the Bull Bar. Do not tighten hardware.

LED Light Installation

- a. Use (2) 8mm x 16mm Hex Bolts, (2) 8mm Lock Washers and (2) 8mm Flat Washers to attach the Light Bar Brackets to the Bull Bar, **(Figure 15)**.
- b. Follow the light manufacturer's instructions to attach the Bull Bar.
- c. Follow light manufacturer's instructions to properly wire the Bull Bar.

Mesh installation

- a. Use (2) 8mm x 16mm Hex Bolts, (4) 8mm Flat Washers, (2) 8mm Lock Washers and (2) 8mm Hex Nuts to attach the Mesh to the inside surface of the Light Bar Brackets, **(Figure 16)**.
- b. Level and adjust the Brackets to the Mesh Panel and fully tighten hardware.

9. Determine if the vehicle is equipped with parking sensors

Models without sensors

- a. Select (2) Sensor Plugs. Insert Rubber Plugs into back of sensor mounts, **(Figure 17)**.

Models with Sensors:

- a. Unplug and remove sensors from factory bumper.
- b. Remove the silicone seal from the end of the sensor. Slide the included larger Sensor Seal over front of sensor, **(Figure 18)**.
- c. Insert sensor with Seal into sensor mount, **(Figure 19)**. **NOTE:** It may be easier to attach the included Wiring Extension to the sensor before installing.
- d. Place Foam Washer over end of sensor. Push Sensor Retaining Clip into sensor mount and lock into mounting holes, **(Figure 19)**.
- e. Repeat previous Steps to install remaining sensor.

10. With assistance, hold the assembled Bull Bar up to the Mounting Brackets. Line up the (2) lower holes in the Uprights with the (2) holes in the Mounting Brackets. Attach the assembled Bull Bar to the Brackets with (4) 10mm Hex Bolts, (4) 10mm Lock Washers and (4) 10mm x 30mm Large Flat Washers, **(Figure 20)**. Do not tighten hardware at this time.

11. Check the Bull Bar alignment with the vehicle and for clearance between the Bull Bar and the bumper. If Bull Bar is too close to or touching bumper, remove the Bull Bar and reinstall the Brackets in the "forward" position away from the bumper, **(Figure 12)**. Adjust as required then fully tighten all hardware at this time.

12. Models with sensors only:

- a. Select (1) Rubber Grommet. Slide the Grommet over the small male plug on the Wiring Extension, **(Figure 21)**.
- b. Push the Grommet into the hole in the bumper.
- c. Plug the Extension into the factory wiring harness for the sensor. Repeat the previous Steps to attach the remaining Wiring Extension.

13. Do periodic inspections to the installation to make sure that all hardware is secure and tight.

To protect your investment, wax this product after installing. Regular waxing is recommended to add a protective layer over the finish. Do not use any type of polish or wax that may contain abrasives that could damage the finish. Mild soap may be used to clean the Bull Bar.

Driver Side Installation Pictured



(Fig 1) Example of low hook

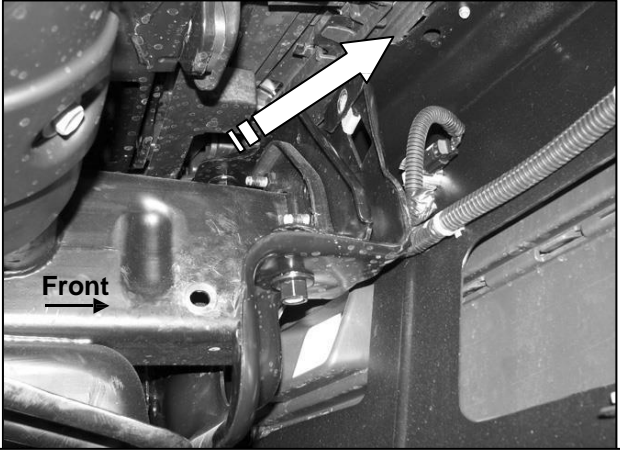

(Fig 2) 2014-15 models, from behind the bumper, remove the clips securing the fascia to the top of the bumper



(Fig 3) Remove screws in wheel opening. Carefully pull to release fender flare and to remove fascia if equipped (arrow)

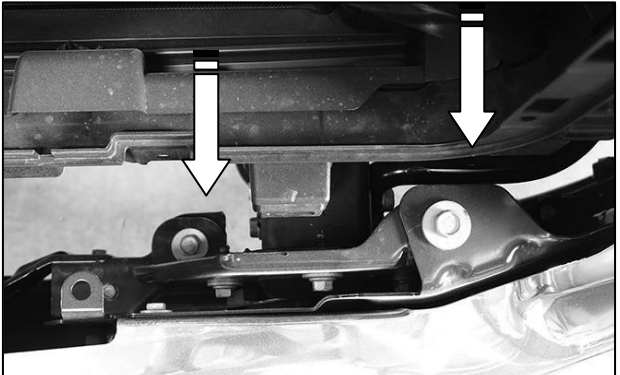

(Fig 4) 2016 model to show bumper bolt locations from above (arrows) with grille removed. 2014-15 models also remove plastic fascia panel to access bumper bolts as necessary

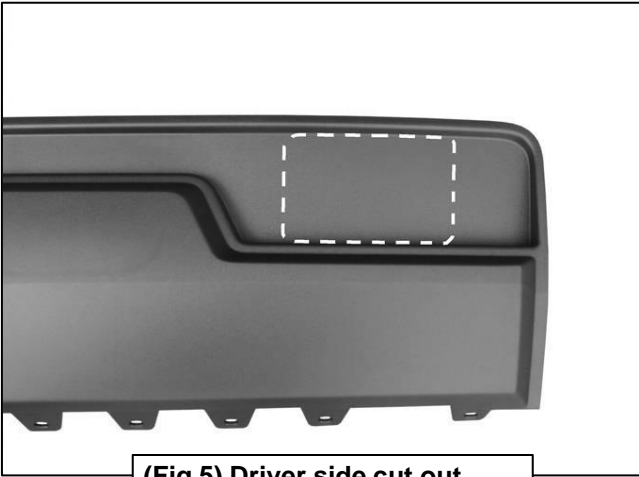

(Fig 5) Driver side cut out illustrated for reference only

Driver Side Installation Pictured

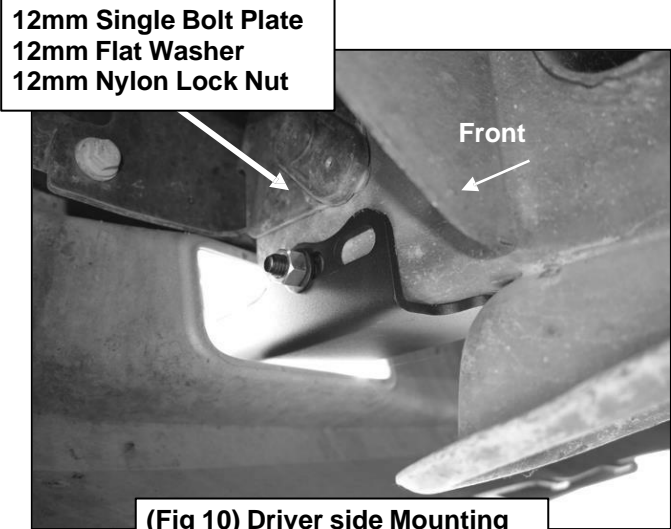
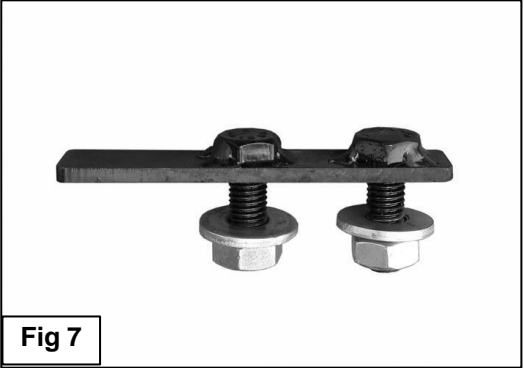
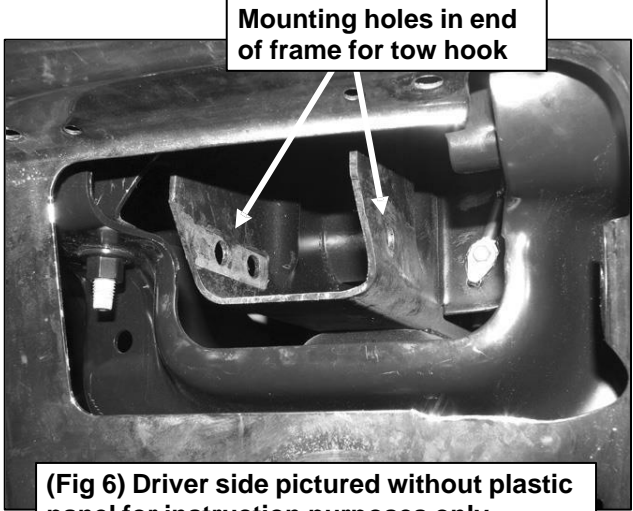

Driver Side Installation Pictured

NOTE: Mounting Brackets installed in the "IN" position to move Bull Bar closer to the bumper. If more clearance is needed, install Brackets in the outer mounting position.

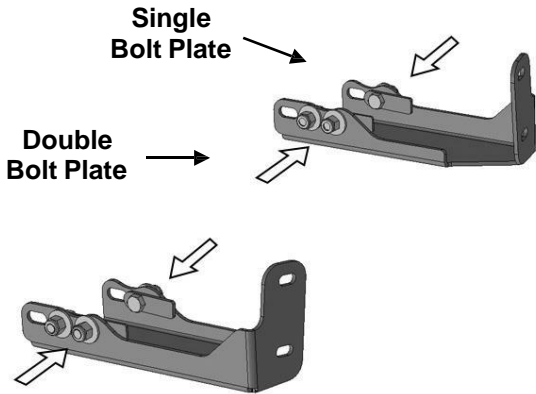

(Fig 12) Typical Silverado/Sierra mounting position with Brackets "IN" toward vehicle

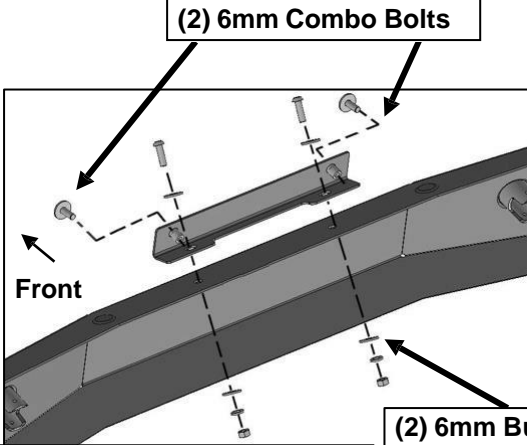

(Fig 13) License Plate Bracket attached to the Bull Bar

- (2) 6mm Button Head Bolts
- (4) 6mm Flat Washers
- (2) 6mm Lock Washers
- (2) 6mm Hex Nuts

- 8mm x 16mm Hex Bolt
- 8mm Lock Washer
- 8mm Flat Washer

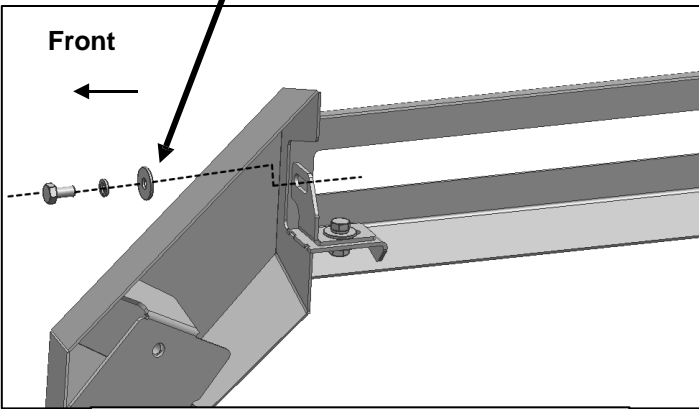

(Fig 15) Driver side light bar Bracket attached to the Bull Bar hardware

- (1) 8mm x 20mm Hex Bolt
- (2) 8mm Flat Washers
- (1) 8mm Lock Washer
- (1) 8mm Hex Nut

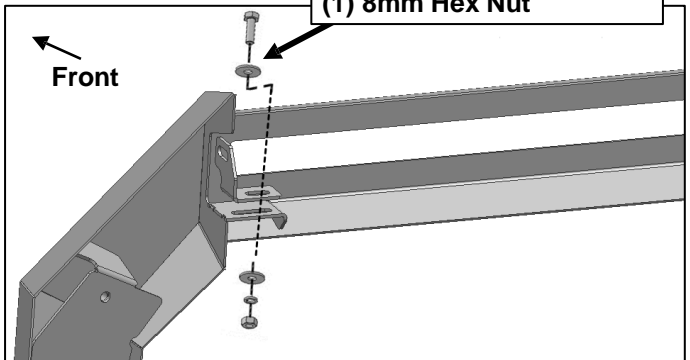

(Fig 14) Driver side light bar Bracket attached to the Bull Bar

- (1) 8mm x 16mm Hex Bolt
- (2) 8mm Flat Washers
- (1) 8mm Lock Washer
- (1) 8mm Hex Nut

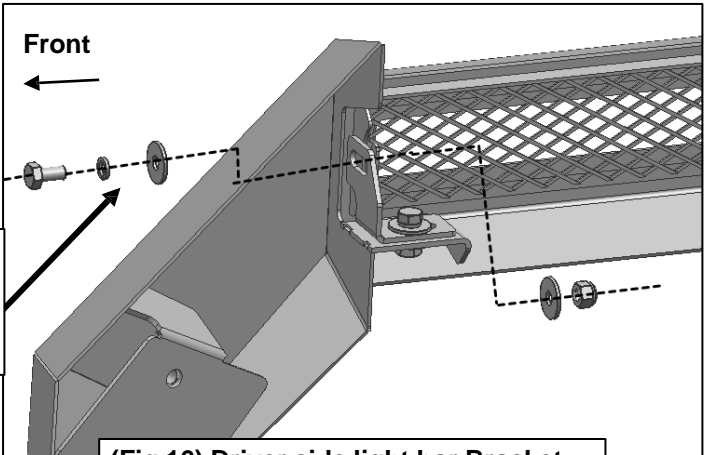

(Fig 16) Driver side light bar Bracket attached to Mesh hardware

Driver Side Installation Pictured

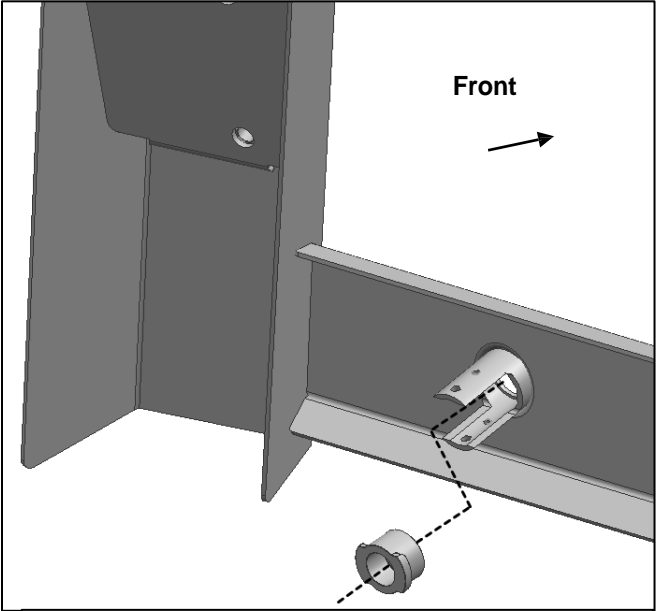

(Fig 17) Attach Sensor Plug into Sensor Sleeve

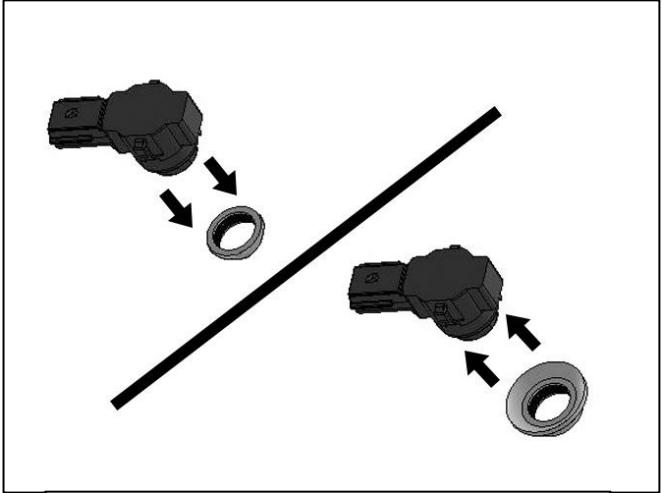

(Fig 18) Remove silicone seal from sensor. Slide large Seal over end of sensor (arrow)

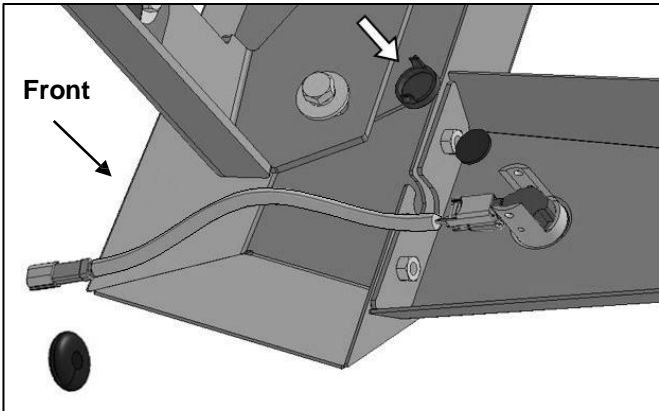

(Fig 19) Slide sensor into sleeve, insert Foam Washer and Clip to lock sensor in sleeve

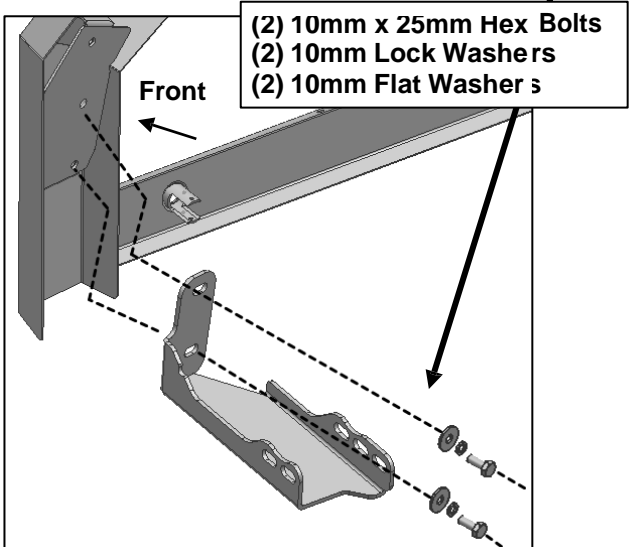

(Fig 20) Attach Bull Bar Bracket to back of Bull Bar



(Fig 21) Models with sensors, slide Grommet over small end of Harness Extension. Push Grommet into hole in bumper and attach to wiring harness