

7929 Lincoln Ave. Riverside, CA 92504
 Phone: 951.689.ICON | Fax: 951.689.1016

PART #	DESCRIPTION
71607	19-23 GM 1500 FRONT 2.5 EXP COILOVER

COMPONENTS INCLUDED	
(1) 174958 19 GM 1500 FRONT 2.5 IR EXP COILOVER (1) 170156 19 GM FRONT BEAUTY PLATE	(1) 294060 EXP COIL MOUNT KIT
HARDWARE INCLUDED	
(1) 605988 EXP COILSEAT SNAP RING SS (1) 257516 EXP COILSEAT	(1) 605968 VIBRATITE BLUE 2ML BULLET
TOOLS REQUIRED	
JACK JACK STANDS RETAINING RING PLIERS TORQUE WRENCH COIL SPRING COMPRESSOR 3/4" SOCKET / WRENCH 7MM SOCKET / WRENCH	9MM SOCKET / WRENCH 10MM SOCKET / WRENCH 15MM SOCKET / WRENCH 18MM SOCKET / WRENCH 21MM SOCKET / WRENCH PRY BAR
TECH NOTES	
<p>1. YOUR ICON SHOCK ASSEMBLIES COME FACTORY CHARGED TO 250 PSI. RELEASING NITROGEN PRESSURE MAY LEAD TO SHOCK MALFUNCTION AND REDUCED RIDE QUALITY. FAILURE CAUSED BY LOW NITROGEN PRESSURE IS NOT COVERED UNDER ICON'S WARRANTY POLICY.</p> <p>2. NOT COMPATIBLE WITH MODELS EQUIPPED WITH ADAPTIVE RIDE CONTROL.</p> <p>3. NOT COMPATIBLE WITH ZR2 AND AT4X SUB MODELS.</p> <p>4. NOT COMPATIBLE WITH TRAIL BOSS AND AT4 MODELS.</p> <p>5. SEE PAGE 7 FOR EXP SHOCK GROOVE SPECS.</p>	



WARNING!
<p>** READ ALL INSTRUCTIONS THOROUGHLY FROM START TO FINISH BEFORE BEGINNING INSTALLATION! IF THESE INSTRUCTIONS ARE NOT PROPERLY FOLLOWED SEVERE FRAME, SUSPENSION AND TIRE DAMAGE MAY RESULT TO THE VEHICLE!</p> <p>** ICON VEHICLE DYNAMICS RECOMMENDS THAT YOU EXERCISE EXTREME CAUTION WHEN WORKING UNDER A VEHICLE THAT IS SUPPORTED WITH JACK STANDS.</p> <p>** ICON VEHICLE DYNAMICS RECOMMENDS ALL INSTALLATION TO BE PERFORMED BY A PROFESSIONAL SHOP/SERVICE TECHNICIAN. PRODUCT FAILURE CAUSED BY IMPROPER INSTALLATION WILL NOT BE COVERED UNDER ICON'S WARRANTY POLICY.</p>

INSTALLATION

- Lift vehicle and securely place heavy duty jack stands under the manufacturer recommended lifting locations for the front of the vehicle. Take care when lifting the vehicle, and allow 3-4" of ground clearance from the tire. Remove front tires. NEVER WORK UNDER AN UNSUPPORTED VEHICLE.
- Starting on the driver side, remove the five 10mm bolts that hold the speed sensor and line, brake line, and brake pad sensor wire from the knuckle (passenger side only have four bolts). Move the loose the wiring to the back, along the frame. [FIGURE 1 & 2]

FIG.1



FIG.2



3. Disconnect the sway bar link from the sway bar using a 9mm and 18mm. **[FIGURE 3]**

FIG.3



4. Support the lower control arm with a jack. Remove the three 18mm nuts from the top of the coilover mount. The wiring harness can be pried off the stud with a pry bar. On the passenger side, the inner nut can be accessed from under the hood. **[FIGURE 4]**

FIG.4



5. Using a 15mm, remove the two bolts that hold the coilover to the lower control arm. **[FIGURE 5]**

FIG.5



6. Remove the tie rod from the knuckle using a 21mm and a ball joint separator. A 10mm may be needed to hold the ball stud from turning while removing the nut.

7. Remove the upper control arm ball joint from the knuckle using an 18mm and a ball joint separator. Keep the nut while breaking the stud loose from the knuckle. Once the stud is loose, remove the nut and support the knuckle so that the CV axle does not pull apart or over-extend the brake hose. **[FIGURE 6 & 7]**

FIG.6

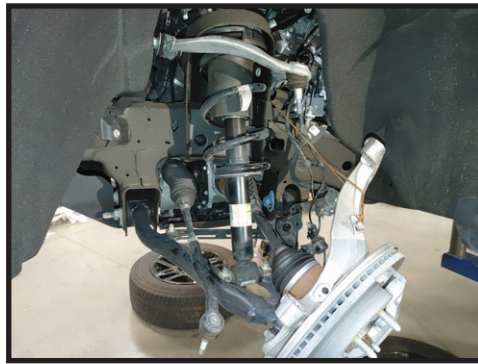

FIG.7



8. Once the stud is loose, remove the nut and support the knuckle so that the CV axle does not pull apart or over-extend the brake hose. [FIGURE 8]

FIG.8



9. Remove the coil-over from the vehicle now. Lower the jack enough to pull the bottom of the coilover from of the arm first then slide it out completely. [FIGURE 9]

FIG.9



10. Before removing the spring, mark the upper mount, coil isolator and spring with a marker. Make sure you orient the front of the coilover upper mount so you know which way to install it onto the ICON coilover. Using a spring compressor, remove the factory spring and upper mount from the coilover. [FIGURE 10 & 11]

FIG.10



FIG.11



11. Use an 18mm to remove the center nut on top of the coilover, once you have compressed the spring some. Be careful as the spring is under a lot of compression and the shock can shoot out when the nut is removed. Stand clear.

12. With the upper coilover disassembled, take the aluminum upper mount and drill out the center hole to 1/2". Then reinstall it onto the spring isolator, making sure the marks are aligned. [FIGURE 12 & 13]

FIG.12

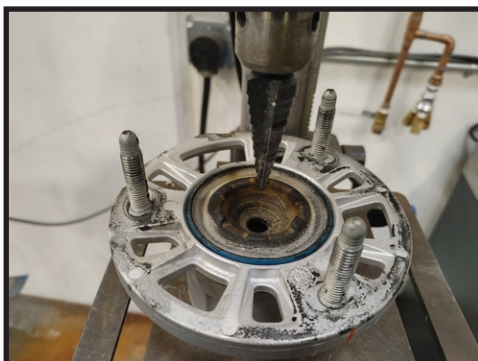

FIG.13



13. Grab the new ICON coilover and install the snap ring, coil seat and OEM GM foam bump stop. The snap ring groove lift heights can be found at the end of the instructions. [FIGURE 14 & 15]

FIG.14



FIG.15



14. Now is a good time to rotate the lower bar-pin into position as shown. The coilover needs to be oriented so that the coilover is closer to the front of the vehicle, leaving plenty of space for the axle. Rotating the bar pin with a wrench or bolts threaded into the holes will help to align the bolts once installed. Install the OEM bump stop as shown. [FIGURE 16 & 17]

FIG.16



FIG.17

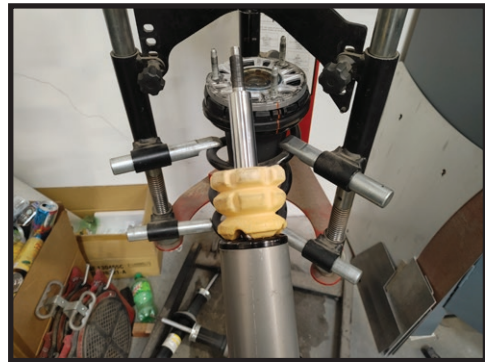

15. Install the ICON coilover into the OEM spring, align the threaded shaft through the upper mount and thread the nut on. Align the lower bar pin and upper mount as shown for easy install. Tighten down nut using a 3/4" [Torque to 60 ft-lbs] (Passenger shock pictured). Install the beauty plate onto the upper mount. [FIGURE 18 & 19]

FIG.18

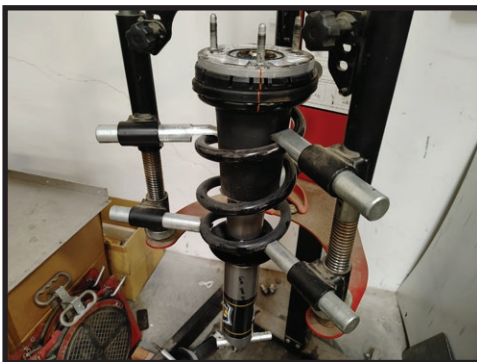
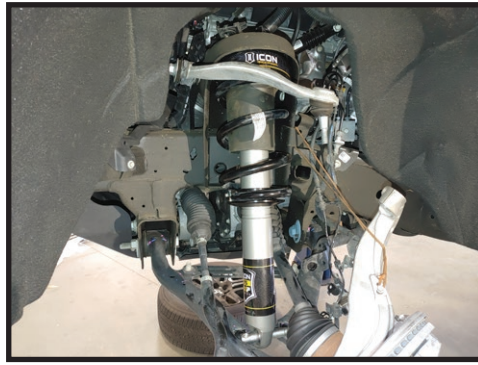

FIG.19



16. Install the coilover onto the truck now. Insert the upper mount into position and then the lower bar pin into the arm. Use thread locker on the OEM nuts and torque to 30 ft-lbs. Use Thread locker on the OEM bolts and torque to 40 ft-lbs. [FIGURE 20]

FIG.20



17. Reinstall the upper arm, tie rod, sway bar link and wires and hoses in reverse order of removal.

18. Now repeat the process on the passenger side.

19. Enjoy your new ICON coilovers!

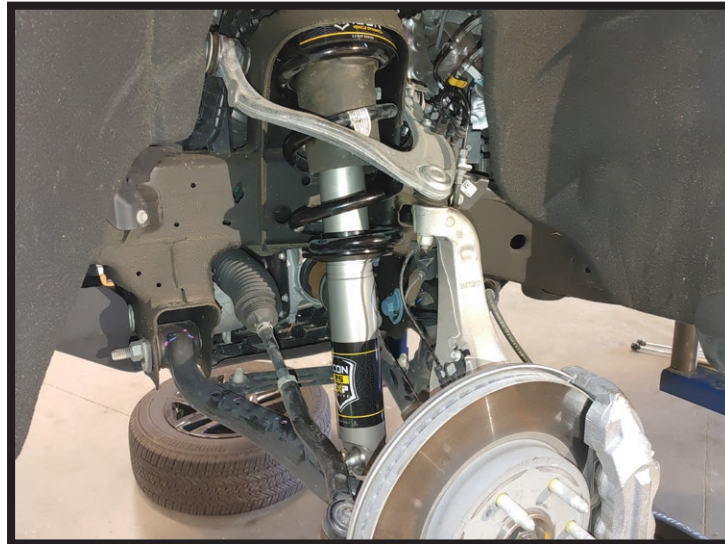

VERIFY ALL FASTENERS ARE PROPERLY TORQUED BEFORE DRIVING VEHICLE.

RETORQUE ALL NUTS, BOLTS AND LUGS AFTER 100 MILES AND PERIODICALLY THEREAFTER.

2.5 VS SERIES SHOCK & COILOVER TECHNICAL INFORMATION

MAINTENANCE

ICON shock absorbers are a high quality rebuildable race style shock absorber designed for optimal performance. With a unit of this caliber on your vehicle, routine maintenance is required to keep them looking and operating in like new condition. Residual oil and assembly lube may be present at all seal paths from the factory out of the box and is considered normal. Pooling of oil however is not acceptable at any time and one should contact the ICON dealer where purchased.

BELOW ARE GUIDELINES BASED ON HOW YOU USE YOUR VEHICLE BUT YOUR MILEAGE MAY VARY:

STREET USE:

- Send in for factory servicing every 40,000 miles or if a leak develops, ride quality decreases, or they begin to make excessive noise.
- Remove any buildup of road salt, mud, or debris from shocks and coil springs anytime accrued
- Clean with mild soap and water with each oil change or anytime you notice build up.
- Wax the cylinders yearly with automotive wax to prevent corrosion.
- Check nitrogen pressure yearly. (252004 charge needle assembly available at any ICON distributor)
- Check bearings for excessive wear yearly.
- DO NOT apply any type of lube to the upper and lower bearings.

STREET/DIRT:

- Send in for factory servicing every 15,000 miles or if a leak develops, ride quality decreases, or they begin to make excessive noise.
- Clean with mild soap and water with each oil change, offroad trip, or anytime you notice build up.
- Wax the cylinders yearly with automotive wax to prevent corrosion.
- Check nitrogen pressure each dirt outing. (252004 charge needle assembly available at any ICON distributor)
- Check bearings for excessive wear yearly.
- DO NOT apply any type of lube to the upper and lower bearings.

DIRT USE:

- Send in for factory servicing every 1,000 miles.
- Check nitrogen pressure each outing. (252004 charge needle assembly available at any ICON distributor)
- Remove any buildup of mud or debris from shocks and coil springs after every outing.

SELF-SERVICE:

- Contact ICON for service kits & tools at (951) 689-4266.

PRODUCT REGISTRATION

Please visit: <http://www.iconvehicledynamics.com/tech-support/registration/> to register your product.

ICON VEHICLE DYNAMICS SHOCK ABSORBER WARRANTY

This shock absorber has a 1 year warranty against any manufacturer's defects. If a shock fails within the initial year of ownership, the shock must be shipped to ICON Vehicle Dynamics for inspection and service. If a shock is inspected and it has been determined the shock failed due to neglect, damage caused by improper installation or any other reason besides "normal wear and tear", the owner of said shock is responsible for all service costs. This includes labor, parts, and shipping.

ICON Vehicle Dynamics warrants to the original retail purchaser who owns the vehicle on which the product was originally installed. ICON Vehicle Dynamics does not warrant the product for finish, alterations, modifications and/or installation contrary to ICON Vehicle Dynamics instructions. ICON Vehicle Dynamics products are not designed, nor are they intended to be installed on vehicles used in race applications, for racing purposes or for similar activities. (A "race" is defined as any contest between two or more vehicles, or a contest of one or more vehicles against the clock, whether or not such contest is for a prize). This warranty does not include coverage for police or taxi vehicles, race vehicles, or vehicles used for government or commercial purposes. Also excluded from this warranty are sales outside of the United States of America and Canada.

ICON Vehicle Dynamics' obligation under this warranty is limited to the repair or replacement, at ICON Vehicle Dynamics' discretion, of the defective product. Any and all costs of removal, installation or re-installation, freight charges and incidental or consequential damages are expressly excluded from this warranty. Items that are subject to wear are not considered defective when worn and are not covered.

ICON Vehicle Dynamics components must be installed as a complete kit as shown in our current application guide. Any substitutions or exemptions of required components will immediately void the warranty. Some finish damage may happen to parts during shipping and is not covered under warranty.

This warranty is expressly in lieu of all other warranties expressed or implied. This warranty shall not apply to any product that has been improperly installed, modified or customized subject to accident, negligence, abuse or misuse.

To send a shock in for warranty please visit our website <http://www.iconvehicledynamics.com/tech-support/shock-service/>



ICON VEHICLE DYNAMICS®
PERFORMANCE SUSPENSION SYSTEMS AND SHOCK ABSORBERS

7929 Lincoln Ave. Riverside, CA 92504 Phone: 951.689.ICON Fax: 951.689.1016
www.iconvehicledynamics.com



FOLLOW US ON FACEBOOK!



ICON GM 1500 FRONT EXP GROOVE SPECS

FENDER TO HUB MEASUREMENT

FACTORY
RIDE HEIGHT: 22-1/8"

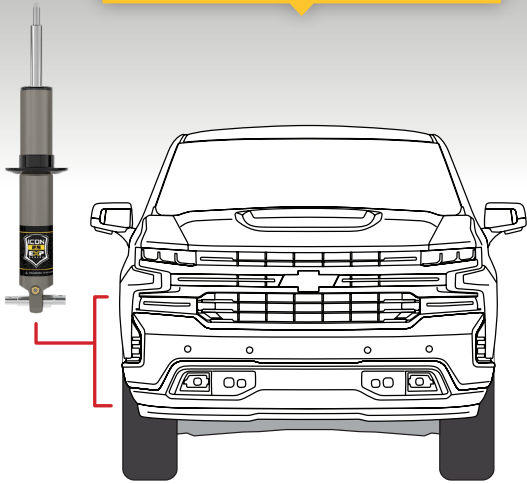

MAXIMUM
RIDE HEIGHT: *25-1/8"
25-3/4"

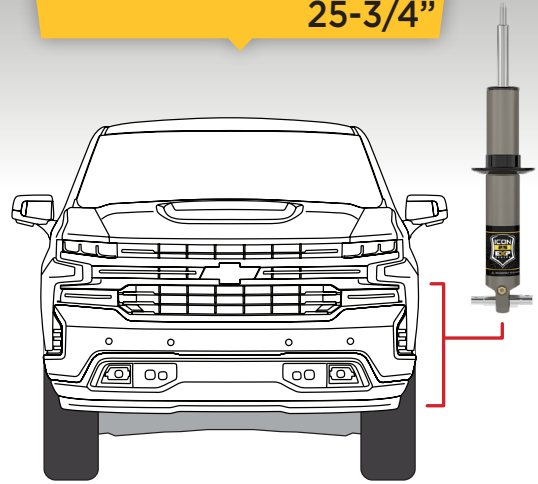

GROOVE 1:

GROOVE 2:

GROOVE 3:

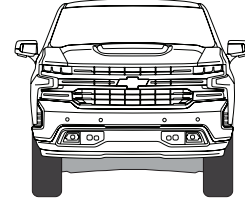
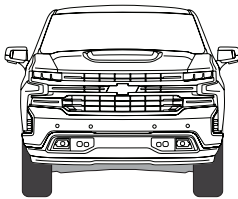

1-3/4" LIFT*
2-3/8" LIFT

2-3/8" LIFT*
3" LIFT

3" LIFT*
3-3/4" LIFT

GROOVE 1 & 2

GROOVE 3



*for diesel equipped vehicles.

7929 Lincoln Ave. Riverside, CA 92504
Phone: 951.689.ICON Fax: 951.689.1016

PART #	DESCRIPTION
77703P	2019-UP GM 1500 REAR 2.5 VS PB PAIR

COMPONENTS INCLUDED	
(2) 174957 19-UP GM 1500 REAR 2.5 PB	
HARDWARE INCLUDED	
N/A	
TOOLS REQUIRED	
JACK JACK STANDS BARREL SANDER	TORQUE WRENCH 21MM SOCKET / WRENCH
TECH NOTES	
<p>1. YOUR ICON SHOCK ASSEMBLIES COME FACTORY CHARGED TO 250 PSI. RELEASING NITROGEN PRESSURE MAY LEAD TO SHOCK MALFUNCTION AND REDUCED RIDE QUALITY. FAILURE CAUSED BY LOW NITROGEN PRESSURE IS NOT COVERED UNDER ICON'S WARRANTY POLICY.</p> <p>2. ICON RECOMMENDS MOUNTING THE SHOCKS WITH THE SHAFT FACING UPWARD. MOUNTING THEM THIS WAY REDUCES THE AMOUNT OF SANDING THAT NEEDS TO BE DONE ON THE SHOCK MOUNTS.</p>	



WARNING!
<p>** READ ALL INSTRUCTIONS THOROUGHLY FROM START TO FINISH BEFORE BEGINNING INSTALLATION! IF THESE INSTRUCTIONS ARE NOT PROPERLY FOLLOWED SEVERE FRAME, SUSPENSION AND TIRE DAMAGE MAY RESULT TO THE VEHICLE!</p> <p>** ICON VEHICLE DYNAMICS RECOMMENDS THAT YOU EXERCISE EXTREME CAUTION WHEN WORKING UNDER A VEHICLE THAT IS SUPPORTED WITH JACK STANDS.</p> <p>** ICON VEHICLE DYNAMICS RECOMMENDS ALL INSTALLATION TO BE PERFORMED BY A PROFESSIONAL SHOP/SERVICE TECHNICIAN. PRODUCT FAILURE CAUSED BY IMPROPER INSTALLATION WILL NOT BE COVERED UNDER ICON'S WARRANTY POLICY.</p>

INSTALLATION

- Using a properly rated jack, raise the rear of the vehicle and support the frame rails with jack stands. Ensure the jack stands are secure and set properly before lowering the jack. NEVER WORK UNDER AN UNSUPPORTED VEHICLE. Remove the rear wheels.
- Remove the OEM rear shocks using a 21mm. [FIGURE 1 & 2]

FIG.1



FIG.2



3. Slightly sand the lower passenger shock mount for adequate top cap clearance. Approximately 1/16" inch is all that is necessary. Install the upper bolt first with the wide spacer to the inside, spacing the shock out towards the frame using a 21mm. [Torque to factory spec] [FIGURE 3 & 4]

FIG.3



FIG.4



4. Install the lower shock bolt using a 21mm. It helps to have the suspension fully extended for this step. [Torque to factory spec]

5. Check to make sure that the reservoir has adequate clearance.

6. On the driver side, the shock reservoir should be oriented between the exhaust (for dual exhaust) and brake line. [FIGURE 5 & 6]

FIG.5



FIG.6



7. On the passenger side, the shock reservoir should be between the exhaust hanger and the brake line protector on the front of the differential tube. [FIGURE 7 & 8]

FIG.7



FIG.8

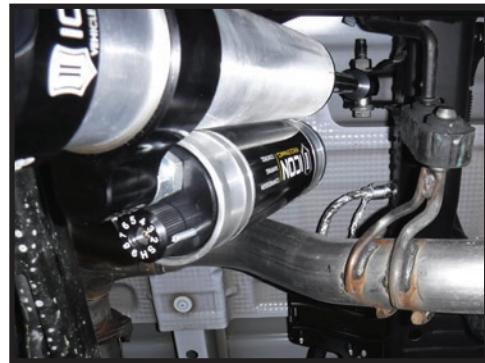

8. Install the wheels and lower vehicle to the ground. [Torque lugs to factory spec]

VERIFY ALL FASTENERS ARE PROPERLY TORQUED BEFORE DRIVING VEHICLE.

RETORQUE ALL NUTS, BOLTS AND LUGS AFTER 100 MILES AND PERIODICALLY THEREAFTER.

ICON VEHICLE DYNAMICS LIABILITY DISCLAIMER

ICON does not make any representations or warranties regarding the fitness of any ICON product for a particular installation or conformance of any ICON product with a particular vehicle application. Installation of any ICON suspension system is at the sole discretion of the end user and in making a purchase of any ICON suspension system, the purchaser assumes the responsibility and liability for any and all damage or injury, of any kind or nature whatsoever, caused by, resulting from, arising out of, or occurring in connection with the use or installation of any ICON suspension system. ICON is not liable for and specifically disavows any installation that is not in conformance with original equipment manufacturer's recommendations or instructions. Purchaser agrees that in the event of any claim or lawsuit arising out of the installation or use of an ICON suspension system, purchaser shall indemnify and hold harmless ICON, its agents, employees, officers and owners from and against any and all loss, expense, damage or injury that ICON may sustain as the result of such claim. [If applicable, ICON defers to and recommends recalibration of any/all vehicle stability systems after suspension installation.]

2.5 VS SERIES SHOCK & COILOVER TECHNICAL INFORMATION

MAINTENANCE

ICON shock absorbers are a high quality rebuildable race style shock absorber designed for optimal performance. With a unit of this caliber on your vehicle, routine maintenance is required to keep them looking and operating in like new condition. Residual oil and assembly lube may be present at all seal paths from the factory out of the box and is considered normal. Pooling of oil however is not acceptable at any time and one should contact the ICON dealer where purchased.

BELOW ARE GUIDELINES BASED ON HOW YOU USE YOUR VEHICLE BUT YOUR MILEAGE MAY VARY:

STREET USE:

- Send in for factory servicing every 40,000 miles or if a leak develops, ride quality decreases, or they begin to make excessive noise.
- Remove any buildup of road salt, mud, or debris from shocks and coil springs anytime accrued
- Clean with mild soap and water with each oil change or anytime you notice build up.
- Wax the cylinders yearly with automotive wax to prevent corrosion.
- Check nitrogen pressure yearly. (252004 charge needle assembly available at any ICON distributor)
- Check bearings for excessive wear yearly.
- **DO NOT** apply any type of lube to the upper and lower bearings.

STREET/DIRT:

- Send in for factory servicing every 15,000 miles or if a leak develops, ride quality decreases, or they begin to make excessive noise.
- Clean with mild soap and water with each oil change, offroad trip, or anytime you notice build up.
- Wax the cylinders yearly with automotive wax to prevent corrosion.
- Check nitrogen pressure each dirt outing. (252004 charge needle assembly available at any ICON distributor)
- Check bearings for excessive wear yearly.
- **DO NOT** apply any type of lube to the upper and lower bearings.

DIRT USE:

- Send in for factory servicing every 1,000 miles.
- Check nitrogen pressure each outing. (252004 charge needle assembly available at any ICON distributor)
- Remove any buildup of mud or debris from shocks and coil springs after every outing.

SELF-SERVICE:

- Contact ICON for service kits & tools at (951) 689-4266.

PRODUCT REGISTRATION

Please visit: <http://www.iconvehicledynamics.com/tech-support/registration/> to register your product.

ICON VEHICLE DYNAMICS SHOCK ABSORBER WARRANTY

This shock absorber has a 1 year warranty against any manufacturer's defects. If a shock fails within the initial year of ownership, the shock must be shipped to ICON Vehicle Dynamics for inspection and service. If a shock is inspected and it has been determined the shock failed due to neglect, damage caused by improper installation or any other reason besides "normal wear and tear", the owner of said shock is responsible for all service costs. This includes labor, parts, and shipping.

ICON Vehicle Dynamics warrants to the original retail purchaser who owns the vehicle on which the product was originally installed. ICON Vehicle Dynamics does not warrant the product for finish, alterations, modifications and/or installation contrary to ICON Vehicle Dynamics instructions. ICON Vehicle Dynamics products are not designed, nor are they intended to be installed on vehicles used in race applications, for racing purposes or for similar activities. (A "race" is defined as any contest between two or more vehicles, or a contest of one or more vehicles against the clock, whether or not such contest is for a prize). This warranty does not include coverage for police or taxi vehicles, race vehicles, or vehicles used for government or commercial purposes. Also excluded from this warranty are sales outside of the United States of America and Canada.

ICON Vehicle Dynamics' obligation under this warranty is limited to the repair or replacement, at ICON Vehicle Dynamics' discretion, of the defective product. Any and all costs of removal, installation or re-installation, freight charges and incidental or consequential damages are expressly excluded from this warranty. Items that are subject to wear are not considered defective when worn and are not covered.

ICON Vehicle Dynamics components must be installed as a complete kit as shown in our current application guide. Any substitutions or exemptions of required components will immediately void the warranty. Some finish damage may happen to parts during shipping and is not covered under warranty.

This warranty is expressly in lieu of all other warranties expressed or implied. This warranty shall not apply to any product that has been improperly installed, modified or customized subject to accident, negligence, abuse or misuse.

To send a shock in for warranty please visit our website <http://www.iconvehicledynamics.com/tech-support/shock-service/>



ICON VEHICLE DYNAMICS®
PERFORMANCE SUSPENSION SYSTEMS AND SHOCK ABSORBERS

7929 Lincoln Ave. Riverside, CA 92504 Phone: 951.689.ICON Fax: 951.689.1016
www.iconvehicledynamics.com



FOLLOW US ON FACEBOOK!



7929 Lincoln Ave. Riverside, CA 92504
Phone: 951.689.ICON Fax: 951.689.1016

PART #	DESCRIPTION
78720DJ	2019-UP GM 1500 BILLET UCA KIT

COMPONENTS INCLUDED

(1) 177515 19-UP GM 1500 BILLET UCA (DRVR) (1) 177516 19-UP GM 1500 BILLET UCA (PASS)

HARDWARE INCLUDED

(2) 155110 -O32 O-RING NITRILE (4) 295511 ROD END JM12T F1 FIT
 (2) 157507 BILLET UCA DUST COVER (4) 297010 HEIM SPACER JM12 X 14MM X 1.875
 (2) 157517BJ DELTA JOINT (8) 605002 6-32 X .500 SHCS 18-8
 (4) 157520 L-R ADJ SLEEVE 1.00-14L / .75-16 (8) 605145 3/8-16 X 1.000 12PT
 (4) 197503 HEIM SPACER RSMX12 X 14MM X 2.775 (1) 605968 BLUE THREAD LOCKER 2ML BULLET

TOOLS REQUIRED

JACK 3/8" 12PT SOCKET / WRENCH
 JACK STANDS 10MM SOCKET / WRENCH
 GRINDER W/ CUT-OFF WHEEL 18MM SOCKET / WRENCH
 TORQUE WRENCH 21MM SOCKET / WRENCH

TECH NOTES

1. ICON UPPER CONTROL ARMS ALLOW FOR ADDITIONAL DROOP TRAVEL WHEN PAIRED WITH ICON'S EXTENDED TRAVEL COILOVERS (PN: 71606, 71656, OR 71656C).
2. DO NOT EXCEED 1.875" ADJUSTMENT FROM THE CENTER OF THE ROD END TO THE EDGE OF THE BILLET UPPER CONTROL ARM. FAILURE CAUSED BY EXCESSIVE ADJUSTMENT WILL NOT BE COVERED UNDER ICON'S WARRANTY POLICY.
3. ALL ICON UPPER CONTROL ARMS HAVE BEEN ENGINEERED TO ALLOW FOR THE MOST POSSIBLE CASTER, WHILE STILL ALLOWING THE VEHICLE TO BE PROPERLY ALIGNED. NOTIFY YOUR PROFESSIONAL ALIGNMENT SHOP OF THIS INFORMATION SO THAT MAXIMUM RIDE QUALITY CAN BE ACHIEVED.
4. ICON DELTA JOINTS ARE PRE-GREASED FROM THE FACTORY. ICON RECOMMENDS GREASING THE DELTA JOINT EVERY 3,000 MILES (OR EVERY OIL CHANGE). ADD NEW GREASE UNTIL ALL OF THE OLD GREASE IS EXPELLED FROM THE BOTTOM OF THE DELTA JOINT ASSEMBLY, WIPE AWAY EXCESS WITH A RAG OR SHOP TOWEL.

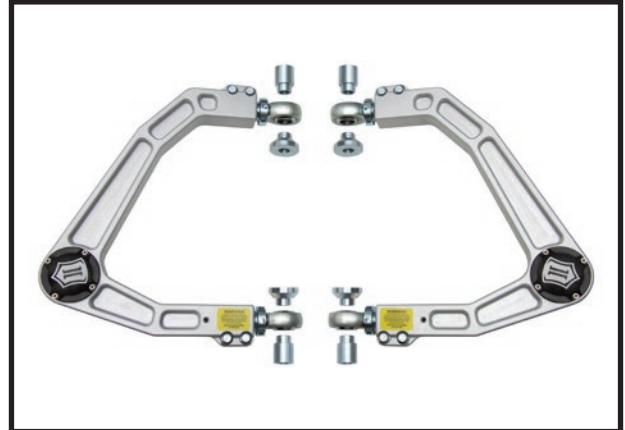

WARNING!

**** READ ALL INSTRUCTIONS THOROUGHLY FROM START TO FINISH BEFORE BEGINNING INSTALLATION! IF THESE INSTRUCTIONS ARE NOT PROPERLY FOLLOWED SEVERE FRAME, SUSPENSION AND TIRE DAMAGE MAY RESULT TO THE VEHICLE!**

**** ICON VEHICLE DYNAMICS RECOMMENDS THAT YOU EXERCISE EXTREME CAUTION WHEN WORKING UNDER A VEHICLE THAT IS SUPPORTED WITH JACK STANDS.**

**** ICON VEHICLE DYNAMICS RECOMMENDS ALL INSTALLATION TO BE PERFORMED BY A PROFESSIONAL SHOP/SERVICE TECHNICIAN. PRODUCT FAILURE CAUSED BY IMPROPER INSTALLATION WILL NOT BE COVERED UNDER ICON'S WARRANTY POLICY.**

INSTALLATION

1. Using a properly rated jack, raise the front of the vehicle and support the frame rails with jack stands. Ensure the jack stands are secure and set properly before lowering the jack. NEVER WORK UNDER AN UNSUPPORTED VEHICLE. Remove the front wheels.
2. Remove the ABS line bracket from the upper control arm (UCA) using a 10mm. [FIGURE 1]



FIG.1



FIG.2

3. Loosen the taper on the upper ball joint and the tie rod end using an 18mm socket/wrench. Use a hammer to separate the upper ball joint taper and tie rod end. Take care not to damage the threads. Support the spindle (using safety wire, tie down, etc) so that it does not overextend the CV joints when detached. [FIGURE 2]
4. With the UCA detached from the spindle, begin to loosen the UCA from its mounts in the frame using a 21mm wrench and socket. Once completed, remove the factory UCA's from the vehicle.

5. Cut the factory droop stop off of the side of the coil bucket. Paint the bare metal to prevent corrosion. [FIGURE 3 & 4]

FIG.3



FIG.4



6. Each UCA is clearly labeled which side and direction it should be installed.

7. Insert the supplied heim spacers as shown. Slide the ICON UCA into place and fasten using the factory hardware. [FIGURE 5]

FIG.5

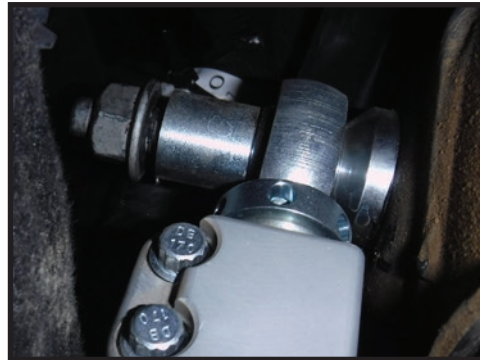

8. Hand tighten OEM hardware using (2) 21mm. [Torque to factory spec]

9. Take care when inserting tapered pin into the spindle to not damage the threads. Hand tighten the ball joint nut onto the tapered pin to align and seat it properly. [Torque to 70 ft-lbs]

10. Reinstall the outer tie rod end. [Torque to factory spec]

11. Repeat steps on passenger side.

12. Install wheels and lower vehicle to the ground. [Torque lugs to factory spec]

13. ICON billet upper control arms utilize heim joints at each pivot to allow alignment using the adjusters on the upper control arms as well as cam adjusters on the lower control arms. The heims can be extended or contracted by turning the adjustment collar. Make sure that the slit in the collar lines up with the slit in the housing and then tighten the pinch bolts evenly in an opposing pattern at least 3 times. Do not exceed 1.875" of adjustment from the center of the rod end to the edge of the billet UCA. [Torque to 40 ft-lbs]

14. Have the vehicle professionally aligned.

15. Once aligned, apply BLUE thread locker to the outer pinch bolts located on the sides of the arm. Tighten the pinch bolts in an opposing pattern at least 3 times. [Torque to 40 ft-lbs]

VERIFY ALL FASTENERS ARE PROPERLY TORQUED BEFORE DRIVING VEHICLE.

RETORQUE ALL NUTS, BOLTS AND LUGS AFTER 100 MILES AND PERIODICALLY THEREAFTER.



ALIGNMENT NOTE

ICON SHIPS THE BILLET UPPER CONTROL ARM AT THE MOST COMMON ALIGNMENT SETTING. ONE OF THE MAJOR PERFORMANCE ADVANTAGES OF AN ICON BILLET ADJUSTABLE UPPER CONTROL ARM IS THE ABILITY TO IMPROVE WHEEL POSITION. IMPROVING WHEEL POSITION IMPROVES FIREWALL CLEARANCE ALLOWING FOR LARGER TIRES AS THE SUSPENSION CYCLES. IN ORDER TO TAKE ADVANTAGE OF THIS FEATURE, DISCUSS WITH YOUR PROFESSIONAL ALIGNMENT SHOP THAT YOU WOULD LIKE TO CAM THE LOWER CONTROL ARM TO MAXIMIZE WHEEL POSITION FORWARD AND THEN ADJUST CAMBER AND CASTER WITH THE UPPER THREADED ADJUSTERS.

A MAJOR PERFORMANCE ADVANTAGE OF ALL ICON UPPER CONTROL ARMS IS INCREASED CASTER OVER STOCK. DISCUSS WITH A PROFESSIONAL ALIGNMENT SHOP THAT YOU WANT THE VEHICLE ALIGNED WITH THE CASTER AT THE MAX OF THE FACTORY RECOMMENDED SETTINGS IF YOU WANT TO TAKE ADVANTAGE OF THE DYNAMIC EFFECTS OF INCREASED CASTER.

ICON VEHICLE DYNAMICS LIABILITY DISCLAIMER

ICON does not make any representations or warranties regarding the fitness of any ICON product for a particular installation or conformance of any ICON product with a particular vehicle application. Installation of any ICON suspension system is at the sole discretion of the end user and in making a purchase of any ICON suspension system, the purchaser assumes the responsibility and liability for any and all damage or injury, of any kind or nature whatsoever, caused by, resulting from, arising out of, or occurring in connection with the use or installation of any ICON suspension system. ICON is not liable for and specifically disavows any installation that is not in conformance with original equipment manufacturer's recommendations or instructions. Purchaser agrees that in the event of any claim or lawsuit arising out of the installation or use of an ICON suspension system, purchaser shall indemnify and hold harmless ICON, its agents, employees, officers and owners from and against any and all loss, expense, damage or injury that ICON may sustain as the result of such claim. [If applicable, ICON defers to and recommends recalibration of any/all vehicle stability systems after suspension installation.]

ICON VEHICLE DYNAMICS LIMITED LIFETIME WARRANTY

ICON Vehicle Dynamics warrants to the original retail purchaser who owns the vehicle on which the product was originally installed. ICON Vehicle Dynamics does not warrant the product for finish, alterations, modifications and/or installation contrary to ICON Vehicle Dynamics instructions. ICON Vehicle Dynamics products are not designed, nor are they intended to be installed on vehicles used in race applications, for racing purposes or for similar activities. (A "race" is defined as any contest between two or more vehicles, or a contest of one or more vehicles against the clock, whether or not such contest is for a prize). This warranty does not include coverage for police or taxi vehicles, race vehicles, or vehicles used for government or commercial purposes. Also excluded from this warranty are sales outside of the United States of America and Canada.

ICON Vehicle Dynamics' obligation under this warranty is limited to the repair or replacement, at ICON Vehicle Dynamics' discretion, of the defective product. Any and all costs of removal, installation or re-installation, freight charges and incidental or consequential damages are expressly excluded from this warranty. Items that are subject to wear are not considered defective when worn and are not covered.

ICON Vehicle Dynamics components must be installed as a complete kit as shown in our current application guide. Any substitutions or exemptions of required components will immediately void the warranty. Some finish damage may happen to parts during shipping and is not covered under warranty.

This warranty is expressly in lieu of all other warranties expressed or implied. This warranty shall not apply to any product that has been improperly installed, modified or customized subject to accident, negligence, abuse or misuse.



ICON VEHICLE DYNAMICS®
PERFORMANCE SUSPENSION SYSTEMS AND SHOCK ABSORBERS

7929 Lincoln Ave. Riverside, CA 92504 Phone: 951.689.ICON Fax: 951.689.1016
www.iconvehicledynamics.com



FOLLOW US ON FACEBOOK!

