

7929 Lincoln Ave. Riverside, CA 92504
Phone: 951.689.ICON | Fax: 951.689.1016

PART #	DESCRIPTION
62530	2005-UP FSD 2.5 ALIGNMENT CAM KIT

COMPONENTS INCLUDED	
(2) 167008 SD ALIGNMENT CAM 0.5 CAM/2.3 CAS	
HARDWARE INCLUDED	
(2) 605900 1/8 X 2.000 COTTER PIN STEEL	
TOOLS REQUIRED	
PLIERS BRASS HAMMER	TORQUE WRENCH 24MM SOCKET / WRENCH
TECH NOTES	
1. ALIGNMENT CAM INSTALLATION NOT REQUIRED FOR VEHICLES EQUIPED WITH ICON RADIUS ARM SYSTEM (#64041)	

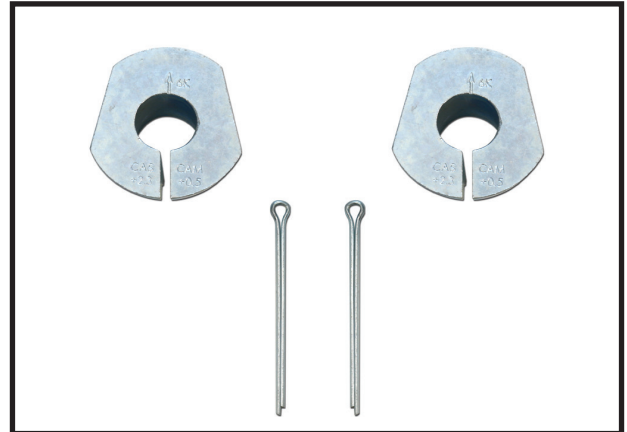

WARNING!
** READ ALL INSTRUCTIONS THOROUGHLY FROM START TO FINISH BEFORE BEGINNING INSTALLATION! IF THESE INSTRUCTIONS ARE NOT PROPERLY FOLLOWED SEVERE FRAME, SUSPENSION AND TIRE DAMAGE MAY RESULT TO THE VEHICLE!
** ICON VEHICLE DYNAMICS RECOMMENDS THAT YOU EXERCISE EXTREME CAUTION WHEN WORKING UNDER A VEHICLE THAT IS SUPPORTED WITH JACK STANDS.
** ICON VEHICLE DYNAMICS RECOMMENDS ALL INSTALLATION TO BE PERFORMED BY A PROFESSIONAL SHOP/SERVICE TECHNICIAN. PRODUCT FAILURE CAUSED BY IMPROPER INSTALLATION WILL NOT BE COVERED UNDER ICON'S WARRANTY POLICY.

INSTALLATION

- Lift the front end of the truck and support the frame at the front frame rails with jack stands. NEVER WORK UNDER AN UNSUPPORTED VEHICLE. Remove front wheels.
- Remove the driver side stock alignment cam: Remove the cotter pin from the ball joint castle nut. Remove the castle nut from the upper ball joint using a 24mm. With a brass hammer, strike the ball joint stud to dislodge the taper. Be careful not to damage the threads. Remove stock alignment cam.
- Install the new alignment cam: Make sure the arrow is pointing toward the front of the truck and the flat end of the cam is aligned with the flat end of the knuckle. Use the old sleeve to tap the new one down onto the taper. Install the castle nut using a 24mm [Torque to 69 ft-lbs]. Install the new cotter pin.
- Repeat the previous steps for the passenger side.
- Reinstall the wheels and lower the vehicle to the ground.
- Have the vehicle professionally aligned: Caster and camber are now set with the alignment cam.

VERIFY ALL FASTENERS ARE PROPERLY TORQUED BEFORE DRIVING VEHICLE.

RETORQUE ALL NUTS, BOLTS AND LUGS AFTER 100 MILES AND PERIODICALLY THEREAFTER.

ICON VEHICLE DYNAMICS LIMITED LIFETIME WARRANTY

ICON Vehicle Dynamics warrants to the original retail purchaser who owns the vehicle on which the product was originally installed. ICON Vehicle Dynamics does not warrant the product for finish, alterations, modifications and/or installation contrary to ICON Vehicle Dynamics instructions. ICON Vehicle Dynamics products are not designed, nor are they intended to be installed on vehicles used in race applications, for racing purposes or for similar activities. (A "race" is defined as any contest between two or more vehicles, or a contest of one or more vehicles against the clock, whether or not such contest is for a prize). This warranty does not include coverage for police or taxi vehicles, race vehicles, or vehicles used for government or commercial purposes. Also excluded from this warranty are sales outside of the United States of America and Canada.

ICON Vehicle Dynamics' obligation under this warranty is limited to the repair or replacement, at ICON Vehicle Dynamics' discretion, of the defective product. Any and all costs of removal, installation or re-installation, freight charges and incidental or consequential damages are expressly excluded from this warranty. Items that are subject to wear are not considered defective when worn and are not covered.

ICON Vehicle Dynamics components must be installed as a complete kit as shown in our current application guide. Any substitutions or exemptions of required components will immediately void the warranty. Some finish damage may happen to parts during shipping and is not covered under warranty.

This warranty is expressly in lieu of all other warranties expressed or implied. This warranty shall not apply to any product that has been improperly installed, modified or customized subject to accident, negligence, abuse or misuse.



ICON VEHICLE DYNAMICS®
PERFORMANCE SUSPENSION SYSTEMS AND SHOCK ABSORBERS

7929 Lincoln Ave. Riverside, CA 92504 Phone: 951.689.ICON Fax: 951.689.1016
www.iconvehicledynamics.com



FOLLOW US ON FACEBOOK!



7929 Lincoln Ave. Riverside, CA 92504
 Phone: 951.689.ICON Fax: 951.689.1016

PART #	DESCRIPTION
64045	2011-UP FSD RADIUS ARM DROP KIT

COMPONENTS INCLUDED	
(1) 164028 11+ FSD RADIUS ARM BRACKET (DRVR) (1) 164029 11+ FSD RADIUS ARM BRACKET (PASS)	(1) 64045H HARDWARE KIT
HARDWARE INCLUDED	
64045H HARDWARE KIT	
(6) 605200 7/16-14 X 1.500 (6) 605220 7/16-14 NYLOCK NUT (12) 605230 7/16 SAE FLAT WASHER	(4) 605601 3/4-10 X 5.500 (4) 605620 3/4-10 NYLOCK NUT (8) 605630 3/4 SAE FLAT WASHER
TOOLS REQUIRED	
JACK JACK STANDS DRILL 7/16" DRILL BIT TORQUE WRENCH 5/8" SOCKET / WRENCH 1 1/8" SOCKET / WRENCH	10MM SOCKET / WRENCH 13MM SOCKET / WRENCH 15MM SOCKET / WRENCH 18MM SOCKET / WRENCH 24MM SOCKET / WRENCH 27MM SOCKET / WRENCH
TECH NOTES	
N/A	



WARNING!

**** READ ALL INSTRUCTIONS THOROUGHLY FROM START TO FINISH BEFORE BEGINNING INSTALLATION! IF THESE INSTRUCTIONS ARE NOT PROPERLY FOLLOWED SEVERE FRAME, SUSPENSION AND TIRE DAMAGE MAY RESULT TO THE VEHICLE!**

**** ICON VEHICLE DYNAMICS RECOMMENDS THAT YOU EXERCISE EXTREME CAUTION WHEN WORKING UNDER A VEHICLE THAT IS SUPPORTED WITH JACK STANDS.**

**** ICON VEHICLE DYNAMICS RECOMMENDS ALL INSTALLTION TO BE PERFORMED BY A PROFESSIONAL SHOP/SERVICE TECHNICIAN. PRODUCT FAILURE CAUSED BY IMPROPER INSTALLATION WILL NOT BE COVERED UNDER ICON'S WARRANTY POLICY.**

INSTALLATION

NOTE: If installing in conjunction with a box kit, skip to step 7.

- Using a properly rated jack, raise the front of the vehicle and support the frame rails with jack stands. Ensure the jack stands are secure and set properly before lowering the jack. NEVER WORK UNDER AN UNSUPPORTED VEHICLE. Remove the front wheels.
- Remove the sway bar links from the sway bar using an 18mm socket/wrench. Leave them connected to the differential. [FIGURE 1]

FIG.1



FIG.2

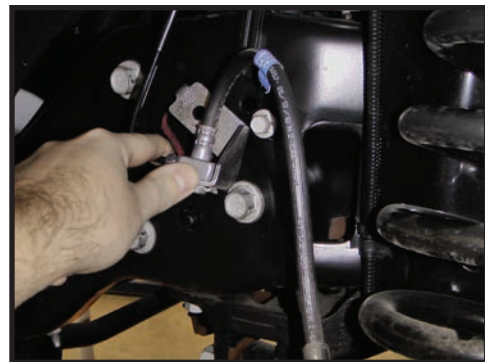

- Disconnect the upper brake line brackets from the frame using a 13mm socket/wrench and lower brake line brackets from the differential using a 10mm socket/wrench. [FIGURE 2]

4. On the driver side of the track bar remove the nut and the upper track bar bolt using two 30mm sockets/wrenches. [FIGURE 3]

FIG.3



5. Support the axle with a floor jack and remove the front shocks. The shocks are limiting droop so make sure the axle is securely supported or it will drop when the shocks are removed. Use an 18mm socket/wrench to remove the lower bolt.

6. As you slowly lower the axle, the coils will unload from the mounts. Be careful not to stretch or damage any lines connected to the differential or radius arms.

7. Some trucks have a transfer case skid plate that must be removed first. Use a 15mm socket/wrench to loosen and then remove the nut clips from the frame.

8. With both coils unloaded, the radius arms have little force on them and can be safely removed from the frame mount. Use a 27mm and a 30mm socket/wrench.

9. Position the driver side radius arm bracket into the stock radius arm pocket. Loosely install the supplied (605601) bolts with (605230) washers into the front frame and radius arm bracket holes. [FIGURE 4]

FIG.4



10. Rotate the bracket up until it meets the frame. Install (605200) bolts with (605230) washers and (605220) nylock nuts through the 2 holes in the bottom of the frame rail. [Torque to 55 ft-lbs]

11. Use the bracket as a guide to center punch and drill 7/16" hole on the side of the frame. Deburr hole and install a (605200) bolt with (605230) washer and (605220) nut. [Torque to 55 ft-lbs]

12. On the passenger side, the hole in the side of the frame is there but the two holes in the bottom of the frame will need to be drilled. Using the bracket as a guide, center punch and drill the holes on the bottom for the frame to 7/16". Install both (605200) bolts [Torque to 55 ft-lbs] [FIGURE 5 & 6]

FIG.5



FIG.6

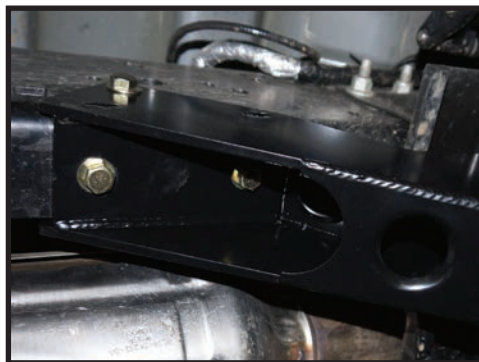

13. Install two (605601) remaining bolts in the remaining frame/bracket hole.

14. You should have both of the frame brackets installed loosely on the vehicle. [Torque 3/4 bolts to 260 ft-lbs] [Torque stock bolts to factory spec]

15. Move the radius arms up into the pockets of the drop bracket and install the factory bolt. Tighten using a 27mm and a 30mm socket/wrench. [Torque to factory spec]

16. Use a jack to raise the axle high enough to install the shocks. Be careful not to lift the truck off of it's supports.
17. Tighten the front shocks using an 18mm socket/wrench. [Torque to factory spec]
18. Install the sway bar to the sway bar links, then tighten using an 18mm socket/wrench. [Torque to factory spec]
19. Connect the track bar using the factory bolt and two 30mm sockets/wrenches. [Torque to factory spec].
20. Install the upper brake line brackets using a 13mm socket/wrench and lower brake line brackets using a 10mm socket/wrench. [Torque to factory spec]
21. Install the front wheels and lower the vehicle back to the ground. [Torque to factory spec]
22. Have the vehicle professionally aligned.

VERIFY ALL FASTENERS ARE PROPERLY TORQUED BEFORE DRIVING VEHICLE.

RETORQUE ALL NUTS, BOLTS AND LUGS AFTER 100 MILES AND PERIODICALLY THEREAFTER.

ICON VEHICLE DYNAMICS LIMITED LIFETIME WARRANTY

ICON Vehicle Dynamics warrants to the original retail purchaser who owns the vehicle on which the product was originally installed. ICON Vehicle Dynamics does not warrant the product for finish, alterations, modifications and/or installation contrary to ICON Vehicle Dynamics instructions. ICON Vehicle Dynamics products are not designed, nor are they intended to be installed on vehicles used in race applications, for racing purposes or for similar activities. (A "race" is defined as any contest between two or more vehicles, or a contest of one or more vehicles against the clock, whether or not such contest is for a prize). This warranty does not include coverage for police or taxi vehicles, race vehicles, or vehicles used for government or commercial purposes. Also excluded from this warranty are sales outside of the United States of America and Canada.

ICON Vehicle Dynamics' obligation under this warranty is limited to the repair or replacement, at ICON Vehicle Dynamics' discretion, of the defective product. Any and all costs of removal, installation or re-installation, freight charges and incidental or consequential damages are expressly excluded from this warranty. Items that are subject to wear are not considered defective when worn and are not covered.

ICON Vehicle Dynamics components must be installed as a complete kit as shown in our current application guide. Any substitutions or exemptions of required components will immediately void the warranty. Some finish damage may happen to parts during shipping and is not covered under warranty.

This warranty is expressly in lieu of all other warranties expressed or implied. This warranty shall not apply to any product that has been improperly installed, modified or customized subject to accident, negligence, abuse or misuse.

ICON VEHICLE DYNAMICS

PERFORMANCE SUSPENSION SYSTEMS AND SHOCK ABSORBERS

7929 Lincoln Ave. Riverside, CA 92504 Phone: 951.689.ICON Fax: 951.689.1016
www.iconvehicledynamics.com



FOLLOW US ON FACEBOOK!



7929 Lincoln Ave. Riverside, CA 92504
Phone: 951.689.ICON | Fax: 951.689.1016

PART #	DESCRIPTION
67030	2011-UP FSD FRONT 7" BOX KIT

COMPONENTS INCLUDED

(2) 164008 05-UP FSD UPPER BRAKE LINE DROP (1) 164027 08-UP FSD TRACK BAR BRACKET (2) 164030 08-UP FSD SWAYBAR DROP BRACKET	(1) 164031 11-UP FSD STEERING STAB. DROP BRACKET (2) 167011 05-UP FSD FRONT BUMPSTOP SPACER (1) 168040 05-UP FSD DROP PITMAN ARM (1) 67020H HARDWARE KIT
-----------------------------------------------------------------------------------------------------------------------------------	-------------------------------------------------------------------------------------------------------------------------------------------------------------------

HARDWARE INCLUDED

67020H HARDWARE KIT

(2) 605011 5/16-18 X .750 BOLT (2) 605012 3/8-16 SPLIT LOCK WASHER (4) 605101 3/8-16 X 1.000 BOLT	(4) 605133 3/8 FLAT WASHER (2) 605804 M8-1.25 X 120MM BOLT (1) 605900 1/8 X 2.000 COTTER PIN
---------------------------------------------------------------------------------------------------------	----------------------------------------------------------------------------------------------------

67031H HARDWARE KIT

(1) 605101 3/8-16 X 1.000 BOLT (1) 605122 3/8-16 C-LOCK NUT (2) 605133 3/8" FLAT WASHER	(1) 605203 7/16-14 X 1.000 BOLT (1) 605220 7/16-14 NYLOCK NUT (2) 605230 7/16" FLAT WASHER
-----------------------------------------------------------------------------------------------	--------------------------------------------------------------------------------------------------

TOOLS REQUIRED

JACK JACK STANDS BRASS HAMMER STEEL HAMMER PLIERS TORQUE WRENCH 3/8" SOCKET / WRENCH 1/2" SOCKET / WRENCH 5/8" SOCKET / WRENCH 3/4" SOCKET / WRENCH	15/16" SOCKET / WRENCH 10MM SOCKET / WRENCH 13MM SOCKET / WRENCH 15MM SOCKET / WRENCH 16MM SOCKET / WRENCH 18MM SOCKET / WRENCH 21MM SOCKET / WRENCH 24MM SOCKET / WRENCH 30MM SOCKET / WRENCH 46MM SOCKET / WRENCH
--------------------------------------------------------------------------------------------------------------------------------------------------------------------------------	------------------------------------------------------------------------------------------------------------------------------------------------------------------------------------------------------------------------------------------------

TECH NOTES

1. REQUIRED KITS: ICON 4-LINK KIT PN: (61550 2011-16)
OR
RADIUS ARM DROP KIT PN: (64045 2011-16) AND CASTER CAM KIT PN: (63530)

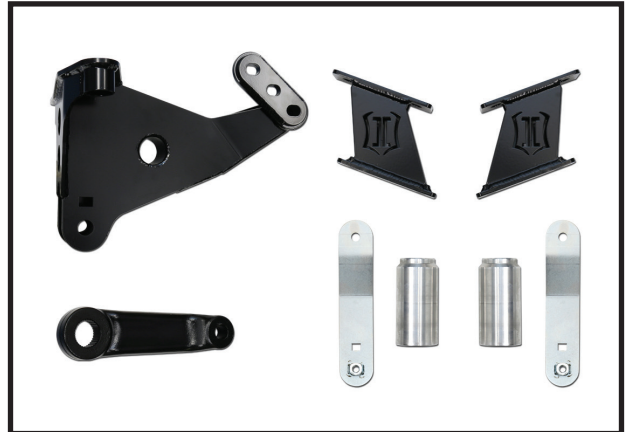

WARNING!

**** READ ALL INSTRUCTIONS THOROUGHLY FROM START TO FINISH BEFORE BEGINNING INSTALLATION! IF THESE INSTRUCTIONS ARE NOT PROPERLY FOLLOWED SEVERE FRAME, SUSPENSION AND TIRE DAMAGE MAY RESULT TO THE VEHICLE!**

**** ICON VEHICLE DYNAMICS RECOMMENDS THAT YOU EXERCISE EXTREME CAUTION WHEN WORKING UNDER A VEHICLE THAT IS SUPPORTED WITH JACK STANDS.**

**** ICON VEHICLE DYNAMICS RECOMMENDS ALL INSTALLATION TO BE PERFORMED BY A PROFESSIONAL SHOP/SERVICE TECHNICIAN. PRODUCT FAILURE CAUSED BY IMPROPER INSTALLATION WILL NOT BE COVERED UNDER ICON'S WARRANTY POLICY.**

INSTALLATION

- Using a properly rated jack, raise the front of the vehicle and support the frame rails with jack stands. Ensure the jack stands are secure and set properly before lowering the jack. NEVER WORK UNDER AN UNSUPPORTED VEHICLE. Remove front wheels.
- Remove the sway bar links from the sway bar using an 18mm socket/wrench. Leave them connected to the differential. [FIGURE 1]

FIG.1

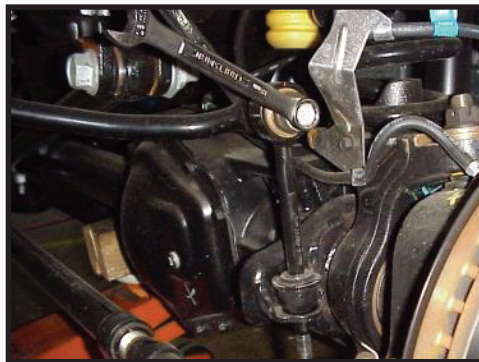
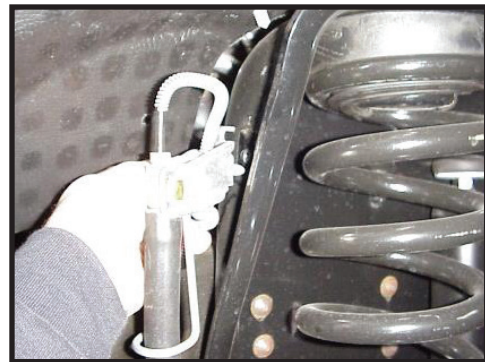

FIG.2



- Disconnect the upper brake line brackets from the frame using a 13mm socket/wrench and lower brake line brackets from the differential using a 10mm socket/wrench. [FIGURE 2]

- 4.** On the driver side of the track bar, remove the nut and the upper track bar bolt using (2) 30mm socket/wrenches. **[FIGURE 3]**

FIG.3

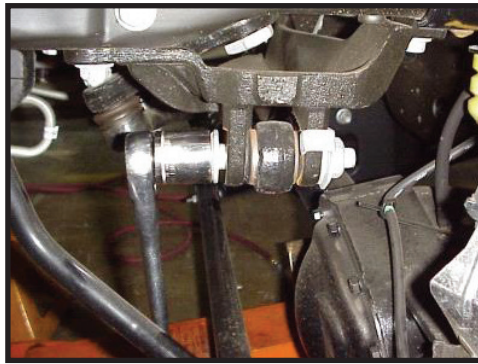

- 5.** Support the axle with a floor jack and remove the front shocks. The shocks are limiting droop so make sure that the axle is supported or it will fall when the shocks are removed. (21mm socket/wrench, 18mm socket/wrench)
- 6.** Slowly lower the axle, the coils will unload from the mounts and can be removed. Be careful not to stretch or damage any lines connected to the axle or radius arms.
- 7.** Remove the stock track bar bracket: Remove the (2) bolts going up into the frame using an 18mm and the (3) nuts on the crossmember using a 21mm. Remove the stud plate from the crossmember and fully remove the track bar bracket.
- 8.** Refer to 4-Link instructions (61500 <2005-2010>) or (61550 <2011-2016>) and or radius arm kit (64040 <2005-2010>) or (64045 <2011-2016>) and install now.
- 9.** If using radius arm kit, caster cams are required. Refer to caster cam instructions (63530) and install now.
- 10.** If the coilover conversion (61950) has been purchased, refer to the coilover instructions and install now.
- 11.** Lower the axle just enough to install the new springs. Place the original rubber isolator on top of the new coil and install. Be careful to not stretch or damage any lines. Check the rotation/clocking of the coil to make sure it is properly seated in the lower spring perch.
- 12.** Lift the axle high enough to connect the shocks but be careful not to lift the truck off of its supports. Use the original bolt on the lower shock mount and tighten with an 18mm socket/wrench [Torque to factory spec]. Tighten the stem top nut using a 3/4" socket/wrench. (Refer to shock Instructions)
- 13.** Slowly lower the axle after the shocks are installed.
- 14.** Refer to pitman arm instructions (191002) and replace pitman arm now.
- 15.** Install the new track bar bracket using stock hardware. Hold the track bar bracket in position and insert the stud plate through the crossmember and bracket. Use a small amount of thread locker on threads, and install nuts using a 21mm. Use thread lock on frame bolts and install using an 18mm. [Torque to factory spec] **[FIGURE 4]**

FIG.4

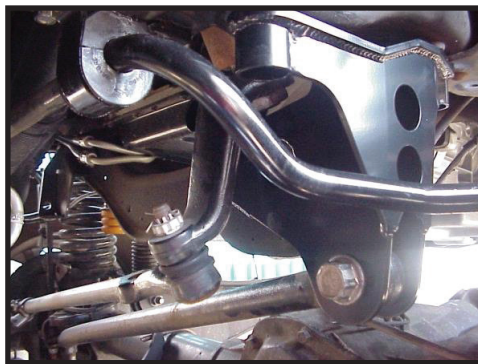

- 16.** If an ICON adjustable track bar (64031) was purchased, refer to track bar installation instructions now.
- 17.** Remove the steering stabilizer from the factory frame bracket using a 15mm. Remove the bracket from the frame using an 18mm. Remove the steering stabilizer from the drag link using an 18mm, then use a ball joint separator or a hammer to break the taper loose and remove the stabilizer.
- 18.** Mount the stabilizer drop bracket to the frame and tighten using factory hardware and an 18mm [Torque to factory spec]. Connect the steering stabilizer to the new bracket using factory hardware [Torque to factory spec].
- 19.** Reconnect the track bar to the frame bracket using the factory hardware and (2) 30mm. You may have to raise or lower the axle to help line up the holes. [Torque to factory spec]

20. Pry the front bump stops out of the bump stop cup. Remove the bolt in the center of the cup using a 10mm. Install the bump stop spacer between the cup and the frame with the supplied bolt. The cup has a flat side on its outer flange. Rotate the flat side to be near the coil for added clearance. [Torque to factory spec] [FIGURE 5]

FIG.5



21. Push the bump stops back into the cups until they clip/snap into place.

22. Remove the sway bar from the frame using a 13mm.

23. Install sway bar drop brackets (164030) using the factory hardware and a 13mm. [Torque to factory spec] [FIGURE 6]

FIG.6



24. Using 3/8" hardware and a 9/16" socket/wrench, install the sway bar to the new drop brackets. [Torque to 33 ft-lbs]

25. Reconnect the sway bar to the stock links using an 18mm. [Torque to factory spec]

26. Install the upper brake line brackets using the factory bolts. This bracket uses the factory bolt on the top and a supplied 5/16" bolt on the bottom. Using (2) 1/2" wrenches to tighten. [Torque to 19 ft-lbs] Carefully bend and re-route the hard line. [FIGURE 7]

FIG.7

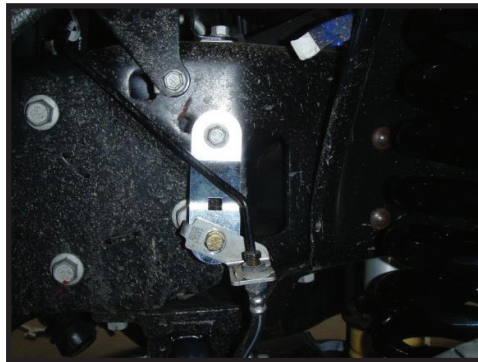

27. Remove parking brake bracket from the side of the frame using a 13mm socket/wrench. Mount the drop bracket using the factory hardware. Fasten the wire bracket to the drop bracket using the supplied 3/8" hardware and a 9/16" socket/wrench. [FIGURE 8 & 9]

FIG.8



FIG.9

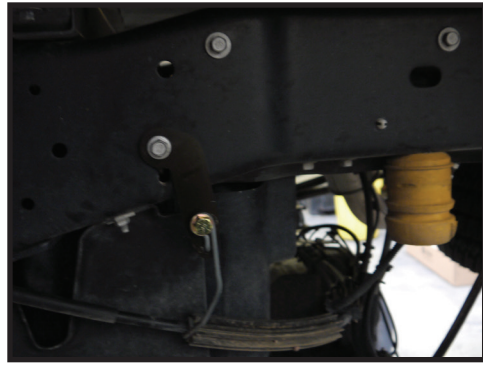

28. Using a 16mm wrench, unscrew the vent hose fitting from the axle tube. Fasten the bracket to the axle tube using the vent hose fitting (tighten 1/8 turn past snug). Fasten the brake lines to the bracket using the supplied 7/16" hardware. [FIGURE 10 & 11]

FIG.10



FIG.11

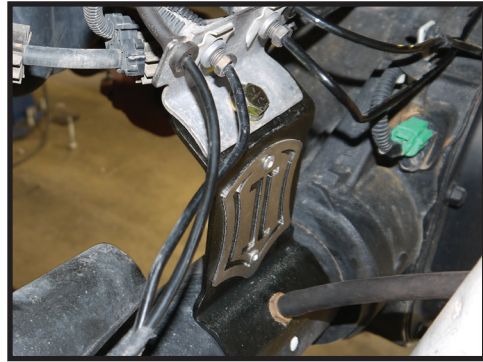

29. If an ICON dual steering stabilizer kit (PN: 65000) has been purchased, refer to steering stabilizer instructions and install now.

30. Reinstall wheels and lower the vehicle to the ground. [Torque to factory spec]

31. Have the vehicle professionally aligned.

VERIFY ALL FASTENERS ARE PROPERLY TORQUED BEFORE DRIVING VEHICLE.

RETORQUE ALL NUTS, BOLTS AND LUGS AFTER 100 MILES AND PERIODICALLY THEREAFTER.

ICON VEHICLE DYNAMICS LIMITED LIFETIME WARRANTY

ICON Vehicle Dynamics warrants to the original retail purchaser who owns the vehicle on which the product was originally installed. ICON Vehicle Dynamics does not warrant the product for finish, alterations, modifications and/or installation contrary to ICON Vehicle Dynamics instructions. ICON Vehicle Dynamics products are not designed, nor are they intended to be installed on vehicles used in race applications, for racing purposes or for similar activities. (A "race" is defined as any contest between two or more vehicles, or a contest of one or more vehicles against the clock, whether or not such contest is for a prize). This warranty does not include coverage for police or taxi vehicles, race vehicles, or vehicles used for government or commercial purposes. Also excluded from this warranty are sales outside of the United States of America and Canada.

ICON Vehicle Dynamics' obligation under this warranty is limited to the repair or replacement, at ICON Vehicle Dynamics' discretion, of the defective product. Any and all costs of removal, installation or re-installation, freight charges and incidental or consequential damages are expressly excluded from this warranty. Items that are subject to wear are not considered defective when worn and are not covered.

ICON Vehicle Dynamics components must be installed as a complete kit as shown in our current application guide. Any substitutions or exemptions of required components will immediately void the warranty. Some finish damage may happen to parts during shipping and is not covered under warranty.

This warranty is expressly in lieu of all other warranties expressed or implied. This warranty shall not apply to any product that has been improperly installed, modified or customized subject to accident, negligence, abuse or misuse.



ICON VEHICLE DYNAMICS®
PERFORMANCE SUSPENSION SYSTEMS AND SHOCK ABSORBERS

7929 Lincoln Ave. Riverside, CA 92504 Phone: 951.689.ICON Fax: 951.689.1016
www.iconvehicledynamics.com



FOLLOW US ON FACEBOOK!

