

MOMENTUM HD

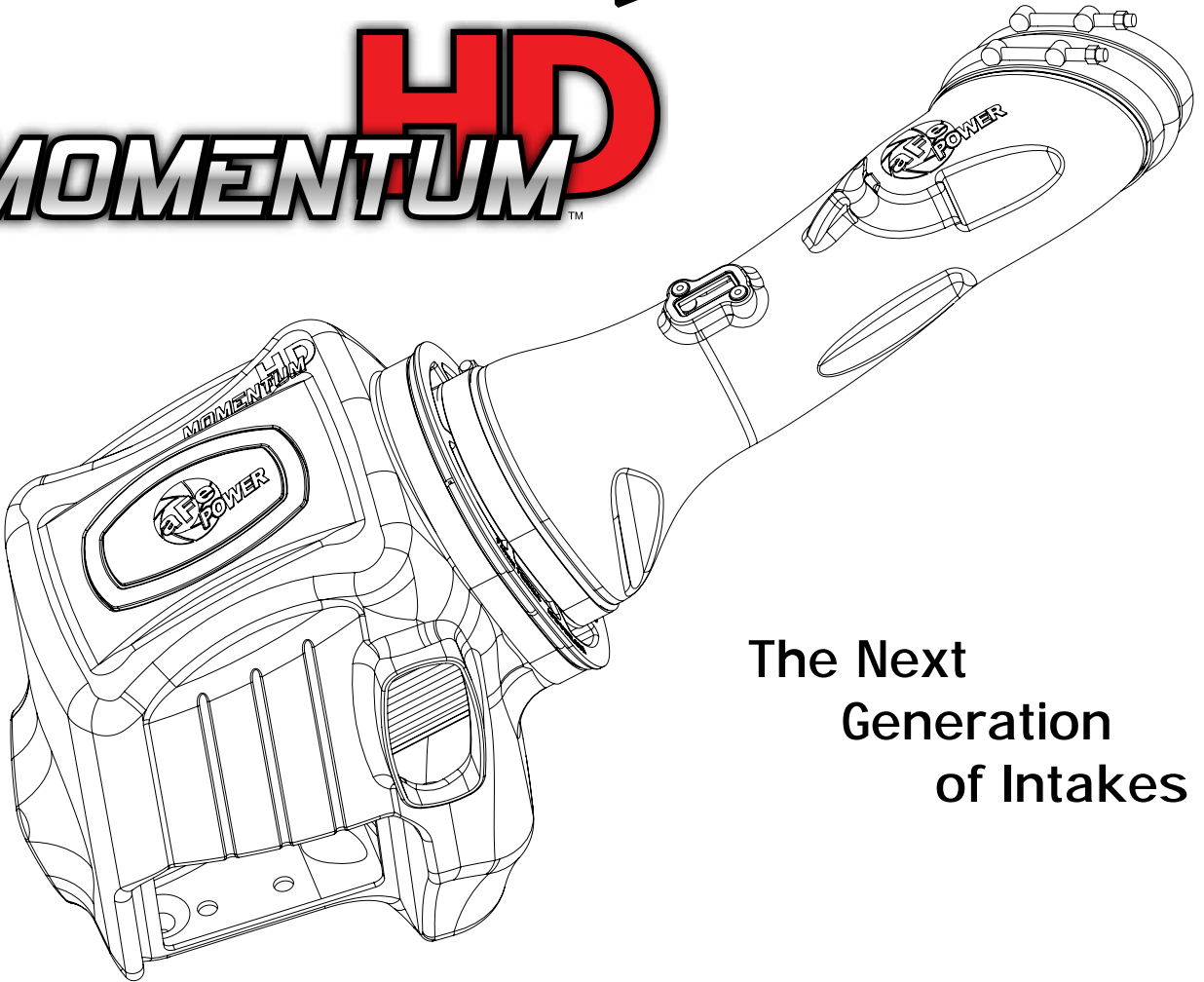

The Next
Generation
of Intakes

advanced FLOW engineering Momentum Air Intake System

Instruction Manual P/N: 51-73005-E

Make: Ford Model: F-250/F-350/F-450/F-550 Year: 2011-2016 Engine: V8-6.7L (td)



- Please read the entire instruction manual before proceeding.
- Ensure all components listed are present.
- If you are missing any of the components, call technical support at 951-493-7100 or e-mail tech@afepower.com.
- Ensure you have all necessary tools before proceeding.
- Do not attempt to work on your vehicle when the engine is hot.
- Disconnect the negative battery terminal before proceeding.
- Retain factory parts for future use.

Label	Qty.	Description	Part Number
A	1	Housing	05-73005B2-A
B	1	Plug, Urethane	05-01202
C	1	Clamp, T-bolt (8-5/16")	03-50267
D	1	Air Filter Pro DRY S	21-91061
E	2	Screw, M4	03-50034
F	1	Tube	05-73005B1
G	2	Clamp, T-bolt (4-3/4"-5")	03-50261
H	1	Coupling, Silicone Hump	05-01204
I	1	Fixing Clamp	03-50234
J	1	Flat Washer	03-50070
K	1	Hex Screw	03-50057
L	1	T20 Torx Bit	03-50066
M	1	12oz. Cleaner Spray	90-10011

Installation will require the following tools:
8mm Nut driver, 10mm Nut driver and Torx (T-20) driver.

Warranty Information available at: <https://afepower.com/contact#warranty>

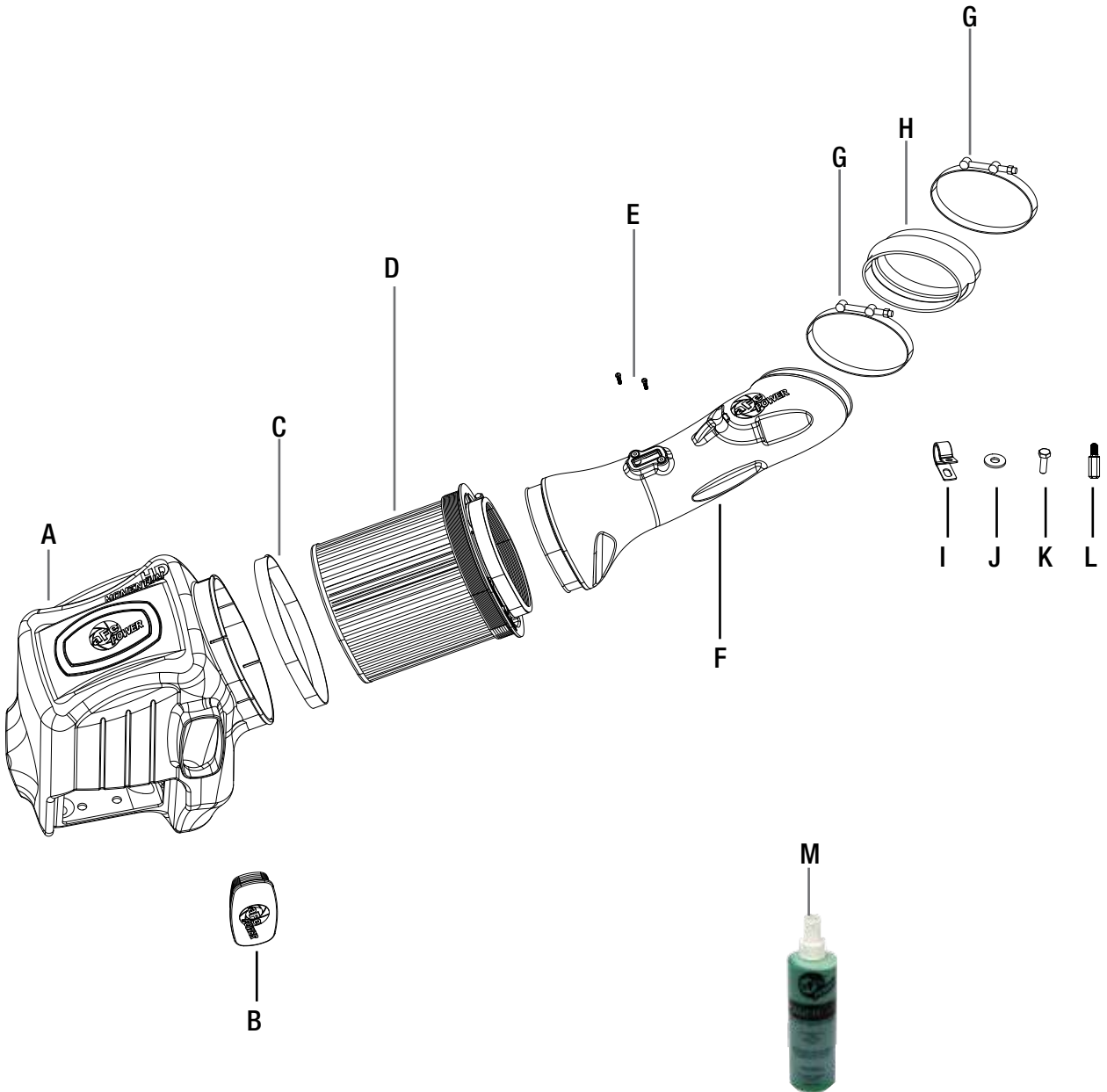



Refer to Figure A for step 1

Step 1: Take off the (2) 8mm screws securing the OE intake tube and filter box and loosen the band clamps.



Figure B

Refer to Figure B for steps 2-3

Step 2: Disconnect the wire harness clip from the filter housing and pull the red tab out on the flow sensor connector, then press the tab and pull off the sensor plug. Remove the flow sensor off the tube with the provided T-20 torx bit.

Step 3: Pull out the air box in an upward motion.



Figure C

Refer to Figure C for step 4

Step 4: Slip all the hoses out of the way on the OE intake tube, loosen the clamps and remove the tube.



Refer to Figure D for steps 5-6

Step 5: Take off the factory mounting grommet from the factory airbox and install it on Momentum HD airbox.

Step 6: Slide filter into housing and install furnished T-bolt clamps. Tighten only the larger T-bolt clamp.



Figure E

Refer to Figure E for step 7

Step 7: Remove rubber inlet gasket from the factory airbox and install it on the momentum HD airbox.



Figure F

Refer to Figure F for step 8

Step 8: Install the Momentum HD housing assembly into the truck by pushing in it into the factory grommet.



Figure G

Refer to Figure G for steps 9-11

- Step 9: Remove the filter minder and grommet ① from the factory airbox and install them on the Momentum HD tube.
- Step 10: Install the Mass Air Flow sensor ② removed at step 2 on the Momentum HD tube using furnished small hex screws.
- Step 11: Slide the silicone coupling ④ and T-bolt clamps ③ onto the small end of the tube. Do to tighten clamps as this time.



Refer to Figure H for steps 12-14

Step 12: Install Momentum HD tube by first sliding the coupling over the turbo inlet. Connect the other end to the air filter.

Step 13: Tighten all clamps.

Step 14: Snap the AC line into tube and secure factory hose with the fixing clamp (I), M6 screw (K) and washer (J).



Refer to Figure I for steps 15-17

Step 15: Re-install factory screw removed in step 1 next to battery (3) to secure Momentum HD airbox.
Step 16: Re-connect the MAF sensor (4). Route the wire harness as shown and secure it to vehicle (5).
Step 17: Tighten all clamps and re-attach negative battery terminal. Your installation is now completed.

Use the furnished plug B to close off the front auxiliary air inlet to completely seal the air box.
NOTE: Retighten all connections after approximately 100-200 miles. Place enclosed CARB EO sticker on or near the device on a smooth/clean surface. EO identification label is required to pass the smog test inspection.

Page left blank intentionally



Page left blank intentionally

Page left blank intentionally

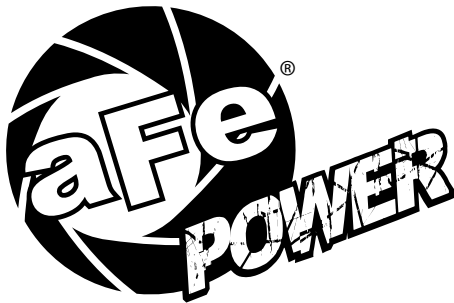

advanced FLOW engineering, inc.
252 Granite Street Corona, CA 92879
TEL: 951.493.7100 • TECH: 951.493.7134
E-Mail: Tech@aFepower.com