

PARTS LIST:

1	Driver/Left NB1 Running Board	8	10mm Nylon Lock Nuts
1	Passenger/Right NB1 Running Board	8	8-1.25mm x 25mm Hex Bolts
2	Driver/Left Mounting Brackets	4	8mm Lock Washers
2	Passenger/Right Mounting Brackets	12	8mm x 24mm OD x 2mm Flat Washers
8	10-1.5mm x 35mm Hex Bolts	4	8mm Nylon Lock Nuts
16	10mm x 27mm OD x 3mm Flat Washers	4	8mm Clip Nuts

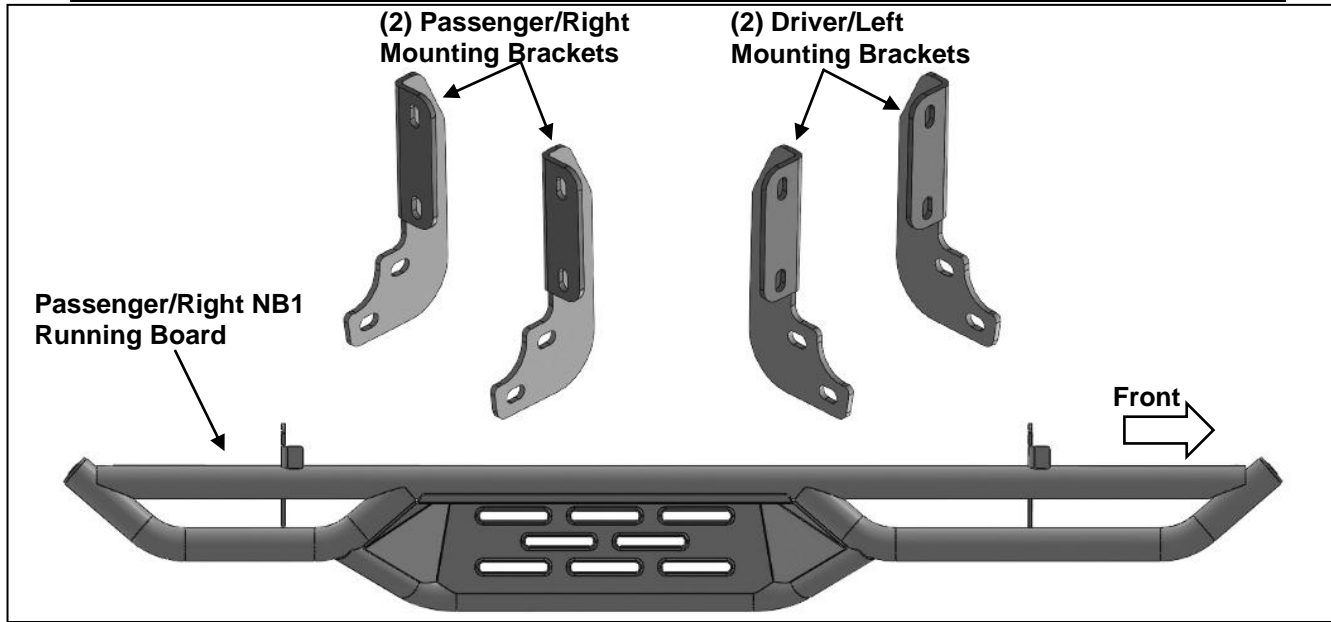

PROCEDURE:

- REMOVE CONTENTS FROM BOX. VERIFY ALL PARTS ARE PRESENT. READ INSTRUCTIONS CAREFULLY BEFORE STARTING INSTALLATION.**
- Starting on the Passenger/Right front of the vehicle, locate the (2) holes through the bottom of the body panel, (pinch weld). Next locate the rectangular opening and (2) small holes in the inner body panel directly above the holes in the pinch weld, **(Figures 1A & 1B)**. **NOTE:** The holes in the inner panel may be covered with sealing tape or insulation, remove as required.
- Slide (1) 8mm Clip Nut into the rectangular opening with the nut towards the inside. Line up the threaded nut on the clip with the round hole toward the rear, **(Figure 2)**.
- Select (1) Passenger/Right Mounting Bracket. Attach the top of the Bracket to the Clip Nut with (1) 8mm Hex Bolt, (1) 8mm Lock Washer and (1) 8mm Flat Washer, **(Figure 3)**. Do not tighten hardware.
- Line up the lower hole in the Bracket with the hole through the pinch weld. Attach the Bracket to the pinch weld with (1) 8mm Hex Bolt, (2) 8mm Flat Washers and (1) 8mm Nylon Lock Nut, **(Figure 3)**. Do not tighten hardware.
- Move to the rear location. Locate the last pair of holes along the pinch weld, **(Figures 1A & 1B)**. Repeat **Steps 2—5** to attach the remaining (1) Passenger/Right Mounting Bracket to the rear location. Do not tighten hardware.
- Select the Passenger/Right NB1 Running Board. Attach the Running Board to the front faces of the Mounting Brackets with (4) 10mm Hex Bolts, (8) 10mm Flat Washers and (4) 10mm Nylon Lock Nuts, **(Figure 4)**. Do not tighten hardware.
- Level and adjust the NB1 Running Board as necessary and fully tighten all hardware.
- Repeat **Steps 2—8** to attach the Driver/Left NB1 Running Board.
- Do periodic inspections to the installation to make sure that all hardware is secure and tight.

To protect your investment, Do not use any type of polish or wax that may contain abrasives that could damage the finish. Mild soap may be used to clean the Running Board.

Passenger/Right Side Installation Pictured

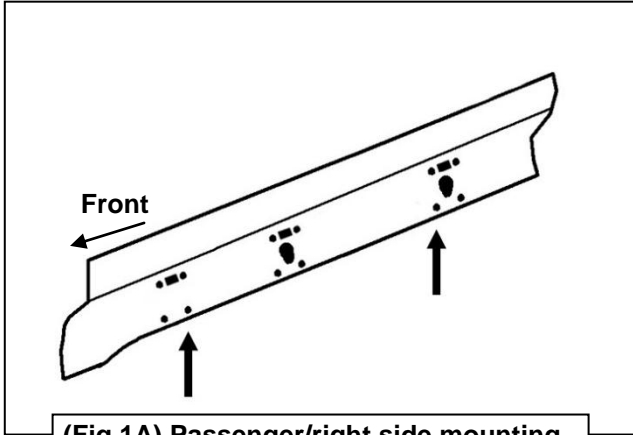

(Fig 1A) Passenger/right side mounting area illustrated for instruction purposes

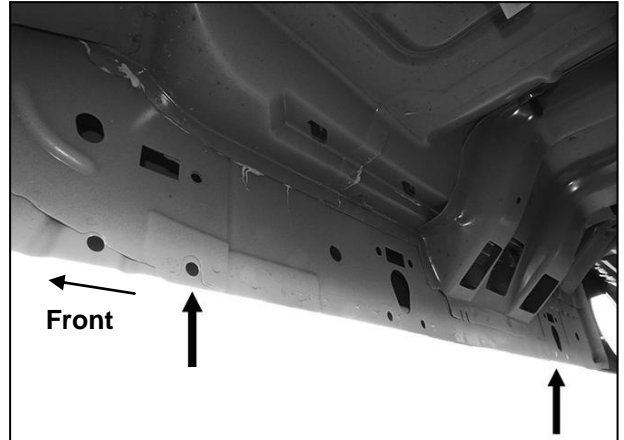

(Fig 1B) Passenger/right side mounting location

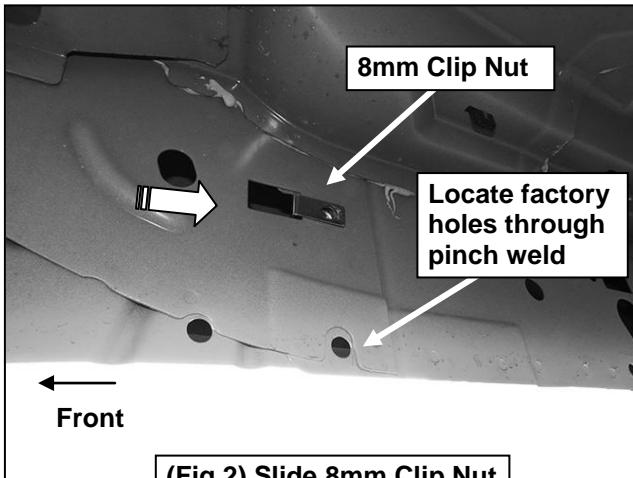

(Fig 2) Slide 8mm Clip Nut into rectangular opening

- 8mm Hex Bolt
- 8mm Lock Washer
- 8mm Flat Washer
- 8mm Clip Nut
- 8mm Hex Bolt
- (2) 8mm Flat Washers
- 8mm Nylon Lock Nut

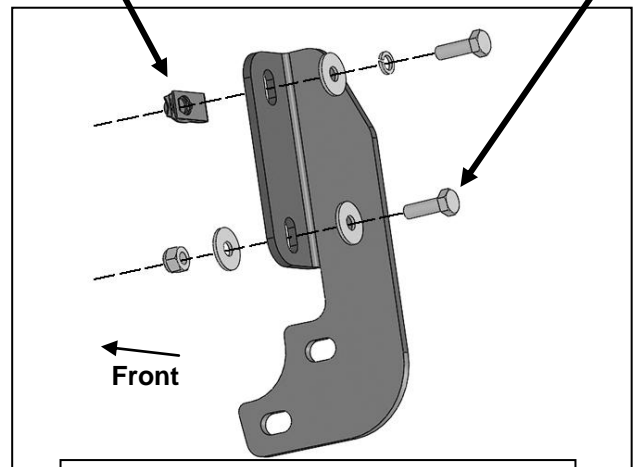

(Fig 3) Attach (1) Passenger/Right Mounting Bracket to the front location

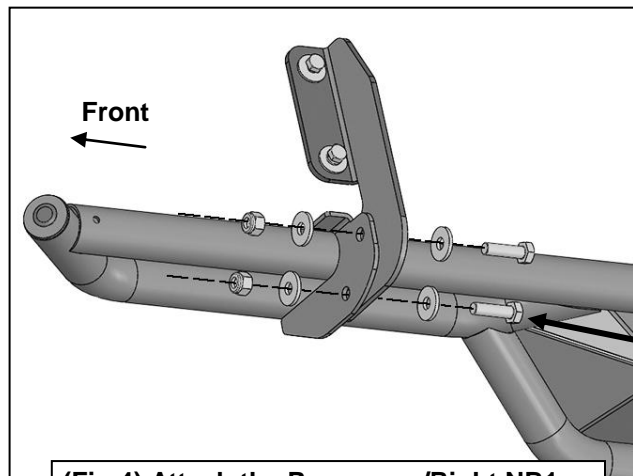

(Fig 4) Attach the Passenger/Right NB1 Running Board to the Mounting Brackets

- (2) 10mm Hex Bolts
- (4) 10mm Flat Washers
- (2) 10mm Nylon Lock Nuts