

PARTS LIST:

2	Aggressive Running Boards	18	8mm Lock Washers
6	Universal Mounting Brackets (left of right)	12	8-1.25mm Hex Nuts
6	8-1.25mm Clip-Nuts	6	8-1.25mm Nylon Lock Nuts
12	8-1.25mm x 25mm Hex Bolts	6	8mm Double Bolt Plates
30	8mm x 24mm x 2mm Flat Washer		

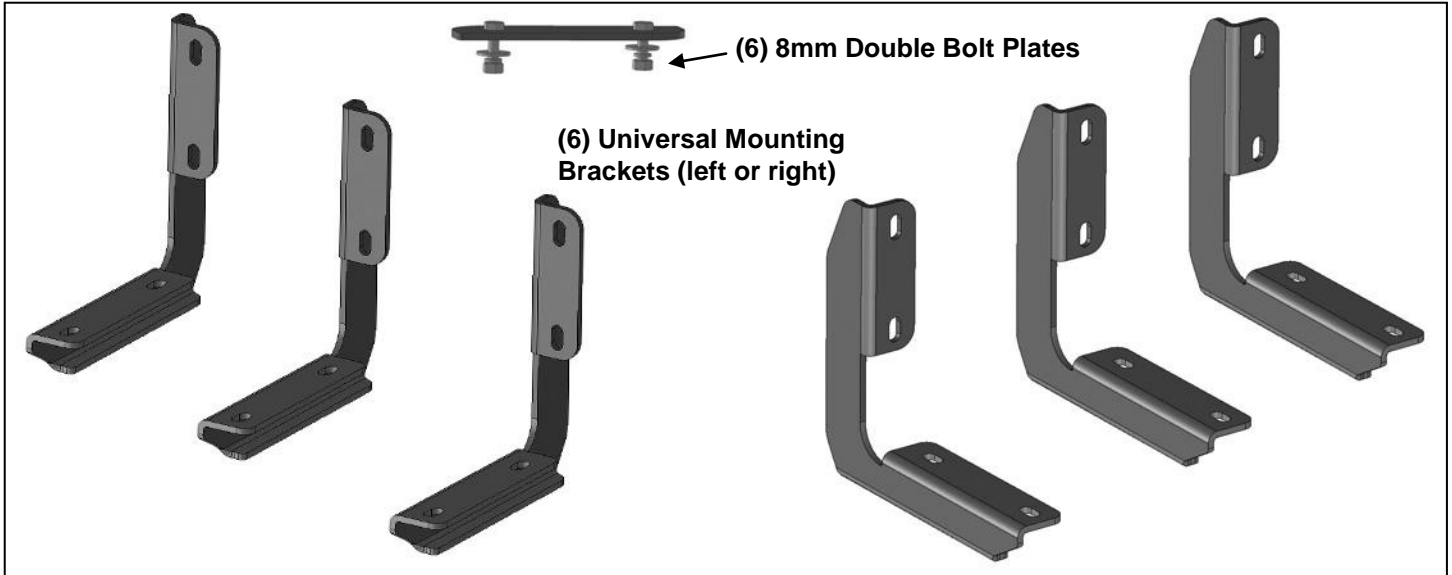

PROCEDURE:

- 1. REMOVE CONTENTS FROM BOX. VERIFY ALL PARTS ARE PRESENT. READ INSTRUCTIONS CAREFULLY BEFORE STARTING INSTALLATION.**
- Starting on the front-driver side of the vehicle, locate the (2) holes through the bottom of the body panel, (pinch weld). Next locate the rectangular opening and small hole in the inner body panel directly above the holes in the pinch weld, **(Figures 1 & 2)**. **NOTE:** The holes in the inner panel may be covered with sealing tape or insulation, remove as required.
- Slide (1) 8mm Clip Nut into the rectangular opening with the nut towards the inside. Line up the threaded nut on the clip with the round hole toward the rear, **(Figure 2)**.
- Select (1) Mounting Bracket. Attach the top of the Bracket to the Clip Nut with (1) 8mm Hex Bolt, (1) 8mm Lock Washer and (1) 8mm Flat Washer, **(Figure 3)**. Leave loose at this time. Line up the lower hole in the Bracket with the hole through the pinch weld. Attach the Bracket to the pinch weld with (1) 8mm Hex Bolt, (2) 8mm Flat Washers and (1) 8mm Nylon Lock Nut, **(Figure 3)**. Snug but do not fully tighten Bracket hardware.
- Move toward the center of the vehicle. Use **Figure 1** to determine the correct mounting location for the center Bracket. Select (1) 8mm Clip Nut. Repeat **Steps 2 & 3** to install (1) Clip Nut in the correct top mounting hole, **(Figure 4)**. Repeat **Step 4** to attach the Bracket to the Clip Nut and pinch weld, **(Figure 5)**. Snug but do not fully tighten Bracket hardware.
- Continue along the cab to the rear mounting location. Locate the last (2) mounting holes in the pinch weld towards the back of the cab, **(Figures 1 & 6)**. Use **Figure 1** to determine correct mounting location. Repeat **Step 5** to install (1) Bracket in the rear location, **(Figures 6 & 7)**.
- Carefully unwrap (1) Running Board. Place the Running Board on top of the Brackets. Locate the channels in the bottom of the Running Board. Select (3) 8mm Double Bolt Plates, **(Figure 8)**. Insert the Bolt Plates into the channels in the bottom of the Running Board closest to the Brackets, **(Figure 9)**. Lift the Running Board up and guide the studs down through the Brackets.

8. Attach the Running Board to the (3) Mounting Brackets with the included (6) 8mm Flat Washers, (6) 8mm Lock Washers and (6) 8mm Hex Nuts, **(Figures 10 & 11)**. Do not tighten hardware at this time.
9. Level and adjust the Running Board front to rear as desired. Note typical installation is with front of Running Board 2" back from front wheel opening or mud flap if equipped. Once adjusted, fully tighten all hardware.
10. Repeat **Steps 1—9** for the passenger side Running Board installation.
11. Do periodic inspections to the installation to make sure that all hardware is secure and tight.

To protect your investment, wax this product after installing. Regular waxing is recommended to add a protective layer over the finish. Do not use any type of polish or wax that may contain abrasives that could damage the finish.

For stainless steel: Aluminum polish may be used to polish small scratches and scuffs on the finish. Mild soap may be used also to clean the Running Board.

For gloss black finishes: Mild soap may be used to clean the Running Board.

Driver Side Installation Pictured

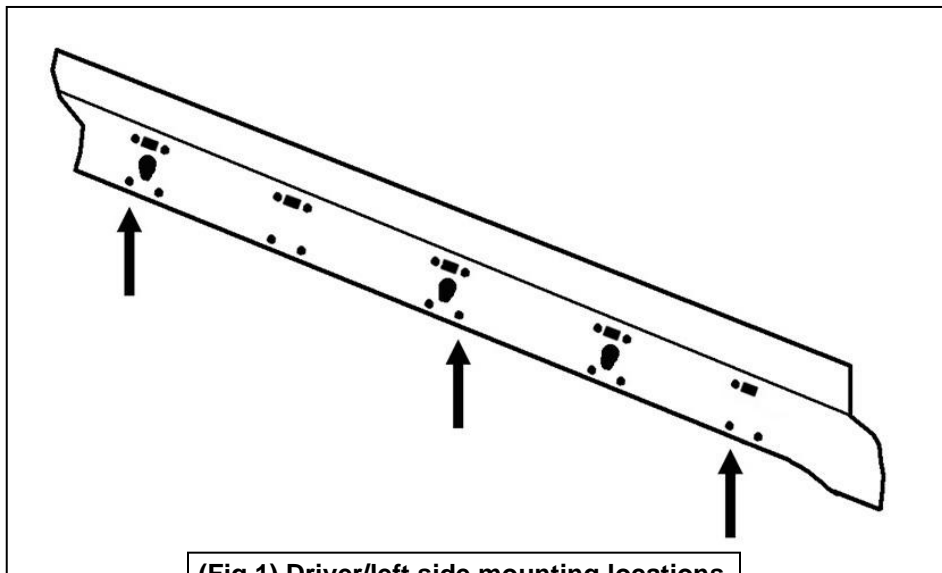

(Fig 1) Driver/left side mounting locations

Locate factory holes through pinch weld

Slide 8mm Clip Nut into rectangular opening

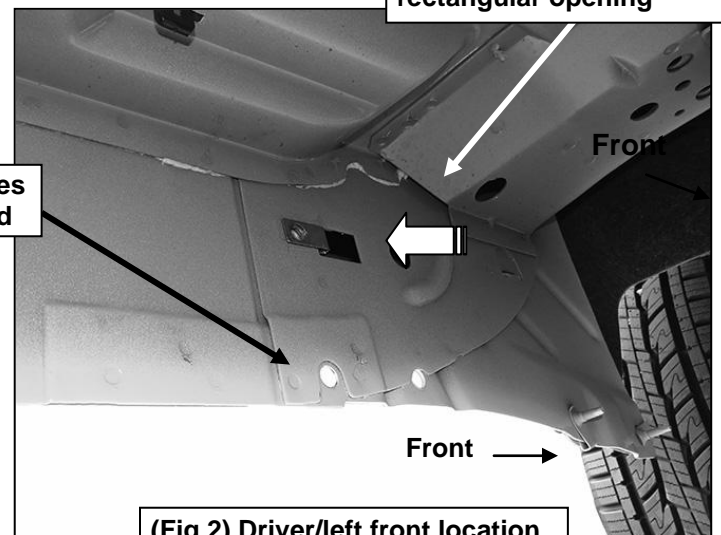

(Fig 2) Driver/left front location

Driver Side Installation Pictured

8mm x 25mm Hex Bolt
(2) 8mm Flat Washers
8mm Nylon Lock Nut

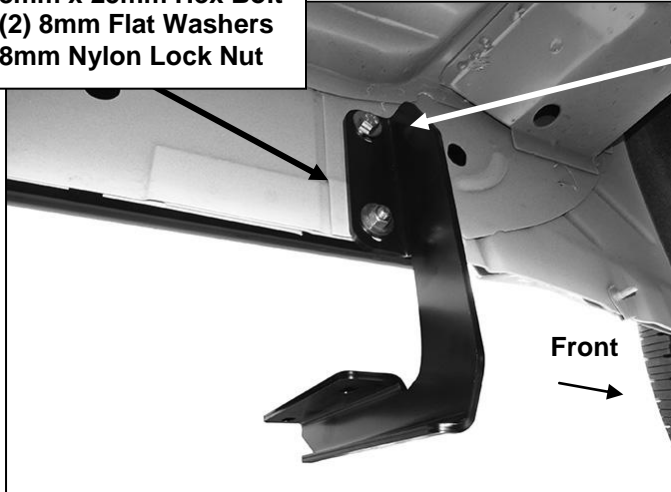

(Fig 3) Driver/left front mounting Bracket pictured

8mm x 25mm Hex Bolt
8mm Lock Washer
8mm Flat Washer

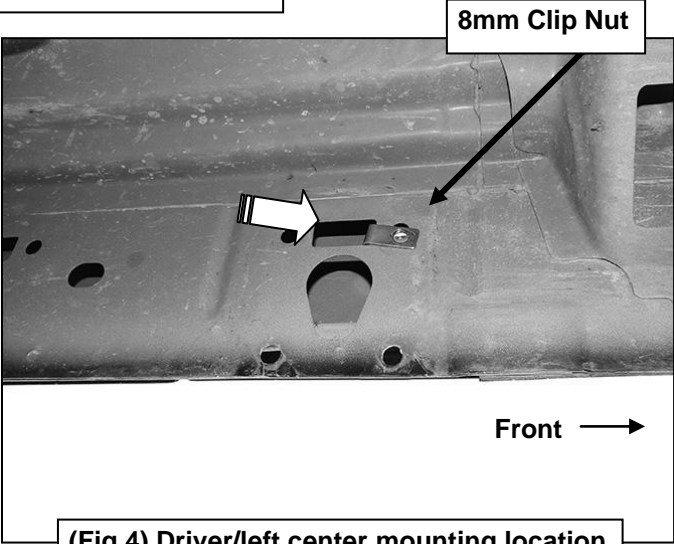

(Fig 4) Driver/left center mounting location

8mm x 25mm Hex Bolt
8mm Lock Washer
8mm Flat Washer

8mm x 25mm Hex Bolt
(2) 8mm Flat Washers
8mm Nylon Lock Nut

8mm Clip Nut

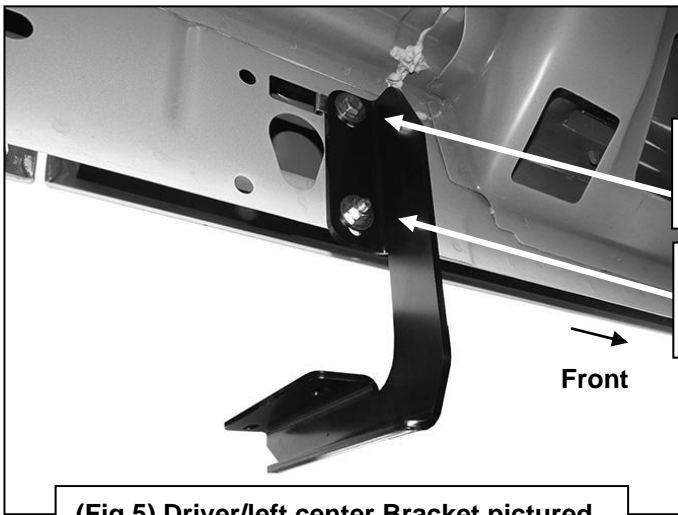

(Fig 5) Driver/left center Bracket pictured

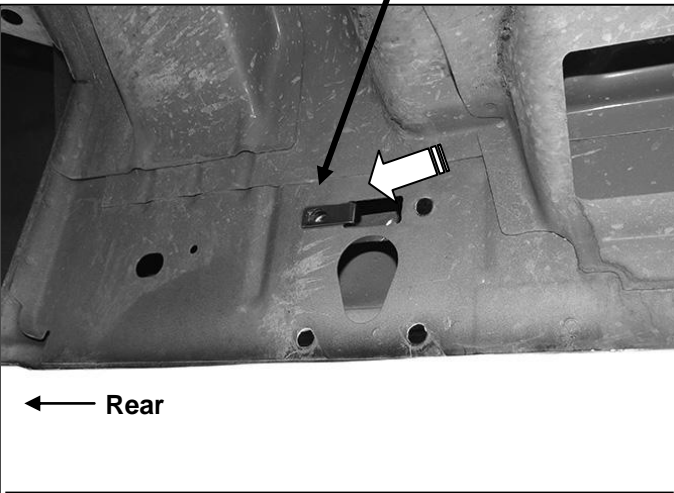

(Fig 6) Driver/left rear Mounting Bracket location



(Fig 7) Driver/left rear Mounting Bracket installed

Driver Side Installation Pictured



(Fig 8) 8mm Double Bolt Plate

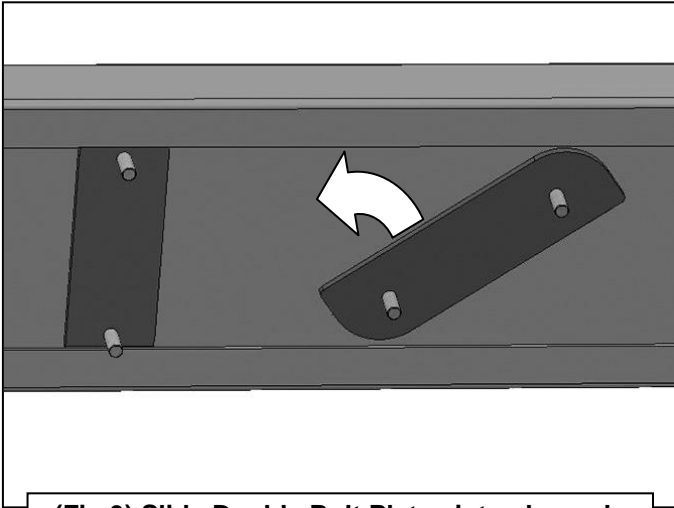

(Fig 9) Slide Double Bolt Plates into channels



(Fig 10) Driver/left front mounting Bracket installed

8mm Double Bolt Plate
(2) 8mm Flat Washers
(2) 8mm Lock Washers
(2) 8mm Hex Nuts

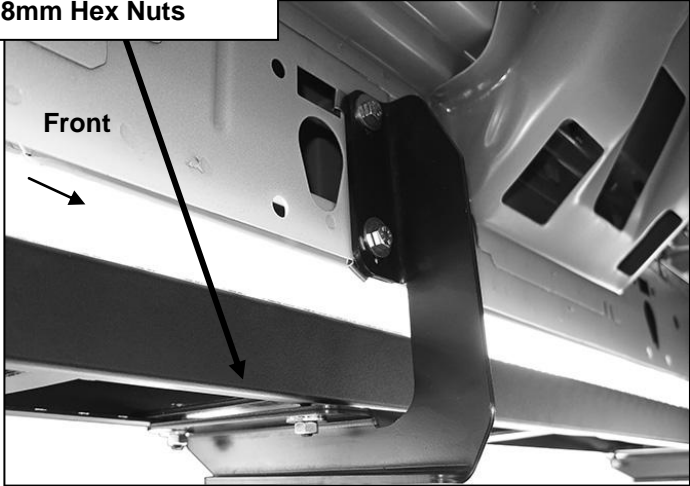

(Fig 11) Driver/left center Mounting Bracket installed



Complete Installation