



**P/N: F351-SS & F352-SS**

***INSTRUCTIONS PACKET***

2017 - 2025 FORD F250 - F350  
WITH 6.2L, 6.8L, 7.3L ENGINE Max:  
176 - Inch Maximum Wheelbase

**F3-12-SS**



2017-2025 FORD F250-F350

Max: 176 - Inch Maximum

Wheelbase

1. Remove the factory system by Unbolting the Joint in front the 2-1 resonator. Unbolting of hanger mount is required for factory removal.
2. Anti-Seize surfaces of Ball with Flange, use the new bolts provided for re-installation. Leave Bottom Clamp in place for PC-22. Leave snug till step 5.
3. Install the right side head pipe and then trim it to the wheelbase (refer to the diagram). Snug the clamps as you go, but do not fully tighten them yet.
4. Install the muffler assembly, ensuring that the rear muffler measurement is correct to ensure proper tailpipe placement with an offset toward the front.
5. Use the rear muffler hanger to hold the assembly in place while measuring or tightening.
6. Install the hanger head pipe hanger and finally tighten all clamps at this point.
7. Install the right rear tail pipe and then clamp it.
8. Install the right rear hanger and then install tips, checking to ensure level and proper placement.
9. Use an MPI-wire tie to secure the brake lines and breather lines together.
10. Install the axle pipe and the left rear tail pipe, ensuring proper clearance for the spare tire and rear-end travel.
11. Install the left rear hanger using bolt MPI - 3/8-1.5 to bolt through the chassis.
12. Install the left rear tip, checking its level and position to match the right rear tip.
13. Clean any fingerprints off the tips with glass cleaner, clean the pipes with brake cleaner, and paint the added hanger black on the chassis.

Side View of Connection

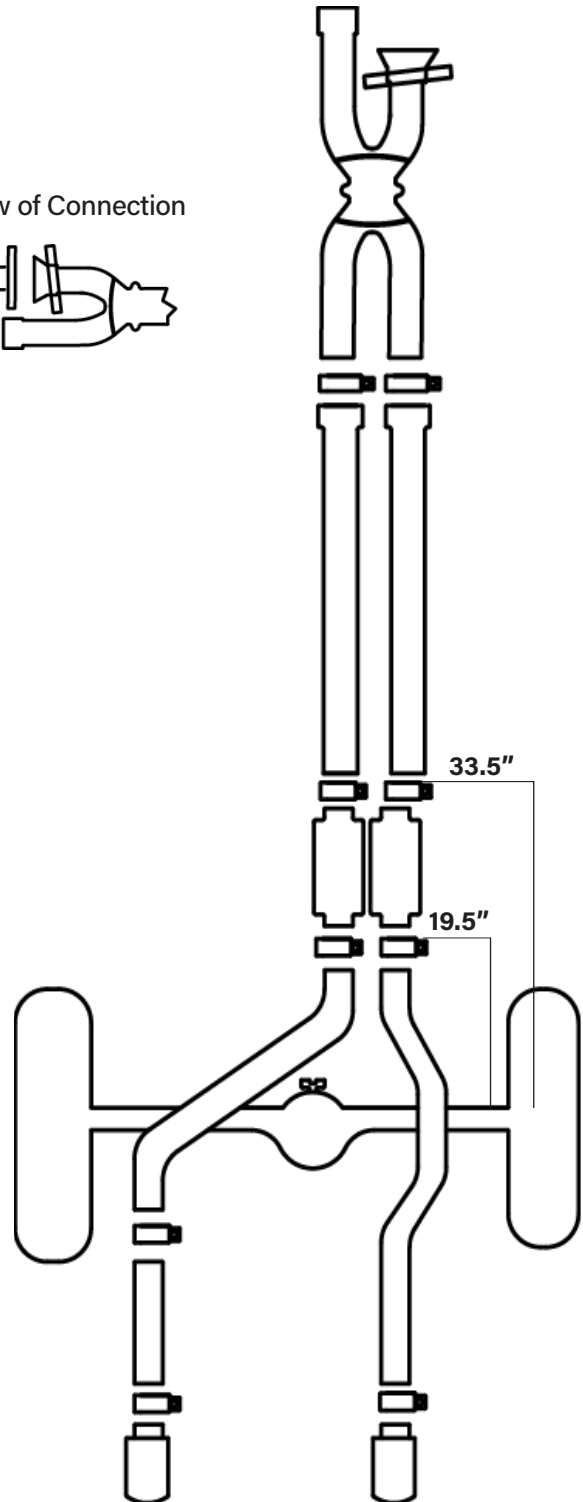
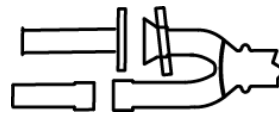

## PARTS DIAGRAM

2017-2025 FORD F250-F350  
Max: 176 - Inch Maximum  
Wheelbase

ITEM	QTY	PART NO.	DESCRIPTIONS
1.	1	Hanger - 143 - SS	Pulse Chamber Hanger ★
2.	1	MPI - PC22 - SS	Direct fit Pulse Chamber
3.	7	MPI - BCSSC250	2 1/2" SS Band Clamp
4.	2	MPI - 56 - SS	Head Pipes
5.	1	Hanger - 26 - SS	Head Pipe ▲
6.	1	Order Option	Muffler Pack
7.	1	Hanger - 27 - SS	Right Hand Muffler ●
8.	1	Hanger - 28 - SS	Left Hand Muffler ■
9.	1	MPI - 14 - SS	Right Side Tail Pipe
10.	1	Hanger -29 - SS	Right Hand Tail Pipe ◆
11.	1	MPI - 53 - SS	Left Side Axle Pipe
12.	1	MPI - 54 - SS	Left Side Tail Pipe
13.	1	Hanger - 30 - SS	Left Tail Pipe ⬠
14.	2	Order Option	Tips
15.	1	MPI-HD-003	Rubber Body
16.	2	MPI-Wire Tie	Brake Line Ties
17.	1	MPI - 3/8-1.5	LR Bolt

List is in order of installation.

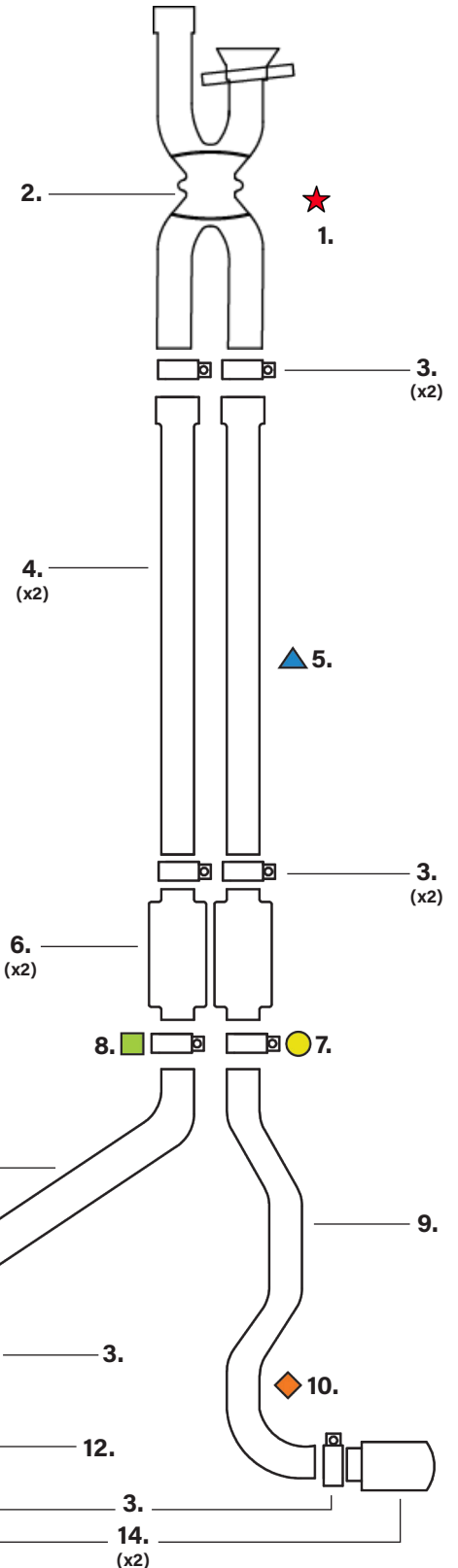

### MUFFLER OFFSET DIAGRAM

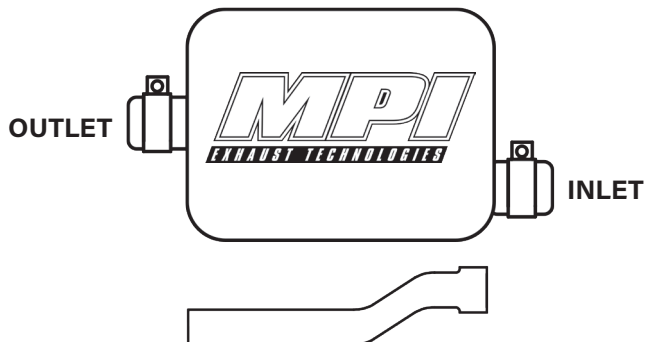

## PARTS DIAGRAM

2017 - 2025  
FORD F250 - F350  
WITH 6.2L, 6.8L,  
7.3L ENGINE  
Max: 176 - Inch  
Maximum Wheelbase

ITEM	QTY	PART NO.	DESCRIPTIONS
1.	1	Hanger - 143 - SS	Pulse Chamber Hanger ★
2.	1	MPI - PC22 - SS	Direct Fit Pulse Chamber
3.	7	MPI - BCSSC250	2 1/2" SS Band Clamp
4.	2	MPI - 56 - SS	Head Pipes
5.	1	Hanger - 26 - SS	Head Pipe ▲
6.	1	Order Option	Muffler Pack
7.	1	Hanger - 27 - SS	Right Hand Muffler ●
8.	1	Hanger - 28 - SS	Left Hand Muffler ■
9.	1	MPI - 15 - SS	Right Side Tail Pipe
10.	1	Hanger -29 - SS	Right Hand Tail Pipe ◆
11.	1	MPI - 55 - SS	Left Side Axle Pipe
12.	1	MPI - 53 - SS	Left Side Tail Pipe
13.	1	Hanger - 30 - SS	Left Tail Pipe ⬠
14.	2	Order Option	Tips
15.	1	MPI-HD-003	Rubber Body
16.	2	MPI-Wire Tie	Brake Line Ties
17.	1	MPI - 3/8-1.5	LR Bolt

List is in order of installation.

### MUFFLER OFFSET DIAGRAM

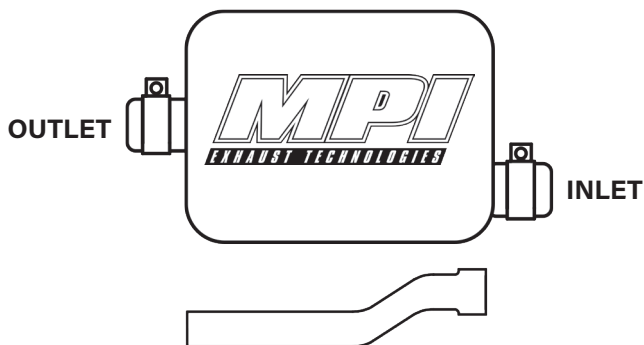

Pat. 11713700

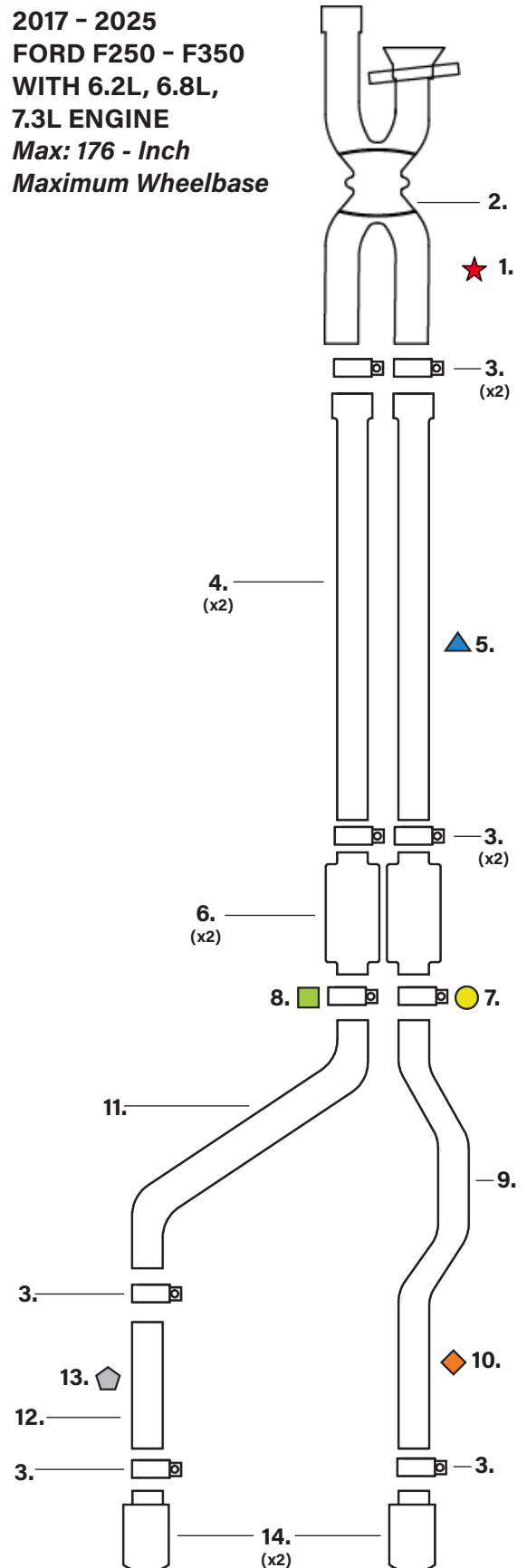



## NEW MPI EXHAUST TIPS

### *BREAK-IN PROCEDURES*

**To ensure the MPI exhaust tips maintain their finish, follow these steps carefully to avoid any unwanted alterations:**

- 1.** After installing the MPI system, clean all oils and fingerprints from the tips using a glass cleaner spray.
- 2.** Warm up the truck to full operating temperature, keeping the engine at idle without increasing RPMs. Then, allow the truck to fully cool down.
- 3.** Drive a short distance without exceeding half-throttle, varying speeds and throttle positions. DO NOT exceed ½ throttle during this time. Let the truck fully cool down before the next drive cycle.
- 4.** After this, you can drive normally but avoid full throttle for more than 10 seconds at a time.
- 5.** Avoid pulling trailers until the exhaust has been used for at least 500 miles.
- 6.** Regularly clean road salts and debris off the tips to preserve the finish.

### **QUESTIONS**

Phone: (406) 669-3286

Email: [mikespipesinc@gmail.com](mailto:mikespipesinc@gmail.com)





## WARRANTY

### CUSTOMER SUPPORT AND WARRANTY INFORMATION

Thank you for choosing an MPI Exhaust Technologies System and allowing MPI Exhaust to customize your ride today! Our friendly and knowledgeable staff is here to answer any questions. Enjoy the Sound of Perfection.

#### QUESTIONS

**ONLY contact MPI Exhaust Technologies** if any products are potentially missing or damaged during shipping, or if you have any questions about the products. **Call (406) 669-3286.**



#### INSTALLATION

Watch the tutorial YouTube videos (scan the QR code) before installing or contacting MPI Exhaust. Our knowledgeable staff have installed hundreds of these kits.



#### WARRANTY

For more information scan the QR code.

#### CONTACT

Phone: (406) 669-3286

Email: [mikespipesinc@gmail.com](mailto:mikespipesinc@gmail.com)

