



P/N: F254-C

INSTRUCTIONS PACKET

**2010 - 2016 FORD F250 - F350
WITH 6.2L ENGINE
Max: 176 - Inch Maximum Wheelbase**

F2-4



1. Remove the factory system by Unbolting the Joint in front the 2-1 resonator. Unbolting of hanger mount is required for factory removal.
2. Anti-seize surfaces of Ball with Flange, use the new bolts provided for re-installation. Leave Bottom Clamp in place for PC-22. Leave snug till step 4.
3. Install the head pipes and trim per your wheelbase. View diagram for refrence.
4. Install the muffler assembly. Make sure that the Rear Muffler measurement is correct to ensure proper tailpipe placement with the offset toward the front.
5. Install the Head Pipe Hanger and make sure to finally tighten all clamps at this point.
6. Install the Rear Hanger behind the Mufflers.
7. When the Bullnoze are installed, ensure proper rear end clearance.
8. Clean fingerprints off the tips with glass cleaner and clean the pipes with brake cleaner.

2010 - 2016 FORD
 Max: 176 - Inch Maximum
 Wheelbase

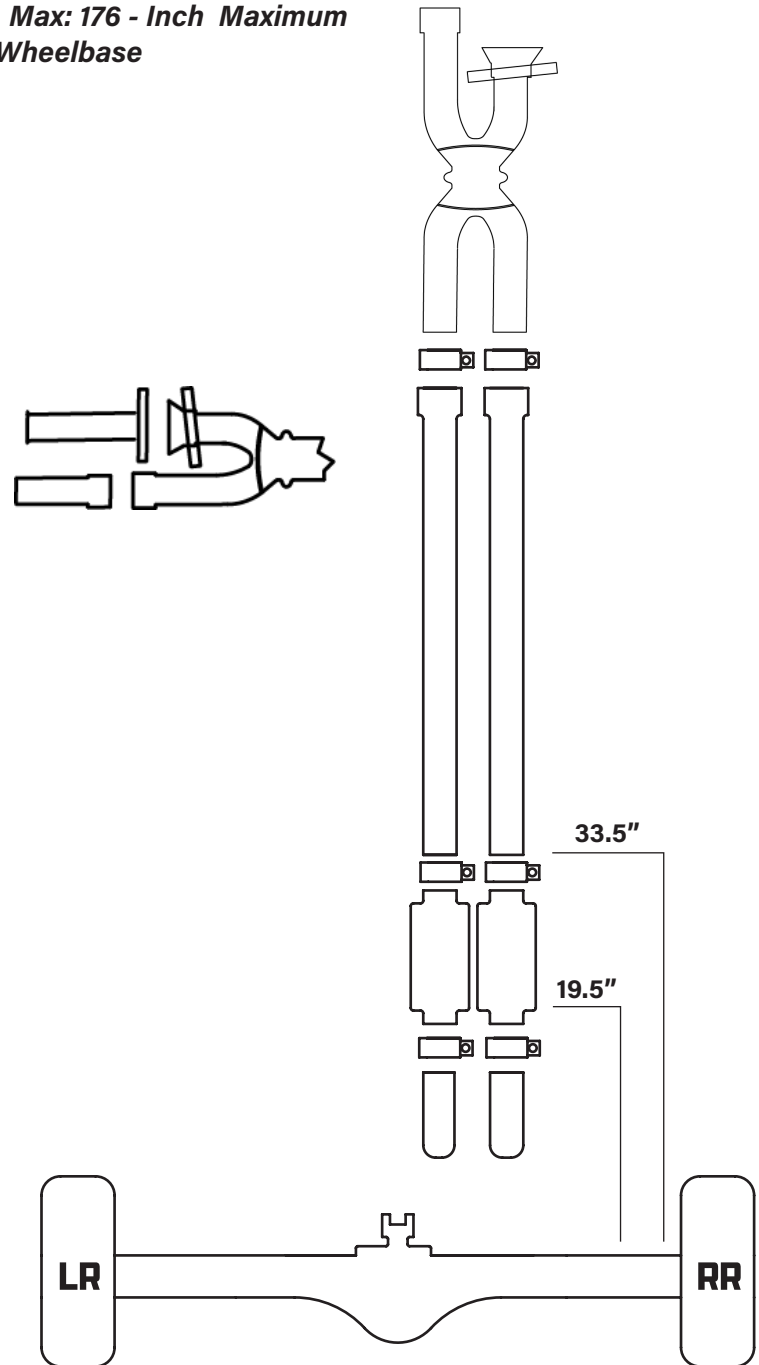

MUFFLERS

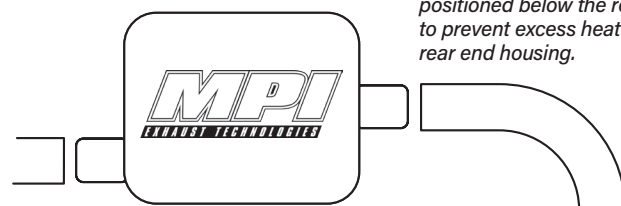

** Ensure turn downs are positioned below the rear end to prevent excess heat on the rear end housing.*

Offset Toward Engine

PARTS DIAGRAM

2010 - 2016
 FORD F250 - F350
 WITH 6.2L ENGINE
 Max: 176 - Inch
 Maximum Wheelbase

ITEM	QTY	PART NO.	DESCRIPTIONS
1.	1	Hanger - 143	PC-Hanger
2.	1	MPI - PC22	Pulse Chamber
3.	4	MPI - SC250	2.5" Clamp - Std.
4.	2	MPI - 0 - 60	Head Pipes
5.	1	Hanger - 2	Head Pipe ▲
6.	2	—	Mufflers
7.	1	Hanger - 3	RH Muffler Hanger ●
8.	1	Hanger - 4	LH Muffler Hanger ■
9.	2	MPI - 1	Turn Downs

MUFFLER OFFSET DIAGRAM

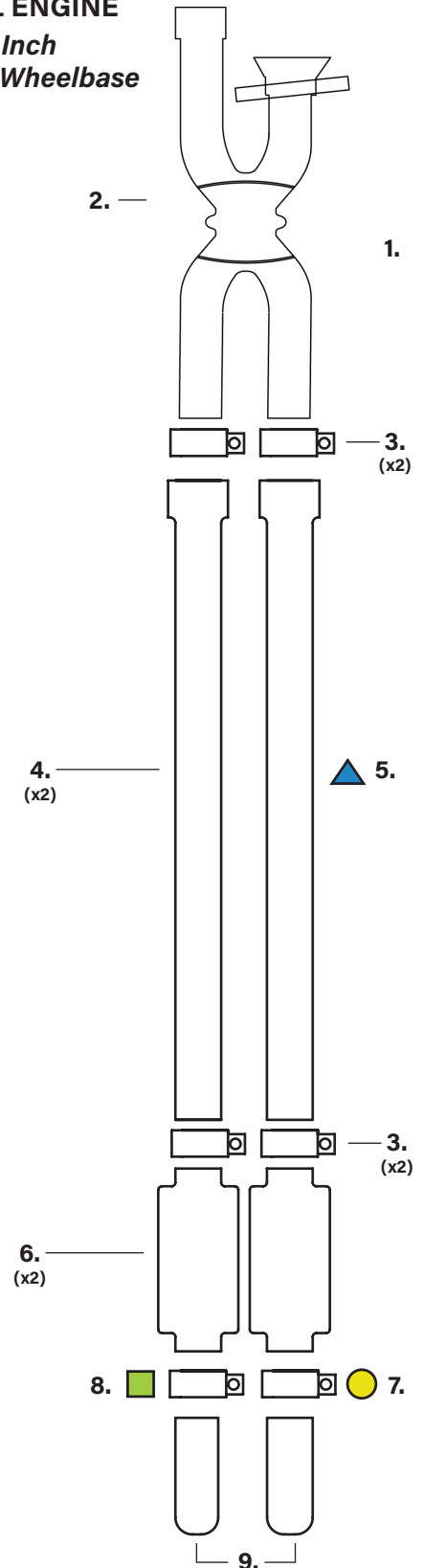



WARRANTY



CUSTOMER SUPPORT AND WARRANTY INFORMATION

Thank you for choosing an MPI Exhaust Technologies System and allowing MPI Exhaust to customize your ride today! Our friendly and knowledgeable staff is here to answer any questions. Enjoy the Sound of Perfection.

QUESTIONS

ONLY contact MPI Exhaust Technologies if any products are potentially missing or damaged during shipping, or if you have any questions about the products. **Call (406) 669-3286.**



INSTALLATION

Watch the tutorial YouTube videos (scan the QR code) before installing or contacting MPI Exhaust. Our knowledgeable staff have installed hundreds of these kits.



WARRANTY

For more information scan the QR code.

CONTACT

Phone: (406) 669-3286

Email: mikespipesinc@gmail.com

