



***DOWNLOAD COLOUR  
INSTALL MANUALS AT  
[www.bddiesel.com](http://www.bddiesel.com)***



# **BD Diesel Ford Exhaust Manifold Kit**

2008 – 2010 Ford 6.4L Power Stroke F250-550

<b>1041482</b>	<b>Exhaust Manifold Kit</b>
<b>1041487</b>	<b>Single Side Exhaust Manifold Kit</b>

## Table of Contents

Table of Contents.....2

Kit Contents .....2

Optional Parts .....3

Installation.....**Error! Bookmark not defined.**

Tools Required for Installation .....3

Installation.....3

LH Exhaust Manifold.....3

Removal .....3





Installation .....7





RH Exhaust Manifold .....14

Removal .....14

Installation .....20

## Kit Contents

1041482 (Exhaust Manifold Pair Kit)			
1401482	MS19312	FT-11508416	1200208
			
Exhaust Manifold	Exhaust Manifold Gasket	Exhaust Manifold Outlet Stud	Plug; 1/8" NPT Hex
<b>Qty: 2</b>	<b>Qty: 2</b>	<b>Qty: 6</b>	<b>Qty: 2</b>

1041487 (Single Exhaust Manifold Kit)			
1401482	MS19312	FT-11508416	1200208
			
Exhaust Manifold	Exhaust Manifold Gasket	Exhaust Manifold Outlet Stud	Plug; 1/8" NPT Hex
<b>Qty: 1</b>	<b>Qty: 1</b>	<b>Qty: 3</b>	<b>Qty: 1</b>

## Optional Parts

Description	Part #
Turbo Up Pipe Gasket (4)	B32256
EGR Cooler Coolant Outlet Hose Clamp	8287
EGR Cooler Outlet Studs (2)	W302633
Horizontal EGR Cooler Outlet Nuts (2)	W300050
EGR Coolant Supply Tube Assembly O-Ring Seal	W301924
EGR Coolant Supply Tube Bolt	W300002
EGR Coolant Supply Tube Bolt	W300009
EGR Coolant Supply Tube Clamp	8287
Oil Level Indicator Tube O-Ring Seal	6754
Oil Level Indicator Tube Nut	W300050
Horizontal EGR Cooler Outlet Gasket	9H454
Manifold Bolts (8)	W302675
Horizontal EGR Cooler Bolts (4)	W302550
Manifold Stud Bolts (4)	W302647

## Tools Required for Installation

- 10-16mm Socket & Wrench
- 7/16", 9/16" Deep Socket
- Half-moon Wrench 10mm/12mm & 11mm/13mm
- 11 and 12mm Allen Sockets
- Pry Bar
- Torque Wrench
- Scraper
- Side Cutter

## Installation

Disconnect both vehicle batteries for safety.

### LH Exhaust Manifold

#### Removal

Remove the 3 turbo inlet pipe-to-turbo bolts and the 3 inlet pipe-to-exhaust manifold nuts.

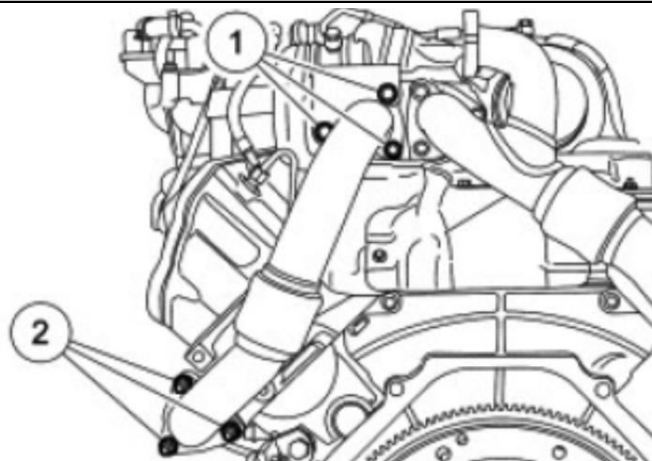

Drain the coolant and  
remove the degas bottle.

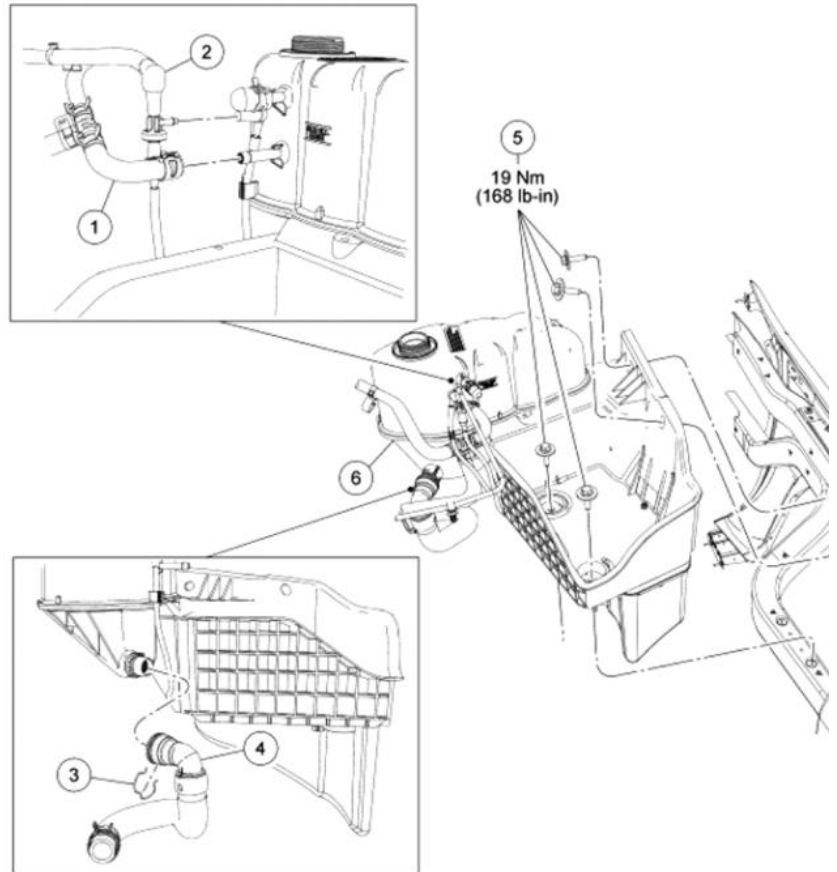

- 1 – EGR coolant return hose
- 2 – Vacuum hose connector
- 3 – Degas bottle-to-engine hose spring clip
- 4 – Degas bottle-to-engine hose
- 5 – Degas bottle bolts (2)
- 6 – Degas bottle

Remove the LH front wheel/tire and the LH fender splash shield.

Remove the oil level indicator by  
removing the nut and bolt that secure  
it. Remove the O-ring seal.

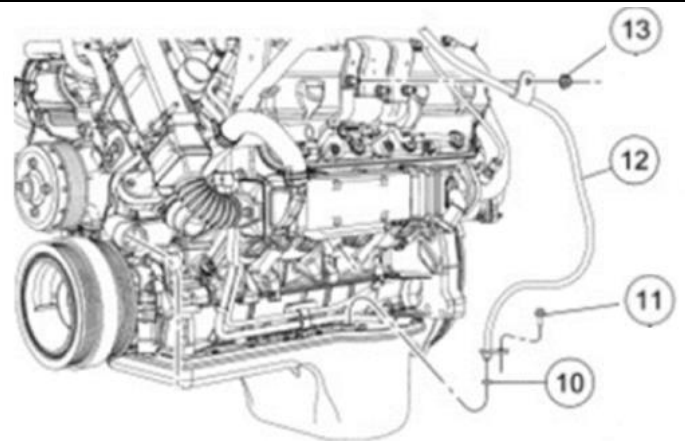

- 10 - Oil level indicator tube O-ring
- 11 - Oil level indicator tube bolt
- 12 - Oil level indicator tube
- 13 - Oil level indicator tube nut

Disconnect the anti-lock module electrical connector and position aside.

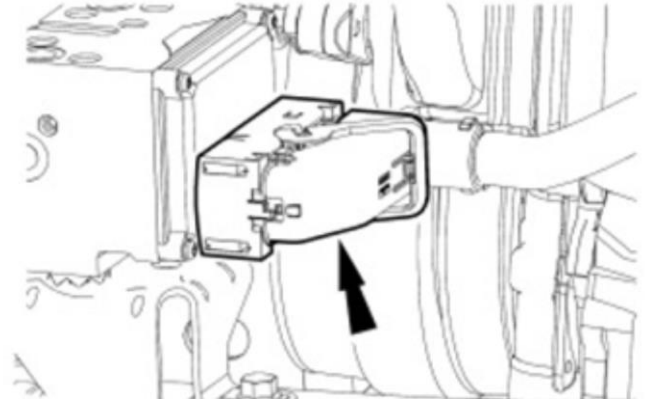

Loosen the clamps for the EGR cooler coolant supply hose.

Remove the bolts and the EGR cooler coolant supply tube. Remove the clamps on the hose and the O-ring seal on the tube.

**Note:** The coolant hose clamps used on this engine are constant tension worm gear clamps. Standard worm gear clamps **cannot** be used.

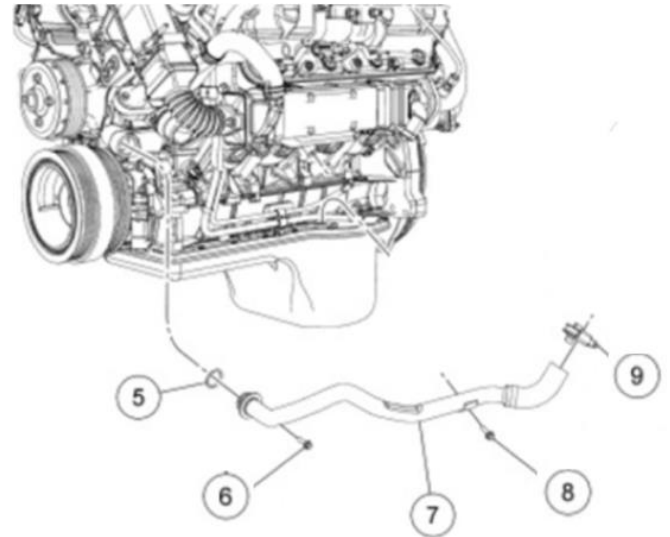

- |   |                                       |
|---|---------------------------------------|
| 5 | – EGR coolant supply tube O-ring seal |
| 6 | – EGR coolant supply tube bolt        |
| 7 | – EGR coolant supply tube assembly    |
| 8 | – EGR coolant supply tube bolt        |
| 9 | – EGR coolant supply tube clamp       |

Loosen the clamps and disconnect the EGR cooler outlet coolant hose.

Remove the 2 nuts for the horizontal EGR cooler outlet.

Remove the 2 studs for the horizontal EGR cooler outlet. Remove the gasket.

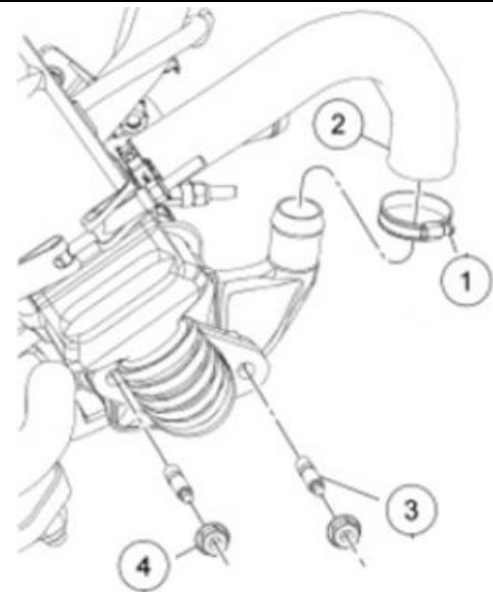

- |   |  |
|---|--|
| 1 | – EGR cooler coolant outlet hose clamp |
| 2 | – EGR cooler coolant outlet hose       |
| 3 | – EGR cooler outlet stud (2)           |
| 4 | – Horizontal EGR cooler outlet nut (2) |

Remove the bolt to the steering shaft and disconnect the shaft.

**IMPORTANT!!!** Do not allow steering wheel to turn while the shaft is disconnected.

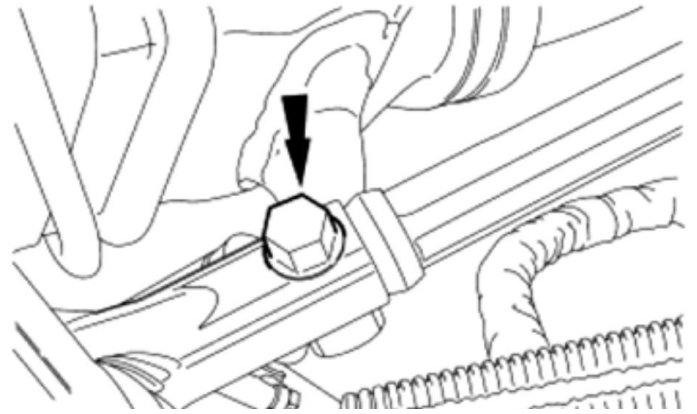

Remove the 2 nuts, separate the clamps and remove the horizontal EGR cooler.

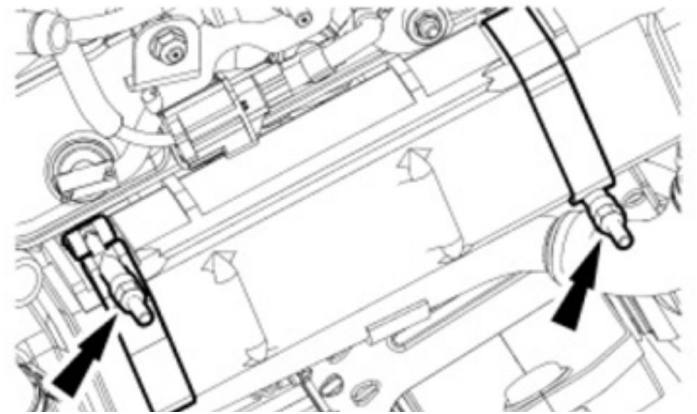

Remove the 4 horizontal EGR cooler bracket bolts and the bracket. Discard the bolts.

Remove the 4 exhaust manifold bolts, the exhaust manifold and the exhaust manifold gasket.

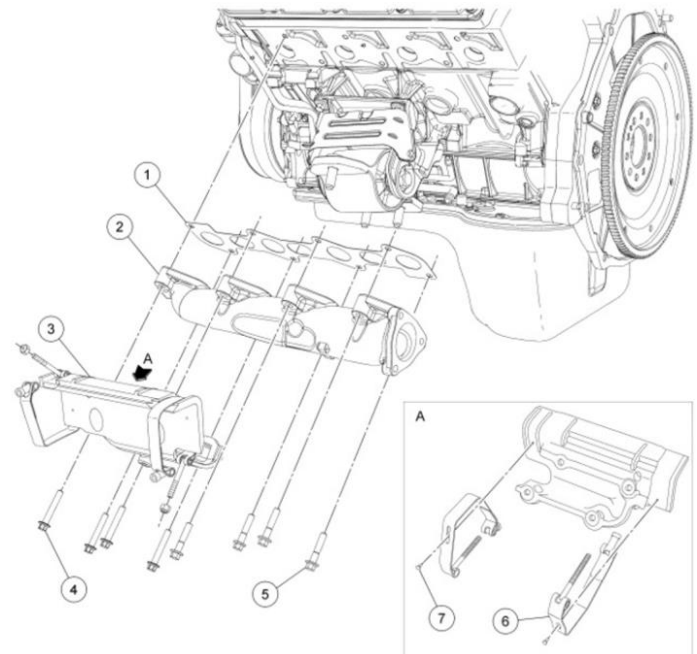

- |   |   |
|---|---|
| 1 | – Exhaust manifold gasket                 |
| 2 | – Exhaust manifold                        |
| 3 | – Horizontal EGR cooler bracket           |
| 4 | – Horizontal EGR cooler bracket bolts (4) |
| 5 | – Exhaust manifold bolt (4)               |
| 6 | – Clamp (2)                               |
| 7 | – Pin (2)                                 |

## Installation

Install three new studs on the outlet of the exhaust manifold.

Position the new gasket and the LH exhaust manifold. Loosely install the 4 exhaust manifold bolts.

Position the horizontal EGR cooler bracket and loosely install the 4 bolts.

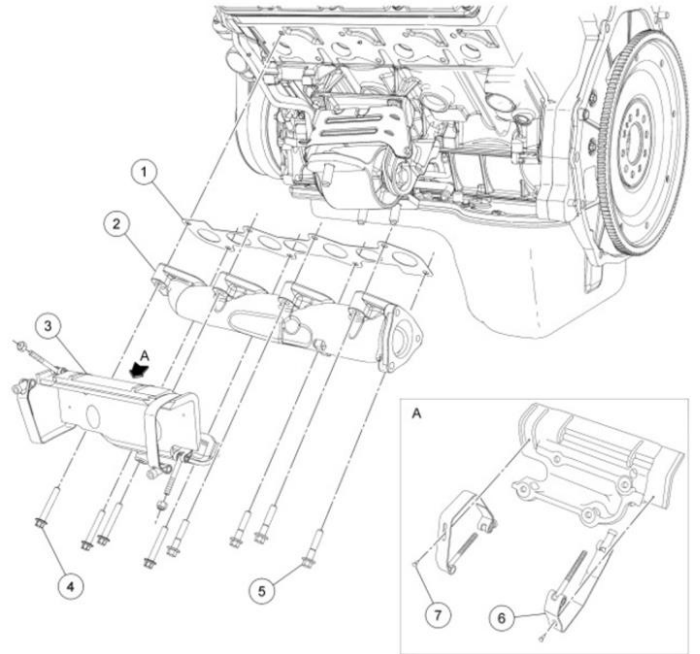

- 1 – Exhaust manifold gasket
- 2 – Exhaust manifold
- 3 – Horizontal EGR cooler bracket
- 4 – Horizontal EGR cooler bracket bolts (4)
- 5 – Exhaust manifold bolt (4)
- 6 – Clamp (2)
- 7 – Pin (2)

Tighten the exhaust manifold bolts in 2 stages in the sequence shown in the figure.

- Stage 1: Tighten to **25 Nm (18lb-ft)**
- Stage 2: Tighten again to **25 Nm (18lb-ft)**

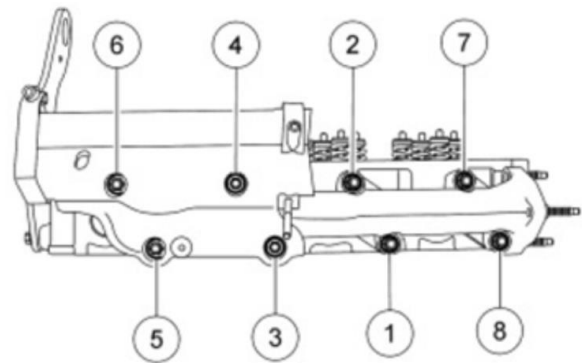

Insert the horizontal EGR cooler into the slots in the horizontal EGR cooler bracket and install the 2 clamp nuts. Tighten the clamps for the horizontal EGR cooler in 3 stages.

- Stage 1: Tighten to **10 Nm (89lb-in)**
- Stage 2: Loosen the clamps **720 degrees**
- Stage 3: Tighten to **8 Nm (71lb-in)**



Position the steering shaft into the housing and install the steering shaft bolt.

Tighten to **48 Nm (35lb-ft)**.

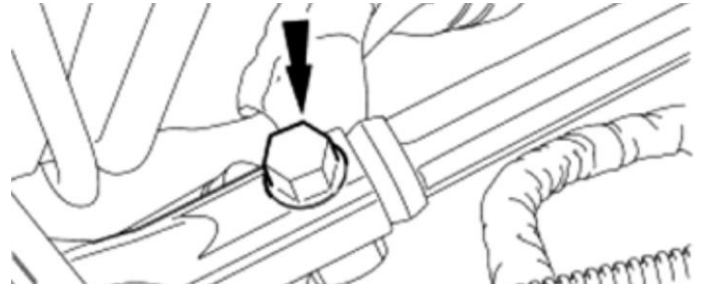

Position the horizontal EGR cooler outlet gasket and install the 2 studs.

Tighten to **17 Nm (12lb-ft)**.

Install the 2 horizontal EGR cooler outlet nuts.

Tighten to **31 Nm (23lb-ft)**.

Using the clamp, connect the EGR cooler coolant outlet hose to the horizontal EGR cooler.

Tighten to **4 Nm (35lb-in)**.

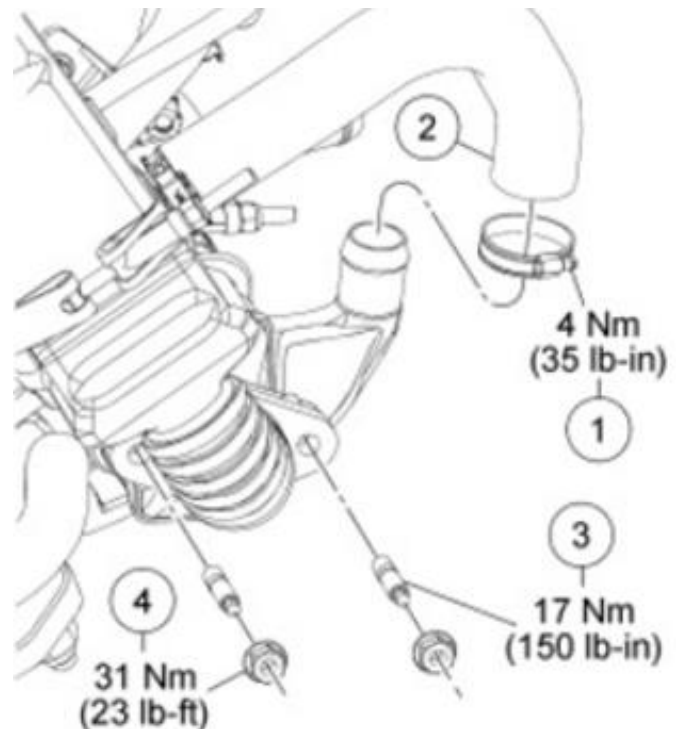

- |  |
|--|
| 1 – EGR cooler coolant outlet hose clamp |
| 2 – EGR cooler coolant outlet hose       |
| 3 – EGR cooler outlet stud (2)           |
| 4 – Horizontal EGR cooler outlet nut (2) |

Position the clamp and the O-ring seal and install the EGR cooler coolant supply tube and bolts.

Tighten to **13 Nm (115lb-in)**.

Tighten the clamp for the EGR cooler supply hose.

Tighten to **4 Nm (35lb-in)**.

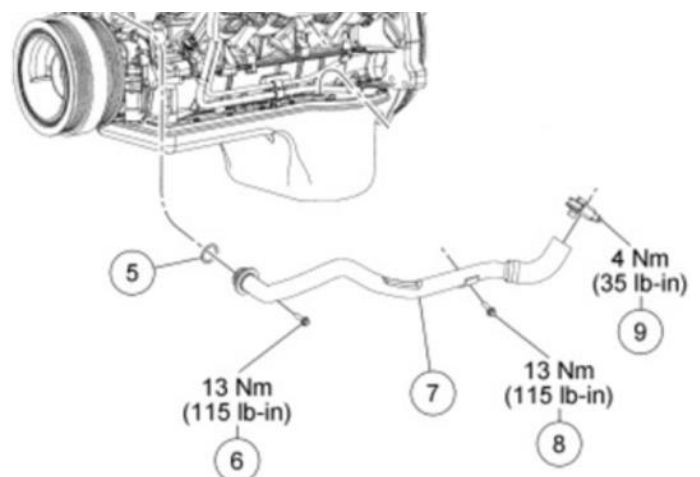

- |   |
|---|
| 5 – EGR coolant supply tube O-ring seal |
| 6 – EGR coolant supply tube bolt        |
| 7 – EGR coolant supply tube assembly    |
| 8 – EGR coolant supply tube bolt        |
| 9 – EGR coolant supply tube clamp       |

Connect the anti-lock module electrical connector.

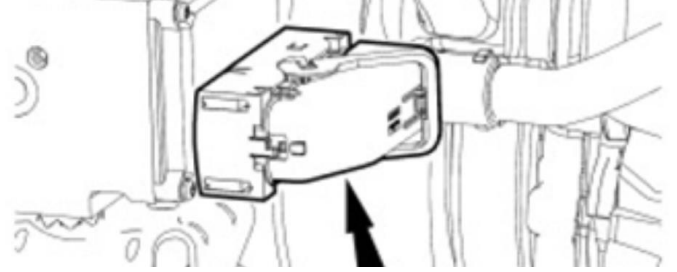

Position the oil level indicator tube, and the oil level indicator tube O-ring.

Install the bolt.

Tighten to **13 Nm (115lb-in)**.

Install the nut for the oil level indicator tube.

Tighten to **31 Nm (23lb-ft)**.

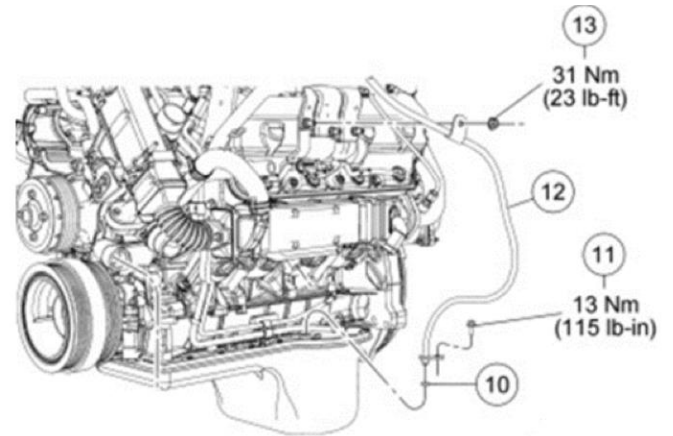

- |                                      |
|--------------------------------------|
| 10 - Oil level indicator tube O-ring |
| 11 - Oil level indicator tube bolt   |
| 12 - Oil level indicator tube        |
| 13 - Oil level indicator tube nut    |

Install the LH fender splash shield, and wheel/tire.

Install the degas bottle.

- 1 – EGR coolant return hose
- 2 – Vacuum hose connector
- 3 – Degas bottle-to-engine hose spring clip
- 4 – Degas bottle-to-engine hose
- 5 – Degas bottle bolts (2)
- 6 – Degas bottle

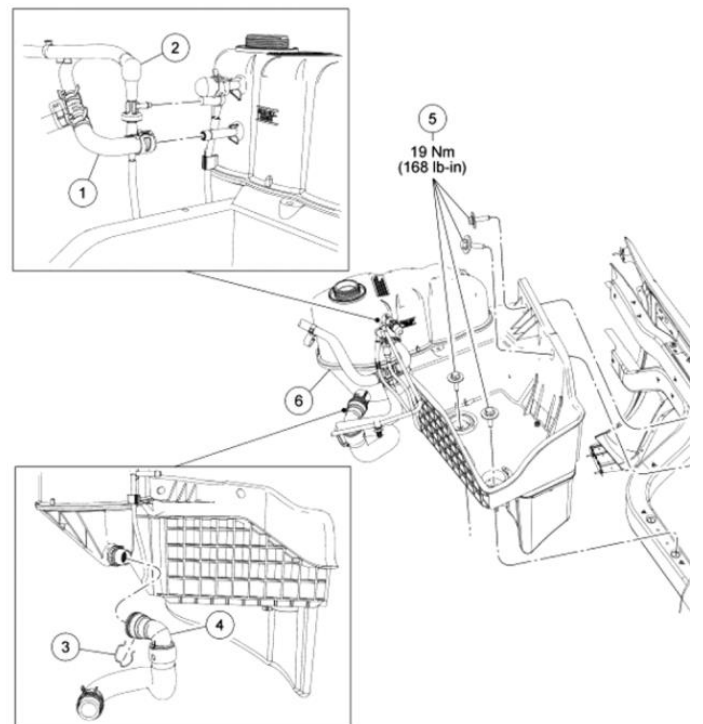

Install the LH turbo inlet pipe-to-turbo bolts and inlet pipe-to-exhaust manifold nuts.

Tighten the top 2 bolts on the turbo end to **24 Nm (18lb-ft)**.

Tighten the bottom 2 nuts on the exhaust manifold end to **31 Nm (23lb-ft)**.

Refer to the next 4 pages for the steps to tighten the remaining bolt and nut.

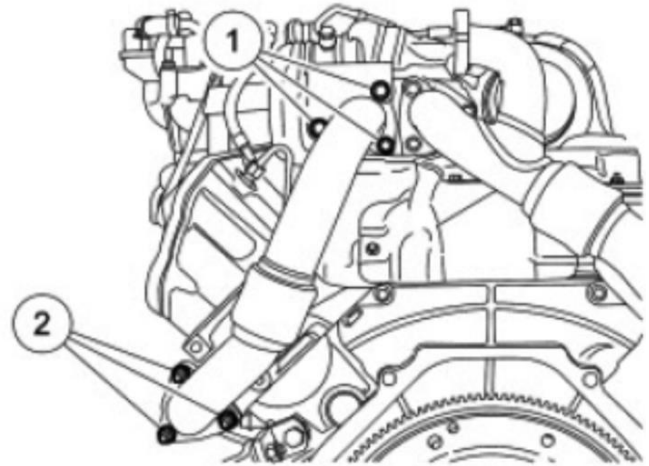

### Turbo Inlet Bottom Bolt:

Due to limited access, one of the specific Half-moon wrenches and other tools described must be used to correctly tighten the fasteners in this step. Failure to follow this instruction may result in engine failure.

**Note:** To complete this step, it will be necessary to use the following tools:

- A 3/8-in drive torque wrench that is 241 mm (9.5 in) or 368 mm (14.5 in) from center of the handle to the center of the square drive.
- One of the 10-mm/12-mm Half-moon wrenches listed in the following chart.
- A 12-mm Allen socket (to drive the Half-moon wrench).

**Note:** LH shown, RH similar

**Note:** To obtain the required torque value of **24 Nm (18 ft-lbs)**, it will be crucial to orient the Half-moon wrench in the direction shown and 180 degrees (Straight out) from the torque wrench. The torque wrench must be set to the value specified in the following chart for the Half-moon wrench and torque wrench length being used. Tighten the turbocharger inlet pipe-to-turbocharger bottom bolt.

Refer to the following chart for torque wrench setting, based on the specific Half-moon wrench and torque wrench length being used.

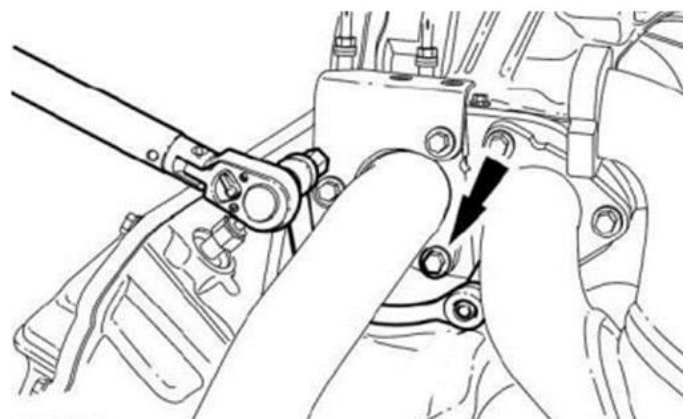

<i>Torque Chart - Turbocharger Inlet Pipe-to-Turbocharger, Bottom Bolt</i>					
Half-Moon Wrench Brand	Wrench Part Number	Wrench Size	Torque Wrench Length	Torque Wrench Setting	
				Nm	lb-in
Comwell®	BWM- 1012MM	10/12 mm	9.5 in	20	177
Gear Wrench®	9851	10/12 mm	9.5 in	18	159
Matco®	MHM1012	10/12 mm	9.5 in	18	159
Mac®	HMM1012R	10/12 mm	9.5 in	15	133
Snap-On®	CXM1012	10/12 mm	9.5 in	18	159
Cornwell®	BWM- 1012MM	10/12 mm	14.5 in	19	168
Gear Wrench®	9851	10/12 mm	14.5 in	18	159
Matco®	MHM1012	10/12 mm	14.5 in	18	159
Mac®	HMM1012R	10/12 mm	14.5 in	16	142
Snap-On®	CXM1012	10/12 mm	14.5 in	18	159
<b>NOTE:</b> To achieve the required torque of <b>25 Nm (18 lb-ft)</b> , the torque wrench must be set to the appropriate Torque Wrench Setting listed in this chart.					

### Exhaust Manifold Outlet Top Nut:

Due to limited access, one of the specific Half-moon wrenches and other tools described must be used to correctly tighten the fasteners in this step. Failure to follow this instruction may result in engine failure.

**Note:** To complete this step, it will be necessary to use the following tools:

- A 3/8-in drive torque wrench that is 368 mm (14.5 in) or 381 mm (15.0 in) from the center of the handle to the center of the square drive.
- One of the 11-mm/13-mm Half-moon wrenches listed in the following chart.
- A 11-mm Allen socket (to drive the Half-moon wrench).

**Note:** To obtain the required torque value of **31 Nm (23 ft-lbs)**, it will be crucial to orient the Half-moon wrench in the direction shown and 180 degrees (straight out) from the torque wrench. The torque wrench must be set to the value specified in the following chart for the Half-moon wrench and torque wrench length being used.

Tighten the LH turbocharger inlet pipe-to-LH exhaust manifold nut.

Refer to the following chart for torque wrench setting, based on the specific Half-moon wrench and torque wrench length being used.

**Note:** LH shown, RH similar

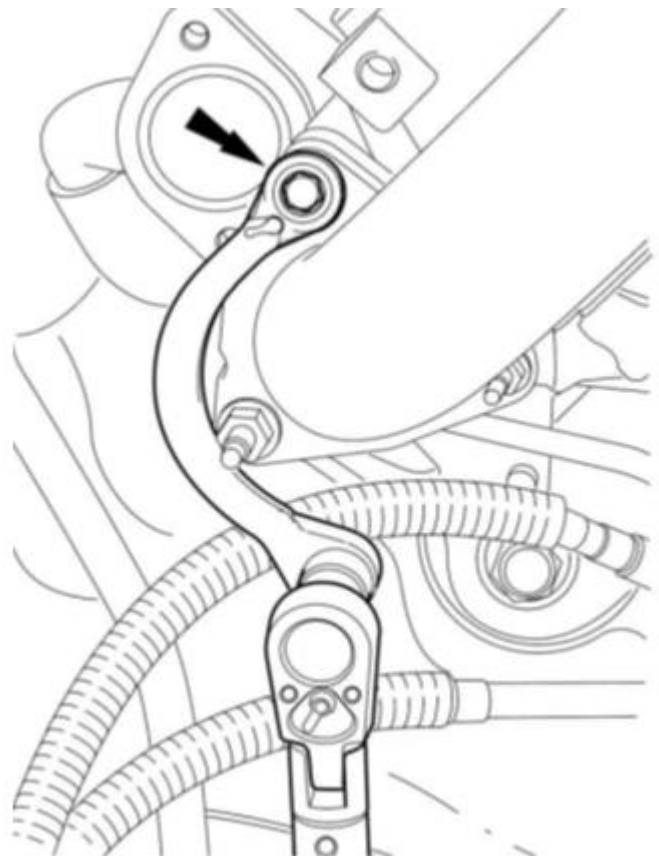

<i>Torque Chart – Turbocharger Inlet Pipe-to-Exhaust Manifold, Upper Nut</i>					
Half-Moon Wrench Brand	Wrench Part Number	Wrench Size	Torque Wrench Length	Torque Wrench Setting	
				Nm	lb-ft
Comwell®	BWM-1113MM	11/13 mm	14.5 in	47	35
Gear Wrench®	9852	11/13 mm	14.5 in	46	34
Matco®	MHM1113	11/13 mm	14.5 in	46	34
Mac®	HMM1113R	11/13 mm	14.5 in	46	34
Snap-On®	CXM1113	11/13 mm	14.5 in	46	34
Cornwell®	BWM-1113MM	11/13 mm	14.5 in	49	36
Gear Wrench®	9852	11/13 mm	14.5 in	47	35
Matco®	MHM1113	11/13 mm	14.5 in	47	35
Mac®	HMM1113R	11/13 mm	14.5 in	47	35
Snap-On®	CXM1113	11/13 mm	14.5 in	47	35
<b>NOTE:</b> To achieve the required torque of <b>62 Nm (46 lb-ft)</b> , the torque wrench must be set to the appropriate Torque Wrench Setting listed in this chart.					

## ***RH Exhaust Manifold***

### ***Removal***

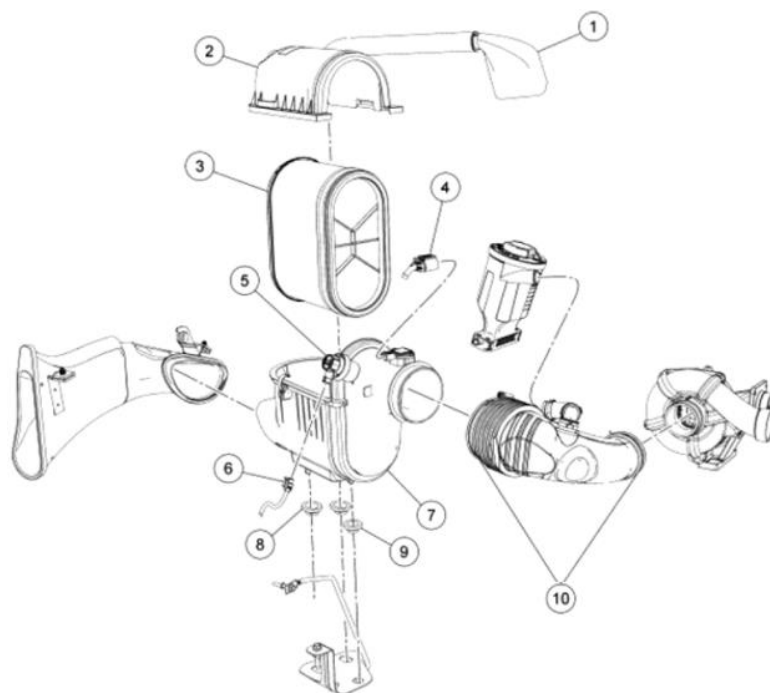

Remove the air cleaner assembly.

- 1 – Secondary air intake
- 2 – Air Cleaner (ACL) outlet housing
- 3 – ACL Element
- 4 – Mass air flow (MAF) sensor electrical connector
- 5 – Restriction gauge
- 6 – Restriction gauge electrical connector
- 7 – ACL housing
- 8 – ACL housing isolator, oval (2)
- 9 – ACL housing isolator, round
- 10 – ACL outlet pipe

Remove the auxiliary air intake tube.

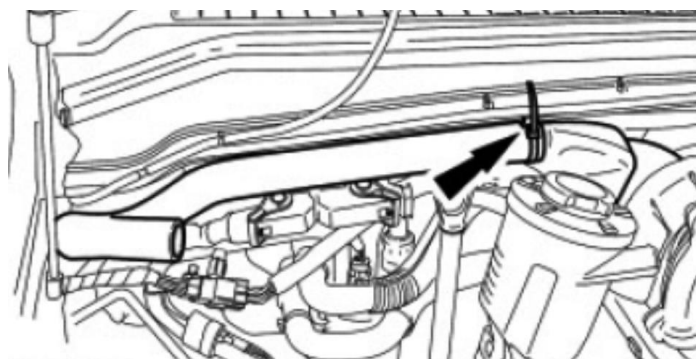

**For vehicles with A/C:** Recover the A/C system.  
**IMPORTANT!!!** Specialized equipment is required to do this procedure.

With the vehicle in neutral, position it on a hoist.

Remove the two exhaust downpipe-to-oxidation catalytic converter (OC) pipe bolts.

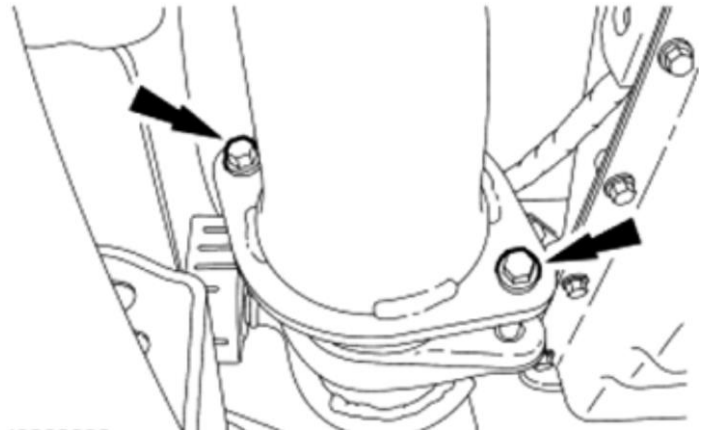

Remove the upper exhaust downpipe clamp. Position aside the exhaust downpipe. Remove the exhaust downpipe gasket.

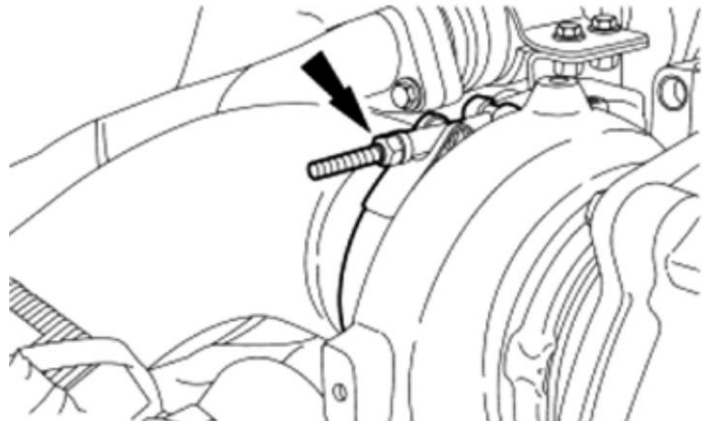

Disconnect the exhaust pressure sensor tube from the EGR-OC pipe.

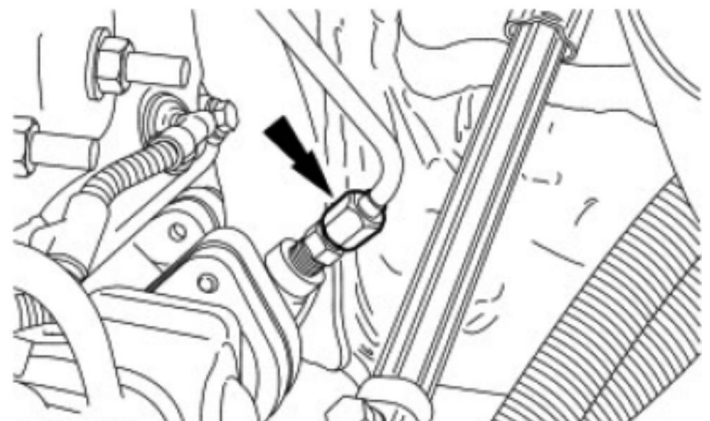

Remove the EGR-OC pipe bracket-to-bracket bolt and washer.

Remove the bracket-to-cylinder head bolt, washers and bracket.

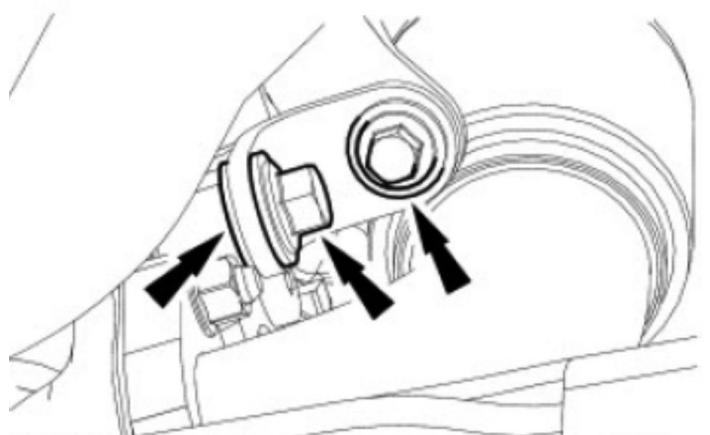

Remove the 2 EGR-OC-to-EGR cooler bolts.



Remove the 2 EGR-OC pipe bolts and the 2 EGR-OC-to-turbo bracket bolts. Position the EGR-OC pipe aside.

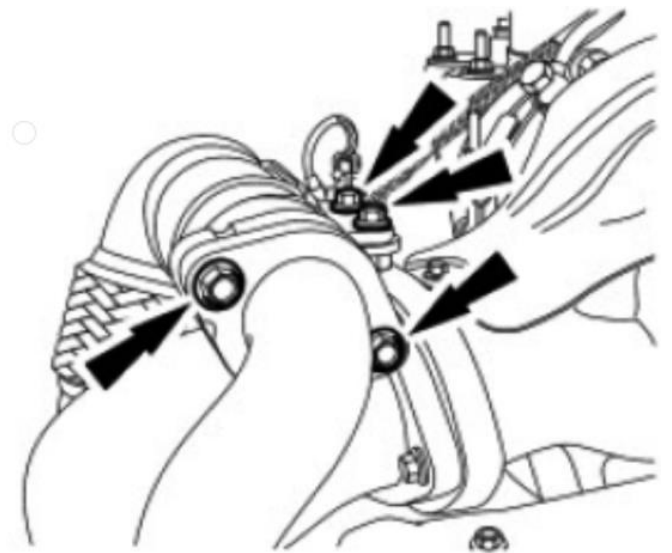

Remove the front right wheel/tire, and the splash shield.

Remove the exhaust gas recirculation temperature (EGRT) sensor from the RH turbo inlet pipe.

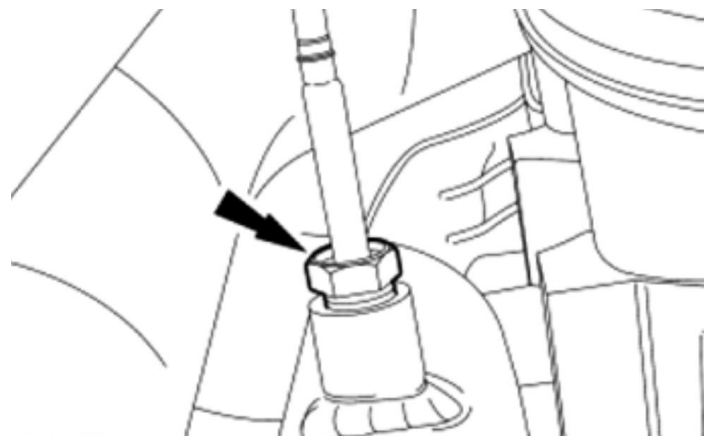

Remove the 3 RH turbo inlet pipe-to-exhaust manifold nuts.

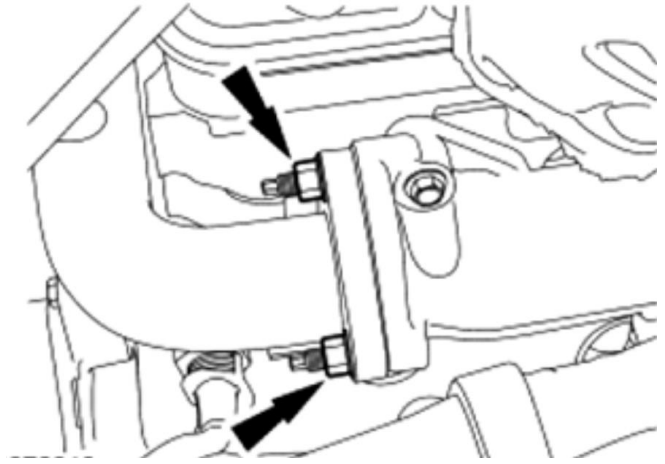

Remove the 3 RH turbocharger inlet pipe-to-exhaust manifold studs.

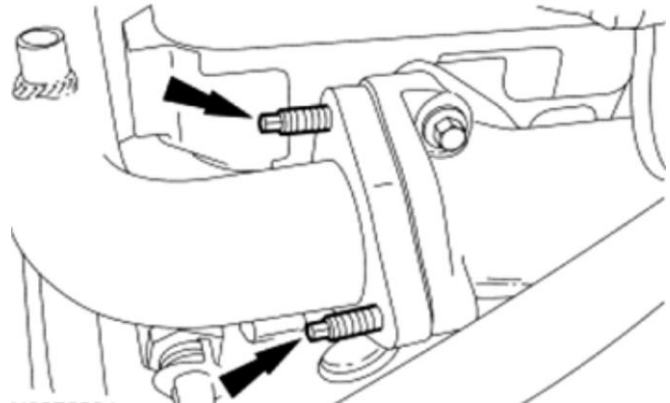

Remove the 3 RH turbo inlet pipe bolts. Position the inlet pipe aside.

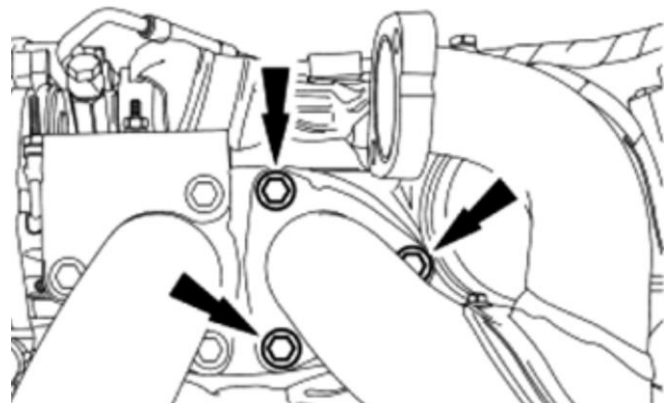

Remove the battery cable bracket nut and position the battery cable aside.

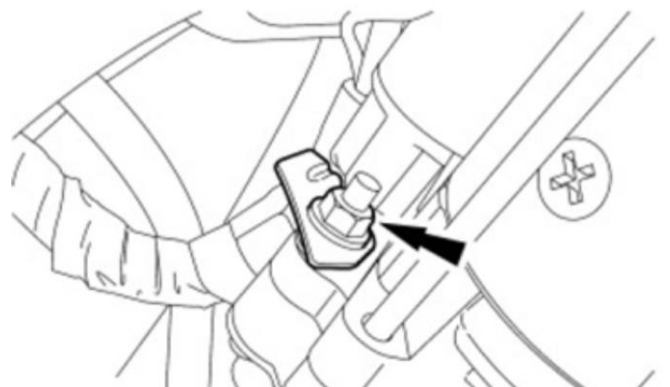

Remove the cover for the starter terminals.

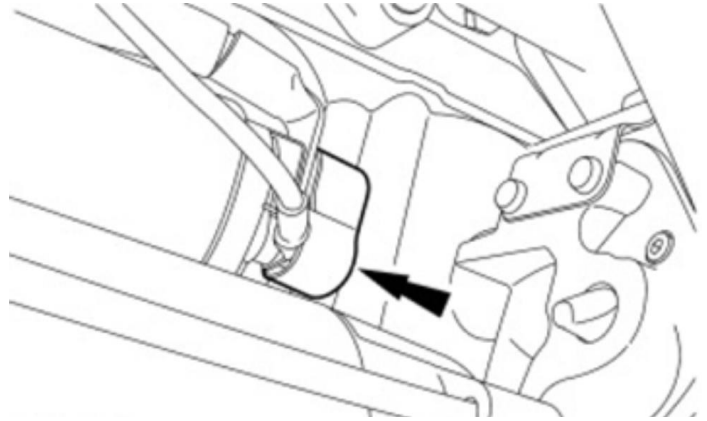

Remove the 2 retaining nuts for the starter solenoid wiring. Position the starter wiring aside.

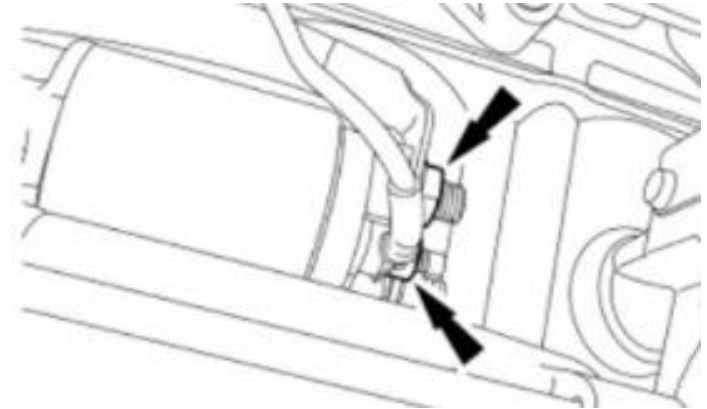

**Vehicles with A/C:** Disconnect the A/C compressor wire retainer. Position the wiring aside.

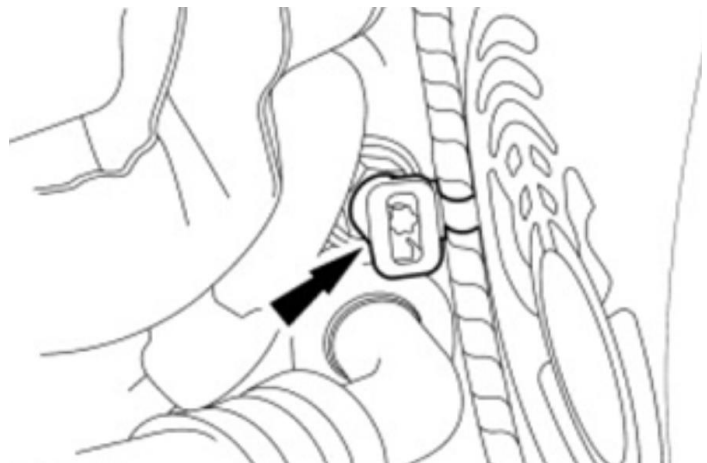

Remove the 2 nuts and position aside the A/C hose. Plug or cap the openings.

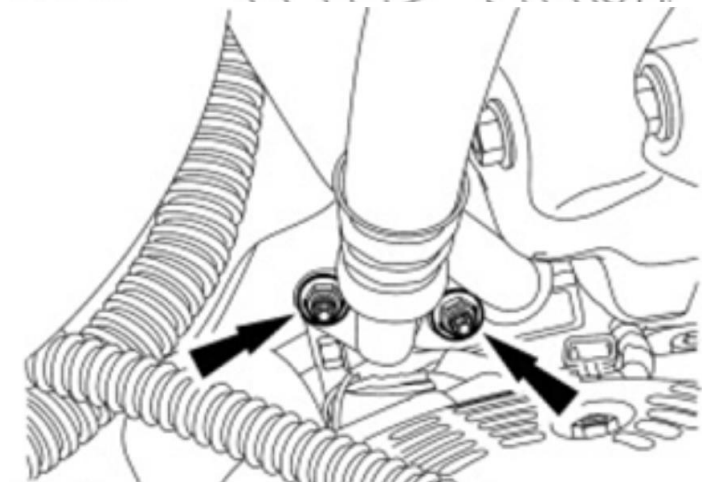

**Vehicles with automatic transmissions:** Remove the retaining nut and position the transmission fluid indicator tube off the stud.

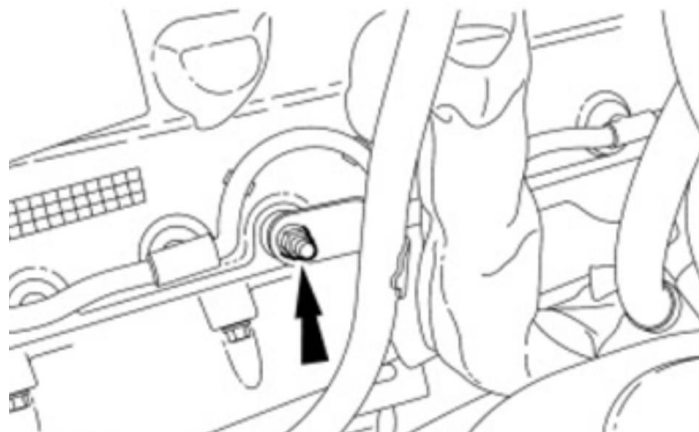

Remove the 3 bolts and nuts for the heat shield. Remove the heat shield.

Remove the 3 spacers from the exhaust manifold stud bolts.

Remove the 4 studs and 4 stud bolts. Remove the exhaust manifold and exhaust manifold gasket.

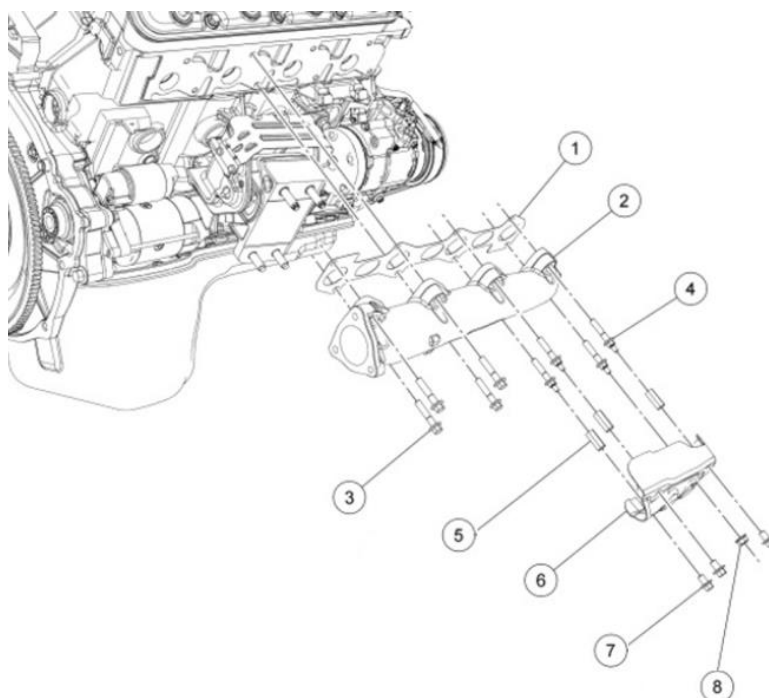

- |   |                                  |
|---|----------------------------------|
| 1 | – Exhaust manifold gasket        |
| 2 | – Exhaust manifold               |
| 3 | – Exhaust manifold bolt (4)      |
| 4 | – Exhaust manifold stud bolt (4) |
| 5 | – Spacer (3)                     |
| 6 | – Heat shield                    |
| 7 | – Heat shield bolt (3)           |
| 8 | – Heat shield retaining nut      |

## Installation

Install three new studs on the outlet of the exhaust manifold.

Position the new gasket and the RH exhaust manifold. Install the 4 stud bolts and the 4 bolts. Tighten in 2 stages in the sequence shown.

- Stage 1: Tighten to **25 Nm (18lb-ft)**
- Stage 2: Tighten again to **25 Nm (18lb-ft)**

Install the 3 spacers on the exhaust manifold stud bolts.

Tighten to **19 Nm (168lb-in)**.

Position the exhaust manifold heat shield. Install the nut and 3 bolts.

Tighten to **19 Nm (168lb-in)**.

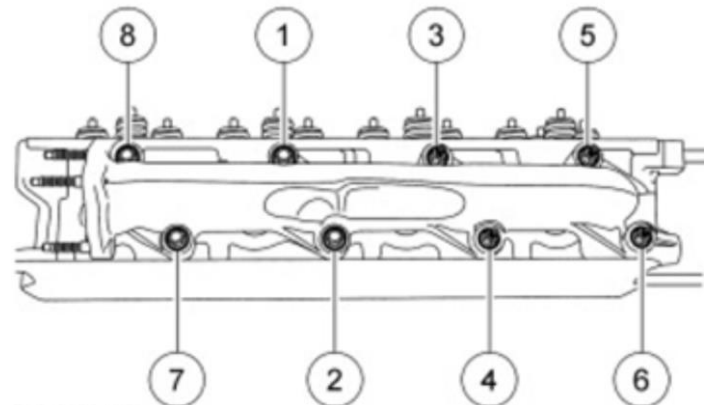
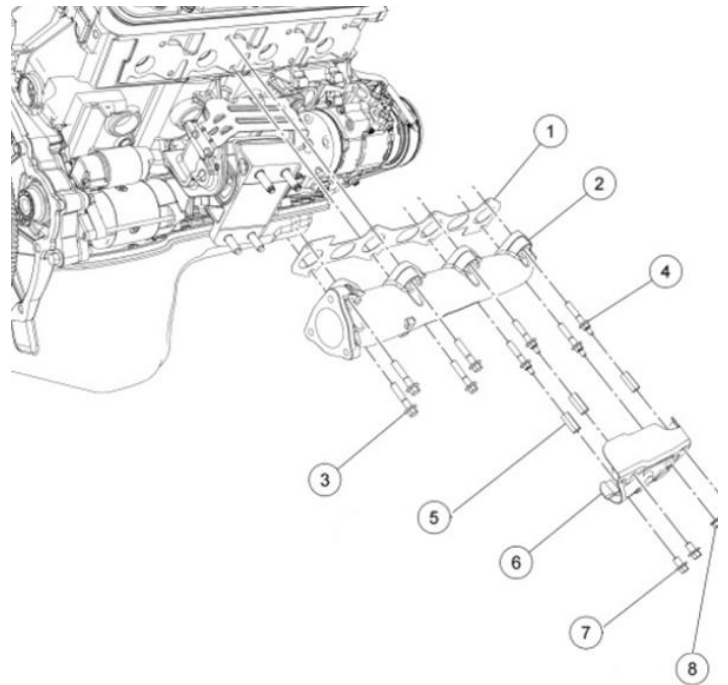

- |   |                                  |
|---|----------------------------------|
| 1 | – Exhaust manifold gasket        |
| 2 | – Exhaust manifold               |
| 3 | – Exhaust manifold bolt (4)      |
| 4 | – Exhaust manifold stud bolt (4) |
| 5 | – Spacer (3)                     |
| 6 | – Heat shield                    |
| 7 | – Heat shield bolt (3)           |
| 8 | – Heat shield retaining nut      |

**Vehicles with automatic transmission:** Position back the transmission fluid level indicator tube and install the nut.

Tighten to **8 Nm (71lb-in)**.

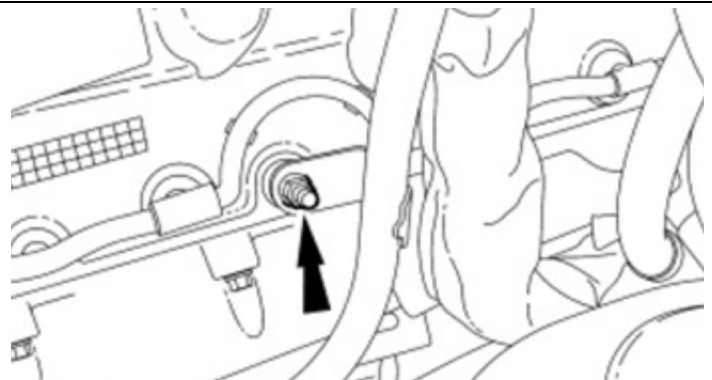

**Vehicles with A/C:** Install the A/C hoses and 2 nuts.

Tighten to **15 Nm (133lb-in)**.

Position back and connect the A/C compressor wire retainer.

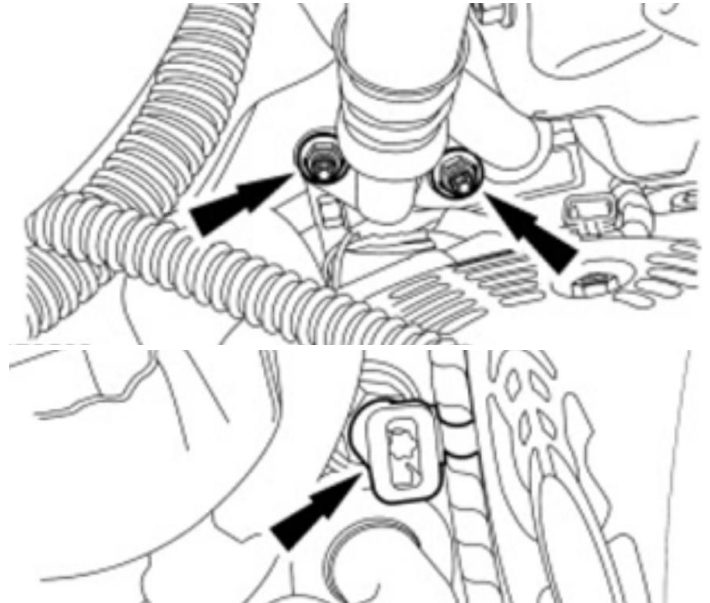

Position back the starter solenoid wiring. Install the 2 retaining nuts.

Tighten small nut to **12 Nm (106lb-in)**.

Tighten the large nut to **6 Nm (53lb-in)**.

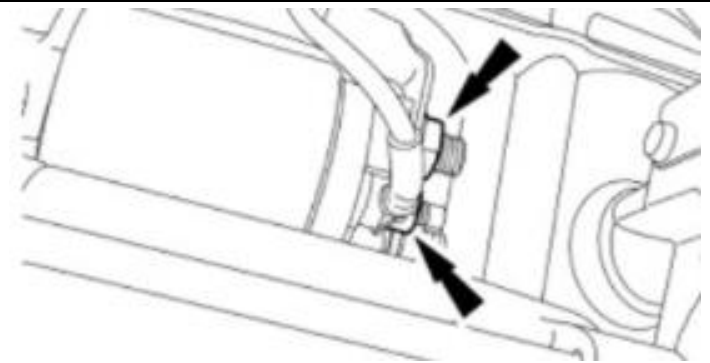

Install the cover for the starter terminals.



Position back the battery cable bracket and install the nut.

Tighten to **25 Nm (18lb-ft)**.

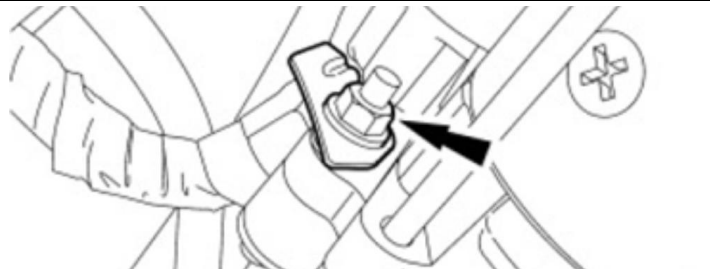

Position back the RH turbo charger inlet pipe. Install a gasket and the 3 RH turbo inlet pipe-to-exhaust manifold studs.

Tighten to **18 Nm (159lb-in)**.

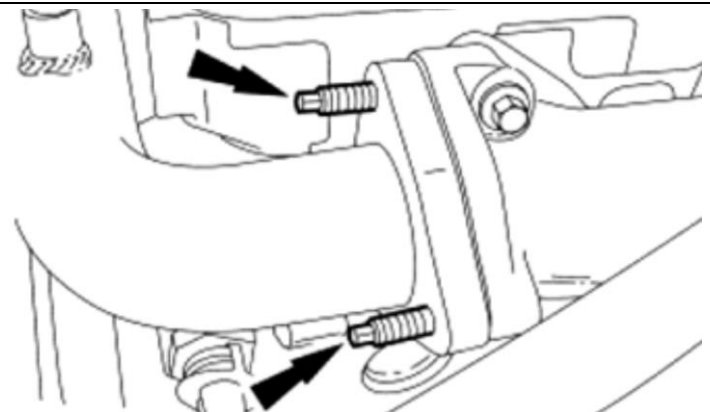

Install a turbo inlet pipe gasket and install the RH turbo inlet pipe-to-turbo bolts and inlet pipe-to-exhaust manifold nuts.

Tighten the top 2 bolts on the turbo end to **25 Nm (18lb-ft)**.

Use a half moon wrench for the bottom bolt. Refer to LH side procedure for steps/specification (**pg #10-11**).

Tighten the bottom 2 nuts on the exhaust manifold end to **31 Nm (23lb-ft)**.

Use a half moon wrench for the top nut. Refer to LH side procedure for steps/specifications (**pg #12-13**).

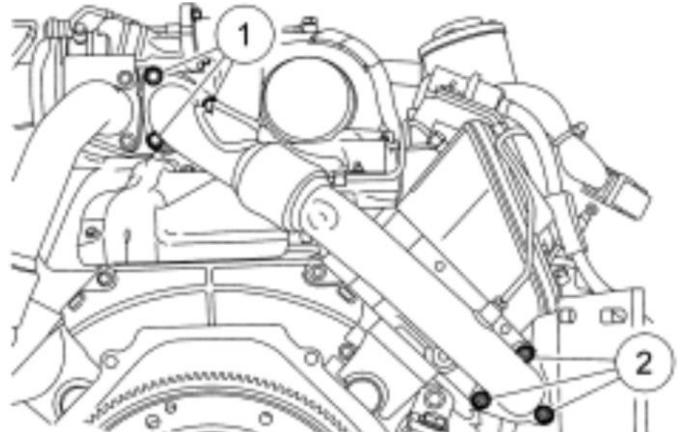

Position the EGR-OC pipe and loosely install the 2 bracket bolts. Install a gasket and loosely install the 2 bolts.

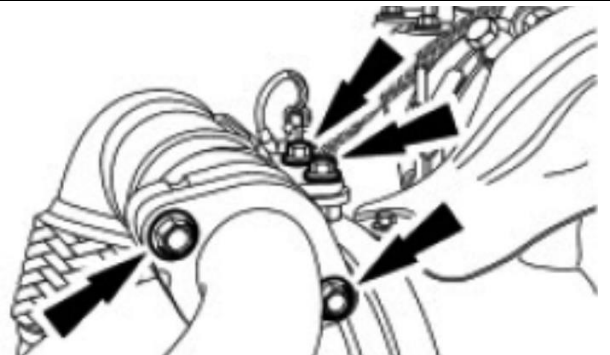

Install the EGT sensor into the RH turbo inlet pipe.

Tighten to **44 Nm (32lb-ft)**.

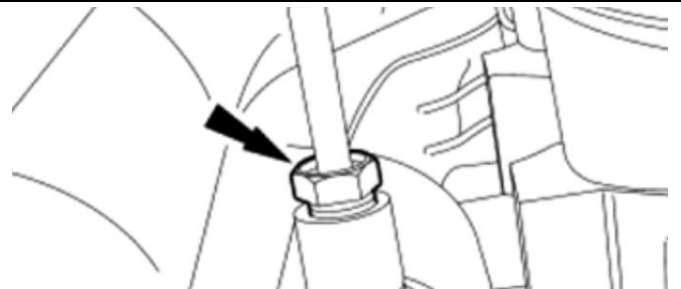

Install the front right wheel/tire, and the splash shield.

Install the bracket, washers and loosely install the 2 bolts for the EGR-OC pipe bracket.

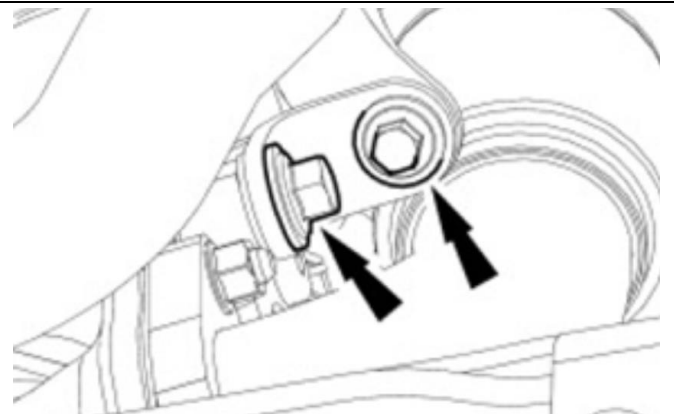

Install the gasket and the 2 bolts for the EGR cooler.

Tighten to **31 Nm (23lb-ft)**.



Tighten the 2 EGR-OC pipe bolts at the RH turbo inlet pipe.

Tighten to **31 Nm (23lb-ft)**.



Tighten the 2 bolts for the EGR-OC pipe bracket at the turbocharger.

Tighten to **31 Nm (23lb-ft)**.

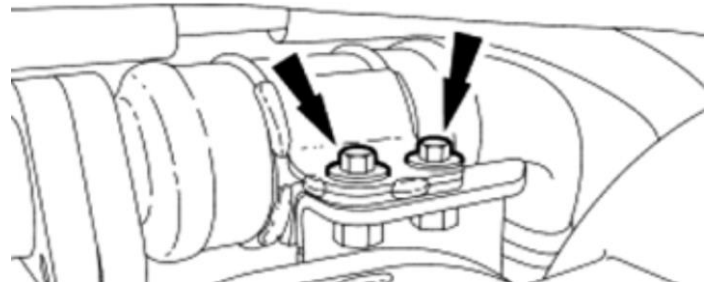

Install the gasket and loosely install the clamp for the exhaust downpipe.

Align the exhaust downpipe-to-turbo-clamp so that the exhaust downpipe clip and the opening in the exhaust downpipe-to-turbo clamp are aligned and tightened to maintain position.

Align the downpipe so that the area just above the flat in the pipe is approximately **20 mm (0.787 in)** from the frame.

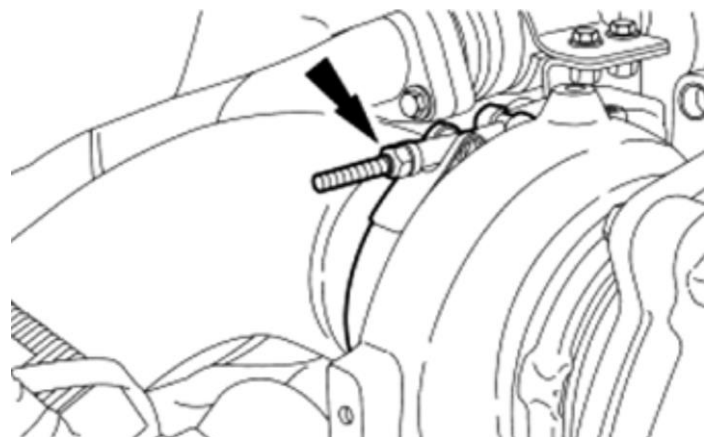

Tighten the bolt for the EGR-OC pipe bracket.

Tighten to **31 Nm (23lb-ft)**.

To tighten the second bolt for the EGR-OC pipe bracket a Half-moon wrench is required, refer to the next step.

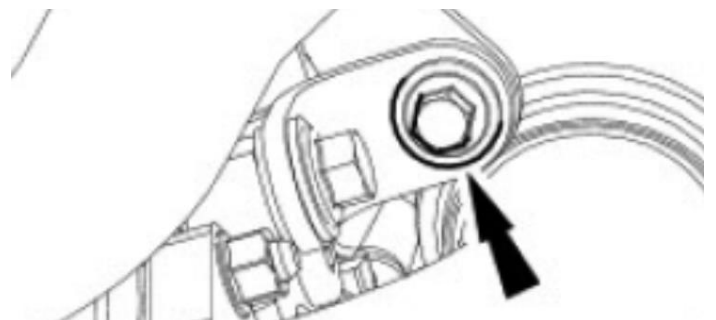

### EGR Pipe Bracket Bolt:

Due to limited access, one of the specific Half-moon wrenches and other tools described must be used to correctly tighten the fasteners in this step. Failure to follow this instruction may result in engine failure.

**Note:** To complete this step, it will be necessary to use the following tools:

- A 3/8-in drive torque wrench that is 368 mm (14.5 in) or 381 mm (15.0 in) from the center of the handle to the center of the square drive.
- One of the 11-mm/13-mm Half-moon wrenches listed in the following chart.
- A 11-mm Allen socket (to drive the Half-moon wrench).

**Note:** To obtain the required torque value of **63 Nm (46 ft-lbs)**, it will be crucial to orient the Half-moon wrench in the direction shown and 180 degrees (straight out) from the torque wrench.

Refer to the following chart for torque wrench setting, based on the specific Half-moon wrench and torque wrench length being used.

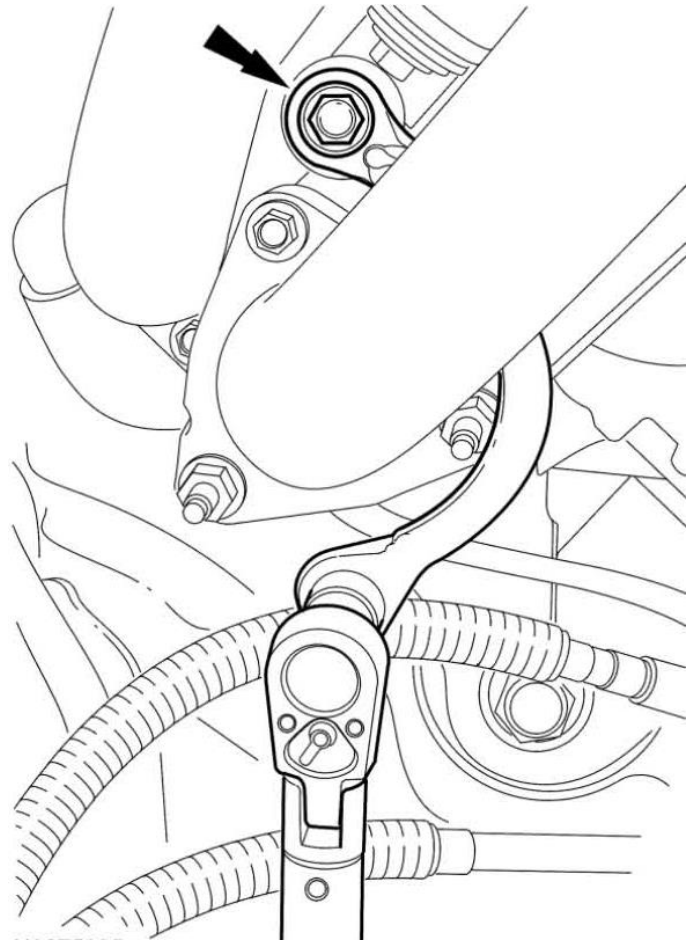

<i>Torque Chart – EGR Pipe Bracket Bolt</i>					
Half-Moon Wrench Brand	Wrench Part Number	Wrench Size	Torque Wrench Length	Torque Wrench Setting	
				Nm	lb-ft
Comwell®	BWM-1113MM	11/13 mm	14.5 in	47	35
Gear Wrench®	9852	11/13 mm	14.5 in	46	34
Matco®	MHM1113	11/13 mm	14.5 in	46	34
Mac®	HMM1113R	11/13 mm	14.5 in	46	34
Snap-On®	CXM1113	11/13 mm	14.5 in	46	34
Cornwell®	BWM-1113MM	11/13 mm	14.5 in	49	36
Gear Wrench®	9852	11/13 mm	14.5 in	47	35
Matco®	MHM1113	11/13 mm	14.5 in	47	35
Mac®	HMM1113R	11/13 mm	14.5 in	47	35
Snap-On®	CXM1113	11/13 mm	14.5 in	47	35
<b>NOTE:</b> To achieve the required torque of <b>62 Nm (46 lb-ft)</b> , the torque wrench must be set to the appropriate Torque Wrench Setting listed in this chart.					

Connect the EP sensor tube to the EGR-OC pipe.

Tighten to **20 Nm (177lb-ft)**.

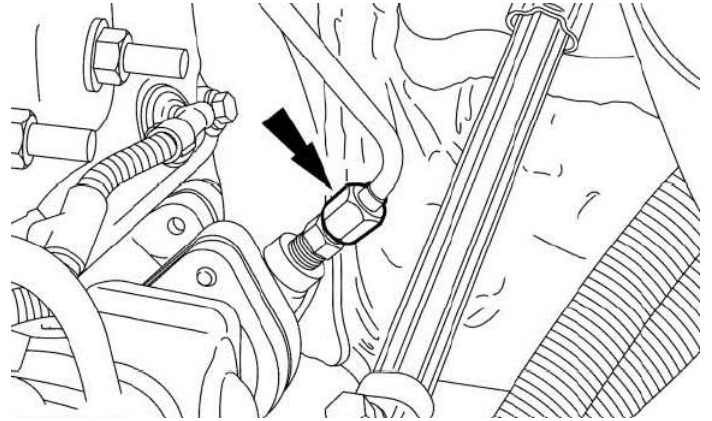

Install the 2 exhaust downpipe-to-OC pipe bolts.

Tighten to **40 Nm (30lb-ft)**.

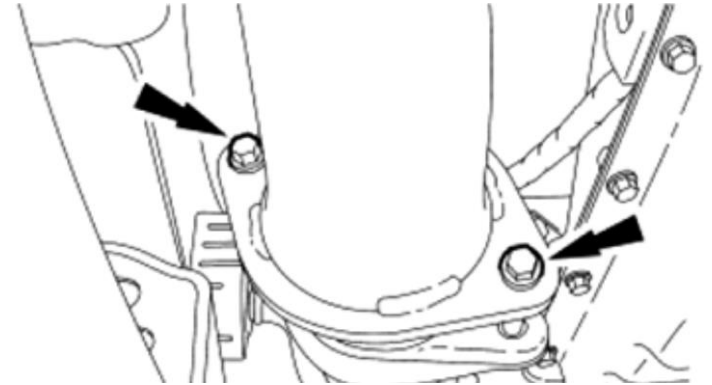

Tighten the clamp for the exhaust downpipe.

Tighten to **15 Nm (133lb-ft)**.

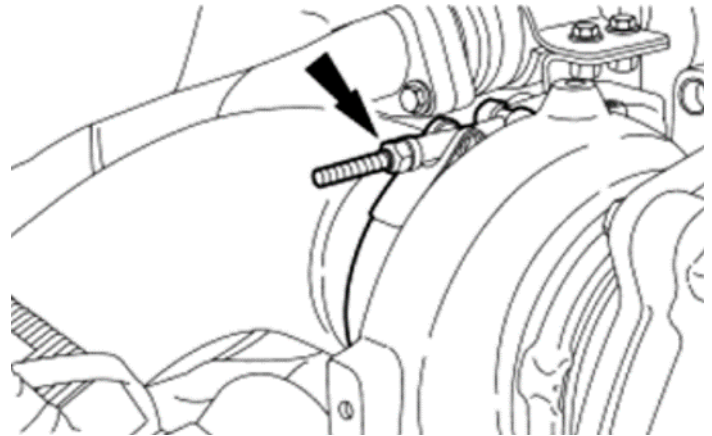

Connect both vehicle batteries.

**Vehicles with A/C:** Evacuate and charge the A/C system.  
**IMPORTANT!!!** Specialized equipment is required to do this procedure.

Position the auxiliary air intake hose in the vehicle.

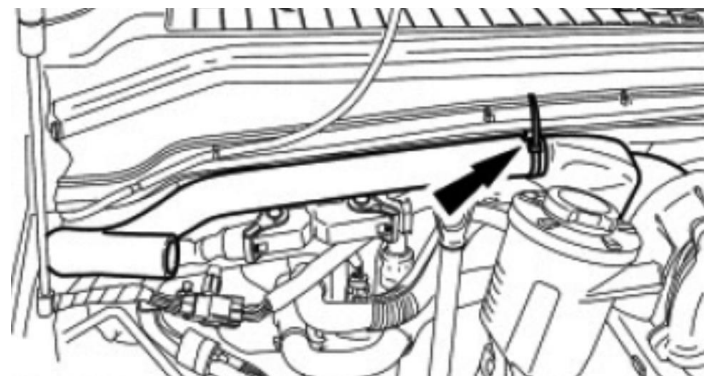

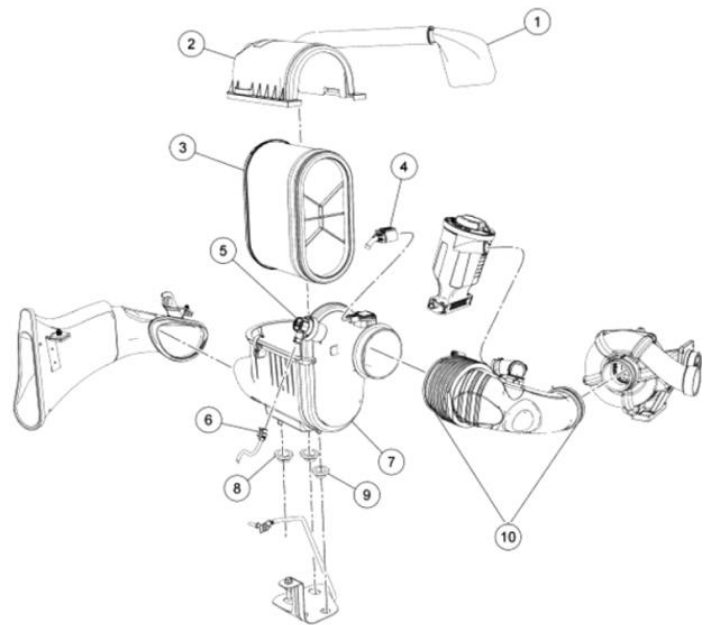

Install the ACL assembly.

- 1 – Secondary air intake
- 2 – Air Cleaner (ACL) outlet housing
- 3 – ACL Element
- 4 – Mass air flow (MAF) sensor electrical connector
- 5 – Restriction gauge
- 6 – Restriction gauge electrical connector
- 7 – ACL housing
- 8 – ACL housing isolator, oval (2)
- 9 – ACL housing isolator, round
- 10 – ACL outlet pipe

Fill the truck with coolant, reconnect both vehicle batteries, start up the vehicle and check for exhaust manifold leaks.



***DOWNLOAD COLOUR  
INSTALL MANUALS AT  
[www.bddiesel.com](http://www.bddiesel.com)***





**BD Diesel Ford Exhaust Up-Pipe Kit**  
**Install Instructions**  
2008 – 2010 Ford 6.4L Power Stroke F250-550

**1043909**



**Exhaust Up-Pipe Kit**

<b><i>Table of Contents</i></b>	
Table of Contents.....	2
Kit Contents .....	3
Optional Parts .....	3
Tools Required for Installation .....	4
Installation.....	4
Exhaust Up-Pipe.....	4
Removal .....	<b>4</b>
Installation of Driver side Up-Pipe .....	<b>7</b>
Installation of Passenger side Up-Pipe .....	<b>11</b>

## Kit Contents

1403130	1403133	B32256
		
<i>Up Pipe Passenger Side</i>	<i>Up Pipe Driver Side</i>	Gasket (Turbo Up-Pipe)
<b>Qty: 1</b>	<b>Qty: 1</b>	<b>Qty: 4</b>

FT-11116245	1900054	FT-11141221
		
<i>Bolt M8-1.25 x Flange CZP</i>	<i>EGR Flange Gasket</i>	Nut; M8-1.25 Top Lock
<b>Qty: 6</b>	<b>Qty: 1</b>	<b>Qty: 6</b>

## Optional Parts

Description	Part #
Turbo Up Pipe Gasket (4)	B32256
EGR Cooler Coolant Outlet Hose Clamp	8287
EGR Cooler Outlet Studs (2)	W302633
Horizontal EGR Cooler Outlet Nuts (2)	W300050
EGR Coolant Supply Tube Assembly O-Ring Seal	W301924
EGR Coolant Supply Tube Bolt	W300002
EGR Coolant Supply Tube Bolt	W300009
EGR Coolant Supply Tube Clamp	8287
Oil Level Indicator Tube O-Ring Seal	6754
Oil Level Indicator Tube Nut	W300050
Horizontal EGR Cooler Outlet Gasket	9H454
Manifold Bolts (8)	W302675
Horizontal EGR Cooler Bolts (4)	W302550
Manifold Stud Bolts (4)	W302647
Exhaust Manifold	1401482
Exhaust Manifold Gasket	MS19312
Exhaust Manifold Outlet Stud	FT-11508416

## Tools Required for Installation

- 10 - 16mm Socket & Wrench
- 7/16" , 9/16" Deep Socket
- Half-moon Wrench 10mm/12mm & 11mm/13mm
- 11 and 12mm Allen Sockets
- Pry Bar
- Torque Wrench
- Scraper
- Side Cutter

## Installation

Disconnect both vehicle batteries for safety.

### Exhaust Up-Pipe

#### Removal

Remove the two exhaust downpipe-to-oxidation catalytic converter (OC) pipe bolts.

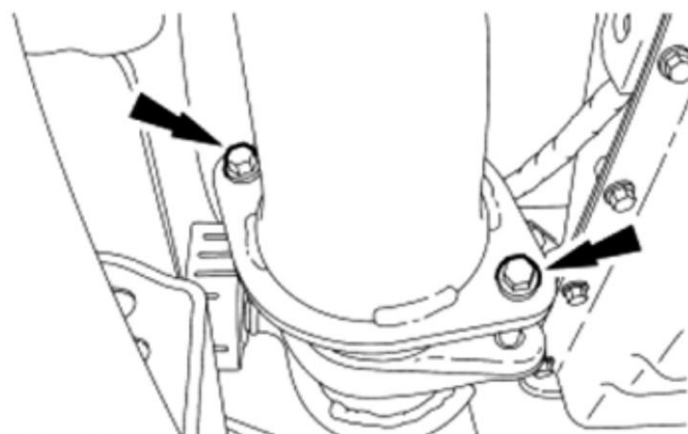

Remove the upper exhaust downpipe clamp. Position aside the exhaust downpipe. Remove the exhaust downpipe gasket.

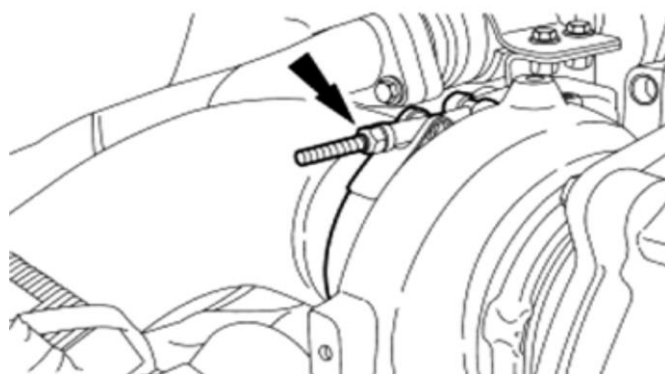

Disconnect the exhaust pressure (EP) sensor tube fitting.

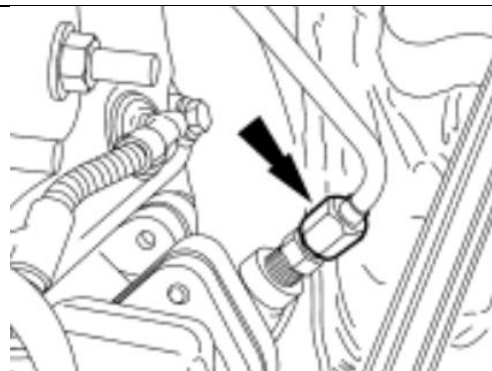

Remove the EGR-oxidation catalytic converter (OC) pipe bracket-to-cylinder head bracket bolt and washer. Remove the EGR-OC pipe bracket-to-LH cylinder head bolt, washer and the bracket.

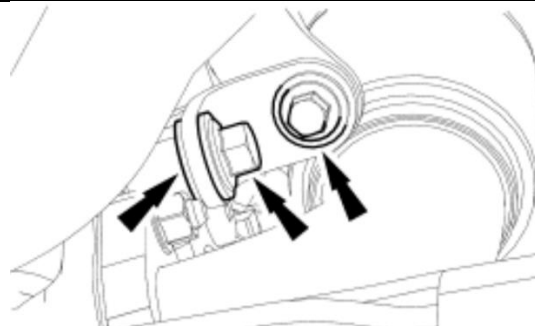

Remove the EGR-OC to EGR cooler bolts and position the EGR-OC pipe to the left side of the vehicle aside

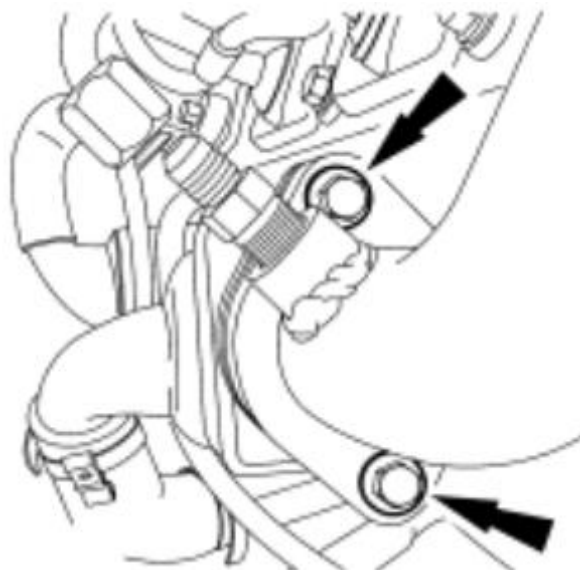

Remove the 2 EGR-OC pipe bolts and the 2 EGR-OC-to-turbo bracket bolts. Position the EGR-OC pipe aside

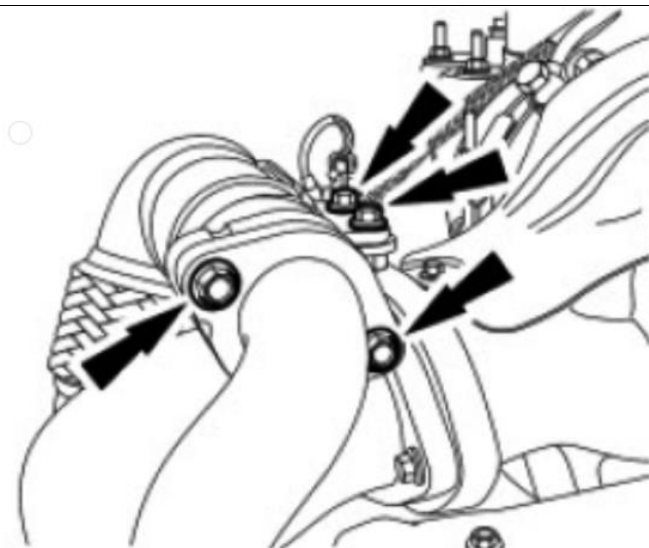

Remove exhaust gas temperature sensor from passenger side up-pipe and position aside.

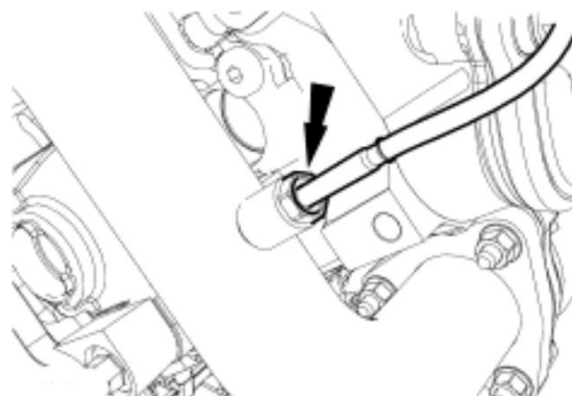

Remove three driver side up-pipe to turbo inlet port bolts (1) and the three up-pipe to exhaust manifold port nuts(2) and discard the driver side up pipe

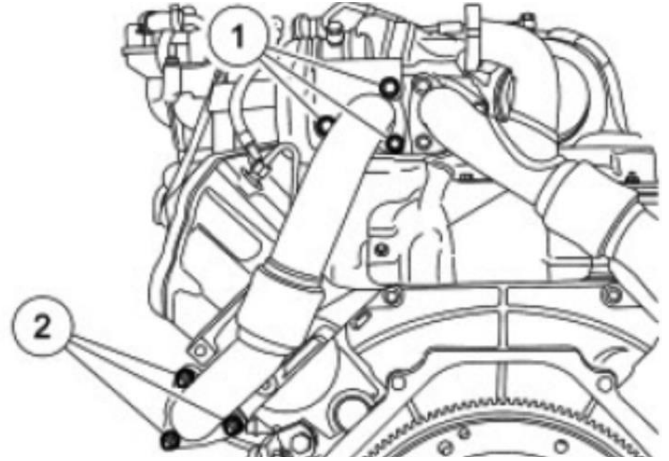

Remove three passenger side up-pipe to exhaust manifold port nuts.

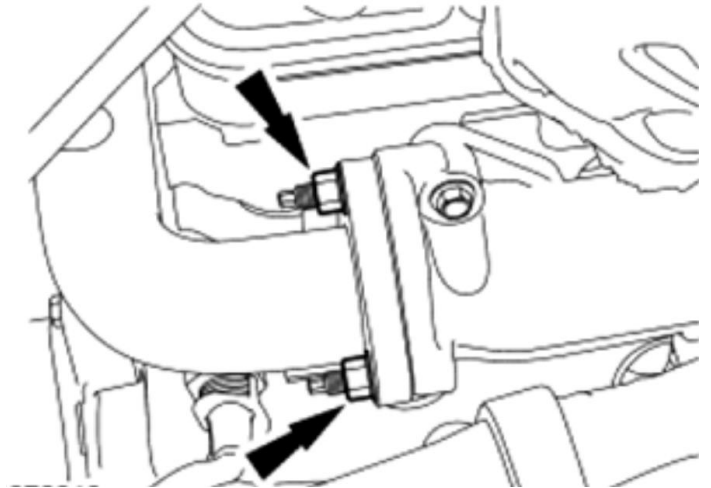

Remove three passenger side up-pipe bolts. Discard the passenger side up-pipe.

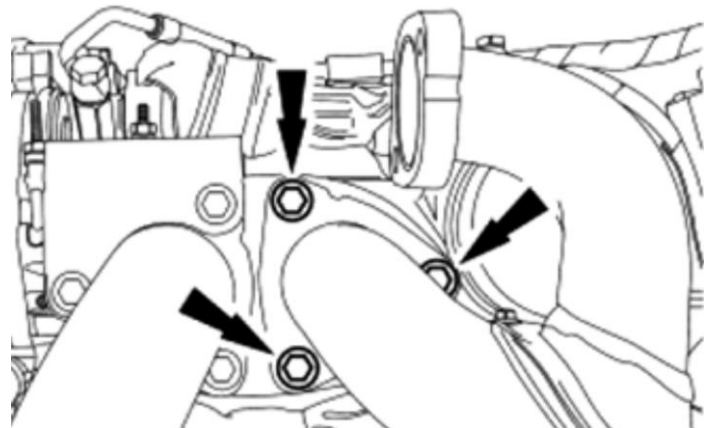

## Installation of Driver side Up-Pipe

Install the BD driver side up-pipe (1403133) to turbo inlet port using bolts(1) and to exhaust manifold outlet port using nuts(2).

- Tighten the top 2 bolts on the turbo inlet port to 24Nm (18lb-ft)
- Tighten the bottom 2 nuts on the exhaust manifold outlet port to 31Nm (23lb-ft)
- Refer to the next pages for the steps to tighten the remaining bolt and nut.

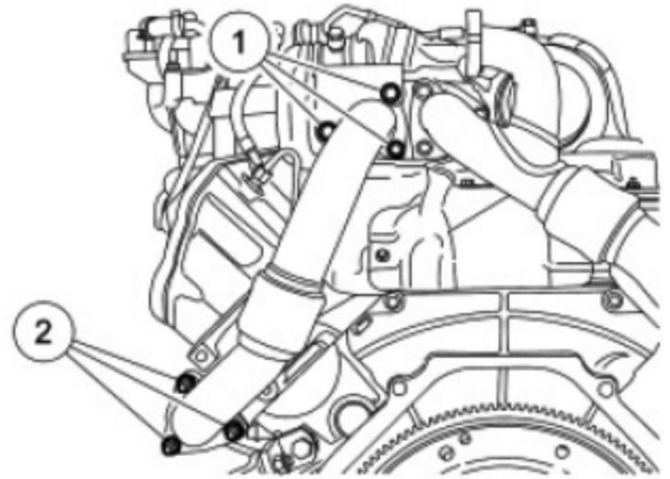

### Turbo Inlet Port Bottom Bolt:

Due to limited access, one of the specific Half-moon wrenches and other tools described must be used to correctly tighten the fasteners in this step. Failure to follow this instruction may result in engine failure.

**Note:** To complete this step, it will be necessary to use the following tools:

- A 3/8-in drive torque wrench that is 241 mm (9.5 in) or 368 mm (14.5 in) from center of the handle to the center of the square drive.
- One of the 10-mm/12-mm Half-moon wrenches listed in the following chart.
- A 12-mm Allen socket (to drive the Half-moon wrench).

**Note:** To obtain the required torque value of 24 Nm (18 ft/lbs), it will be crucial to orient the Half-moon wrench in the direction shown and 180 degrees (Straight out) from the torque wrench. The torque wrench must be set to the value specified in the following chart for the Half-moon wrench and torque wrench length being used.

Tighten the turbocharger inlet pipe-to-turbocharger bottom bolt.

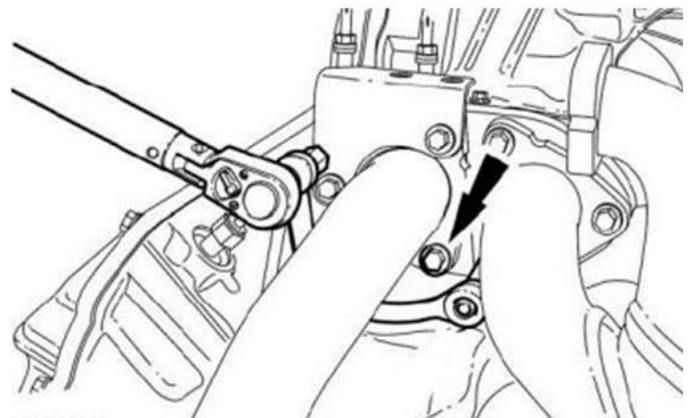

Refer to the following chart for torque wrench setting, based on the specific Half-moon wrench and torque wrench length being used.

<i>Torque Chart - Turbocharger Inlet Pipe-to-Turbocharger, Bottom Bolt</i>					
Half-Moon Wrench Brand	Wrench Part Number	Wrench Size	Torque Wrench Length	Torque Wrench Setting	
				Nm	lb-in
Comwell®	BWM- 1012MM	10/12 mm	9.5 in	20	177
Gear Wrench®	9851	10/12 mm	9.5 in	18	159
Matco®	MHM1012	10/12 mm	9.5 in	18	159
Mac®	HMM1012R	10/12 mm	9.5 in	15	133
Snap-On®	CXM1012	10/12 mm	9.5 in	18	159
Cornwell®	BWM- 1012MM	10/12 mm	14.5 in	19	168
Gear Wrench®	9851	10/12 mm	14.5 in	18	159
Matco®	MHM1012	10/12 mm	14.5 in	18	159
Mac®	HMM1012R	10/12 mm	14.5 in	16	142
Snap-On®	CXM1012	10/12 mm	14.5 in	18	159
<b>NOTE:</b> To achieve the required torque of 25 Nm (18 lb-ft), the torque wrench must be set to the appropriate Torque Wrench Setting listed in this chart.					

### **Exhaust Manifold Outlet Port Top Nut:**

Due to limited access, one of the specific Half-moon wrenches and other tools described must be used to correctly tighten the fasteners in this step. Failure to follow this instruction may result in engine failure.

**Note:** To complete this step, it will be necessary to use the following tools:

- A 3/8-in drive torque wrench that is 368 mm (14.5 in) or 381 mm (15.0 in) from the center of the handle to the center of the square drive.
- One of the 11-mm/13-mm Half-moon wrenches listed in the following chart.
- A 11-mm Allen socket (to drive the Half-moon wrench).

**Note:** To obtain the required torque value of 31 Nm (23 ft/lbs), it will be crucial to orient the Half-moon wrench in the direction shown and 180 degrees (straight out) from the torque wrench. The torque wrench must be set to the value specified in the following chart for the Half-moon wrench and torque wrench length being used.

Tighten the driver side up-pipe (1403133) to exhaust manifold outlet port nut.

Refer to the following chart for torque wrench setting, based on the specific Half-moon wrench and torque wrench length being used.

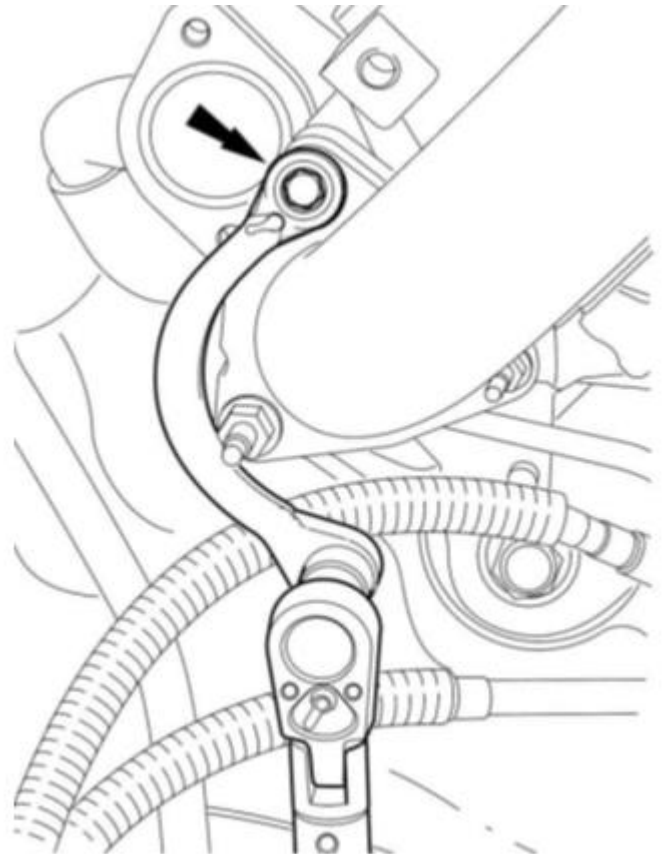

**Note:** Driver side shown, Passenger side is similar

<i>Torque Chart – EGR Pipe Bracket Bolt</i>					
Half-Moon Wrench Brand	Wrench Part Number	Wrench Size	Torque Wrench Length	Torque Wrench Setting	
				Nm	lb-ft
Comwell®	BWM-1113MM	11/13 mm	14.5 in	47	35
Gear Wrench®	9852	11/13 mm	14.5 in	46	34
Matco®	MHM1113	11/13 mm	14.5 in	46	34
Mac®	HMM1113R	11/13 mm	14.5 in	46	34
Snap-On®	CXM1113	11/13 mm	14.5 in	46	34
Cornwell®	BWM-1113MM	11/13 mm	14.5 in	49	36
Gear Wrench®	9852	11/13 mm	14.5 in	47	35
Matco®	MHM1113	11/13 mm	14.5 in	47	35
Mac®	HMM1113R	11/13 mm	14.5 in	47	35
Snap-On®	CXM1113	11/13 mm	14.5 in	47	35
<b>NOTE:</b> To achieve the required torque of 62 Nm (46 lb-ft), the torque wrench must be set to the appropriate Torque Wrench Setting listed in this chart.					

## Installation of Passenger side Up-Pipe

Place gasket (B32256) on exhaust manifold port stud then align and place passenger side up-pipe (1403130) on right side exhaust manifold outlet port stud as shown.

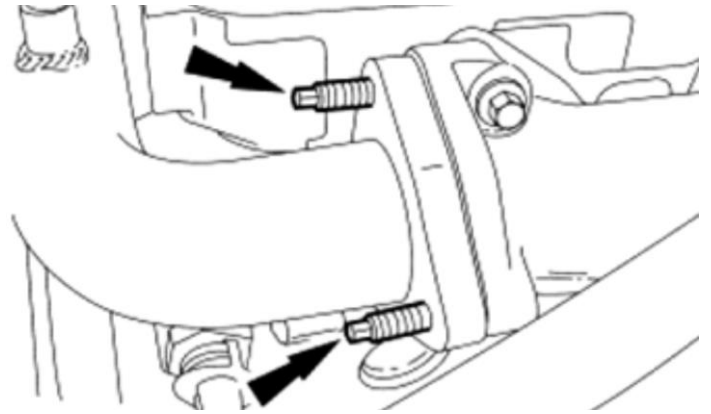

Place gasket(B32256) and install the passenger side up-pipe to turbo inlet port using bolts then put nuts on exhaust manifold port stud.

- Tighten the top 2 bolts on the turbo inlet port to 25Nm( 18lb-ft)
- Use a half moon wrench for the bottom bolt. Refer to driver side procedure for steps/specification.
- Tighten the bottom 2 nuts on the exhaust manifold end to 31Nm (23lb-ft)
- Use a half moon wrench for the top nut. Refer to driver side procedure for steps/specifications (pg # 9).

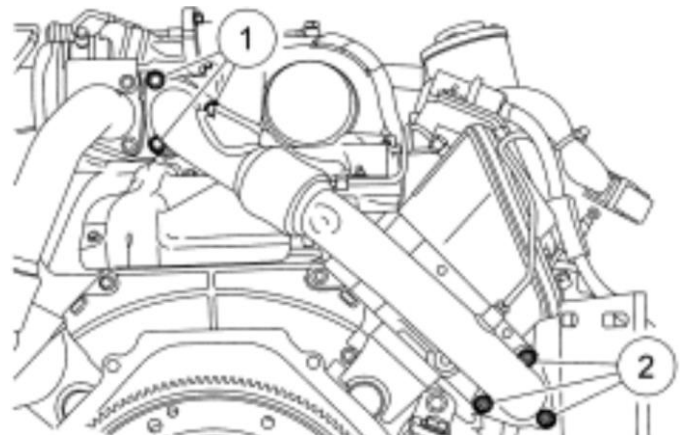

Position the EGR-OC pipe and loosely install the 2 bracket bolts. Install a gasket and loosely install the 2 bolts.

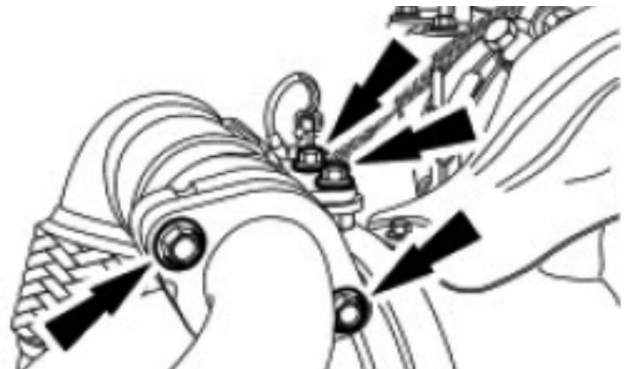

Install the EGT sensor into the RH turbo inlet pipe.

- Tighten to 44Nm (32lb-ft)

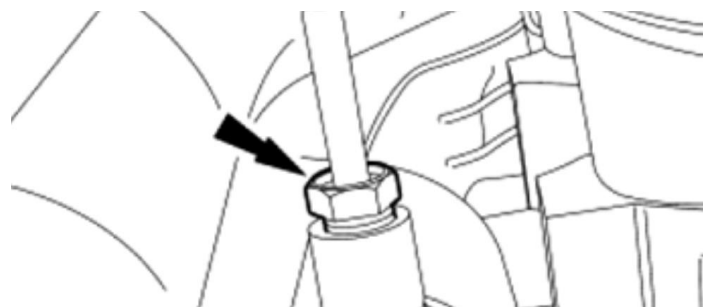

Install the bracket, washers and loosely install the 2 bolts for the EGR-OC pipe bracket.

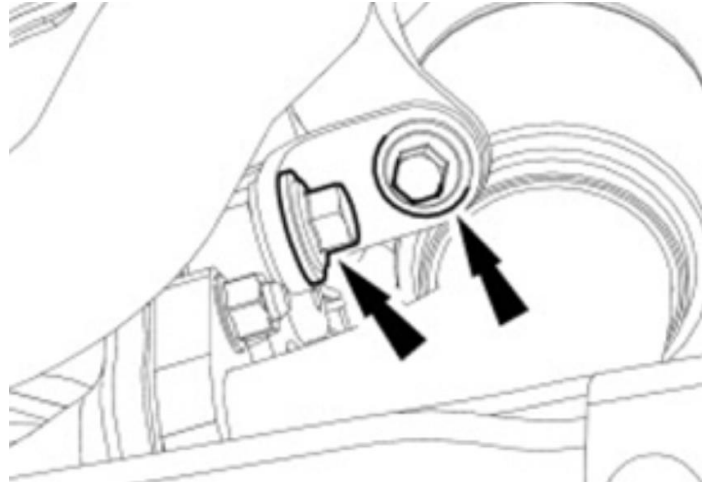

Install the gasket and the 2 bolts for the EGR cooler.

- Tighten to 31Nm (23lb-ft)



Tighten the 2 EGR-OC pipe bolts at the passenger side up-pipe EGR port.

- Tighten to 31Nm (23lb-ft)

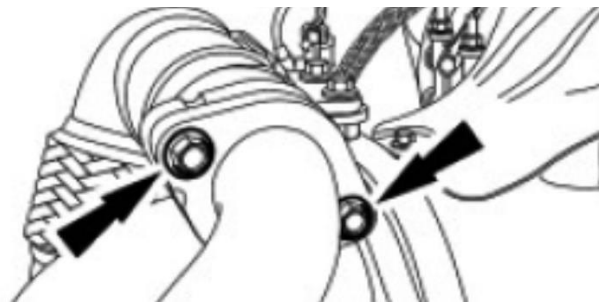

Tighten the 2 bolts for the EGR-OC pipe bracket at the turbocharger.

- Tighten to 31Nm (23lb-ft)

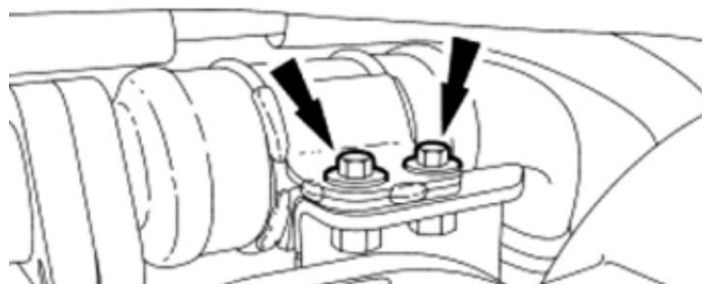

Install the gasket and loosely install the clamp for the exhaust downpipe. Align the exhaust downpipe-to-turbo-clamp so that the exhaust downpipe clip and the opening in the exhaust downpipe-to-turbo clamp are aligned and tightened to maintain position. Align the downpipe so that the area just above the flat in the pipe is approximately 20mm (0.787 in) from the frame.

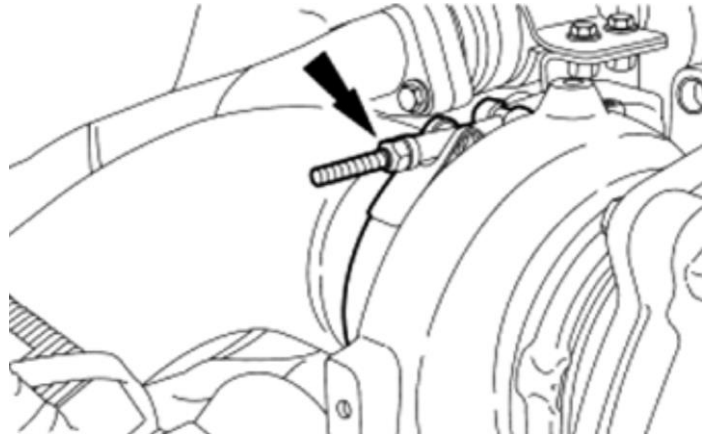

Tighten the bolt for the EGR-OC pipe bracket.

- Tighten to 31Nm (23lf-ft)

To tighten the second bolt for the EGR-OC pipe bracket a Half-moon wrench is required, refer to the next step.

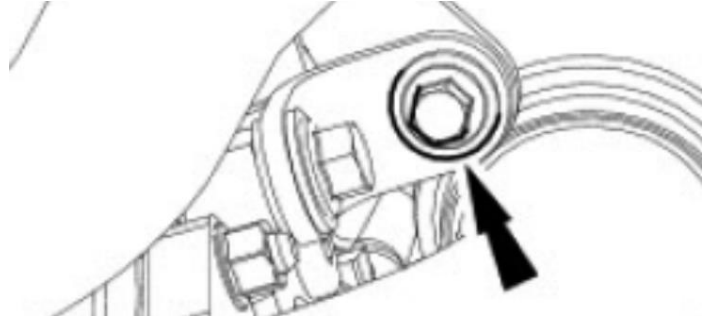

### ***EGR Pipe Bracket Bolt:***

Due to limited access, one of the specific Half-moon wrenches and other tools described must be used to correctly tighten the fasteners in this step. Failure to follow this instruction may result in engine failure.

**Note:** To complete this step, it will be necessary to use the following tools:

- A 3/8-in drive torque wrench that is 368 mm (14.5 in) or 381 mm (15.0 in) from the center of the handle to the center of the square drive.
- One of the 11-mm/13-mm Half-moon wrenches listed in the following chart.
- A 11-mm Allen socket (to drive the Half-moon wrench).

**Note:** To obtain the required torque value of 63 Nm (46 ft/lbs), it will be crucial to orient the Half-moon wrench in the direction shown and 180 degrees (straight out) from the torque wrench.

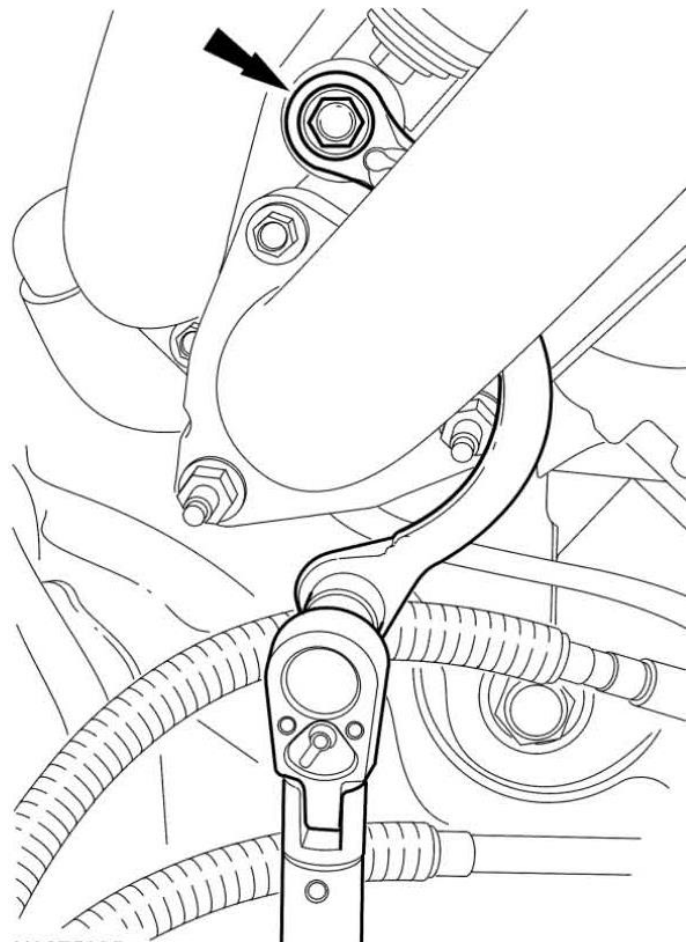

Refer to the following chart for torque wrench setting, based on the specific Half-moon wrench and torque wrench length being used.

<i>Torque Chart – EGR Pipe Bracket Bolt</i>					
Half-Moon Wrench Brand	Wrench Part Number	Wrench Size	Torque Wrench Length	Torque Wrench Setting	
				Nm	lb-ft
Comwell®	BWM-1113MM	11/13 mm	14.5 in	47	35
Gear Wrench®	9852	11/13 mm	14.5 in	46	34
Matco®	MHM1113	11/13 mm	14.5 in	46	34
Mac®	HMM1113R	11/13 mm	14.5 in	46	34
Snap-On®	CXM1113	11/13 mm	14.5 in	46	34
Cornwell®	BWM-1113MM	11/13 mm	14.5 in	49	36
Gear Wrench®	9852	11/13 mm	14.5 in	47	35
Matco®	MHM1113	11/13 mm	14.5 in	47	35
Mac®	HMM1113R	11/13 mm	14.5 in	47	35
Snap-On®	CXM1113	11/13 mm	14.5 in	47	35
<b>NOTE:</b> To achieve the required torque of 62 Nm (46 lb-ft), the torque wrench must be set to the appropriate Torque Wrench Setting listed in this chart.					

Connect the EP sensor tube to the EGR-OC pipe.

- Tighten to 20Nm (17lb-ft)

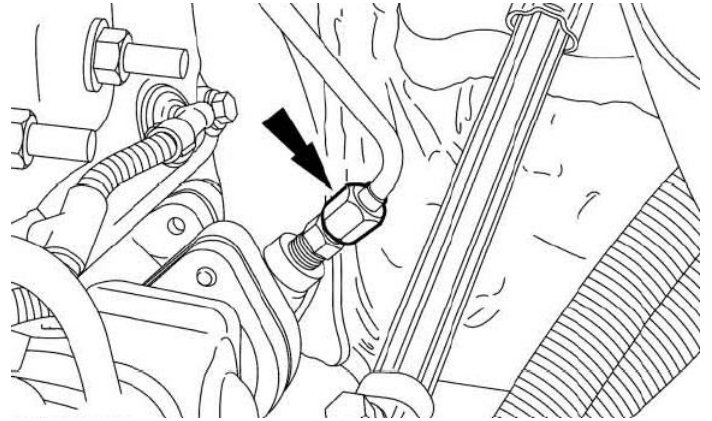

Tighten the clamp for the exhaust downpipe.

- Tighten to 15Nm (13lb-ft)

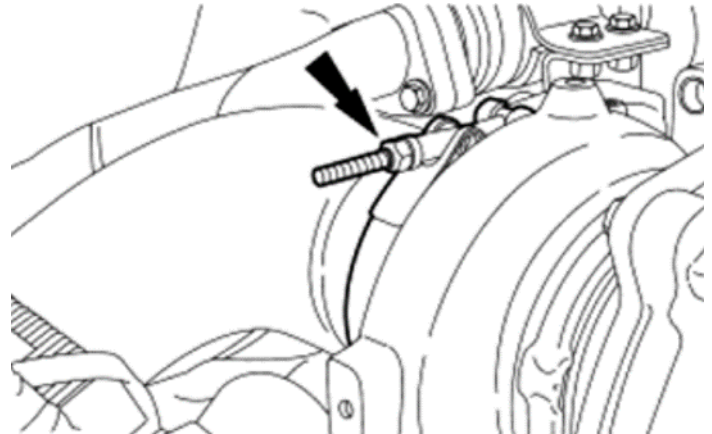

Install the 2 exhaust downpipe-to-OC pipe bolts.

- Tighten to 40Nm (30lb-ft)

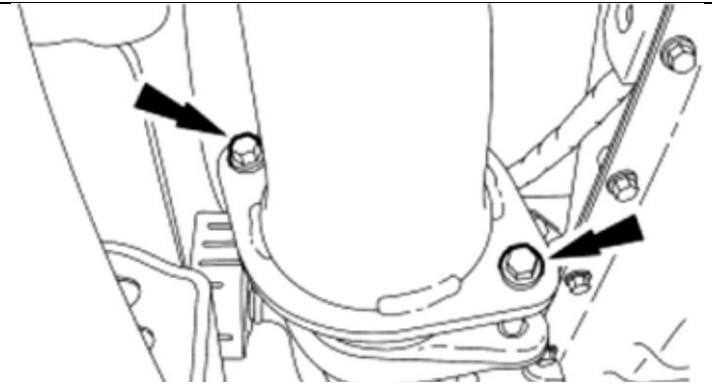

Reconnect both vehicle batteries start up the vehicle and check for exhaust leaks.