

(I-00300)

BD Engine Brake LIMITED WARRANTY STATEMENT

BD Engine Brake (the "Seller") warrants the following product(s):

All products manufactured or rebuilt by the Seller are to be free from defects in material or workmanship, which includes but is not limited to Turbochargers, Exhaust and Intake manifolds, Exhaust brakes, Intercoolers, Flex Plates, Transmissions, Torque Converters, Oil pans, Fuel pumps and systems, Electronic monitors and control systems. The Seller warrants to the original buyer of the product (the "Buyer") that it will repair or replace, free of charge, any product which has a defect in material or workmanship within the warranty period described below. Copy of original invoice is required to qualify for warranty.

A defect is defined as a condition within the product that would render the product inoperable under normal conditions of use and service. The Seller's responsibility under this Warranty is limited to the repair or replacement, at the Seller's option, of any warrantable product returned prepaid with complete service history and proof of purchase. A valid proof of purchase is a dated bill of sale or receipt.

A Return Material Authorization (RMA) number, obtained in advance from a customer service representative of the Seller and the dated bill of sale or receipt, must accompany any product returned by the Buyer for warranty determination. The Seller will be the final authority on the approval of all warranty claims hereunder. The issuance of a RMA number does not represent an approval of a warranty claim. BD reserves the right to return or replace Warranty Approved items freight Prepaid. While warranty denied or rejected, claims will be returned freight collect. Accepted warranty products, which have been replaced, will become the sole property of BD.

Until the Seller has approved a warranty claim, the Buyer will be responsible for all costs. Replacement parts and the labor costs incurred by the removal and replacement of the product while performing warranty work will be the responsibility of the Buyer. In no case does the obligation of the Seller exceed the original purchase price of the product as indicated on the original bill of sale or receipt. Under no circumstances will the Seller be liable for any travel time incurred in diagnosis for defects, or any other contingent expenses.

Only once the claim is approved, and depending on if the warrantable product is eligible, labor costs will be considered for the removal and replacement if an eligible part at an hourly rate of \$100.00 per hour. The end user may be responsible for the difference between the BD warranty labor rate and the authorized service dealer's labor rate. BD recommends the end user negotiate these conditions before the service is performed. As well the end user may be responsible for additional freight charges from FOB Abbotsford, BC / Washington.

To the extent permitted by law, the Buyer hereby waives all rights other than those expressly set out herein and acknowledges that this warranty sets out the Buyer's exclusive remedies with respect to products covered by it. This warranty shall not be extended, amended or varied except by written instrument signed by the Seller and the Buyer. If the buyer replaces the product from the Seller with another from another manufacturer, the Buyer-Seller warranty contract is void and the RMA Claim will be terminated. Any claim for remuneration will be rejected.

The Seller will administer warranty requests on products sold by the Seller and not manufactured by the Seller by forwarding claims made by a Buyer under the manufacturer's warranty to the manufacturer. The final disposition of such claims will be made by the manufacturer and ruled by the laws of British Columbia, Canada.

Customer assumes risk in purchasing product with in 30 days may return the product for exchange of other BD products or services only. No cash refunds are available.

The installation of BD aftermarket parts may void the OE warranty. BD is not responsible for OE warranties or how they are administered. Residents of the U.S.A. can reference the Magnuson-Moss warranty act that protects the consumer on the installation of aftermarket parts, please research this act to base your decisions accordingly.

In the case the warranty is denied, BD at its discretion, may offer to refurbish (where applicable) the product at discounted rate for the end user.

Please refer to Warranty time limitation per product.

NOT COVERED UNDER THIS WARRANTY

This warranty is limited to the original purchaser of the product and is not transferable to subsequent owners. Specifically excluded from this warranty are failures of products caused by misuse, misapplication, negligence of the Buyer, accidents, modification, abuse, improper storage, installation, repair or operation, use of unauthorized parts or other mistreatment of the Buyer or his agent. Any competitive use, sled pulling, drag racing will void warranty on product. A sheared or twisted shaft, broken planetary gear sets, burned clutches, broken drive hubs, sun gear damage, cracked housings are not covered. Damage caused from debris in oil contaminated coolers, improper fluids and filters or damage caused from fuel or air contamination, Biodiesel, low fluid levels are also not covered. This warranty does not cover deterioration of plating, paint or any other coating, linings or parts that are subject to normal wear and tear, such as light bulbs, fuses, bearing wear, seal wear, etc.

In the case of BD transmissions, a BD torque convertor must be installed at the time of installation of the transmission. Use of a 3rd party or OE convertor may invalidate the transmission warranty.

If product is not installed by a trained and authorized BD dealer, installation facility must prove it is properly tooled and has certified training to have installed or to carry out repair of product.

The Seller also disclaims any liability for incidental or consequential damages including but not limited to, repair labor, rental vehicles, hotel cost or any other inconvenience cost. To the extent permitted by law, this warranty is in lieu of all other warranties or guarantees, either expressed or implied, included the implied warranties of merchantability and fitness for a particular purpose and shall not extend to any Buyer or to any person other than the original purchaser residing within the boundaries of the continental U.S. or Canada. As well the seller is not responsible or obligated to update previously manufactured parts that are currently under the above warranty.

NOTE THAT THIS GUARANTEE WILL BE VOID IF THE USER BREACHES THE CONDITIONS IN THE SECTION LABELED "NOT COVERED UNDER THIS WARRANTY" AND IS ONLY APPLICABLE ON THE PRODUCTS THE SELLER MANUFACTURES.

DISCLAIMER OF LIABILITY

Other than as expressly set forth herein, the Seller, together with its distributors, jobbers and dealers shall in no way be responsible for the product's proper use and service. In no event shall the Seller be liable for any special, incidental, indirect or consequential damages of any kind or nature, whether or not the Buyer was advised of the possibility of damage, arising or resulting from the use or performance of the product, and the Buyer hereby waives any and all such claims.

The Buyer acknowledges that he/she/it is not relying on the Seller's skill or judgment to select or furnish goods suitable for any particular purpose and that the Seller has no liability that will extend beyond the scope of the limited warranty contained herein, and the Buyer hereby waives all remedies or liabilities, expressed or implied, arising by operation of law or otherwise, (including, without limitation, any obligations of the Seller with respect to fitness for any particular purpose; merchantability; and special, incidental, indirect or consequential damages) or whether or not occasioned by the Seller's negligence.

The Seller disclaims any warranty and expressly disclaims any liability for personal injury or damages related to the Buyer's use of the product. The Buyer acknowledges and agrees that the disclaimer of any liability for personal injury is a material term for this Agreement and the Buyer agrees to indemnify the Seller and hold the Seller harmless from any claim related to the product and its use or performance. Under no circumstances will the Seller be liable for any damages, liabilities, costs or expenses incurred as a result of by reason of the use, performance or sale of the product, including without limitation, any damages, liabilities, costs or expenses incurred by reason of the Buyer's negligence related to those uses of the product as a result of the removal of the speed limiter.

The Seller assumes no liability regarding the improper installation or misapplication of the product. It is the installer's responsibility to check for proper installation, and, if in doubt, contact the manufacturer.

Limited Warranty Details			
Product Name	Parts (Months/Miles) ¹	Labor (Months/Miles) ^{1,2}	Notes
Torque Converters	36/ 150,000	12/12,000	No Race abuse covered
Transmissions (TowMaster & TorqueMaster)	36/ 150,000	12/ 24,000	No Race abuse or broken shafts covered. Remote filter required for inspection with a cooler flow rate in GPM at Oil/Air transmission cooler outlet. Freight provision allowed.
Transmissions (RoadMaster)	24/ 100,000	12/ 24,000	
Rebuild/Repair Transmission	12/ 24,000	12/ 24,000	Defined as "Cost of Repair" or repaired units that fall outside of the retail warranty period.
Race Transmissions	12/ 24,000	Not Eligible	
Valve / Accumulators Bodies	12/ 24,000	12/ 24,000	
Transmission Pans	36/ 150,000	Not Eligible	
Flex Plates	36/ 150,000	Not Eligible	
Injectors (Mechanical) & Injection Pumps	12/ 24,000	12/ 24,000	VP44/P7100 Race Pumps 90 days parts/No labor coverage
Performance Injector Nozzles (Common Rail)	Not Eligible	Not Eligible	
Common Rail Injectors	24 Months	Not Eligible	Manufacturing and material defects are only covered. Cracks caused by high fuel pressure are not covered. High Return flow not covered after 12 months on Performance Injectors. For No Hassle Eligibility, see https://us.bddiesel.com/pages/extended-warranty
	24 Months + No Hassle	Not Eligible	
Performance Tuners and Chips	Manufacturer ³	Not Eligible	
BD Electronic Modules (TSB, VVB, etc)	24/ 48,000	Not Eligible	
Intake / Exhaust Manifolds	36/ 75,000	Not Eligible	
Exhaust Up pipes	12/24,000	Not Eligible	Surface rust not eligible.
Exhaust Kits	Manufacturer ³	Manufacturer ³	
Hoses / Clamps	12/ 24,000	Not Eligible	
BD Xtruded Transmission Cooler	12/ 24,000	Not Eligible	
Manual Transmission Clutches	Manufacturer ³	Manufacturer ³	
Short Shifters	12/ 24,000	Not Eligible	
Engine / Head Stud kits	Manufacturer ³	Manufacturer ³	
Positive Air Shutoff / Electronic Positive Air Shutoff	24/ 24,000	Not Eligible	
Exhaust Brakes	24/ 24,000	12/ 24,000	
Gauges and Mounts	Manufacturer ³	Manufacturer ³	
Screamer Turbos	24 Months	Not Eligible	24 Month warranty effective for sales after 11/01/2024
Performance/OEM Turbos	12 Months	Not Eligible	
Remanufactured ISX Turbos	90 Days	Not Eligible	See I-00437 for more details. For 1045880, see OEM Turbos.
Auxiliary Fuel Pumps	12/ 12,000	Not Eligible	
BD FICM	12 Months	Not Eligible	
Fuel Control Plate/Pin (VE & P7100)	24 Months	Not Eligible	
Distributed Product (Not Manufactured by BD)	Manufacturer ³	Manufacturer ³	
Replacement Components	12 Months	Not Eligible	
Transmission Rebuild/Build It Kits	12 Months	Not Eligible	Material Defects Only
Steering & Suspension Parts (Track Bar, Caster kit, Steering Stabilizer, Bars and links)	Limited Lifetime (12 months if not registered)	Not Eligible	Must register online within 30 days of purchase to be eligible. See website https://warranty.bddiesel.com/limited-lifetime/ for details. Excludes normal wear & tear (boots, bushings, joints, bearings) and improper use.
Venom/FlowMAX Fuel Lift Pump Kit	Limited Lifetime (12 months if not registered)	Not Eligible	Must register online within 30 days of purchase to be eligible. See website https://warranty.bddiesel.com/limited-lifetime/ for details. Excludes normal wear/service items (hose, filters) and improper use.

A Return Material Authorization (RMA) number, obtained in advance from a customer service representative of the Seller and the dated bill of sale or receipt, must accompany any product returned by the buyer for warranty determination.

¹ Warranty is based on whichever occurs first (Months or Mileage).

² Prior approvals must be given to qualify for labor reimbursement.

³ As per Manufacturer's warranty

Updated 10/21/2024



General Policy

All core returns must be,

- like for like, no mixed models
- drained of all fluids (\$50 Charge)
- be returned in the original packaging
- Part Disassembled
- No junkyard cores (core must have been removed from vehicle)
- No fire damage
- Free of excessive Rust or Water Damage

Returned cores that fail to follow the above conditions will be disallowed and scrapped or returned at the customer's expense. Freight and removal damage are not covered. BD Diesel reserves the right to adjudicate cores as it sees fit and may deviate from its policy.

BD FUEL INJECTION CORE ACCEPTANCE POLICY		
Model	Deduction	No Credit
P7100 Injection Pump	<ul style="list-style-type: none"> • AFC Housing Damaged (25% Deduction) • Governor Housing Damaged Front or Back (25% Deduction) 	<ul style="list-style-type: none"> • Contaminated/Bio Diesel • Damaged Camshaft on 911/913 pumps. • Main Body Damaged
Bosch VE Pump	<ul style="list-style-type: none"> • AFC Housing Damaged (25% Deduction) • Cold Advanced Housing Damaged (50% Deduction) • Governor housing damaged front or back (25% deduction) • Main Body Damaged (50% Deduction) 	<ul style="list-style-type: none"> • Contaminated/Bio Diesel • Seized Head (Does not turn)
CP3		<ul style="list-style-type: none"> • Contaminated/Bio Diesel • Seized (Does not turn) • Catastrophic Shaft Failure (Frost Plugs Damaged or Missing) • Front Cover Damaged
VP44	<ul style="list-style-type: none"> • Damaged Electronics (50% Deduction) 	<ul style="list-style-type: none"> • Contaminated/Bio Diesel • Seized Head (Does not turn)
Common Rail Injectors	<ul style="list-style-type: none"> • Solenoid melted or destroyed, stretched terminals (25% Deduction) • 5.9/6.7 Broken Solenoid Terminal Divider (No Deduction) 	<ul style="list-style-type: none"> • Contaminated/Bio Diesel • Damaged Body
Mechanical Injectors		<ul style="list-style-type: none"> • Contaminated/Bio Diesel • Damaged Body

BD TURBOCHARGER CORE ACCEPTANCE POLICY		
Turbo Model/ Application	Deduction	No Credit
Cummins ISX VGT Air or Electronic Actuated	<ul style="list-style-type: none"> • Damaged Electronics (50% Deduction) • Missing Clamps (25% Deduction) • Missing Parts or Actuators (50% Deduction) • Turbine Wheel Separation (50% Deduction) 	<ul style="list-style-type: none"> • Knock Off Models (Not Genuine) • Part Disassembled
Caterpillar (Ball Bearing) Models		<ul style="list-style-type: none"> • Knock Off Models (Not Genuine) • Wheel Separation
Caterpillar (Standard Turbocharger) 704604-9007, 704604-9011		<ul style="list-style-type: none"> • Knock Off Models (Not Genuine) • Turbo with 3 support Webs

Detroit Diesel VGT	<ul style="list-style-type: none"> • Damaged Electronics (50% Deduction) 	<ul style="list-style-type: none"> • Knock Off Models (Not Genuine) • Wheel Separation
Ford 6.4 Powerstroke	<ul style="list-style-type: none"> • Missing Parts or Actuators (50% Deduction) 	<ul style="list-style-type: none"> • Knock Off Models (Not Genuine) • Part disassembled • Wheel Separation
Ford 6.7 Powerstroke	<ul style="list-style-type: none"> • Missing Parts or Actuators (50% Deduction) 	<ul style="list-style-type: none"> • Wheel Separation
GM 6.6 L5P	<ul style="list-style-type: none"> • L5D Version (due to incorrect compressor cover) (25% Deduction) • Missing Parts or Actuators (50% Deduction) 	<ul style="list-style-type: none"> • Knock Off Models (Not Genuine) • Wheel Separation
Dodge Cummins 6.7 HE351VG/HE300VG	<ul style="list-style-type: none"> • Missing Parts or Actuators (50% Deduction) 	<ul style="list-style-type: none"> • Knock Off Models (Not Genuine)
Standard Turbochargers (All Models, Non VGT)	<ul style="list-style-type: none"> • Damaged Electronics (50% Deduction) • Missing Clamps (25% Deduction) • Missing Parts or Actuators (50% Deduction) 	<ul style="list-style-type: none"> • Knock Off Models (Not Genuine) • Wheel Separation

The above criteria apply to customer core returns. The following criteria will apply for core purchases.

Deduction	No Credit
<ul style="list-style-type: none"> • Cracked or Damaged due to freight • Damaged Electronics • Missing Parts or Actuators • Heavily Damaged Wheels and/or Shaft • Missing Clamps • Turbine Wheel Separation • Heavily Modified Turbochargers 	<ul style="list-style-type: none"> • Knock Off Models (Not Genuine)

BD TRANSMISSION/TORQUE CONVERTOR CORE ACCEPTANCE POLICY

Model	Deduction	No Credit
Transmissions	<ul style="list-style-type: none"> • Cracked Overdrive housings (\$100 Deduction) • 68rfe Cracked Case (25% Deduction) • Part disassembled (50% Deduction) • Missing Transmission Shipping Crate (\$200 Deduction) • Missing TC/Transmission bracket (\$50 Deduction) 	<ul style="list-style-type: none"> • Cracked Case (Except 68rfe)
Torque Convertors	<ul style="list-style-type: none"> • Hub and Impeller damaged. (50% Deduction) 	<ul style="list-style-type: none"> • Excessive corrosion • Part disassembled
Valve Bodies	<ul style="list-style-type: none"> • Missing electronics (25% Deduction) 	<ul style="list-style-type: none"> • Excessive corrosion • Part disassembled

GENERAL CORE ACCEPTANCE POLICY

Model	Deduction	No Credit
EGR Cooler		<ul style="list-style-type: none"> • Brackets broken

Please note that all cores have a time eligibility restriction. Please see BD Terms & Conditions for further details. https://cdn.bddiesel.com/downloads/bd_terms_general.pdf



TURBO AFTERMARKET Service Bulletin

New Retrofit Actuator for Ford V2S and HP Turbos

This bulletin outlines the introduction and service procedure of the new BorgWarner CBA (Compact Brushless Actuator) assembly, part number **59001107387**.

The original SRA (Smart Remote Actuator) Assembly, part number **476840** for the Ford 6.4 liter Powerstroke V2S turbo systems sold between 2008 and 2010 has been discontinued. The new retrofit actuator that fits into the same packaging and is identical in performance as the original actuator.

Retrofit Actuator Assembly

The new Retrofit Actuator Assembly consists of a BorgWarner CBA (Compact Brushless Actuator) with linkage, new actuator bracket, thermal spacer and mounting hardware. Installation of the Retrofit Actuator Assembly to the turbo requires removal of the original SRA Assembly and the specific installation sequence listed below.

Original SRA Assembly Removal

See *Figure 1*

1. Remove M6 nut (1) and separate linkage (2) from dog-bone (3)
2. Disconnect two coolant hoses from SRA
3. Disconnect electrical connector from SRA
4. Remove three M8 bolts (4)
5. Remove SRA Assembly and thermal spacer (5) from turbocharger
6. Properly discard SRA Assembly and hardware

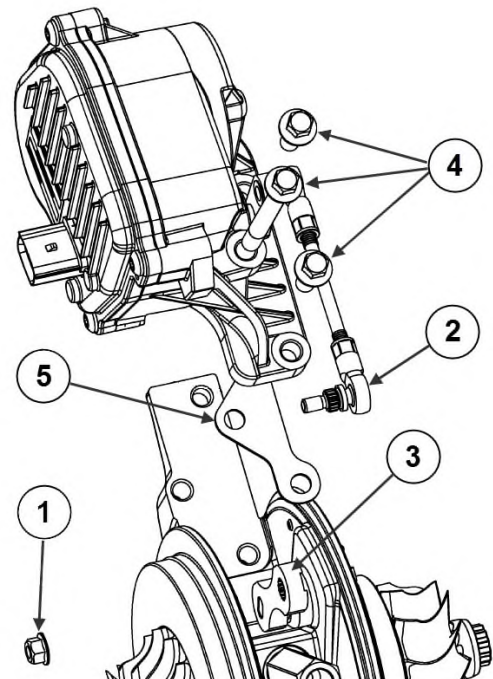

February 12, 2018 | S-02-18

Before installing the Retrofit Actuator Assembly:

1. Rotate the dog-bone by hand to ensure the VTG mechanism moves freely
2. Ensure the mounting surfaces and threads are clean and free of debris

Retrofit Actuator Assembly Installation

See Figure 2

1. Mount the thermal spacer (3) and Actuator bracket (2) to the turbocharger bearing housing using the supplied M8 bolts (1a,1b), ensuring proper orientation of thermal spacer. Torque the three M8 bolts to 19±1 Nm.
2. Insert Actuator linkage end into dog-bone (7) and loosely secure with M6 nut (6) by hand
3. Install Actuator assembly (4) to bracket (2) using the four supplied M6 bolts (5) and tighten to 13.5±1.1 Nm
4. Tighten M6 nut (6) to 10.5±0.3 Nm

Figure 2 - CBA

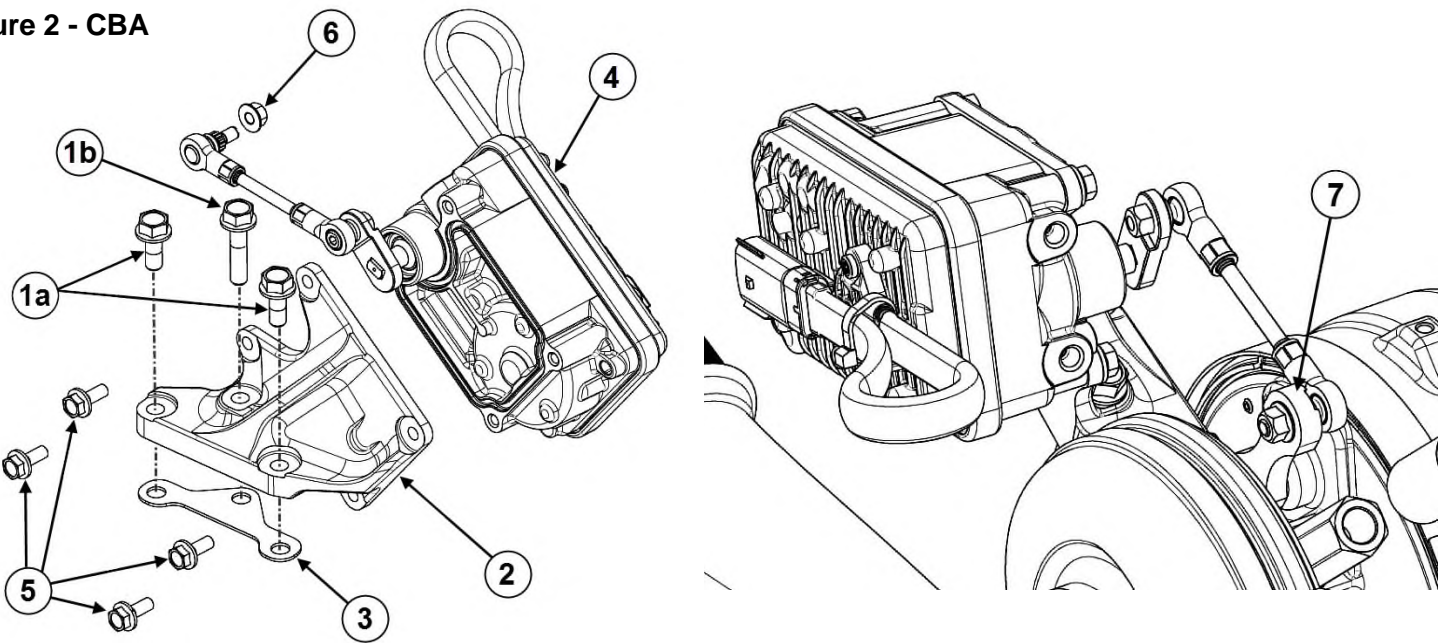

Item #	Description	Qty
1a	Flange Head Bolt - M8 x 20mm	2
1b	Flange Head Bolt - M8 x 35mm	1
2	Actuator bracket	1
3	Thermal spacer	1
4	Actuator assembly	1
5	Flange Head Bolt - M6 x 16	4
6	Nut - M6	1

Please refer to BorgWarner Turbo Aftermarket **Service Bulletin S-03-17** for the coolant line re-routing procedures.

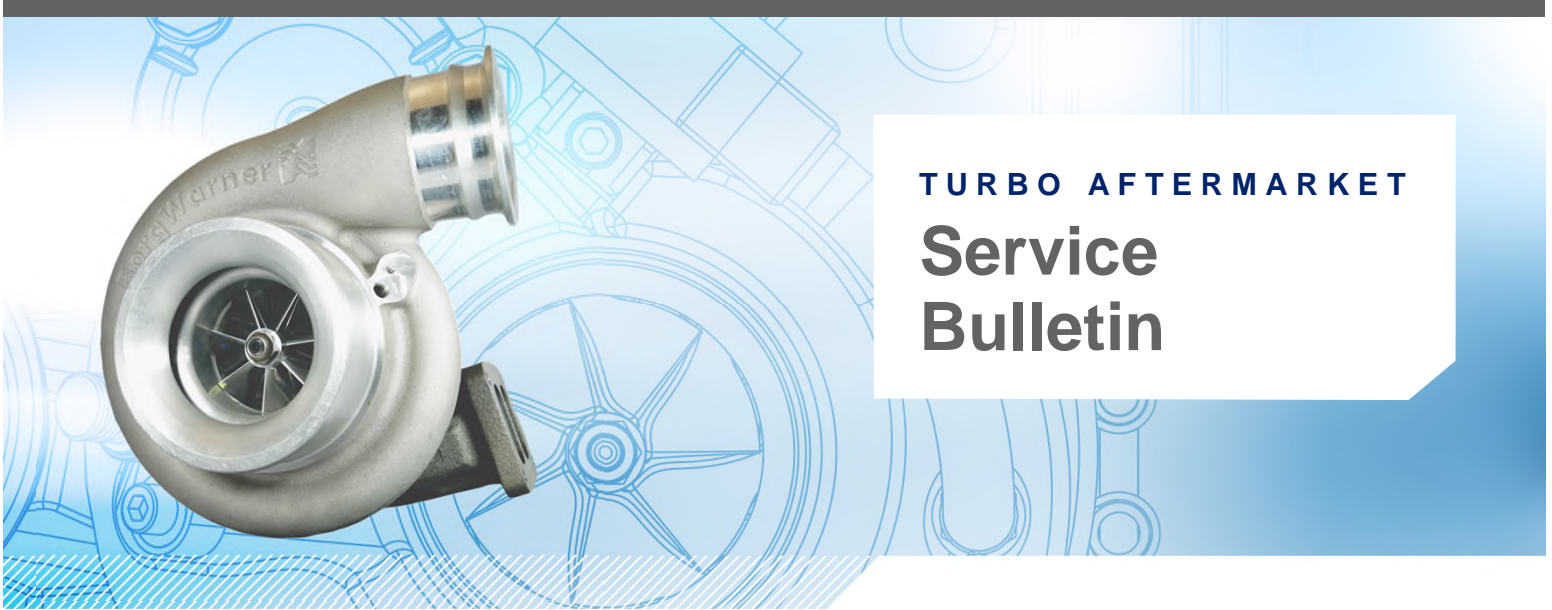

TURBO AFTERMARKET

Service Bulletin

6.4 liter V2S and HP stage Actuator Replacement

New retrofit Actuator

We are pleased to announce the release of the Ford 6.4 liter Powerstroke V2S turbo system with the BorgWarner retrofit actuator. This new actuator effectively replaces the original turbo Smart Remote Actuator (SRA). The BorgWarner Contact Brushless Actuator (CBA) fits into the same packaging profile and has the same performance characteristics as the original actuator which is no longer available.

Cooling Circuit

The new CBA retrofit actuator does not require water cooling as did the original SRA. The existing coolant lines can be rerouted to bypass the actuator and complete the cooling circuit without modification by eliminating the actuator coolant block and the short hose that went from the old actuator coolant block to the reservoir.



November 13, 2017 | S-03-17

Photo #1 below shows the original actuator and coolant line arrangement and Photo #2 shows the new actuator with the coolant line rerouted directly to the coolant reservoir.

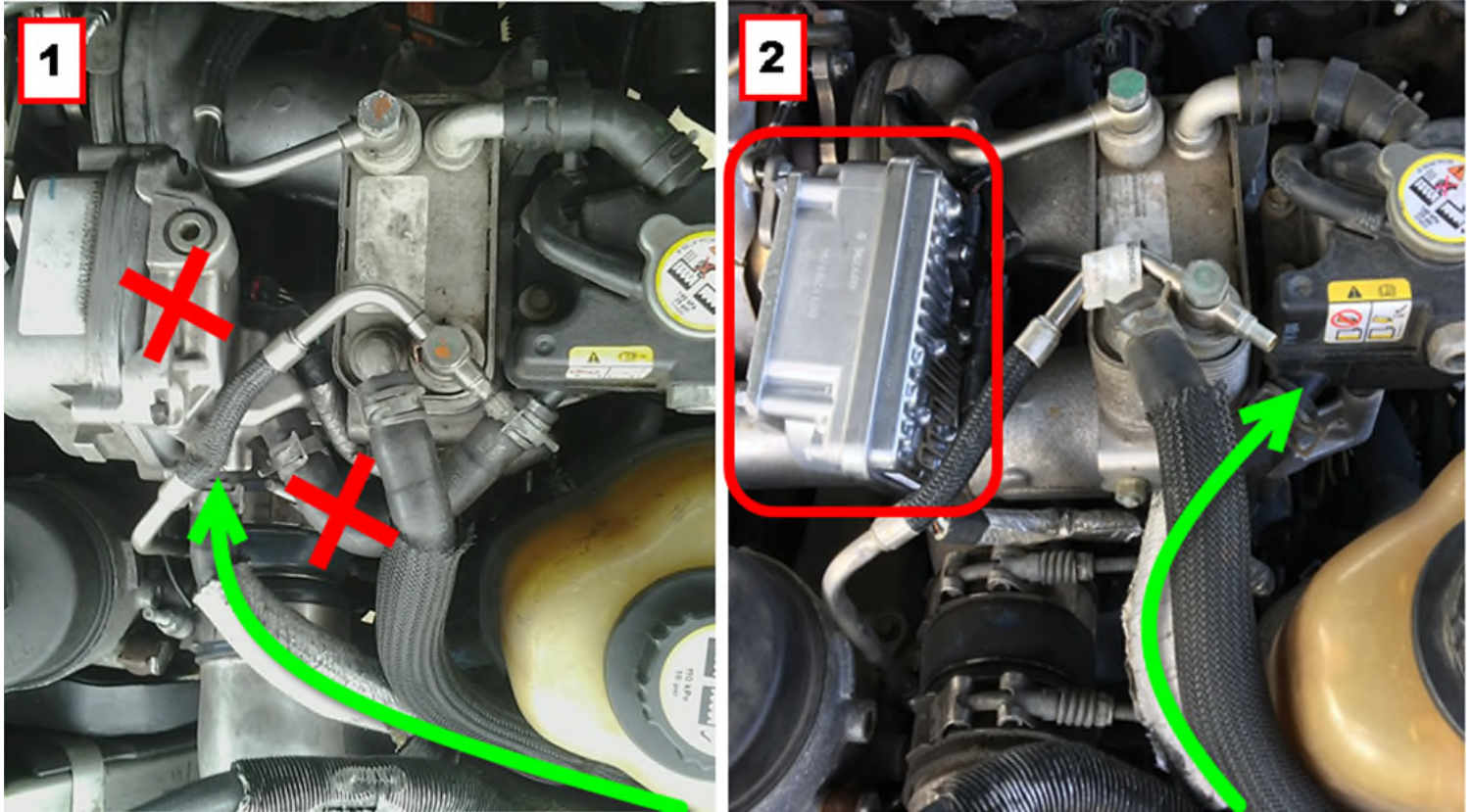

The coolant block attached to the original SRA actuator and the short hose connecting the coolant block to the reservoir will no longer be used. See red **X**'s in photo #1 above.

The shielded hose marked with the green  will move from the coolant block connection shown in photo #1 and go directly to the reservoir connection as shown in photo #2.

November 13, 2017 | S-03-17

Calibration

There is no external calibration procedure required for the new retrofit CBA actuator. The new actuator will automatically calibrate the first time it is powered up. Key on powers up the actuator and it moves to a safe position at 20% of full travel. It waits at this position for the ECU to provide information that will allow the actuator to execute a complete span sweep to learn its limits.

Contaminants in the engine oil

It is common for solid contaminants to build up in the 6.4 liter bearing systems. Not only in the turbo but in the oil cooler, and the oil lines and fittings supplying oil to the turbos. Please check the oil system to be sure it is free of solid contaminants before installing a new turbo system. These solid contaminants are carried to the turbo bearing system and deposited there causing premature bearing and turbo failure. Checking the system for debris before connecting the oil lines to the turbo will help protect your investment.

Final Assembly instructions

The orange plastic card is always removed. However we often see the two bolts left in the HP to LP turbine connection. These should also be removed once the V2S assembly is mounted to the engine.

