**STEP 5**

Tighten the mounting brackets to the vehicle. Adjust the running board to the desired angle, and tighten the bolts to secure the step into place. See photo for tightening order visual.

Repeat steps 1-5 for the remaining running board.  
Installation is now complete.

**TC4 HD RUNNING BOARDS**

- (2019-2025+ SILVERADO 1500 CREW CAB)
- (2020-2025+ SILVERADO 2500-3500 CREW CAB)
- (2019-2025+ SIERRA 1500 CREW CAB)
- (2020-2025+ SIERRA 2500-3500 CREW CAB)

**INSTALLATION INSTRUCTIONS****CONTENTS**

- (1) LH Running Board
- (1) RH Running Board
- (4) LH Step Brackets
- (4) RH Step Brackets
- (16) M8 x 30mm Hex Bolts
- (32) M8 x 24mm OD x 2mm Flat Washers
- (16) M8 Lock Washers
- (8) M8 x 25mm Combo Bolts
- (8) M8 x 25mm Hex Bolts
- (8) M8 Lock Nuts

**TOOLS REQUIRED**

- 13mm
- Sockets/Wrenches
- Ratchet

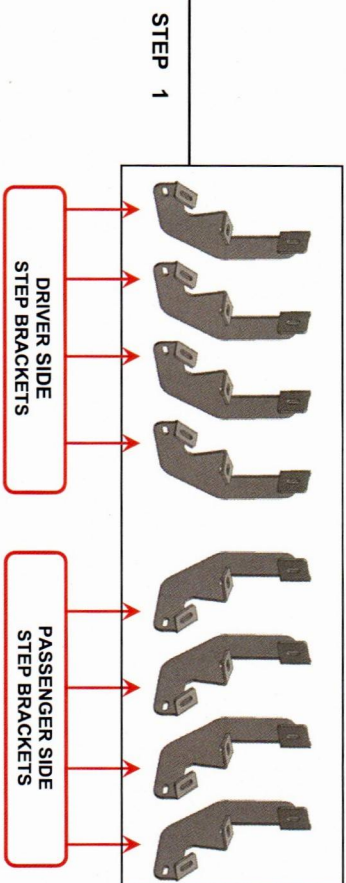

Please identify each mounting bracket using the engraved location identifier. **Notice:** The brackets can be used at any position along the same side of the vehicle.

DF: Driver Front  
DC: Driver Center  
DR: Driver Rear

PF: Passenger Front  
PC: Passenger Center  
PR: Passenger Rear

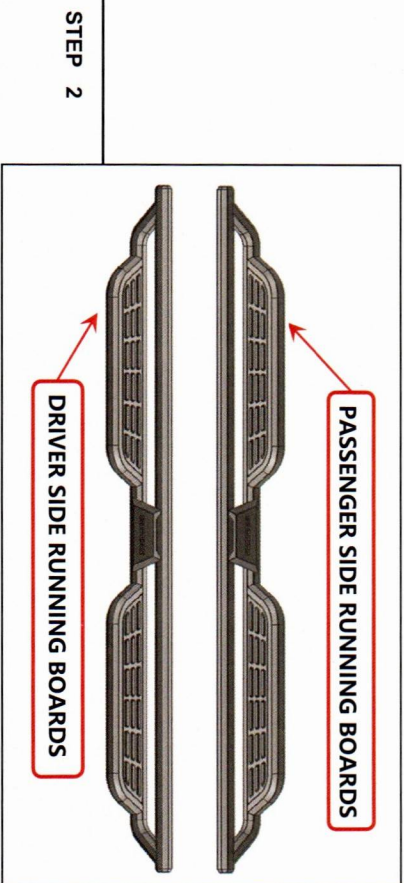

Identify each running board by identifier on the front. **Notice:** "D" for Driver/Left Side; "P" for Passenger/Right Side.

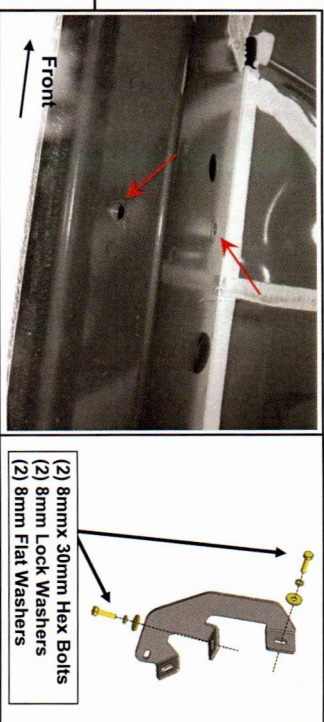

Start installation toward the front of the Passenger/Right side of the vehicle.

Loosely fit the (1) Passenger step bracket to the vehicle threaded body hole using (2) M8 x 30mm hex bolt, (2) M8 lock washer, and (2) M8 flat washer. Do not fully tighten to allow for later adjustments. Repeat this step for all step brackets.

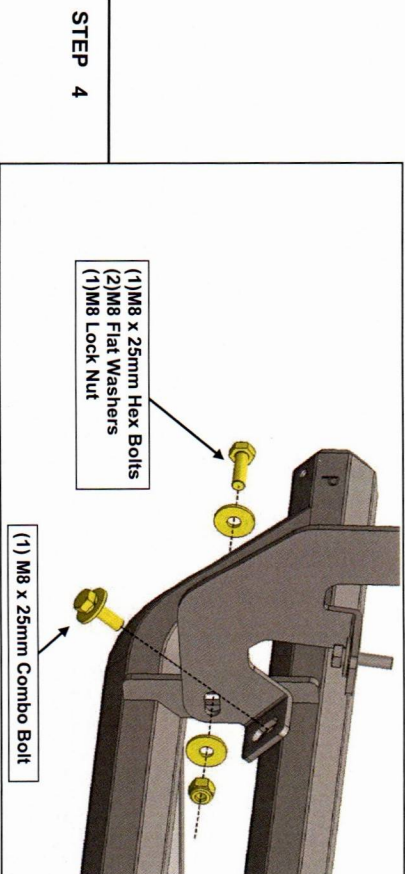

With all brackets loosely mounted to the vehicle, fit the running board onto the front bracket, and loosely secure into place using (1) M8 x 25mm combo bolt, (1) M8 x 25mm hex bolt, (2) M8 flat washer, (1) M8 lock nut. Repeat the step for other (3) PS step brackets.