



General Policy

All core returns must be,

- like for like, no mixed models
- drained of all fluids (\$50 Charge)
- be returned in the original packaging
- Part Disassembled
- No junkyard cores (core must have been removed from vehicle)
- No fire damage
- Free of excessive Rust or Water Damage

Returned cores that fail to follow the above conditions will be disallowed and scrapped or returned at the customer's expense. Freight and removal damage are not covered. BD Diesel reserves the right to adjudicate cores as it sees fit and may deviate from its policy.

BD FUEL INJECTION CORE ACCEPTANCE POLICY

Model	Deduction	No Credit
P7100 Injection Pump	<ul style="list-style-type: none"> • AFC Housing Damaged (25% Deduction) • Governor Housing Damaged Front or Back (25% Deduction) 	<ul style="list-style-type: none"> • Contaminated/Bio Diesel • Damaged Camshaft on 911/913 pumps. • Main Body Damaged
Bosch VE Pump	<ul style="list-style-type: none"> • AFC Housing Damaged (25% Deduction) • Cold Advanced Housing Damaged (50% Deduction) • Governor housing damaged front or back (25% deduction) • Main Body Damaged (50% Deduction) 	<ul style="list-style-type: none"> • Contaminated/Bio Diesel • Seized Head (Does not turn)
CP3		<ul style="list-style-type: none"> • Contaminated/Bio Diesel • Seized (Does not turn) • Catastrophic Shaft Failure (Frost Plugs Damaged or Missing) • Front Cover Damaged
VP44	<ul style="list-style-type: none"> • Damaged Electronics (50% Deduction) 	<ul style="list-style-type: none"> • Contaminated/Bio Diesel • Seized Head (Does not turn)
Common Rail Injectors	<ul style="list-style-type: none"> • Solenoid melted or destroyed, stretched terminals (25% Deduction) • 5.9/6.7 Broken Solenoid Terminal Divider (No Deduction) 	<ul style="list-style-type: none"> • Contaminated/Bio Diesel • Damaged Body
Mechanical Injectors		<ul style="list-style-type: none"> • Contaminated/Bio Diesel • Damaged Body

BD TURBOCHARGER CORE ACCEPTANCE POLICY

Turbo Model/ Application	Deduction	No Credit
Cummins ISX VGT Air or Electronic Actuated	<ul style="list-style-type: none"> • Damaged Electronics (50% Deduction) • Missing Clamps (25% Deduction) • Missing Parts or Actuators (50% Deduction) • Turbine Wheel Separation (50% Deduction) 	<ul style="list-style-type: none"> • Knock Off Models (Not Genuine) • Part Disassembled
Caterpillar (Ball Bearing) Models		<ul style="list-style-type: none"> • Knock Off Models (Not Genuine) • Wheel Separation
Caterpillar (Standard Turbocharger) 704604-9007, 704604-9011		<ul style="list-style-type: none"> • Knock Off Models (Not Genuine) • Turbo with 3 support Webs

Detroit Diesel VGT	<ul style="list-style-type: none"> • Damaged Electronics (50% Deduction) 	<ul style="list-style-type: none"> • Knock Off Models (Not Genuine) • Wheel Separation
Ford 6.4 Powerstroke	<ul style="list-style-type: none"> • Missing Parts or Actuators (50% Deduction) 	<ul style="list-style-type: none"> • Knock Off Models (Not Genuine) • Part disassembled • Wheel Separation
Ford 6.7 Powerstroke	<ul style="list-style-type: none"> • Missing Parts or Actuators (50% Deduction) 	<ul style="list-style-type: none"> • Wheel Separation
GM 6.6 L5P	<ul style="list-style-type: none"> • L5D Version (due to incorrect compressor cover) (25% Deduction) • Missing Parts or Actuators (50% Deduction) 	<ul style="list-style-type: none"> • Knock Off Models (Not Genuine) • Wheel Separation
Dodge Cummins 6.7 HE351VG/HE300VG	<ul style="list-style-type: none"> • Missing Parts or Actuators (50% Deduction) 	<ul style="list-style-type: none"> • Knock Off Models (Not Genuine)
Standard Turbochargers (All Models, Non VGT)	<ul style="list-style-type: none"> • Damaged Electronics (50% Deduction) • Missing Clamps (25% Deduction) • Missing Parts or Actuators (50% Deduction) 	<ul style="list-style-type: none"> • Knock Off Models (Not Genuine) • Wheel Separation

The above criteria apply to customer core returns. The following criteria will apply for core purchases.

Deduction	No Credit
<ul style="list-style-type: none"> • Cracked or Damaged due to freight • Damaged Electronics • Missing Parts or Actuators • Heavily Damaged Wheels and/or Shaft • Missing Clamps • Turbine Wheel Separation • Heavily Modified Turbochargers 	<ul style="list-style-type: none"> • Knock Off Models (Not Genuine)

BD TRANSMISSION/TORQUE CONVERTOR CORE ACCEPTANCE POLICY

Model	Deduction	No Credit
Transmissions	<ul style="list-style-type: none"> • Cracked Overdrive housings (\$100 Deduction) • 68rfe Cracked Case (25% Deduction) • Part disassembled (50% Deduction) • Missing Transmission Shipping Crate (\$200 Deduction) • Missing TC/Transmission bracket (\$50 Deduction) 	<ul style="list-style-type: none"> • Cracked Case (Except 68rfe)
Torque Convertors	<ul style="list-style-type: none"> • Hub and Impeller damaged. (50% Deduction) 	<ul style="list-style-type: none"> • Excessive corrosion • Part disassembled
Valve Bodies	<ul style="list-style-type: none"> • Missing electronics (25% Deduction) 	<ul style="list-style-type: none"> • Excessive corrosion • Part disassembled

GENERAL CORE ACCEPTANCE POLICY

Model	Deduction	No Credit
EGR Cooler		<ul style="list-style-type: none"> • Brackets broken

Please note that all cores have a time eligibility restriction. Please see BD Terms & Conditions for further details. https://cdn.bddiesel.com/downloads/bd_terms_general.pdf



**DOWNLOAD COLOUR
INSTALL MANUALS AT
www.bddiesel.com**



6.7L Cummins Performance Fuel Injectors

1715870	2007.5-2018	Performance (60HP)
1715871	2007.5-2018	Performance (90HP)
1715872	2007.5-2018	Performance (120HP)

Premium line injectors are built with new Bosch solenoids, nozzles and control valves

PLEASE READ ALL INSTRUCTIONS BEFORE INSTALLATION

Removal

1. Disconnect both vehicle batteries before installation for safety.

2. Remove cylinder head cover

Only 2013-2018 models

3. Disconnect both fuel injector harness connectors

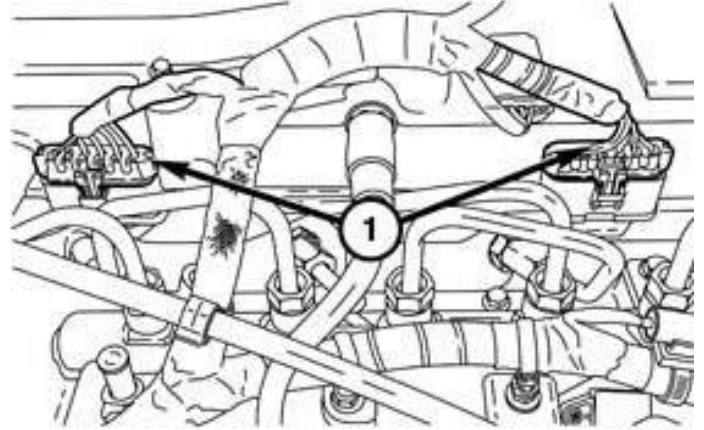

4. Remove all fuel injector wire harness nuts securing the integrated wiring harness to all fuel injectors.

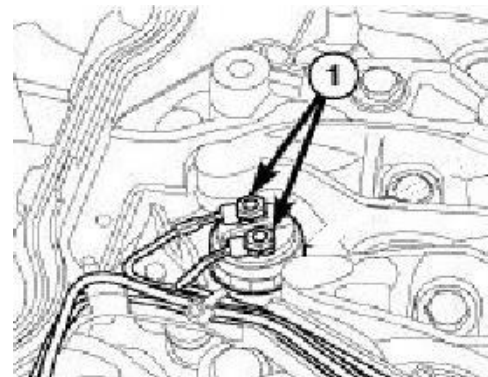

5. Remove the cylinder cover gasket.

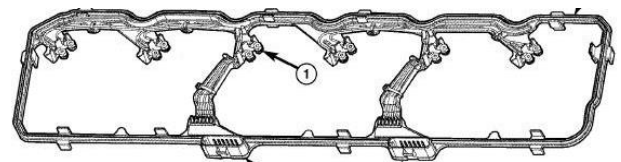

6. Remove the six high pressure fuel feed lines.

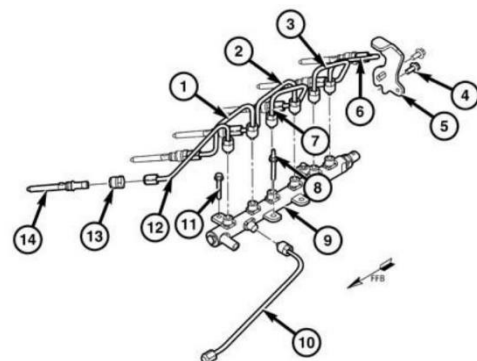

7. Remove the fuel injector connector nut.

Install the High Pressure Connector Remover onto the fuel injector connector tube located in cylinder head.

Use the High Pressure Connector Remover pry and remove the fuel injector connector tubes from the cylinder head.

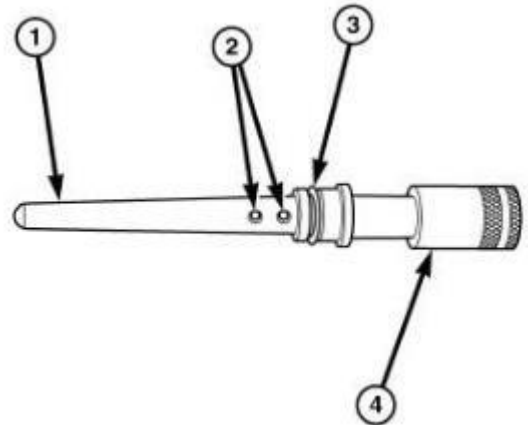

8. Slowly loosen the injector hold down clamp bolts.

Sequentially turn one bolt counterclockwise 1 rotation, then switch to the other bolt, repeat.

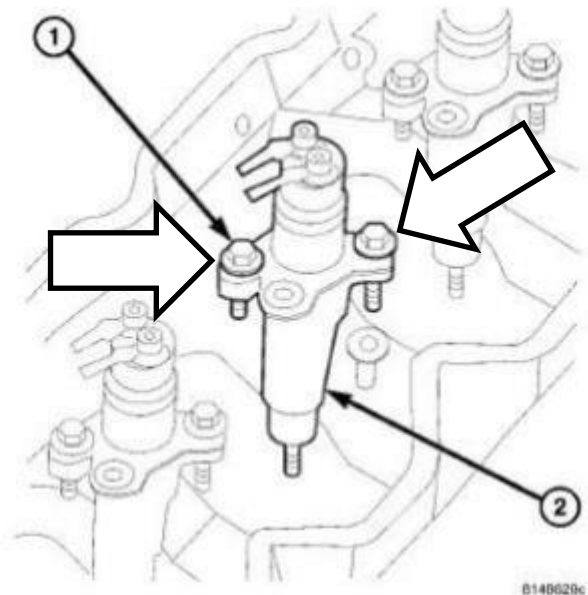

9. Remove the bolts, rocker arms, pedestals, and crossheads from the cylinder head.

Note: Mark each component so they can be installed in their original position.

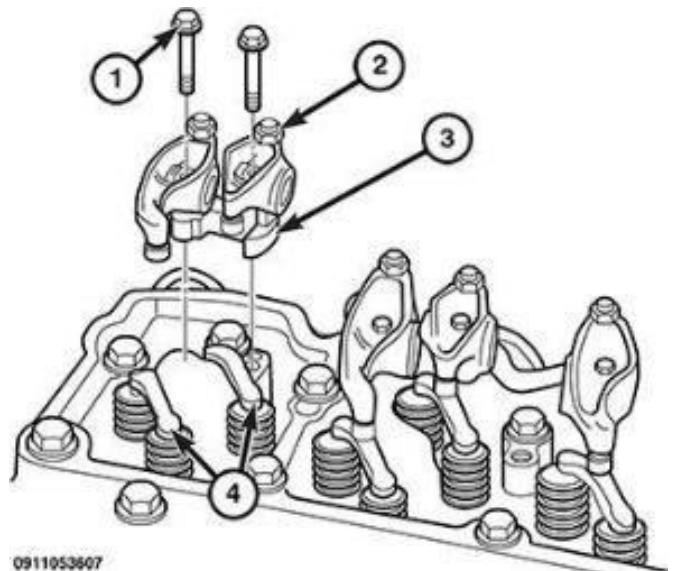

10. Ensure the fuel injector sealing washer has been removed and has not remained in the injector bore.

Discard the used seal, a new washer seal will need to be used.

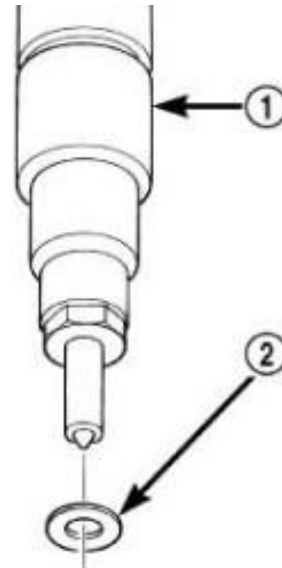

Installation

1. Measure the copper washer thickness, (.060"). Apply a light coating of clean engine oil to the washer to keep it in place during installation. Ensure the new copper sealing washer is installed on the injector.

Apply a small amount of clean engine oil to the O-ring and injector bore and then seat the injector into the cylinder head.

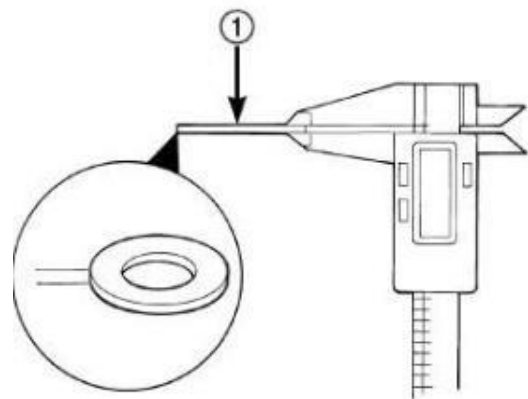

2. Follow the tightening sequence listed in steps a-f below. The connector tubes must be seated in the center of the injector and perpendicular to the injector to seal properly.

- a. Seat the fuel injector into the cylinder head.
- b. Ensure both bolts are threaded in evenly, preliminarily tighten down the two injector hold down bolts to 44 **in-lb**.
- c. Relieve bolt torque, but leave both bolts threaded in place.

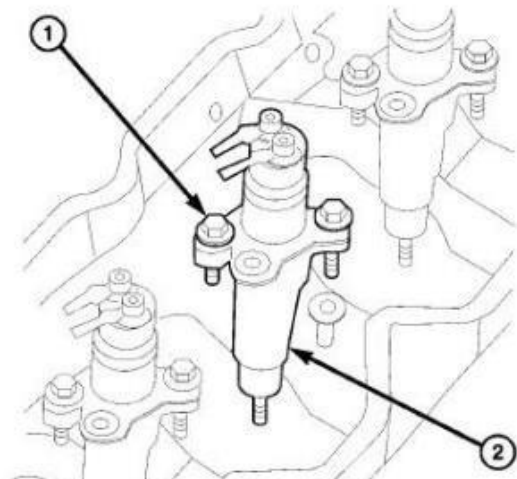

- d. By hand, thread in the fuel injector connector tubes to ensure the fuel injector is centered and perpendicular to the connector tube. You can gently rotate the injector until the connector tube is correctly positioned. Do a preliminary tightening of the connector tube nut to 133 **in-lb**.

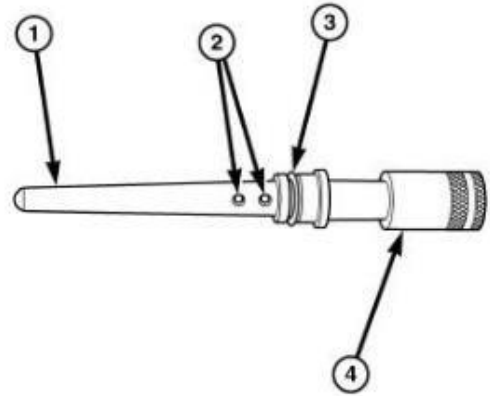

- e. Alternating tightening sequence, tighten the injector hold-down bolts to 71 **in-lb**.

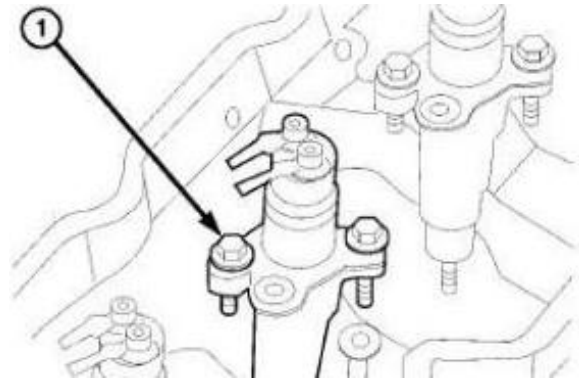

- f. Do a final tightening of the fuel injector tube nut.

Tighten to 41 **ft-lb**.

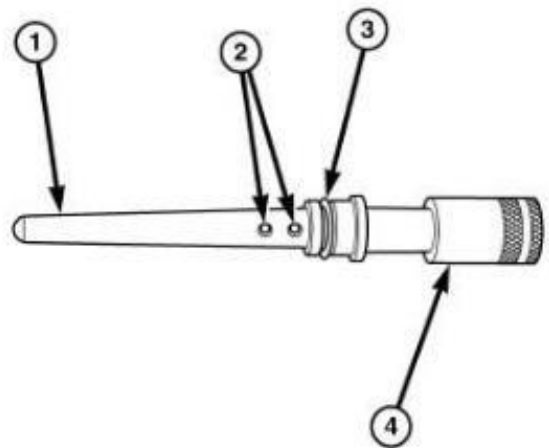

3. Install the correct fuel tubes to the correct injectors on the engine. Ensure each fuel line is free from debris and the sealing surfaces are in good condition.

Bracket (No. 5) must be loosened to install fuel tube No. 6. After all tubes are installed, torque the bracket (No. 5) to 32 **ft-lb**.

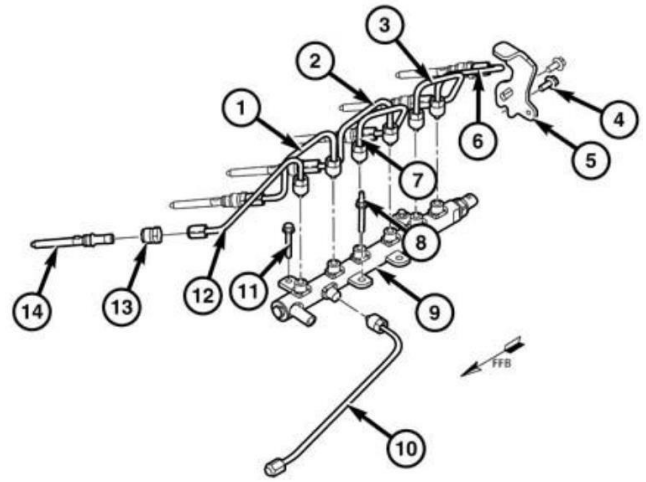

4. Connect the fuel injector solenoid wires and nuts to the top of the injectors. Tighten the connector nuts to 13 **in-lb**.

Note: Be very careful not to overtighten these nuts as damage to fuel injector will occur

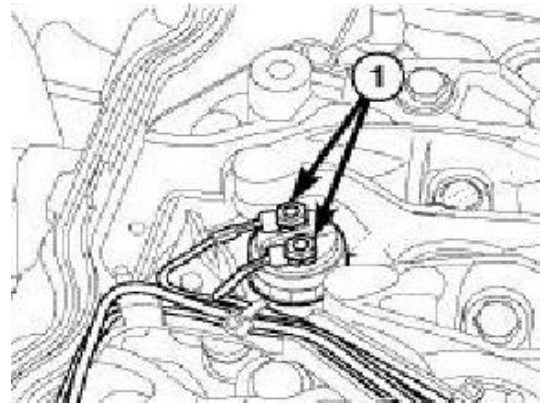

Only 2013-2018 models

5. Reconnect both fuel injector harness connectors.

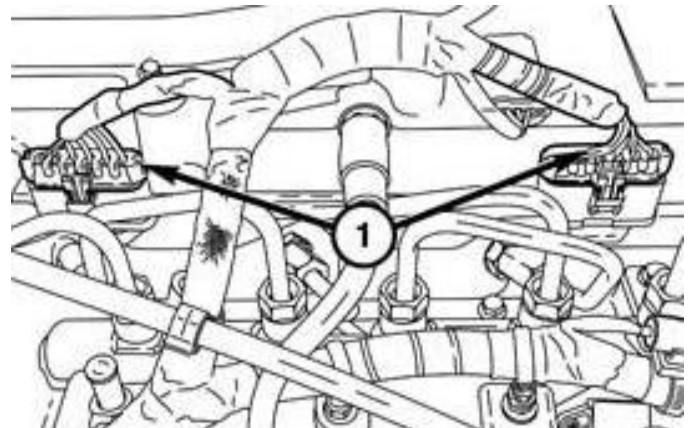

6. Install the intake and exhaust rocker arm assemblies.

Torque bolts to 27 **ft-lb**.

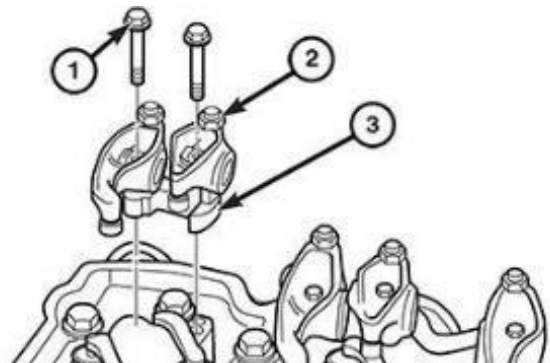

7. Ensure valve lash is within OEM specifications.

	Intake	Exhaust
MIN	.006"	.021"
PREF	.010"	.026"
MAX	.015"	.034"

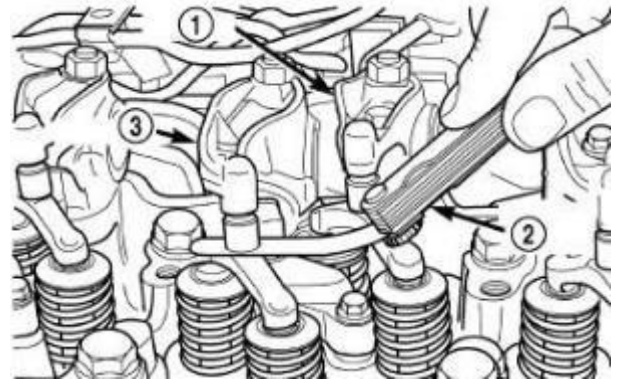

8. Reinstall rocker housing and cylinder head cover.

Connect both negative battery cables.