

(I-00300)

BD Engine Brake LIMITED WARRANTY STATEMENT

BD Engine Brake (the "Seller") warrants the following product(s):

All products manufactured or rebuilt by the Seller are to be free from defects in material or workmanship, which includes but is not limited to Turbochargers, Exhaust and Intake manifolds, Exhaust brakes, Intercoolers, Flex Plates, Transmissions, Torque Converters, Oil pans, Fuel pumps and systems, Electronic monitors and control systems. The Seller warrants to the original buyer of the product (the "Buyer") that it will repair or replace, free of charge, any product which has a defect in material or workmanship within the warranty period described below. Copy of original invoice is required to qualify for warranty.

A defect is defined as a condition within the product that would render the product inoperable under normal conditions of use and service. The Seller's responsibility under this Warranty is limited to the repair or replacement, at the Seller's option, of any warrantable product returned prepaid with complete service history and proof of purchase. A valid proof of purchase is a dated bill of sale or receipt.

A Return Material Authorization (RMA) number, obtained in advance from a customer service representative of the Seller and the dated bill of sale or receipt, must accompany any product returned by the Buyer for warranty determination. The Seller will be the final authority on the approval of all warranty claims hereunder. The issuance of a RMA number does not represent an approval of a warranty claim. BD reserves the right to return or replace Warranty Approved items freight Prepaid. While warranty denied or rejected, claims will be returned freight collect. Accepted warranty products, which have been replaced, will become the sole property of BD.

Until the Seller has approved a warranty claim, the Buyer will be responsible for all costs. Replacement parts and the labor costs incurred by the removal and replacement of the product while performing warranty work will be the responsibility of the Buyer. In no case does the obligation of the Seller exceed the original purchase price of the product as indicated on the original bill of sale or receipt. Under no circumstances will the Seller be liable for any travel time incurred in diagnosis for defects, or any other contingent expenses.

Only once the claim is approved, and depending on if the warrantable product is eligible, labor costs will be considered for the removal and replacement if an eligible part at an hourly rate of \$100.00 per hour. The end user may be responsible for the difference between the BD warranty labor rate and the authorized service dealer's labor rate. BD recommends the end user negotiate these conditions before the service is performed. As well the end user may be responsible for additional freight charges from FOB Abbotsford, BC / Washington.

To the extent permitted by law, the Buyer hereby waives all rights other than those expressly set out herein and acknowledges that this warranty sets out the Buyer's exclusive remedies with respect to products covered by it. This warranty shall not be extended, amended or varied except by written instrument signed by the Seller and the Buyer. If the buyer replaces the product from the Seller with another from another manufacturer, the Buyer-Seller warranty contract is void and the RMA Claim will be terminated. Any claim for remuneration will be rejected.

The Seller will administer warranty requests on products sold by the Seller and not manufactured by the Seller by forwarding claims made by a Buyer under the manufacturer's warranty to the manufacturer. The final disposition of such claims will be made by the manufacturer and ruled by the laws of British Columbia, Canada.

Customer assumes risk in purchasing product with in 30 days may return the product for exchange of other BD products or services only. No cash refunds are available.

The installation of BD aftermarket parts may void the OE warranty. BD is not responsible for OE warranties or how they are administered. Residents of the U.S.A. can reference the Magnuson-Moss warranty act that protects the consumer on the installation of aftermarket parts, please research this act to base your decisions accordingly.

In the case the warranty is denied, BD at its discretion, may offer to refurbish (where applicable) the product at discounted rate for the end user.

Please refer to Warranty time limitation per product.

NOT COVERED UNDER THIS WARRANTY

This warranty is limited to the original purchaser of the product and is not transferable to subsequent owners. Specifically excluded from this warranty are failures of products caused by misuse, misapplication, negligence of the Buyer, accidents, modification, abuse, improper storage, installation, repair or operation, use of unauthorized parts or other mistreatment of the Buyer or his agent. Any competitive use, sled pulling, drag racing will void warranty on product. A sheared or twisted shaft, broken planetary gear sets, burned clutches, broken drive hubs, sun gear damage, cracked housings are not covered. Damage caused from debris in oil contaminated coolers, improper fluids and filters or damage caused from fuel or air contamination, Biodiesel, low fluid levels are also not covered. This warranty does not cover deterioration of plating, paint or any other coating, linings or parts that are subject to normal wear and tear, such as light bulbs, fuses, bearing wear, seal wear, etc.

In the case of BD transmissions, a BD torque convertor must be installed at the time of installation of the transmission. Use of a 3rd party or OE convertor may invalidate the transmission warranty.

If product is not installed by a trained and authorized BD dealer, installation facility must prove it is properly tooled and has certified training to have installed or to carry out repair of product.

The Seller also disclaims any liability for incidental or consequential damages including but not limited to, repair labor, rental vehicles, hotel cost or any other inconvenience cost. To the extent permitted by law, this warranty is in lieu of all other warranties or guarantees, either expressed or implied, included the implied warranties of merchantability and fitness for a particular purpose and shall not extend to any Buyer or to any person other than the original purchaser residing within the boundaries of the continental U.S. or Canada. As well the seller is not responsible or obligated to update previously manufactured parts that are currently under the above warranty.

NOTE THAT THIS GUARANTEE WILL BE VOID IF THE USER BREACHES THE CONDITIONS IN THE SECTION LABELED "NOT COVERED UNDER THIS WARRANTY" AND IS ONLY APPLICABLE ON THE PRODUCTS THE SELLER MANUFACTURES.

DISCLAIMER OF LIABILITY

Other than as expressly set forth herein, the Seller, together with its distributors, jobbers and dealers shall in no way be responsible for the product's proper use and service. In no event shall the Seller be liable for any special, incidental, indirect or consequential damages of any kind or nature, whether or not the Buyer was advised of the possibility of damage, arising or resulting from the use or performance of the product, and the Buyer hereby waives any and all such claims.

The Buyer acknowledges that he/she/it is not relying on the Seller's skill or judgment to select or furnish goods suitable for any particular purpose and that the Seller has no liability that will extend beyond the scope of the limited warranty contained herein, and the Buyer hereby waives all remedies or liabilities, expressed or implied, arising by operation of law or otherwise, (including, without limitation, any obligations of the Seller with respect to fitness for any particular purpose; merchantability; and special, incidental, indirect or consequential damages) or whether or not occasioned by the Seller's negligence.

The Seller disclaims any warranty and expressly disclaims any liability for personal injury or damages related to the Buyer's use of the product. The Buyer acknowledges and agrees that the disclaimer of any liability for personal injury is a material term for this Agreement and the Buyer agrees to indemnify the Seller and hold the Seller harmless from any claim related to the product and its use or performance. Under no circumstances will the Seller be liable for any damages, liabilities, costs or expenses incurred as a result of by reason of the use, performance or sale of the product, including without limitation, any damages, liabilities, costs or expenses incurred by reason of the Buyer's negligence related to those uses of the product as a result of the removal of the speed limiter.

The Seller assumes no liability regarding the improper installation or misapplication of the product. It is the installer's responsibility to check for proper installation, and, if in doubt, contact the manufacturer.

Limited Warranty Details			
Product Name	Parts (Months/Miles) ¹	Labor (Months/Miles) ^{1,2}	Notes
Torque Converters	36/ 150,000	12/12,000	No Race abuse covered
Transmissions (TowMaster & TorqueMaster)	36/ 150,000	12/ 24,000	No Race abuse or broken shafts covered. Remote filter required for inspection with a cooler flow rate in GPM at Oil/Air transmission cooler outlet. Freight provision allowed.
Transmissions (RoadMaster)	24/ 100,000	12/ 24,000	
Rebuild/Repair Transmission	12/ 24,000	12/ 24,000	Defined as "Cost of Repair" or repaired units that fall outside of the retail warranty period.
Race Transmissions	12/ 24,000	Not Eligible	
Valve / Accumulators Bodies	12/ 24,000	12/ 24,000	
Transmission Pans	36/ 150,000	Not Eligible	
Flex Plates	36/ 150,000	Not Eligible	
Injectors (Mechanical) & Injection Pumps	12/ 24,000	12/ 24,000	VP44/P7100 Race Pumps 90 days parts/No labor coverage
Performance Injector Nozzles (Common Rail)	Not Eligible	Not Eligible	
Common Rail Injectors	24 Months	Not Eligible	Manufacturing and material defects are only covered. Cracks caused by high fuel pressure are not covered. High Return flow not covered after 12 months on Performance Injectors. For No Hassle Eligibility, see https://us.bddiesel.com/pages/extended-warranty
	24 Months + No Hassle	Not Eligible	
Performance Tuners and Chips	Manufacturer ³	Not Eligible	
BD Electronic Modules (TSB, VVB, etc)	24/ 48,000	Not Eligible	
Intake / Exhaust Manifolds	36/ 75,000	Not Eligible	
Exhaust Up pipes	12/24,000	Not Eligible	Surface rust not eligible.
Exhaust Kits	Manufacturer ³	Manufacturer ³	
Hoses / Clamps	12/ 24,000	Not Eligible	
BD Xtruded Transmission Cooler	12/ 24,000	Not Eligible	
Manual Transmission Clutches	Manufacturer ³	Manufacturer ³	
Short Shifters	12/ 24,000	Not Eligible	
Engine / Head Stud kits	Manufacturer ³	Manufacturer ³	
Positive Air Shutoff / Electronic Positive Air Shutoff	24/ 24,000	Not Eligible	
Exhaust Brakes	24/ 24,000	12/ 24,000	
Gauges and Mounts	Manufacturer ³	Manufacturer ³	
Screamer Turbos	24 Months	Not Eligible	24 Month warranty effective for sales after 11/01/2024
Performance/OEM Turbos	12 Months	Not Eligible	
Remanufactured ISX Turbos	90 Days	Not Eligible	See I-00437 for more details. For 1045880, see OEM Turbos.
Auxiliary Fuel Pumps	12/ 12,000	Not Eligible	
BD FICM	12 Months	Not Eligible	
Fuel Control Plate/Pin (VE & P7100)	24 Months	Not Eligible	
Distributed Product (Not Manufactured by BD)	Manufacturer ³	Manufacturer ³	
Replacement Components	12 Months	Not Eligible	
Transmission Rebuild/Build It Kits	12 Months	Not Eligible	Material Defects Only
Steering & Suspension Parts (Track Bar, Caster kit, Steering Stabilizer, Bars and links)	Limited Lifetime (12 months if not registered)	Not Eligible	Must register online within 30 days of purchase to be eligible. See website https://warranty.bddiesel.com/limited-lifetime/ for details. Excludes normal wear & tear (boots, bushings, joints, bearings) and improper use.
Venom/FlowMAX Fuel Lift Pump Kit	Limited Lifetime (12 months if not registered)	Not Eligible	Must register online within 30 days of purchase to be eligible. See website https://warranty.bddiesel.com/limited-lifetime/ for details. Excludes normal wear/service items (hose, filters) and improper use.

A Return Material Authorization (RMA) number, obtained in advance from a customer service representative of the Seller and the dated bill of sale or receipt, must accompany any product returned by the buyer for warranty determination.

¹ Warranty is based on whichever occurs first (Months or Mileage).

² Prior approvals must be given to qualify for labor reimbursement.

³ As per Manufacturer's warranty

Updated 10/21/2024



**DOWNLOAD THE LATEST INSTALL
MANUALS AT www.bddiesel.com**



BD PERFORMANCE DODGE T4 5.9L

CUMMINS

EXHAUST MANIFOLD

-- Installation Instructions --

Application List		
1045987-T4	2003-2007	Dodge 24V

-- PLEASE READ ALL INSTRUCTIONS BEFORE INSTALLATION --





**** Important notice on page 3 ****



UNLESS AN EO# IS LISTED, THIS PRODUCT IS LEGAL IN CALIFORNIA FOR RACING VEHICLES ONLY, WHICH MAY NEVER BE USED UPON A HIGHWAY.

KIT CONTENTS:

Please check to make sure that you have all the parts listed in this kit **before** you start the disassembly of your truck.

1045987 – Dodge 2-piece Exhaust Manifold (2003-07)			
1405990-T4	1405981	1405982	1200208
			
Front & Back Manifold Assembly	M10x35mm S/S Bolt	10mm S/S Washer	1/8” NPT Plug
Qty: 1	Qty: 1	Qty: 1	Qty: 2

1405998	1100110	1100111	1100112	1100113
				
Coolant Bracket	1/4” Bolt	1/4” Flat Washer	1/4” Lock Washer	1/4” Nut
Qty: 1	Qty: 1	Qty: 1	Qty: 1	Qty: 1

1462430	1462441
	
M10 x 1.5 x 030 Stud	Nut M10 -1.5
Qty: 6	Qty: 6

This manifold will only fit turbochargers with T4 Turbine Housings.

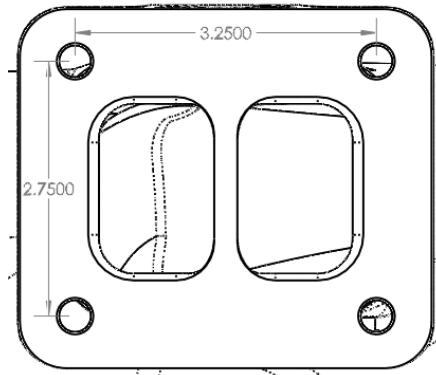

Manifold Joints

BD manifolds use precision, tight tolerance, slip fit expansion joints. These joints reduce stress from thermal expansion and contraction in use. This relieves stress in both the manifold and engine head. Please note this type of joint will slide by hand allowing a simple and easy installation.

How does this joint seal? The internal section is closer to the high temperature exhaust gasses, this heat expands the internal section of the joint more than the larger external section which is cooled by its surroundings. The slip fit then fully seals as soon as EGTs are above 100-200 Deg F.

Options

<u>Description</u>	<u>Part #</u>
24V Exhaust Manifold Gasket Set	1045986

ATTENTION!

THE HIGH TEMP PAINT WILL NEED AT LEAST ONE HEAT CYCLE TO FULLY CURE. UNTIL THEN, THE PAINT WILL BE SOMEWHAT SOFT.

TO HEAT CYCLE THE MANIFOLD, ALLOW THE VEHICLE TO IDLE FOR ABOUT 15 MINUTES, AND THEN LET THE MANIFOLD COOL TO AMBIENT TEMPERATURE.

SCRAPE OFF ANY EXCESS PAINT ON THE GASKET MATING SURFACES. A THIN COAT WILL NOT AFFECT THE SEALING PROPERTIES.

Installation

Disconnect both battery ground cables.

Remove the intake air hose from the front of the turbo and set to the side. You can also remove the air box to aid in additional room.

Remove the V-band clamp that connects the turbo elbow casting to the exhaust down pipe.



Disconnect the compressor outlet boot.



Disconnect the turbo oil supply and the turbo oil drain.



Using a cutoff wheel, cut the coolant line support bracket about 1-1.5" from the coolant tube. Leave enough material to re-connect the new supplied bracket to this tab.

This technique should save you approximately 1 hour of installation time and eliminate the need to drain the coolant.

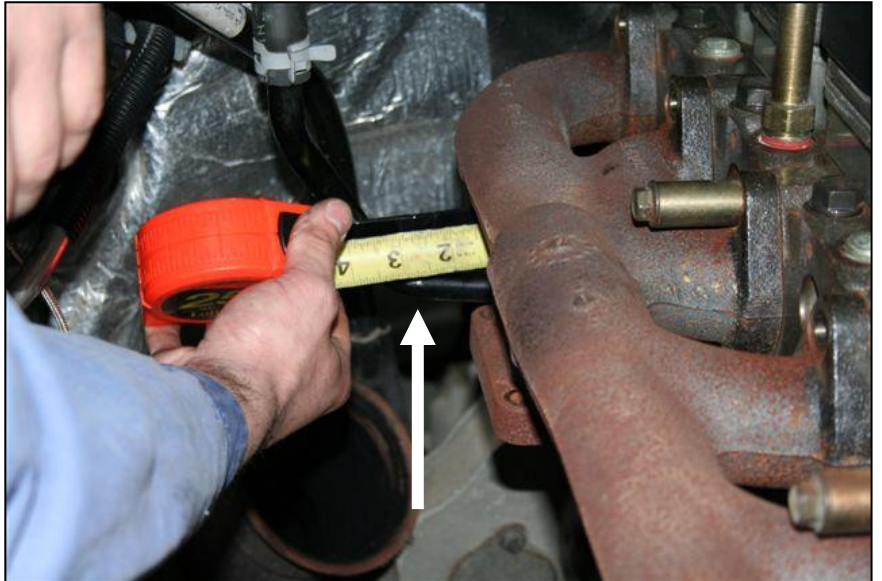

Remove the factory heat shield that covers the front of the manifold.

Remove the factory manifold and turbo assembly. Be sure to save the OE bolts and spacers as you will be reusing them.

Once the factory manifold is removed, clean the head surface of any carbon or soot build up.



Install the 4 supplied studs (#1462430) into the manifold.

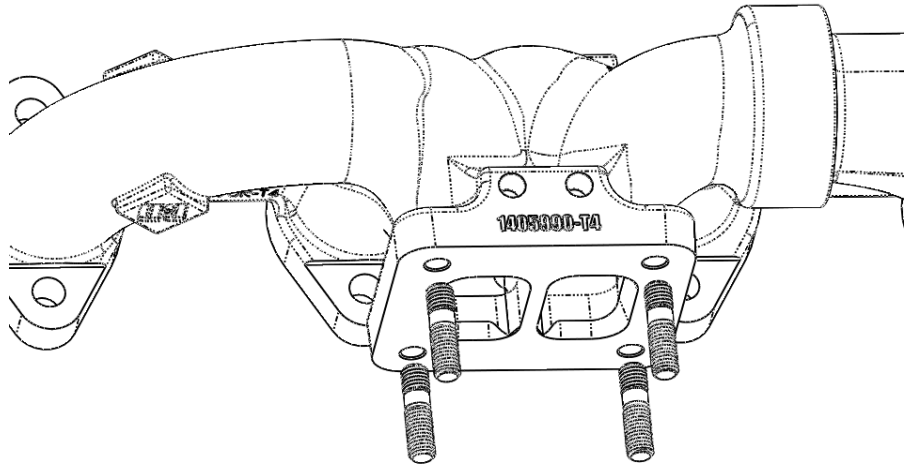

Now install your custom T4 turbo of choice with a new gasket, use the low-profile flange nuts to secure your installation (#1462441).

Torque turbo flange to **32 ft-lbs**

Important! Improper turbo flange torque can lead to gasket failure, and flange damage!

With the whole assembly tight, re-install it to the engine.

Be sure to install a new gasket for each cylinder. It does not matter which way the ridge on the gasket faces.

Torque the bolts to **35 lbs-ft.**

Note that you may need to align the front or rear manifold to match the threaded holes on the cylinder head. You can use a rubber mallet to do this.

When installing the lower bolt to cylinder #5, discard the factory bolt and spacer. Place the coolant pipe bracket against the manifold and install the **M10 SS socket head bolt (1405981)** and the **M10 Washer (1405982)** to secure the bracket and the manifold to the head.

Before tightening the bolt, line up the bracket to the OEM coolant pipe tab that you cut earlier.

Torque the bolt to **35 lbs-ft.**

Note: On 2006 model year vehicles, you will need to secure the bracket to cylinder # 6.

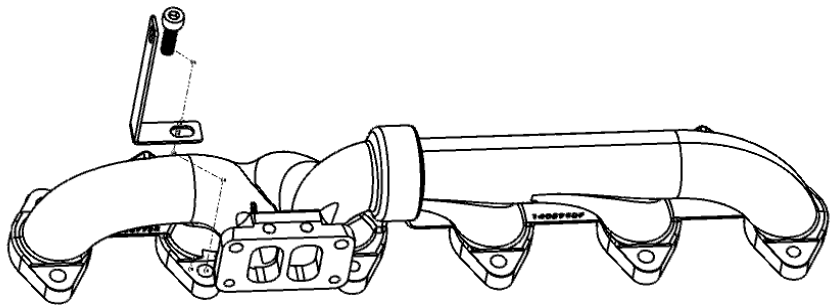

Given this manifold supports custom sized turbochargers utilizing the T4 exhaust housing foot print the next instruction step maybe incorrect for your custom application.

You now have the option to drill a hole through the OEM coolant pipe tab and secure the brackets together using the $\frac{1}{4}$ bolt (1100110), $\frac{1}{4}$ " flat washer (1100111), $\frac{1}{4}$ " lock washer (1100112), and the $\frac{1}{4}$ " nut (1100113) supplied. Use a $\frac{5}{16}$ " drill bit to accomplish this.

Or, you can spot weld the bracket and the OEM coolant pipe tab together.

If you choose to weld, be sure to paint the weld after.

Once that is secure, connect the downpipe to the turbocharger.

Reconnect the turbo oil drain and oil supply.

Reconnect the air inlet pipe to the front of the turbo and re-install the air box if you had removed it.

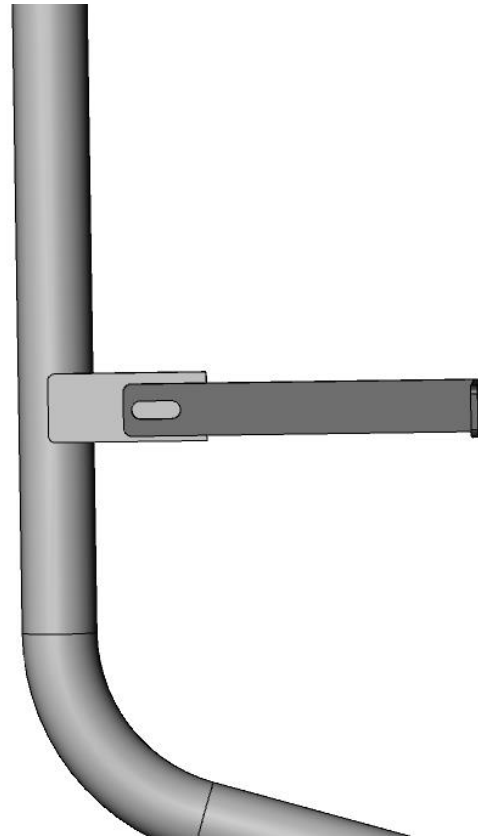

RE-TORQUE ALL BOLTS AFTER AT LEAST ONE HEAT CYCLE

CHECKLIST FOR INSTALLING TURBOCHARGERS

1. Inspect the intake and exhaust systems leading to and from the turbocharger to ensure absence of foreign material, including burrs and loose lining fragments.
 - a. Be thorough – even small particles can cause severe rotor damage if inducted during high speed operation.
2. Use new and approved gaskets at the various air, oil and exhaust connections to the turbocharger
 - a. Avoid the use of sealing or jointing compounds at all flanged connections.
3. Use a high temperature anti-seize compound (such as Fel-Pro C5A) on all threaded fasteners connected to the turbocharger.
4. Limit the drain port tilt to 20° from bottom center in either direction.
 - a. Tilting in excess of this amount can create a low-idle leakage tendency at both the turbine and compressor seals.
5. Fill the oil inlet port to overflowing with clean engine oil before connecting the oil feed hose to the turbocharger.
6. If the clamp tabs or V-band are loosened for angular orientation of the compressor cover or turbine housing, be certain that the mating flanges are tightly resealed, and that the fasteners are retightened to the torque levels specified in the appropriate manual.
 - a. Complete the orientation of the cover and housing before making any rigid connections to the compressor inlet and outlet, or to the turbine outlet; this will make certain that all ducting aligns closely with the turbocharger; this will minimize the external stresses acting on the unit.
7. Before connecting the oil drain hose, crank the engine without firing until a steady stream of oil flows from the drain port.
8. Operate the engine at low idle for at least three minutes after completing the installation of any turbocharger. This will prevent oil starvation damage to the bearing system, and will tend to purge any residual contaminants from the bearing housing prior to the unit acceleration.
9. Always change the engine oil and filter when replacing a turbocharger.
10. Replace or clean the air filter.
11. In case of previous failure, inspect CAC for debris. Clean if necessary.

NOTE: Warranty will be denied if the turbocharger is installed on any application not previously approved by BD Diesel Performance.

General Factors Affecting Turbocharger Service Life

An analysis of turbochargers removed from service indicates that approximately 40% of the troubles are due to foreign material going through either the turbine or the compressor. An additional 40% are due to lubrication failures. The remaining 20% are of a miscellaneous nature.

Some of the foreign material damage is the result of pieces of burned or broken valves and combustion cups going through the exhaust system into the turbine. Other turbine damage is due to casting fins that may break out of the manifolds and ports. Occasionally improperly installed gaskets will permit pieces of gasket to overhang a port and break off into the exhaust system. Damage due to the nuts and washers that are dropped into the exhaust system is also altogether too frequent. Occasionally engine suffer from scuffed and broken pistons. Pieces of these pistons will damage turbine wheels.

Compressor wheel breakage also occurs due to foreign material although not as frequently as turbine wheel damage. Sometimes pieces of the air cleaner will break loose and go through the compressor. There have also been instances where hose connections fail and pieces of rubber or wire reinforcing from the hose gets into the compressor wheel.

Again, carelessness in allowing nuts, bolts and washers to get into the intake system sometimes causes compressor wheel failures.

Lubrication failure may be any one of a number of types. Undersized or plugged oil lines are quite common. It is essential to have an adequate supply of oil at full engine oil pressure for turbocharger bearings. The turbocharger runs at very high speeds and will very quickly overheat with even a momentary failure of oil supply.

The oil supplied to the turbocharger should first pass through a good filter of adequate size so that there is always full oil pressure at the turbocharger bearing. With an adequate supply of clean oil, turbocharger bearing will run for thousands of hours with no measurable wear.

Failure may occur due to extreme exhaust temperatures encountered in excessive altitude operation. Any engine that is operating close to its limits on exhaust temperatures at sea level will have excessive exhaust temperatures when operated at altitudes above 5000 feet.

Altitude operation will cause the turbocharger speed to increase and may cause failures due to over speeding as well as high temperatures unless the engine's fuel system is derated according to the manufacturer's recommendations.

Inlet restrictions due to plugged air cleaners, collapsing hose connections, or undersized air pipes have the effect of reducing the air supply to the engine and result in excessive exhaust temperatures. Both inlet restriction and the excessive altitude operation can cause turbine wheel failures due to excess temperatures.

With any turbocharger, it is possible to accumulate enough dirt in compressor housing and diffuser to reduce the airflow capacity and the efficiency of the compressor if air cleaning system is not maintained. Reduced air flow will cause the engine to run hotter and may result in burned valves and pistons which in turn will cause turbocharger failure.

Leaking gaskets or connections on either the intake or exhaust system of the engine will cause a reduction in the air supply to the engine and will result in high exhaust temperatures.

Sometimes air connections and exhaust connections are made in such a manner that thermal expansion of the exhaust manifold and other parts connected to the turbocharger will produce very high loads on the turbocharger. These high loads result in housing distortions that cause the compressor and turbine wheels to rub.

Excessively heavy piping that is supported only by the turbocharger may also cause distortion.

Turbocharger mounting that are not sufficiently rigid to prevent excessive vibrations in the turbocharger can also cause distortions and failures.

In conclusion it can be stated that every few turbocharger failures would occur if no foreign material were permitted to enter either the turbine or the compressor; if precautions were taken to prevent excessive exhaust temperatures, and if the turbocharger were always supplied with an adequate amount of clean oil.

IMPORTANT SAFEGUARDS

WARNING:

Misuse or modification of the turbocharger can result in serious injury and property damage. Basic safety precautions including the following should always be followed.

1. Read and comply with all instructions including “Checklist for Installing Turbochargers” before installing or using turbochargers. Read “General Factor Affecting Turbocharger Service Life”. (Contact BD Diesel Performance for any additional copies).
2. Install turbocharger only on an engine which has been approved for such application (check BD Diesel Performance Catalog). The turbocharger is a precision built product which has been matched and test for the intended application.
3. Do not modify or substitute any parts of turbocharger. Do not remove metal from any part of the turbocharger.
4. Disassembly and reassembly should done only in accordance with the appropriate set of the instructions provided with the turbocharger.
5. Do not modify or substitute any parts of the engine except in accordance with the engine owner’s manual. Do not modify engine fuel control system or restrict exhaust system or inlet excessively.
6. Do not operate at excessive altitudes (consult engine owner’s manual for altitude restrictions).
7. Be sure that oil supply and drain line are adequate (see “Check List for Installing Turbochargers”).
8. Always warm up engine for 2-5 minutes to allow oil to reach the turbocharger before operating under load.
9. Performance all maintenance specified by the engine manufacturer each time or at intervals maintenance is recommended by the engine manufacturer. Concurrently inspect turbocharger for any deficiencies described in the “General Factors Affecting Turbocharger Service Life”, and correct all observed or suspected deficiencies before operating the engine and/or turbocharger.
10. SAVE THIS LIST OF IMPORANT SAFEGUARDS, THE ENGINE OWNER’S MANUAL, “CHECKLIST FOR INSTALLING TURBOCHARGER”, AND “GENERAL FACTORS AFFECTING TURBOCHARGER SERVICE LIFE”.



**DOWNLOAD THE LATEST
INSTALL MANUALS AT
www.bddiesel.com**



BD Iron Horn Series

Dodge 5.9L T4 Turbo Kit

1045169 - 1045179

Dodge 2003-2007

PLEASE READ ALL INSTRUCTIONS BEFORE INSTALLATION

2003-2004 Model year trucks:

A 2004.5-2007 downpipe is required, such as FLOPRO Part # 20811 and OEM V-band Part # 52121285AA

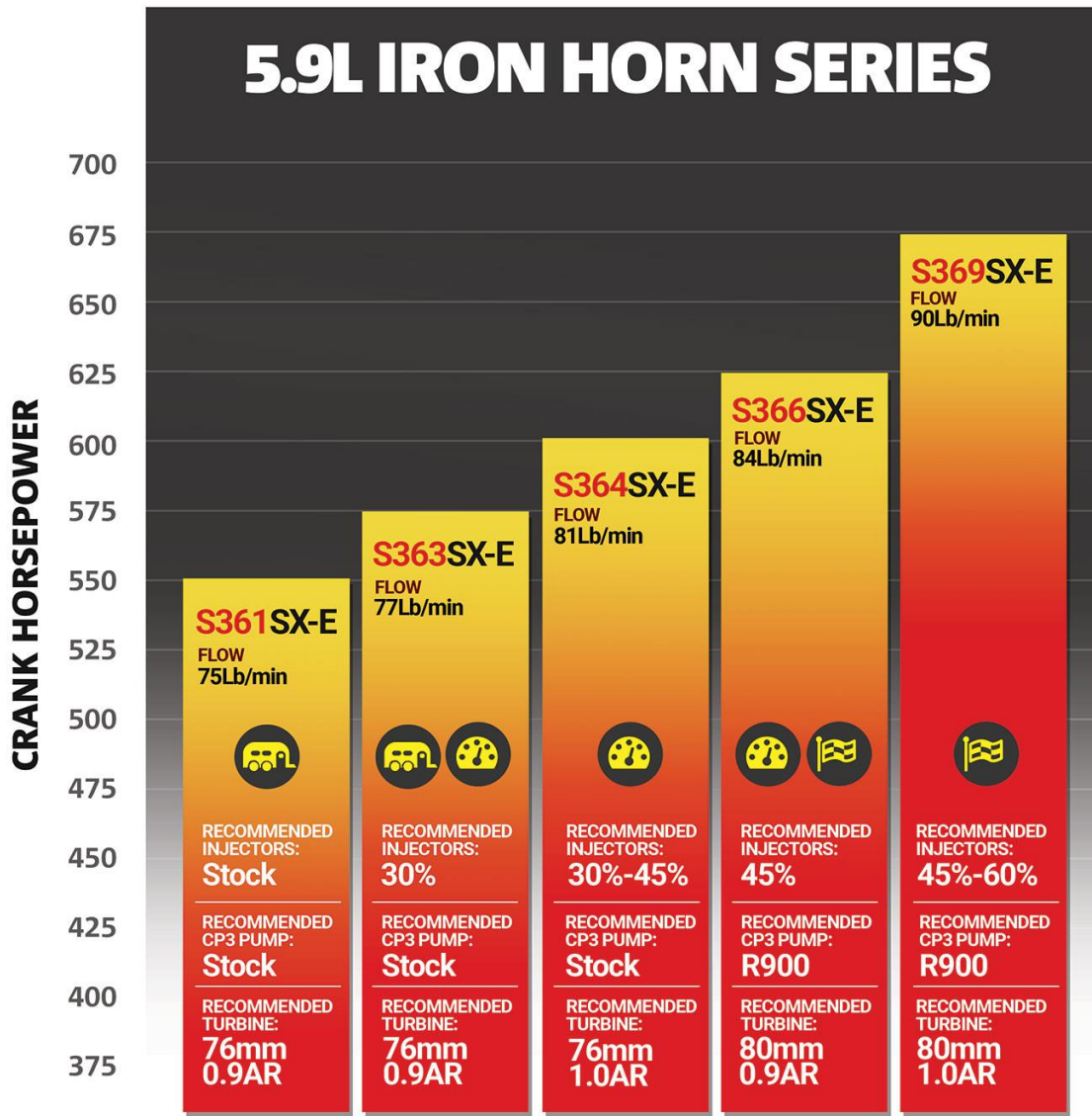

BD Part Number	Compressor Wheel Inducer Size	Turbine Wheel/ Housing AR Ratio
1045169*	64.5mm	76mm - 1.0AR
1045170*	61mm	76mm - .91AR
1045171	64.5mm	76mm - .91AR
1045172*	63mm	76mm - .91AR
1045173	63mm	80mm - .91AR
1045174	64.5mm	80mm - .91AR
1045175	64.5mm	80mm - 1.0AR
1045176*	66mm	80mm - .91AR
1045177	66mm	80mm - 1.0AR
1045178	69mm	80mm - .91AR
1045179*	69mm	80mm - 1.0AR

* BD's recommended turbine sizes

Please be aware that non-wastegated turbochargers are extremely sensitive to overspeed failures. Turbocharger must be sized correctly to match our horsepower and boost goals. Do not exceed the recommended turbo wheel speed. Compressor outlet pressure can be used to estimate turbo wheel speed. A boost leak will cause higher wheel speeds at a given boost pressure. The below table is rated at a maximum rpm of 3000.

Whether you are towing, at high altitude, or at WOT, high Exhaust Gas Temperature (EGT) is a sign you are operating outside the intended purpose of the turbocharger.

Engine: Dodge Cummins 5.9L ISB			
Turbocharger	Max Compressor Outlet Pressure	Max Shaft Speed	Max Crank Horsepower
S361/76	38 psi	133,000 RPM	550
S363/76	40 psi	133,000 RPM	575
S364.5/76	43 psi	133,000 RPM	600
S366/80	45 psi	126,000 RPM	625
S369/80	50 psi	126,000 RPM	675





Overspeed can result in turbine wheel separation, worn/damaged journal bearings, thrust damage, and split compressor wheels. Using a correctly sized turbocharger will reduce the chances of failure.

- Note you can always overspeed a turbocharger. Play it safe, there are no warranties for overspeed.
- Factory intercooler can have a 5psi pressure drop, i.e. 45psi manifold pressure = 50 psi compressor outlet pressure.
- All out testing is done at the standard RPM range of the engine. If you exceed this RPM, your turbo speed will also increase.
- Extended injector duration will contribute to high EGT's and turbo over speed.



Kit Contents:

Please check to make sure that you have all the parts listed in this kit **before** you start the disassembly of your truck.

Turbo Kit				
Turbo	1462431	1453105	1405100	1405101
				
<i>Turbo</i>	<i>Stud; M10x25mm</i>	<i>Drain; Oil</i>	<i>Clamp; Exh Elbow</i>	<i>Exh Elbow</i>
Qty: 1	Qty: 4	Qty: 1	Qty: 1	Qty: 1
148062		1453152	FT-110120342	
				
<i>Gasket; Oil Drain</i>		<i>Fitting; 1/4MNPTxORFS (-6)</i>	<i>Bolt; Hex 3/8"-16x3/4</i>	
Qty: 1		Qty: 1	Qty: 2	
1453240	1045987-T4		1045986-T4	
				
<i>Wastegate Connector</i>	<i>T4 Manifold Kit</i>		<i>T4 Gasket Kit</i>	
Qty: 1	Qty: 1		Qty: 1	

Introduction

The BD Turbo kit is an economical solution to have a S300 kit on your Cummins. This kit includes a non-wastegated T4 Turbocharger, and a high-performance manifold. The kit retains the stock intake. This is great for those looking to upgrade their stock turbo without breaking the bank.

Pre-Installation Inspection

When replacing a turbocharger BD recommends the following precautions are taken:

- Replace or clean the air filter.
- Change the engine oil and filter.
- Inspect Intake and CAC passages for debris, and clean if necessary.

In the case of a previous failure also include the following steps:

- Inspect CAC for debris and cleanout if necessary.
- Inspect engine oil for debris. Flush system if debris was present.

Ensuring that these steps are followed will prolong the life of your new turbocharger.

Required Tools

- 7mm-22mm Metric Socket and Wrench Set
- 5/16"-9/16" Socket and Wrench Set
- Hose Clamp Plier
- Torque Wrench

Optional Accessories

- | | |
|--------------------------------|-------------------|
| • BD Flow-Max fuel lift pump | 1050305D/1050310D |
| • Throttle Sensitivity Booster | 1057730/31/32 |
| • X-Intake Elbow | 1041555 |

ATTENTION

- 2003-2004 Model year trucks require an aftermarket downpipe such as the **FLOPRO # 20811**
- Please note that speed sensor port on the compressor cover is **NOT** drilled through.

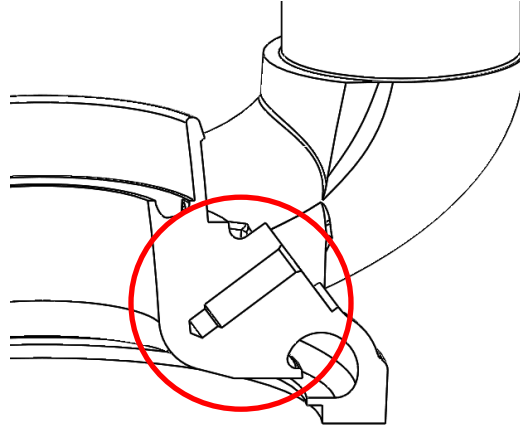
**Removal**

VEHICLE SHOULD BE SAFELY SECURED BEFORE INSTALLATION.

1. Disconnect batteries and raise vehicle.
2. Disconnect the IAT sensor.



3. Remove the intake hose using a 7mm socket.



4. Remove the passenger side inner fender well with a 5/16" socket.



5. Remove the exhaust cast elbow v-band clamp from the back of the turbo with a 7/16" socket.



6. Remove the turbo oil drain line with a 10mm socket. Remove the oil drain out of the engine block.

****Note:** Some models require you to loosen gear clamps to remove the oil drain hose.

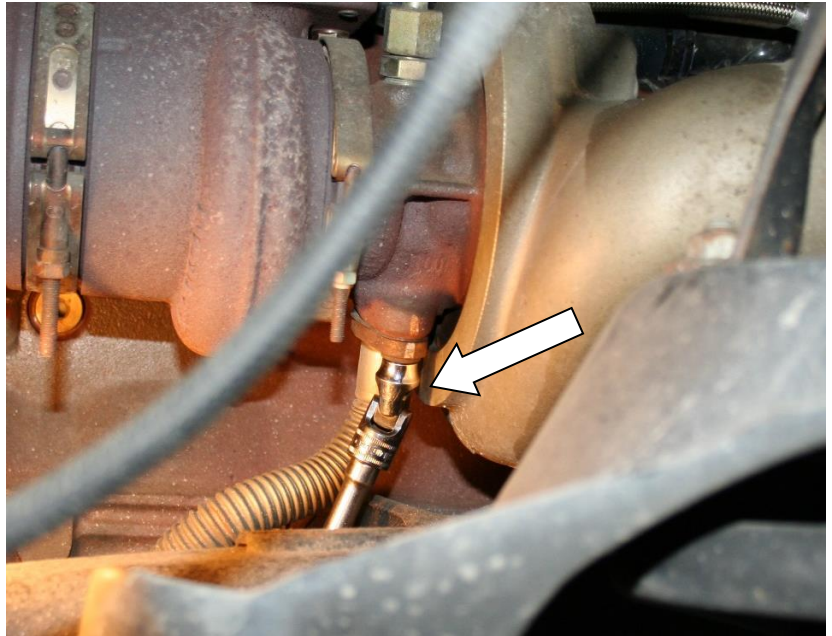

7. Cut the heater pipe bracket to assist in releasing the manifold.



8. Remove turbo oil feed from the turbo.



9. On 05-07 trucks, you will need to disconnect the wastegate solenoid connector.



10. Remove the passenger side intercooler hose band clamp with a 7/16" socket.



11. Pry off the metal lock from rear manifold bolts, remove the heater pipe bracket from the bracket.

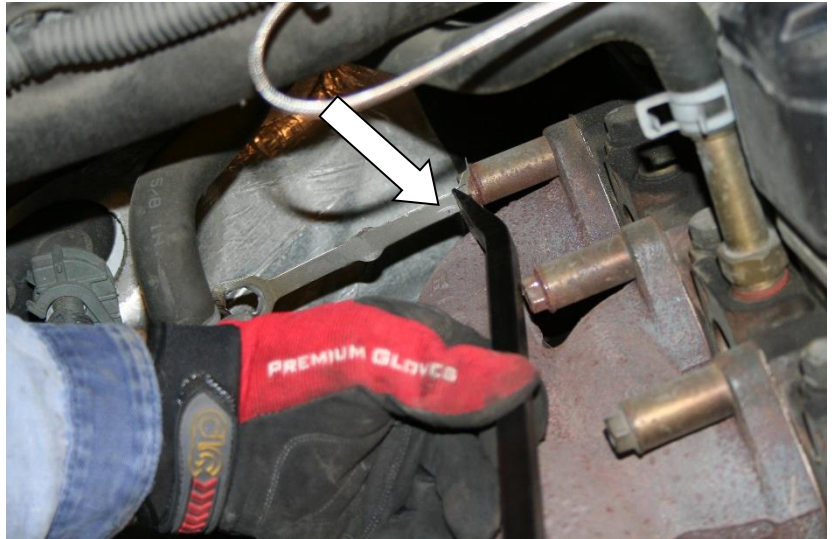

12. Remove the manifold heat shield with a 15mm socket.



13. Remove the remaining manifold bolts using a 13mm socket.



14. Remove the turbo/manifold assembly from the engine compartment.

CAUTION: The turbo/manifold assembly is very heavy. You may require help to lift it out safely.



Installation



VEHICLE SHOULD BE SAFELY SECURED BEFORE INSTALLATION.

1. Install 2 30mm M10 studs supplied with the manifold kit in the top position of cylinder 4 and bottom position of cylinder 5. Make sure the mating surface between the manifold and cylinder heads is clean.

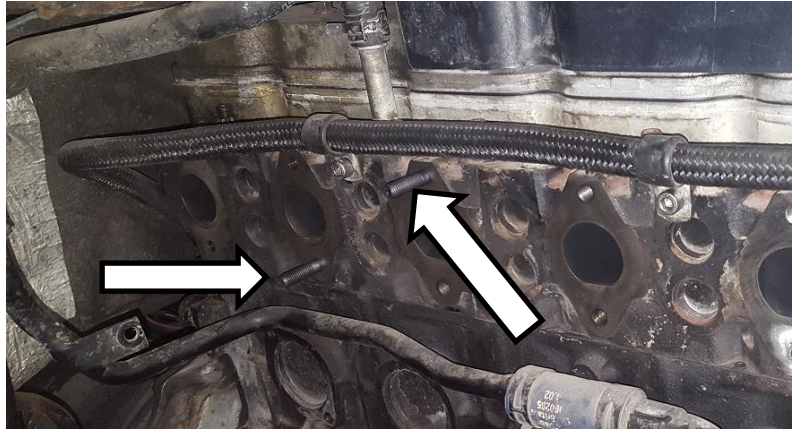

2. Install 4 supplied 25mm M10 studs onto the T4 flange. Use the 1/8NPT plugs to block the port on the manifold if not being used.

****Note:** Discard 4 extra 30mm stud supplied with the manifold kit.



3. Install the BD Manifold using the supplied gaskets.

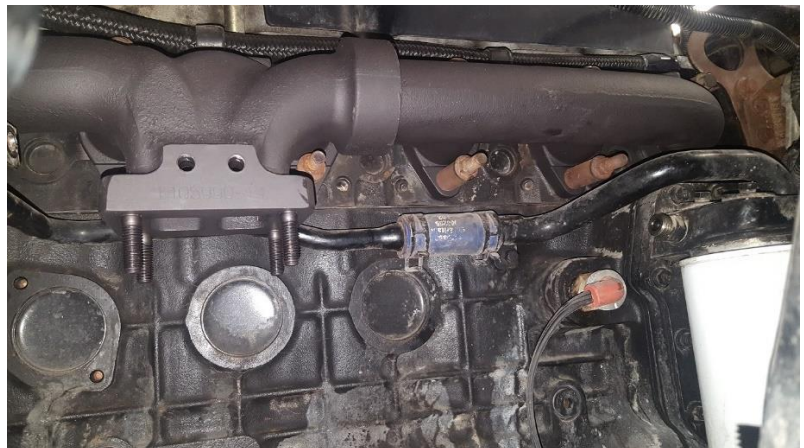

4. Install the coolant line bracket (1405998) as shown.



5. Drill a 5/16" hole on the cut off factory coolant bracket and use the provided hardware to secure the brackets together.
6. Tighten manifold, starting from the center and moving in an outward pattern, tighten the manifold nuts and bolts to **35 ftlbs.**

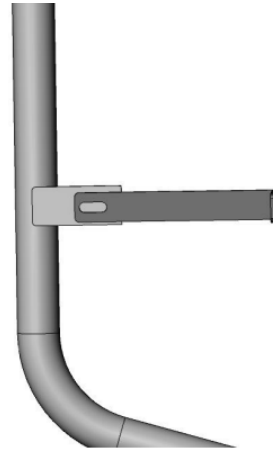

7. Secure the turbo charger to the manifold with the supplied nuts.
8. Torque turbo flange to **32 ftlbs. Important! Improper torque of flange can lead to exhaust leak, gasket failure and flange damage.**
9. Secure the provided exhaust elbow (1405101) to the turbo charger with the supplied clamp (1405100).



10. Check that there is approximately 1/4" clearance between turbo and shock tower. Clock turbo if required, see step 10.



11. To clock turbo loosen all 8 bolts on turbo compressor housing and rotate the housing clockwise till there is approximately 1/4" gap between the housing and the shock tower.

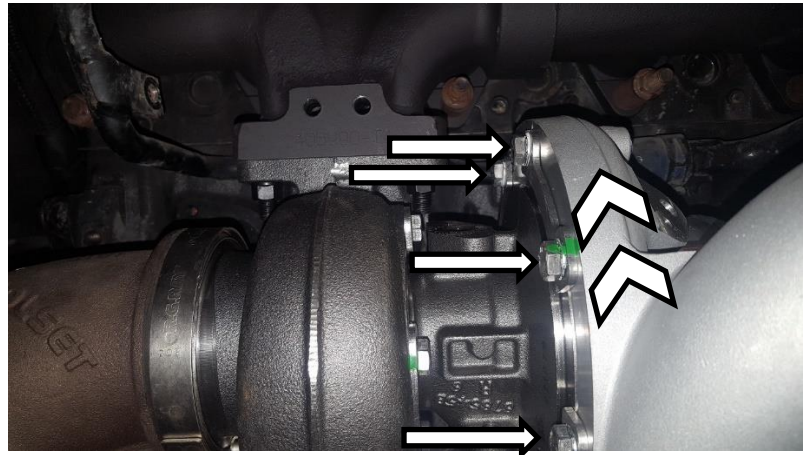

12. Install the supplied (1453152) oil supply fitting onto the turbocharger with a light amount of thread sealant.

****NOTE:** This is a tapered fitting, do not overtighten fitting, it will lead to cracked CHRA.

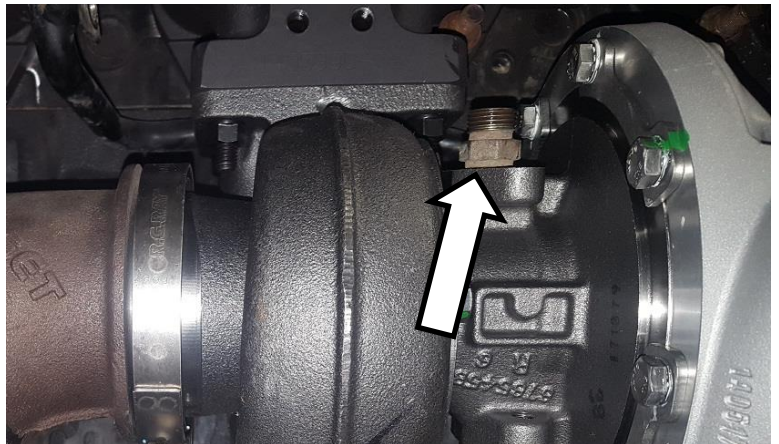

13. Install the supplied corrugated oil drain (Not shown in picture).
Shape to fit. Ensure continuous down flow for the oil

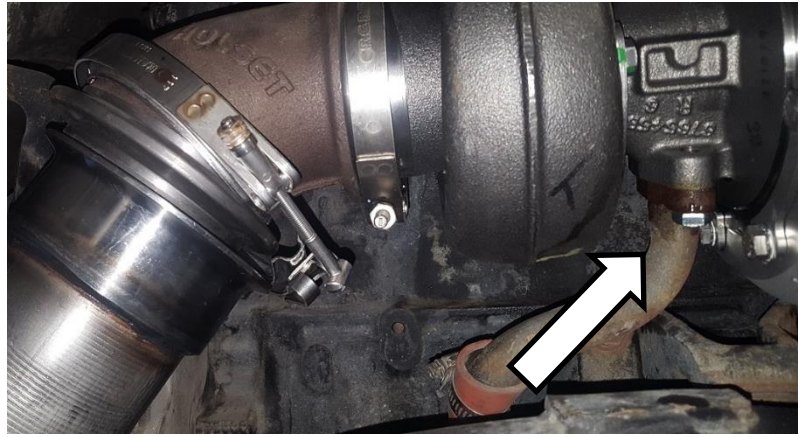

14. Install the oil supply line (reuse OE line).

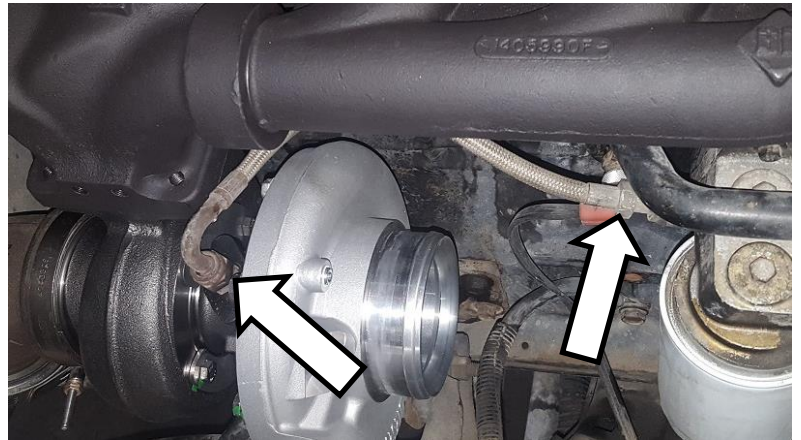

15. Connect the CAC pipe and boot to the turbo charger. Tighten clamps.



16. Connect the exhaust to the downpipe. Tighten clamp.

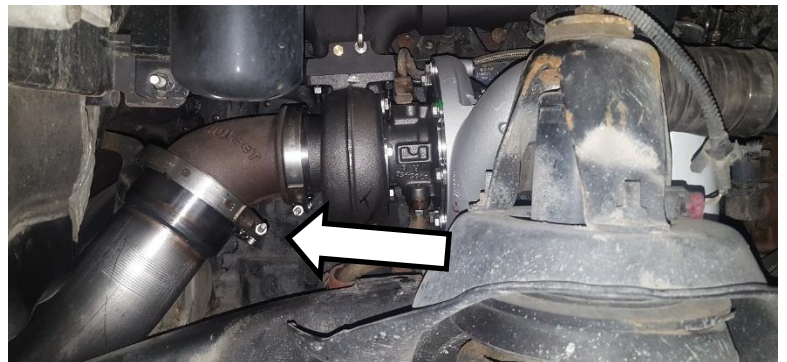

17. Install the intake tube and airbox.
Connect the IAT sensor.
18. Reinstall the inner fender well.
19. Connect batteries.

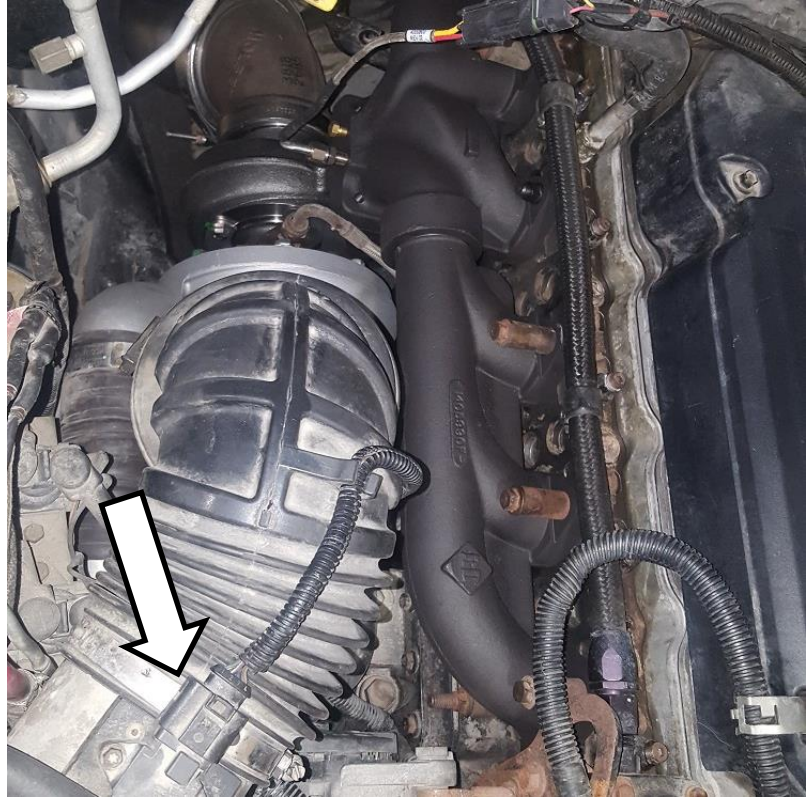

Troubleshooting

Error Code	Solution
P0234	Install a BD boost fooler (1515935, 1515936) or consult with your preferred aftermarket tuning provider
P0236	Clean air filter. If problem persists, consider installing a set of performance fuel injectors or consult with your preferred aftermarket tuning provider.
P0243	Check that wastegate fooler is present, undamaged, and has a good connection.