



***DOWNLOAD COLOUR
INSTALL MANUALS AT
www.bddiesel.com***



68RFE Line Pressure Module

2007-2018 250PSI

1030369

2007-2018 220PSI

1030366



PLEASE READ ALL INSTRUCTIONS BEFORE INSTALLATION



KIT CONTENTS

Please check you have all the parts listed before you begin installation

Kit # **1030369** (2007-2018 6.7L 250psi 68RFE) contains:

Kit # **1030366** (2007-18 6.7L 220psi 68RFE) contains:

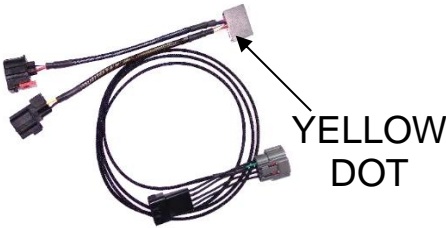
1600368	1300131
	
68RFE 250psi Pressure Module	Tie Wrap (6")
QTY: 1	QTY: 8

1600370	1300131
	
68RFE 220psi Pressure Module	Tie Wrap (6")
QTY: 1	QTY: 8

Line Pressure Module Operation

The BD 68RFE Line Pressure Module increases line pressure above stock levels to aid in holding applied transmission clutches and prevent clutch slipping. Stock line pressure varies between 60-160psi, with the **1600368** module installed the range becomes 60-250psi. With the **1600370** module installed the range becomes 60-220psi. At low load situations the module will not command any additional pressure, but as engine boost rises (and power output increases) the module will increase the line pressure to 250psi/220psi depending on the module.

Line Pressure Module installation

Connect the BD pressure module inline between the Line Pressure Sensor and the OEM harness. Secure the BD module to the OEM harness using the provided tie wraps. Route the MAP sensor wire over the transmission and to the back of the intake horn. Connect it in line with the factory MAP sensor. Secure the wiring harness with supplied tie wraps and keep away from moving parts like the steering shaft or front drive shaft. Ensure connections are fully mated and have clicked together.

Line pressure Sensor Connection

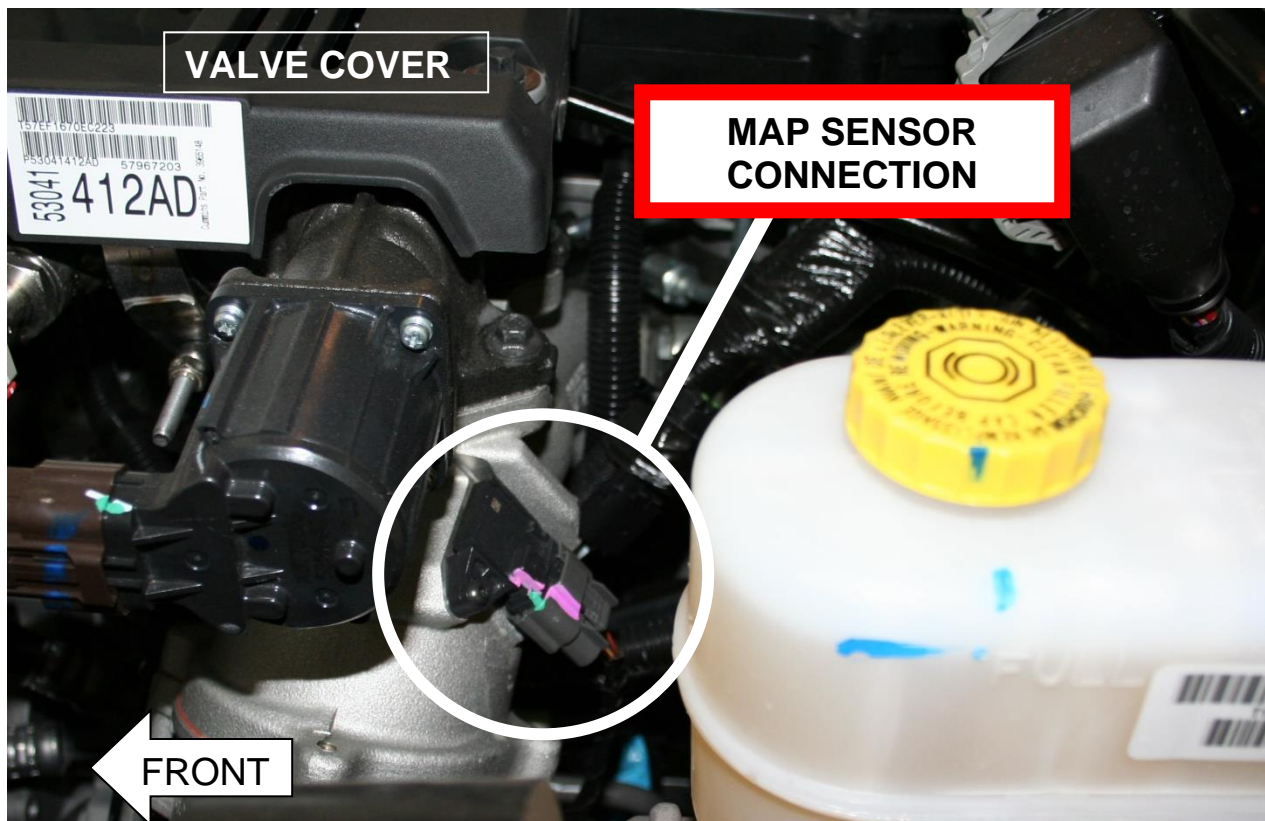
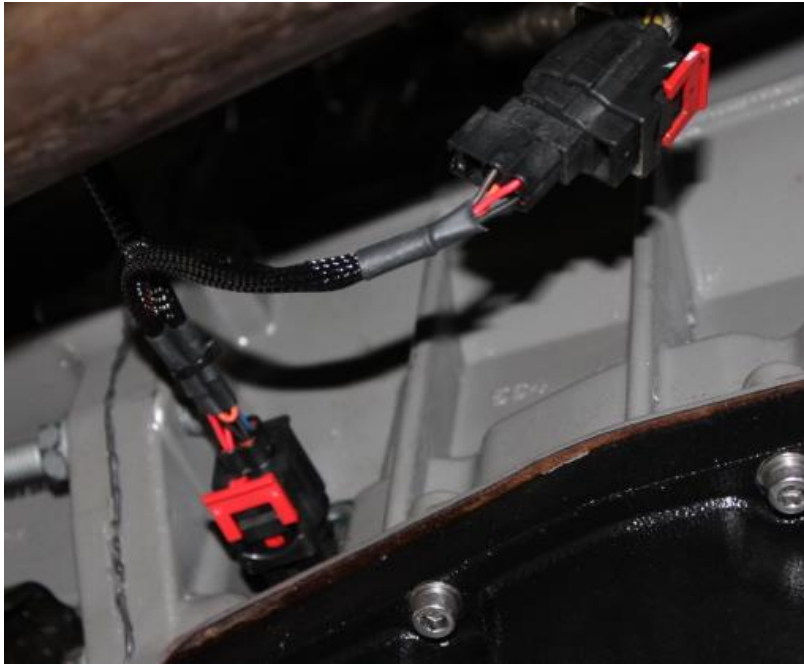

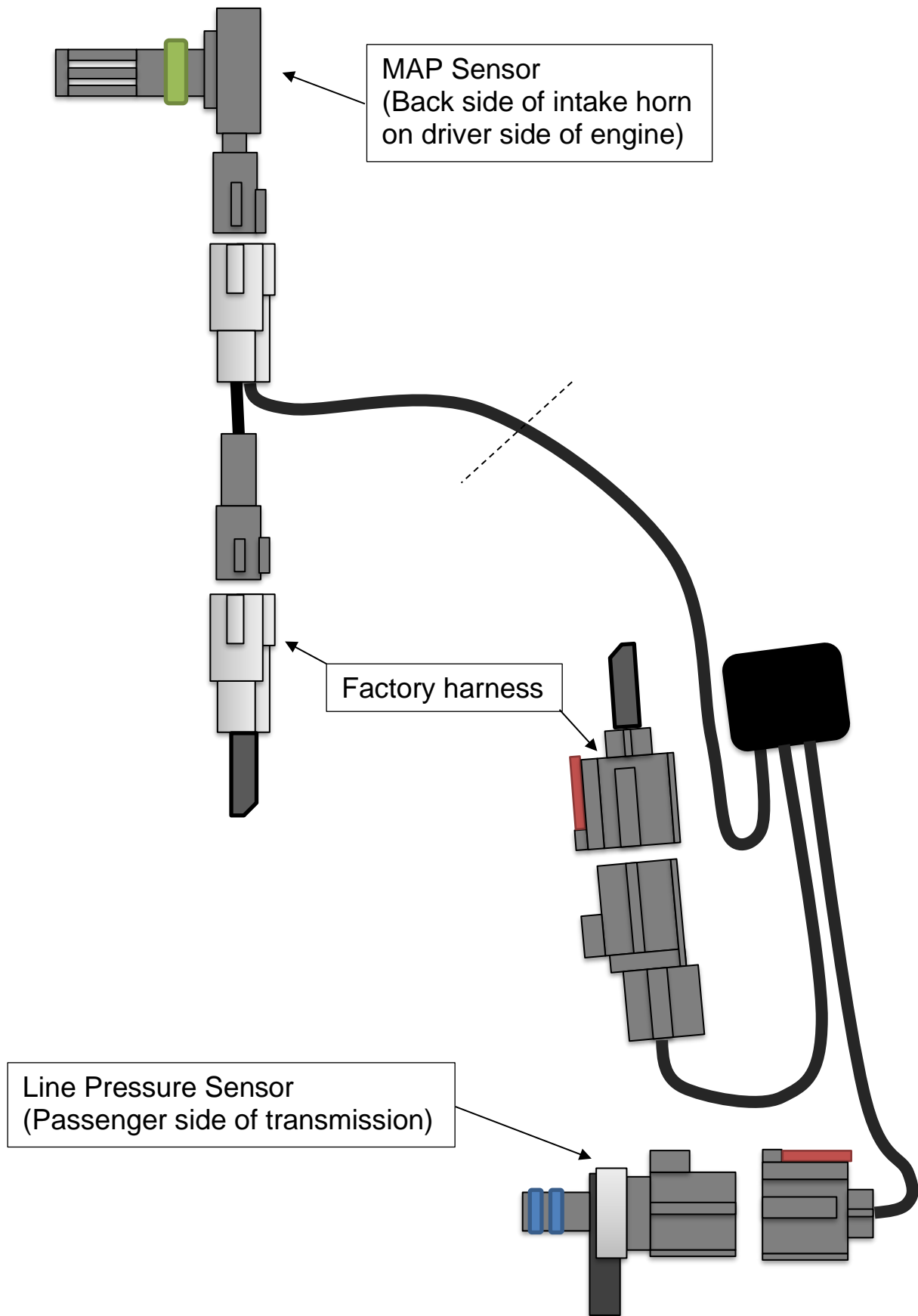



*DOWNLOAD THE
LATEST INSTALL*

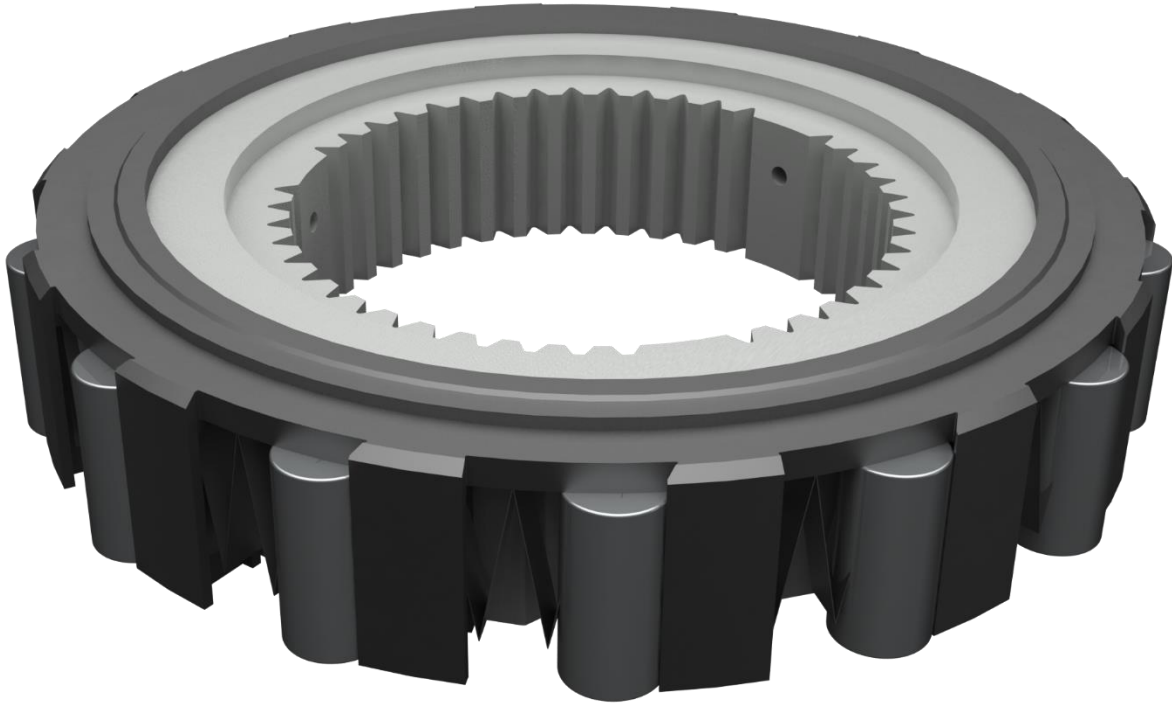

BD 68RFE ONE WAY CLUTCH

**2007-2016 Dodge
Installation Instructions**

1060603

2007-2016 Dodge 68RFE

PLEASE READ ALL INSTRUCTIONS BEFORE INSTALLATION.

Pre-Installation

Remove the previous 68 RFE low rev sprag and discard the internals. Retain the outside sprag gear, retaining plate and the snap ring. They will be used in this build.

REMOVAL

1. Ensure you have your stock 68 RFE Low Rev sprag ready for disassembly. Check to make sure it is not damaged.



2. Remove snap ring and the retaining plate from the sprag and do not discard.

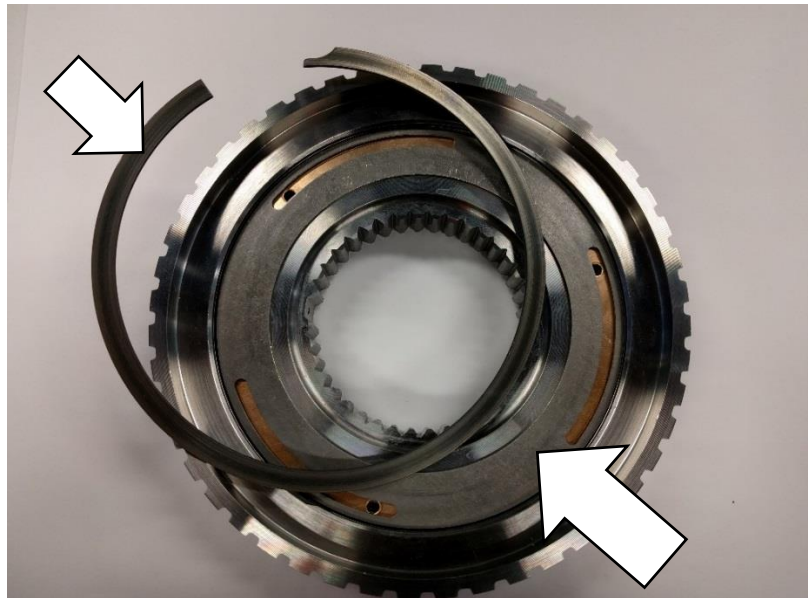

3. Flip the sprag and carefully remove the internal assembly by pushing on the retaining plate.

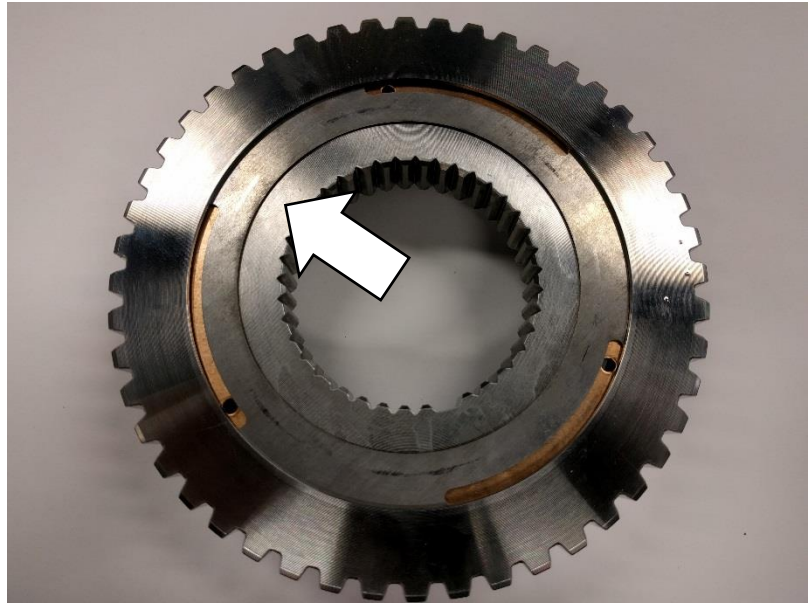

4. Retain the external gear from original sprag.



5. Original snap ring and retaining plate will also be required to complete this build.



6. Remove the part 1060603 from packaging.



7. Ensure the part is in the same orientation as the image.



8. Lift and rotate the internal gear clockwise until the internal gear is sitting proud relative to rollers and cage.

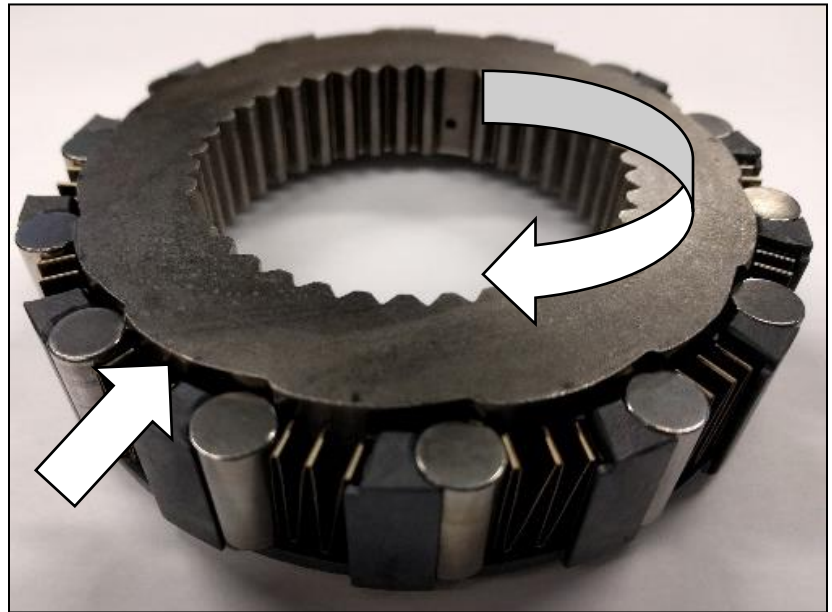

9. Seat the retaining plate within your external part of the 68RFE sprag.



10. Flip 68RFE components upside and drop onto 1060603 while holding the retaining plate in place.



11. Flip the assembly over again and there should be a gap between the top face of internal gear and cage.

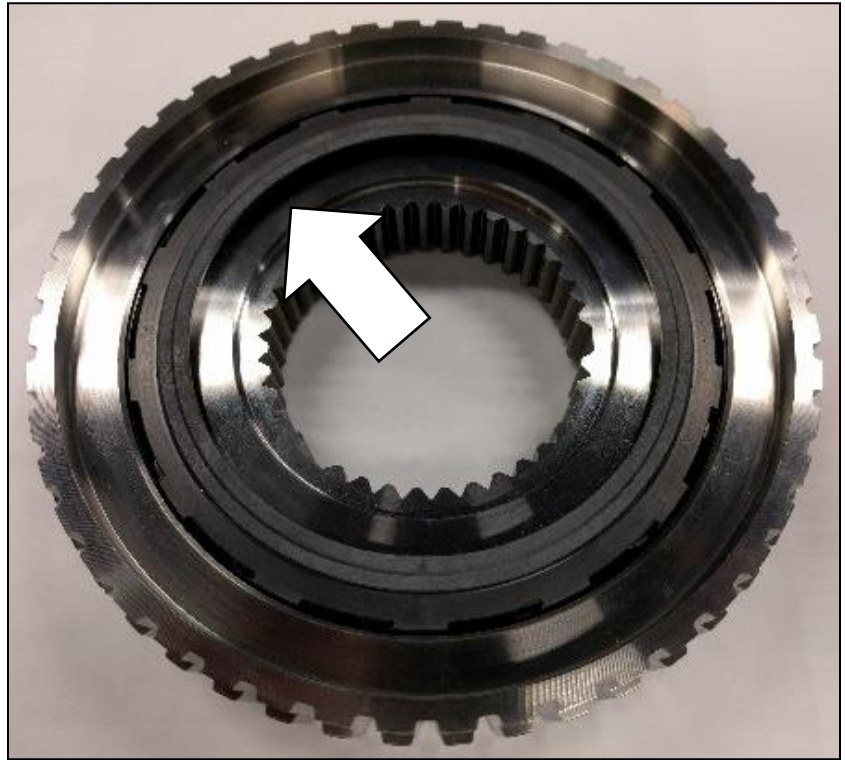

12. Rotate internal gear clockwise until the cage is sitting flush against the top face of internal gear.

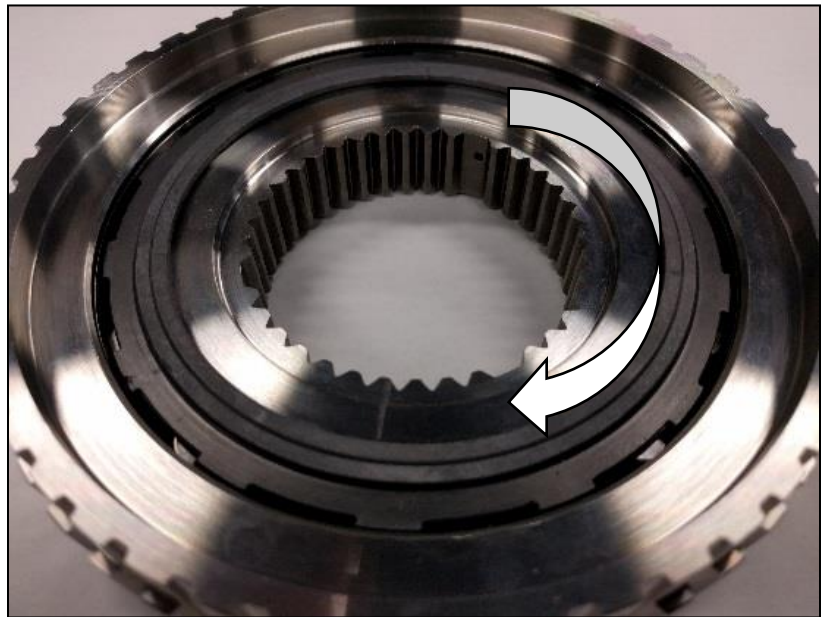

13. Install the 68RFE snap ring to secure the assembly.



To ensure the assembly is correct, the internal sprag should only turn counter-clockwise and no rotation in the opposite direction.



**DOWNLOAD THE LATEST
INSTALL MANUALS AT
www.bddiesel.com**

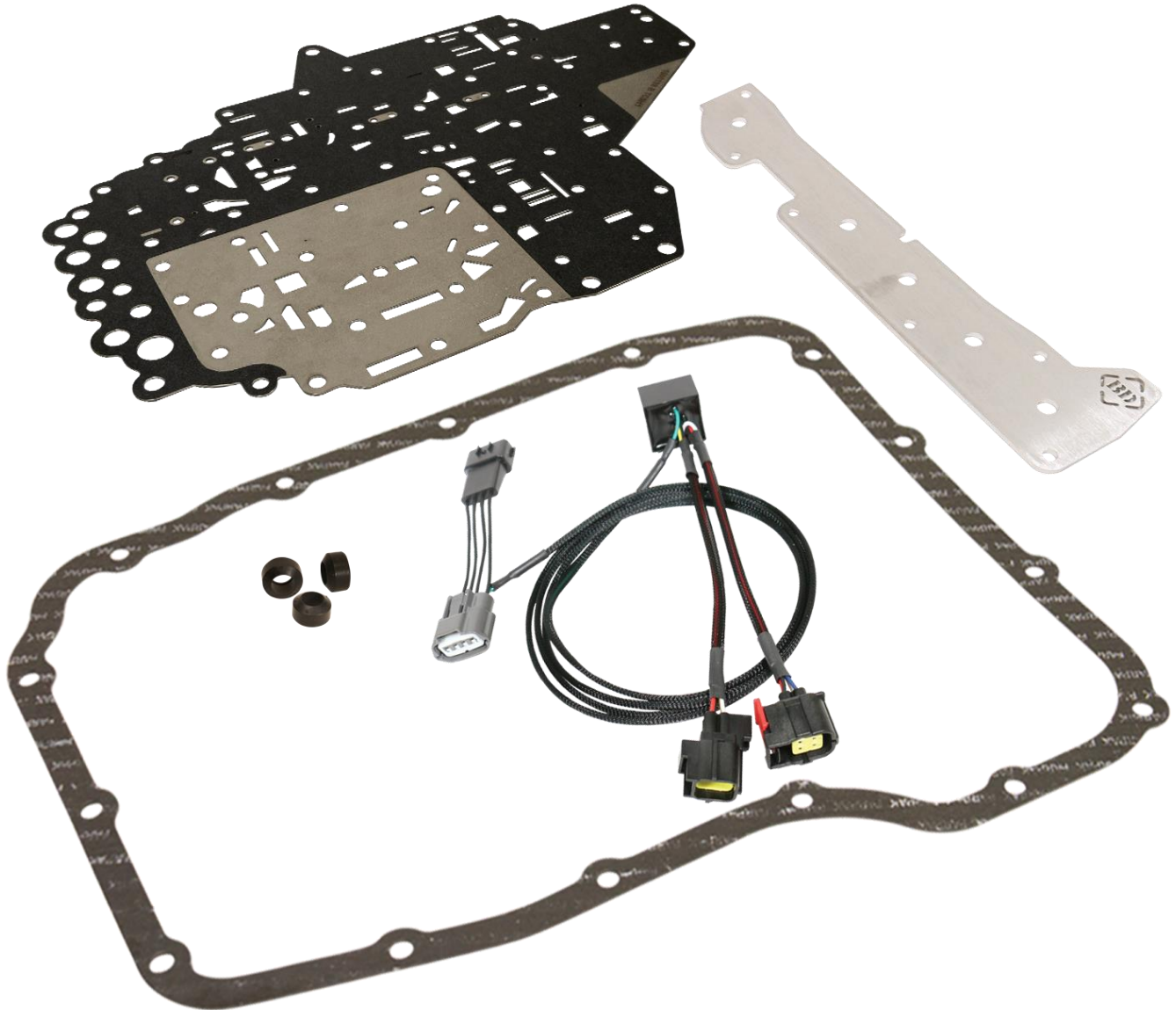

PROTECT68 PRESSURE CONTROL KIT

1030362 2007-2018 68RFE Transmission

PLEASE READ ALL INSTRUCTIONS BEFORE INSTALLATION





DOES NOT FIT 2019+ (BLUE CONNECTOR)

AFTERMARKET TUNERS OR TCMS

If using any aftermarket TCM tuning, the tuner must **NOT** increase mainline pressure. This will conflict with the BD pressure controller which will also increase line pressure. Using both the controller and tuning will set a P0868 fault code and may cause shift issues. Be sure to disable line pressure changes in your tuner or instead order BD 1030373 which does not include the pressure controller.

KIT CONTENTS

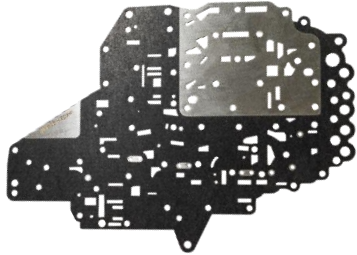
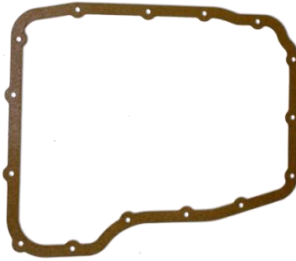
Please check to make sure that you have all the parts listed in this kit.

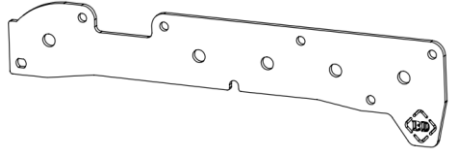
Kit Contents for 1030362		
1030369	4799778	1600186
		
68 RFE Pressure Controller Qty: 1	Clutch Feed Seal Qty: 3	Gasketed; Separator Plate Qty: 1
16001523	52118261	1600205
		
Gasket Qty: 1	Check Ball Qty: 2	Accumulator Plate Qty: 1

Tools Required

- Drain Pan
- Transmission Funnel
- 8mm Socket
- T25 Torx Socket
- Torque Wrench (in/lbs)
- Drill
- 1/8” Drill Bit
- Brake Clean or Parts Cleaner
- Center Punch
- Scraper

Upgrade Options

1030240	Torque Converter
1061525	6.7L HD Transmission Pan
1041220	6.7L Cummins Flex Plate
1061529	Adapter Tool – 68 RFE

Installation Video

Check out our YouTube video for install instructions, tips and critical installation steps.



<https://www.youtube.com/watch?v=fCoeMG2TFU>

Early Model / Late Model Transmission Identification



BD now supplies one kit for all 68RFE transmissions. It is no longer necessary to order a separate kit for early and late model transmissions. Pay attention to the instructions as they have changed.

Valve Body Installation

1. Ensure all kit components are accounted for before installation (including the small check ball!).
2. Disconnect vehicle batteries and secure cables away from batteries.
3. Lift transmission dip stick approx. 6 inches to avoid interference later on.
4. Raise vehicle on vehicle lift. If using a jack, use safety stands and chock wheels.

5. Remove shifter cable from transmission for better access to the main electrical connector.



6. To remove connector, push red tab (1) downwards. Then, press the black tab (2) which will allow the white handle (3) to be rotated downwards, releasing the connector from the transmission.

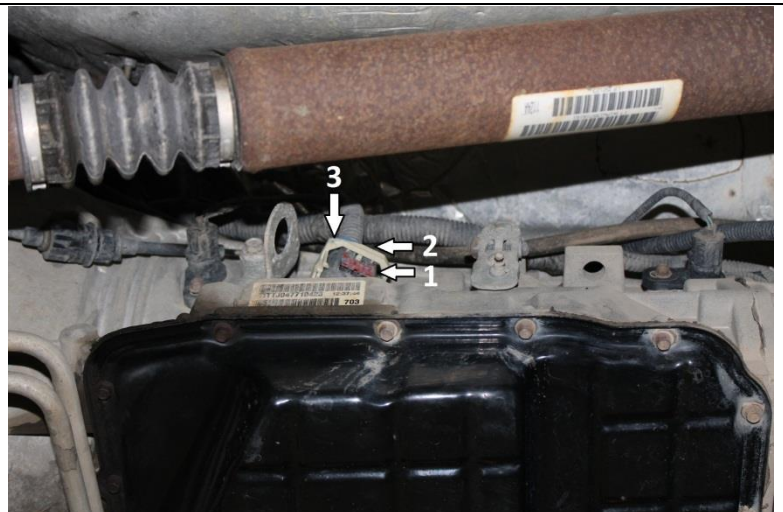

7. Position drain pan below the transmission.

8. Remove 14 of the 15 transmission pan bolts (8mm). Loosen the remaining bolt but leave in place to keep the pan from falling. The transmission cooler lines may need to be moved to access some of the bolts, gently pry them out of the way.



9. Tap pan with a mallet to break the silicone gasket seal. Allow fluid to drain. Remove last screw and drain remainder of fluid.



10. Remove transmission filter by removing the one T25 Torx screw.

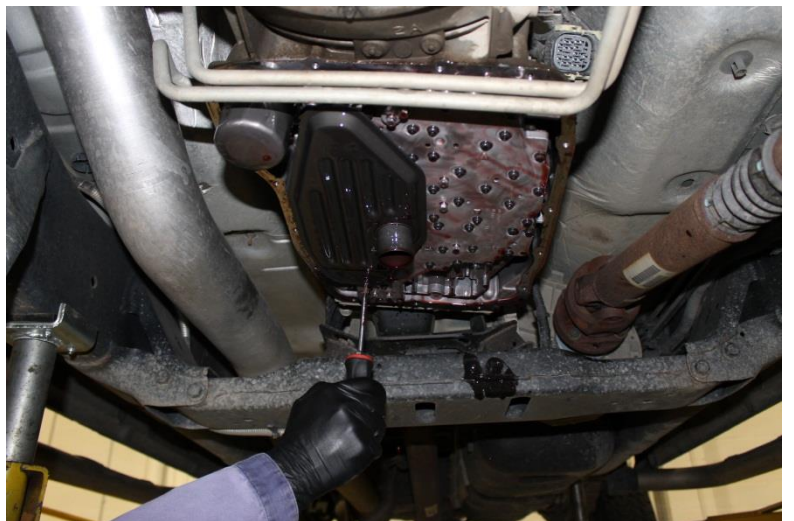

11. Remove the six 8mm bolts securing the valve body to the transmission. Drain valve body of fluid. To remove valve body from transmission, wiggle it while pulling downwards to work the electrical connector through the case.



12. Place the valve body on a clean work surface.

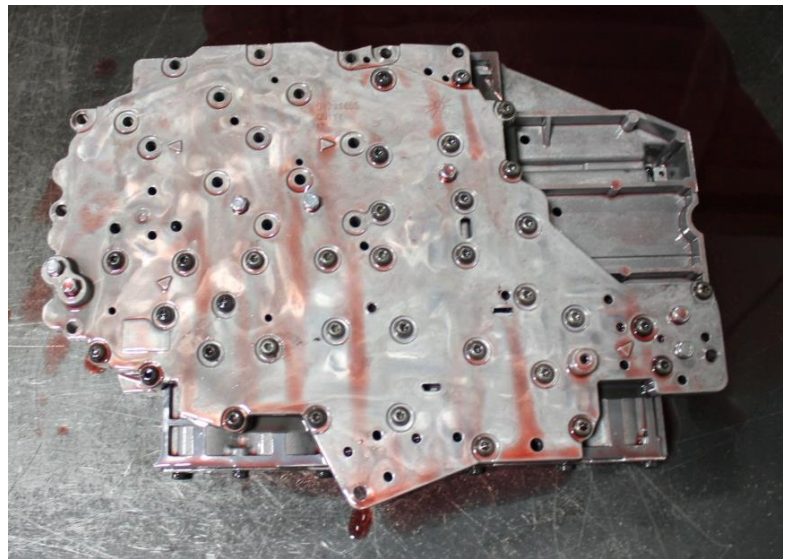

13. Remove fifteen T25 Torx screws securing the solenoid pack to the valve body, remove solenoid pack and place it to the side.

Note: All bolts are the same length.

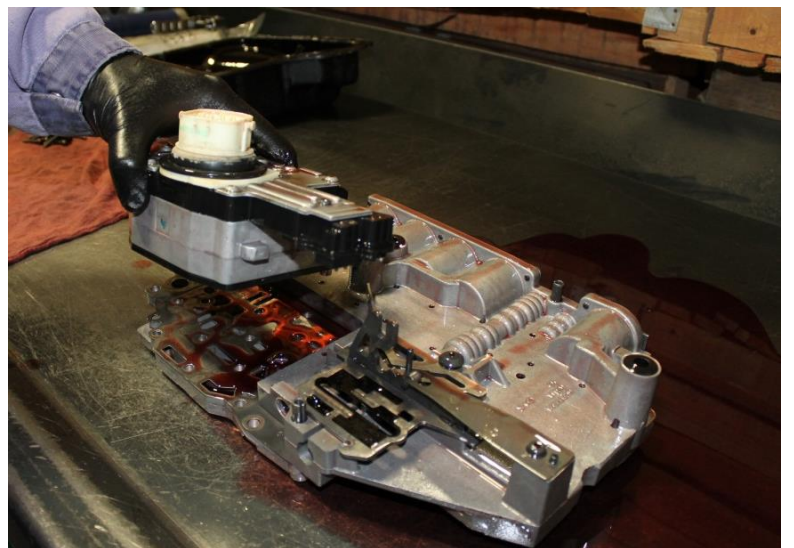

14. Remove remaining thirty-five T25 Torx screws securing the valve body halves.

Note: All bolts are the same length.



15. Carefully separate the two halves of the valve body. Separate as shown in pictures – *do not invert the larger (top) portion as it contains plastic check balls*. The two halves will have to be wiggled apart as the alignment dowels will be holding them together.

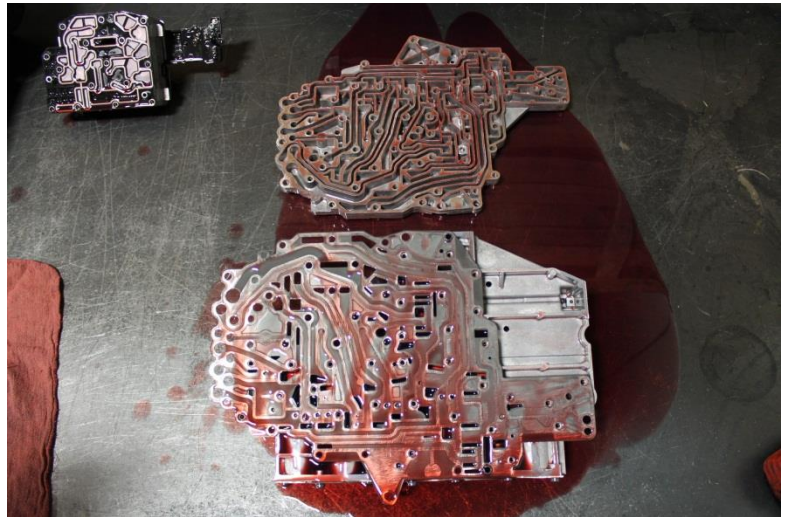

16. Remove old separator plate.

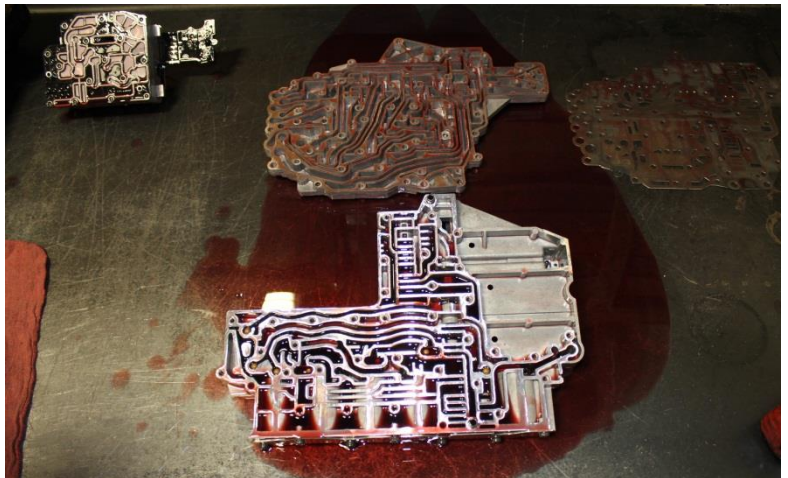

17. Thoroughly clean the bottom (smaller) half of the valve body. Locate the passage to be drilled.

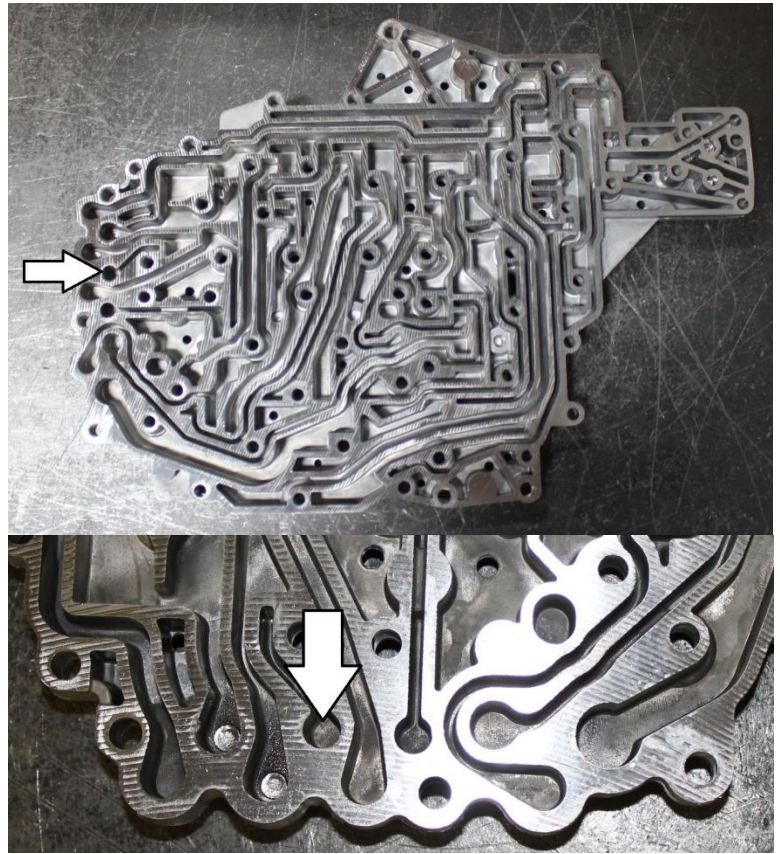

18. Punch center of hole using a center punch.

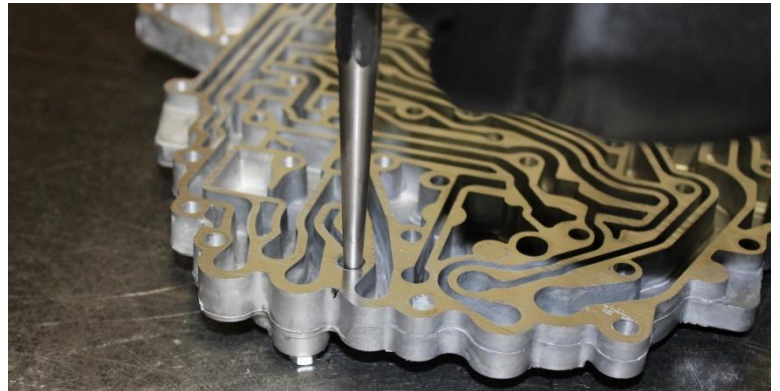

19. Drill hole with 1/8" drill bit.

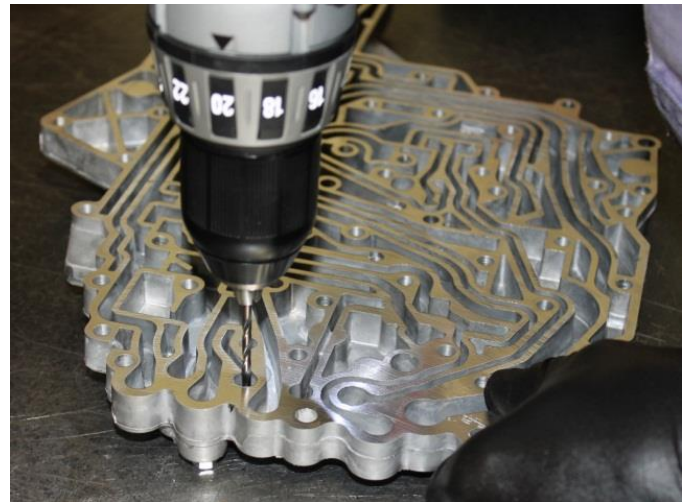



20. Thoroughly remove any burrs and clean all shavings from the valve body. It is imperative that no contaminants are left as they may cause transmission damage.



21. **IMPORTANT!** Ensure that all the check balls are in the locations shown.

If the electrical connector on the valve body is white make sure you have all seven check balls installed.

Discard any extra check balls.

If this part has been contaminated in any way, it must be thoroughly cleaned before reassembly.

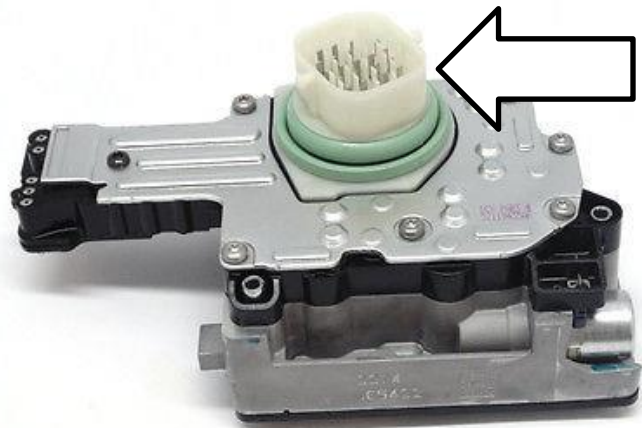

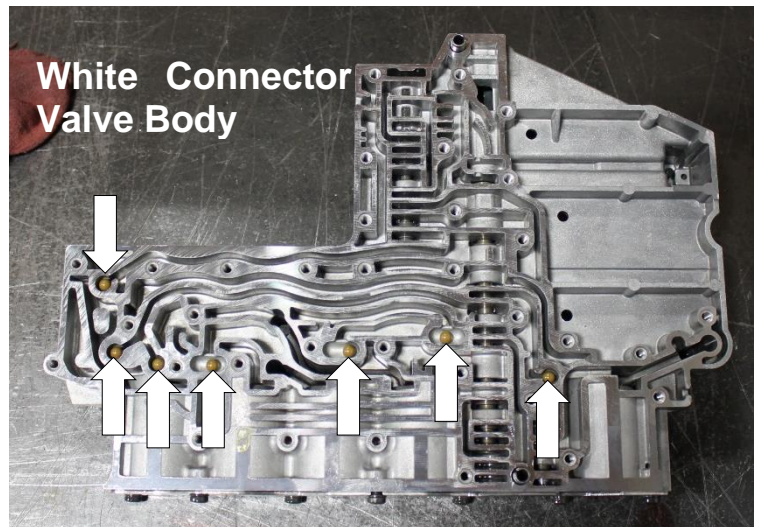

22. IMPORTANT! Ensure that all the check balls are in the locations shown.

If the electrical connector on the valve body is gray you will install six check balls rather than the five that were originally installed.

Use the supplied extra check ball included in this kit for this. Refer to the diagram on the right.

If this part has been contaminated in any way, it must be thoroughly cleaned before reassembly.

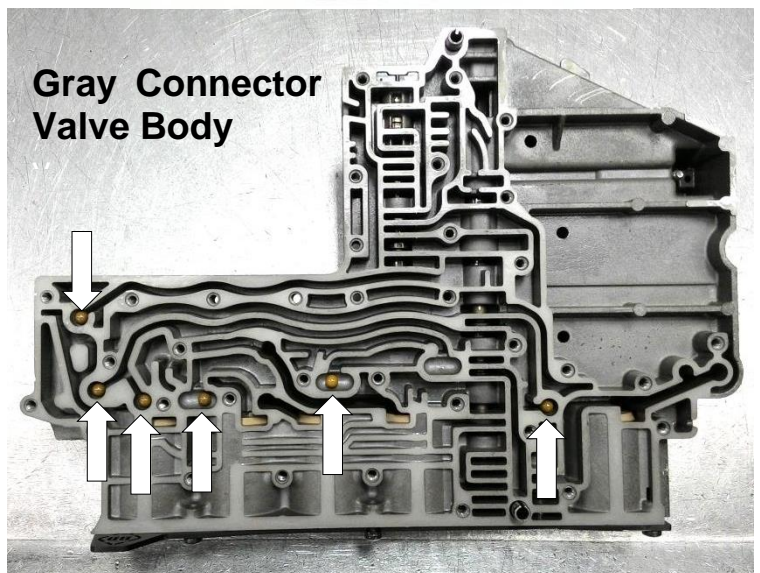
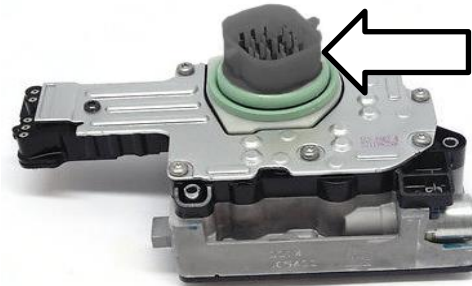

23. Install the BD bonded gasketed separator valve-body plate (1600188).

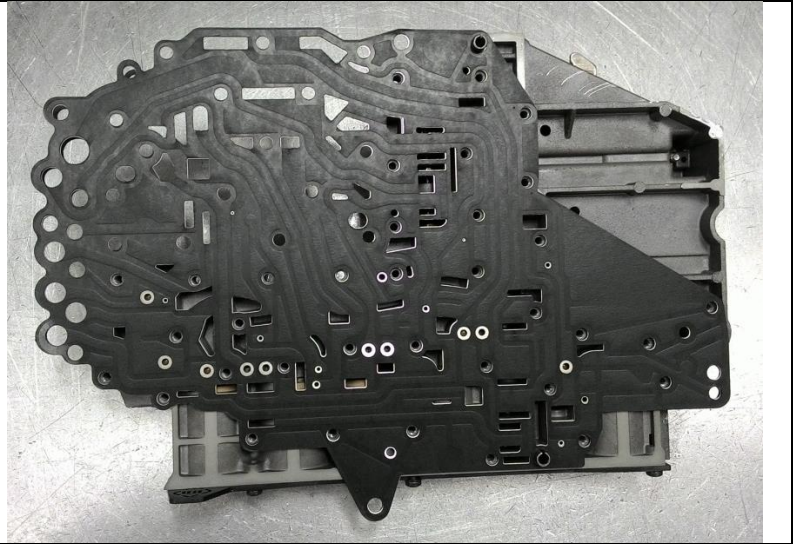

24. Re-install bottom (smaller) half of valve body. Ensure it fits flat on the separator plate/gasket. It may need to be worked downwards while rocking to be installed over the dowels. Install attaching screws so they are fully seated but do not tighten until the solenoid pack has been installed.

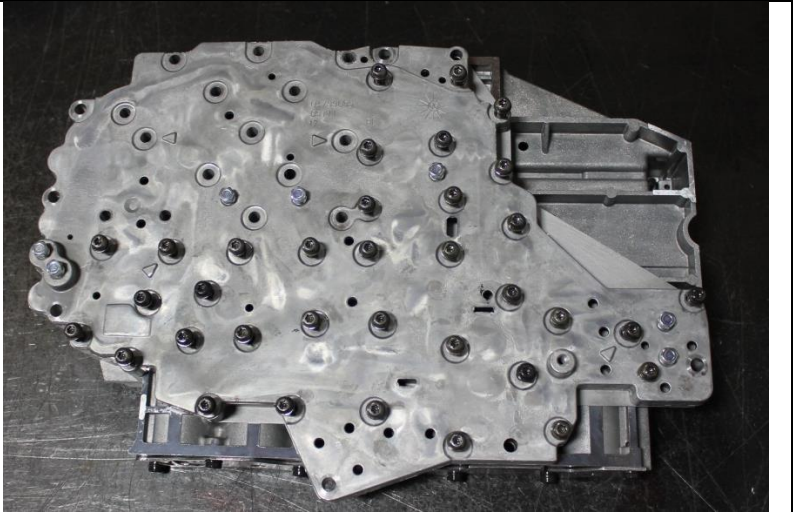

25. Re-install solenoid pack onto valve body. Be sure to properly align the pin on the solenoid pack with the slot on the valve body. Due to the alignment dowels, the valve body may need to be wiggled down into position. Install solenoid pack attaching screws. Install remaining Torx screws to fasten the solenoid pack to the valve body.

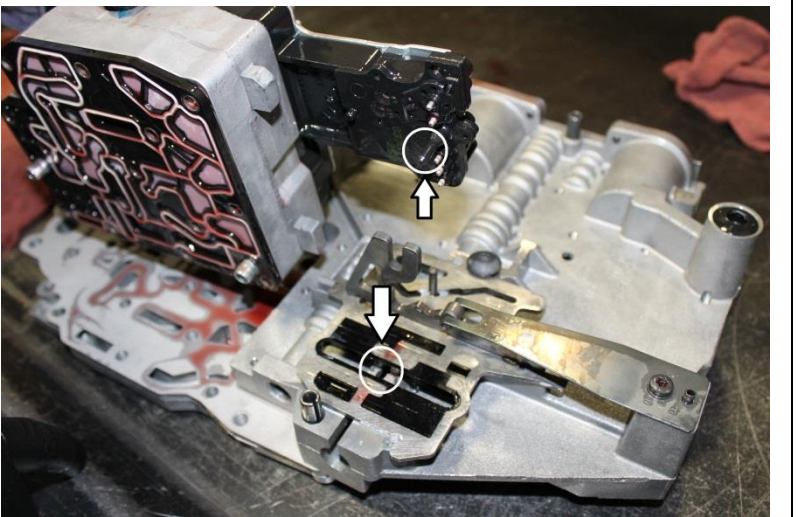

IMPORTANT! – On rare occasions, the solenoid pack gasket comes with a small nub on one side which will need to be removed using a file or blade before installation as the new plate blocks off the opening as it is not present on most applications.

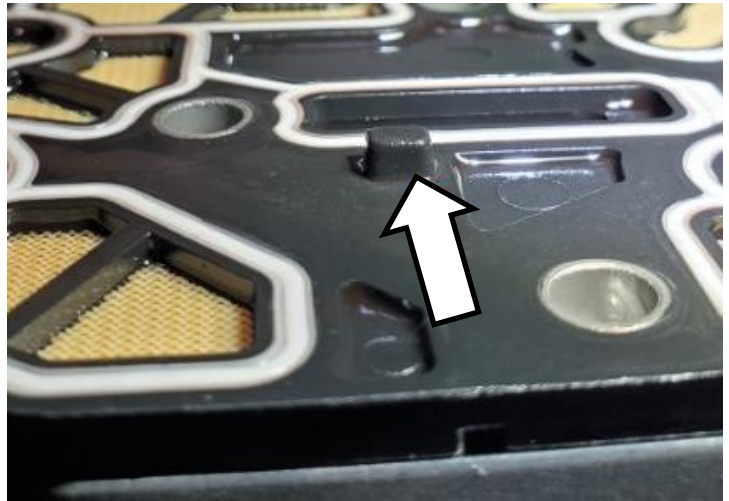

26. Torque all valve body Torx screws to 55 in-lbs, working from the center outwards. Carefully check that no screws were missed.

27. Remove the accumulator retainer plate and reinstall the supplied BD accumulator plate. **Torque screws to 50 in-lb.**

IMPORTANT: Over or under-torquing these fasteners can lead to blown out accumulator plates.

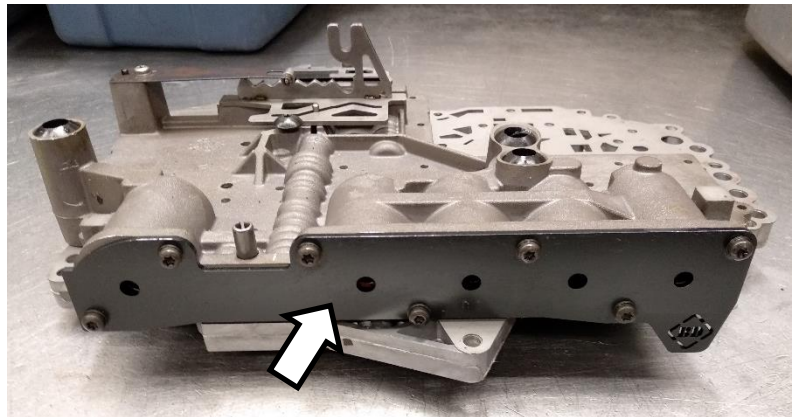

28. Inspect the three rubber seals on the top of the valve body, replace with supplied seals if they are nicked or otherwise damaged. Ensure the seal mating surface on the transmission is clean.

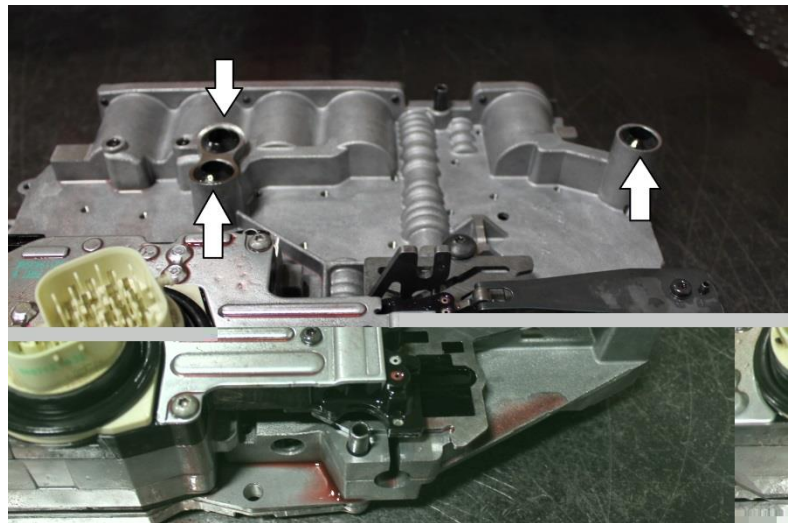

29. Wipe clean the bore on the transmission case around the electrical connector. Scrape all old silicone gasket material (if any) from the oil pan mating surfaces.

30. Check that the shift lever on the valve body lines up with the shift lever on the transmission and lift the valve body back into the transmission. Start the 8mm screws by hand, do not tighten yet. Work the shift lever on the outside of the transmission case by hand to ensure that the lever is making contact with the valve body correctly.

IMPORTANT: Use great care when reinstalling the valve body, the gasket that mates with the front of the case must line up correctly. Do not fold or pinch during installation.

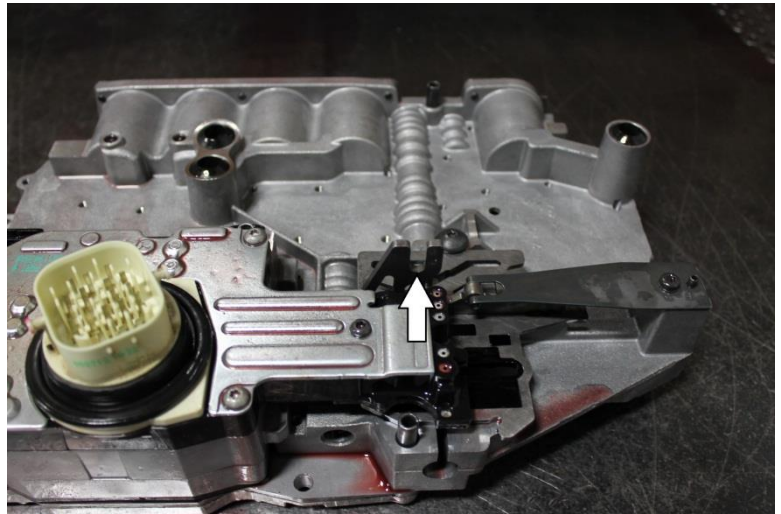

31. Torque the valve body attaching bolts to 105 in/lbs.



32. If desired, install new filter(s). Otherwise, reinstall the filter/pickup assembly. Torque to 50 in/lbs.



33. Place the supplied gasket on the transmission pan. Hold pan below transmission and install attaching screws. Torque the pan screws to 105 in/lbs.



34. Re-attach the transmission main electrical connector. Reattach shifter cable to shift lever.

35. Install the 68RFE pressure module according to the instructions included with it. Until this is installed the transmission will operate at stock line pressure.

IMPORTANT Connect the module to the MAP sensor on the driver's side of the engine NOT to the air intake sensor on the passenger side of the engine.

36. Lower vehicle.

37. Reconnect vehicle batteries.

38. Fill transmission fluid until COLD line is met. Start and run vehicle. Move shifter through different gears twice to fill valve body. Check for leaks. Check fluid level again. Top up as required.

39. Road test. Run through upshifts several times at light throttle to ensure transmission is shifting correctly. Shifts will feel firmer with increased throttle.

40. Recheck fluid level.

41. Note. If you would like to verify the increases in line pressure, use adapter kit (BD 1061529) in conjunction with a 300psi gauge. Pressures at wide open throttle should be between 240 – 260 PSI with a mechanical gauge.

ADAPTER KIT BD# 1061529



Use this kit with a 300 psi gauge.

TECH Bulletin – Protect68 Kit P0871

The protect68 kit is not designed to correct an already damaged transmission. Its purpose is to increase the reliability through increasing torque holding capacity of the transmission by increasing line pressure and eliminating cross leaks in the separator plate.

68RFE transmissions that run increased line pressure without a gasket (like the one included in this kit) may exhibit a P0871 due to cross leaks at the mating surface between the valve body halves. However, if this fault appears even after the installation of the gasket the problem may be a worn-out valve body.

By increasing main line pressure wear in the SSV bore may become more apparent. On high mileage transmissions the SSV valve bore may be worn, causing leakage into the overdrive hydraulic circuit. 2007.5-2009 trucks were highly susceptible to this damage. Model years after and including 2010 have an updated valve body that includes a hard-anodized coating which substantially increases lifespan. A hard-anodized valve body will be a dark gray color due to the coating.

The symptom would be a P0871 DTC (OD Pressure Switch Rationality fault). This DTC would normally be set in gears 1,2,3 at full throttle. If this is the case in which your vehicle has set this code before or after installing the protect68 your valve body has worn. The best solution is to purchase a new (revised) valve body from Chrysler with the hard-anodized coating. An alternative method is to ream the valve bore and install an oversized valve. This will resolve the problem for a while but it will eventually return.

If you would like to repair your valve body, please be aware that it is a difficult repair. Please take the valve body to a machine shop or a very experienced transmission repair facility that has the proper equipment.

You can purchase the repair kit from Sonnax.

Sonnax 92835-32K Oversized Solenoid Switch Valve & Plug Kit

Sonnax F-92835-TL31 Tool Kit (reamer tool)

Sonnax VB-FIX Valve Body Reaming Fixture (not required but recommended)

www.sonax.com



General Policy

All core returns must be,

- like for like, no mixed models
- drained of all fluids (\$50 Charge)
- be returned in the original packaging
- Part Disassembled
- No junkyard cores (core must have been removed from vehicle)
- No fire damage
- Free of excessive Rust or Water Damage

Returned cores that fail to follow the above conditions will be disallowed and scrapped or returned at the customer's expense. Freight and removal damage are not covered. BD Diesel reserves the right to adjudicate cores as it sees fit and may deviate from its policy.

BD FUEL INJECTION CORE ACCEPTANCE POLICY

Model	Deduction	No Credit
P7100 Injection Pump	<ul style="list-style-type: none"> • AFC Housing Damaged (25% Deduction) • Governor Housing Damaged Front or Back (25% Deduction) 	<ul style="list-style-type: none"> • Contaminated/Bio Diesel • Damaged Camshaft on 911/913 pumps. • Main Body Damaged
Bosch VE Pump	<ul style="list-style-type: none"> • AFC Housing Damaged (25% Deduction) • Cold Advanced Housing Damaged (50% Deduction) • Governor housing damaged front or back (25% deduction) • Main Body Damaged (50% Deduction) 	<ul style="list-style-type: none"> • Contaminated/Bio Diesel • Seized Head (Does not turn)
CP3		<ul style="list-style-type: none"> • Contaminated/Bio Diesel • Seized (Does not turn) • Catastrophic Shaft Failure (Frost Plugs Damaged or Missing) • Front Cover Damaged
VP44	<ul style="list-style-type: none"> • Damaged Electronics (50% Deduction) 	<ul style="list-style-type: none"> • Contaminated/Bio Diesel • Seized Head (Does not turn)
Common Rail Injectors	<ul style="list-style-type: none"> • Solenoid melted or destroyed, stretched terminals (25% Deduction) • 5.9/6.7 Broken Solenoid Terminal Divider (No Deduction) 	<ul style="list-style-type: none"> • Contaminated/Bio Diesel • Damaged Body
Mechanical Injectors		<ul style="list-style-type: none"> • Contaminated/Bio Diesel • Damaged Body

BD TURBOCHARGER CORE ACCEPTANCE POLICY

Turbo Model/ Application	Deduction	No Credit
Cummins ISX VGT Air or Electronic Actuated	<ul style="list-style-type: none"> • Damaged Electronics (50% Deduction) • Missing Clamps (25% Deduction) • Missing Parts or Actuators (50% Deduction) • Turbine Wheel Separation (50% Deduction) 	<ul style="list-style-type: none"> • Knock Off Models (Not Genuine) • Part Disassembled
Caterpillar (Ball Bearing) Models		<ul style="list-style-type: none"> • Knock Off Models (Not Genuine) • Wheel Separation
Caterpillar (Standard Turbocharger) 704604-9007, 704604-9011		<ul style="list-style-type: none"> • Knock Off Models (Not Genuine) • Turbo with 3 support Webs

Detroit Diesel VGT	<ul style="list-style-type: none"> • Damaged Electronics (50% Deduction) 	<ul style="list-style-type: none"> • Knock Off Models (Not Genuine) • Wheel Separation
Ford 6.4 Powerstroke	<ul style="list-style-type: none"> • Missing Parts or Actuators (50% Deduction) 	<ul style="list-style-type: none"> • Knock Off Models (Not Genuine) • Part disassembled • Wheel Separation
Ford 6.7 Powerstroke	<ul style="list-style-type: none"> • Missing Parts or Actuators (50% Deduction) 	<ul style="list-style-type: none"> • Wheel Separation
GM 6.6 L5P	<ul style="list-style-type: none"> • L5D Version (due to incorrect compressor cover) (25% Deduction) • Missing Parts or Actuators (50% Deduction) 	<ul style="list-style-type: none"> • Knock Off Models (Not Genuine) • Wheel Separation
Dodge Cummins 6.7 HE351VG/HE300VG	<ul style="list-style-type: none"> • Missing Parts or Actuators (50% Deduction) 	<ul style="list-style-type: none"> • Knock Off Models (Not Genuine)
Standard Turbochargers (All Models, Non VGT)	<ul style="list-style-type: none"> • Damaged Electronics (50% Deduction) • Missing Clamps (25% Deduction) • Missing Parts or Actuators (50% Deduction) 	<ul style="list-style-type: none"> • Knock Off Models (Not Genuine) • Wheel Separation

The above criteria apply to customer core returns. The following criteria will apply for core purchases.

Deduction	No Credit
<ul style="list-style-type: none"> • Cracked or Damaged due to freight • Damaged Electronics • Missing Parts or Actuators • Heavily Damaged Wheels and/or Shaft • Missing Clamps • Turbine Wheel Separation • Heavily Modified Turbochargers 	<ul style="list-style-type: none"> • Knock Off Models (Not Genuine)

BD TRANSMISSION/TORQUE CONVERTOR CORE ACCEPTANCE POLICY

Model	Deduction	No Credit
Transmissions	<ul style="list-style-type: none"> • Cracked Overdrive housings (\$100 Deduction) • 68rfe Cracked Case (25% Deduction) • Part disassembled (50% Deduction) • Missing Transmission Shipping Crate (\$200 Deduction) • Missing TC/Transmission bracket (\$50 Deduction) 	<ul style="list-style-type: none"> • Cracked Case (Except 68rfe)
Torque Convertors	<ul style="list-style-type: none"> • Hub and Impeller damaged. (50% Deduction) 	<ul style="list-style-type: none"> • Excessive corrosion • Part disassembled
Valve Bodies	<ul style="list-style-type: none"> • Missing electronics (25% Deduction) 	<ul style="list-style-type: none"> • Excessive corrosion • Part disassembled

GENERAL CORE ACCEPTANCE POLICY

Model	Deduction	No Credit
EGR Cooler		<ul style="list-style-type: none"> • Brackets broken

Please note that all cores have a time eligibility restriction. Please see BD Terms & Conditions for further details. https://cdn.bddiesel.com/downloads/bd_terms_general.pdf



**DOWNLOAD COLOUR
INSTALL MANUALS AT
www.bddiesel.com**

68RFE Rebuild Kits

Rebuild kits, Build-it parts, & Big Stack kit

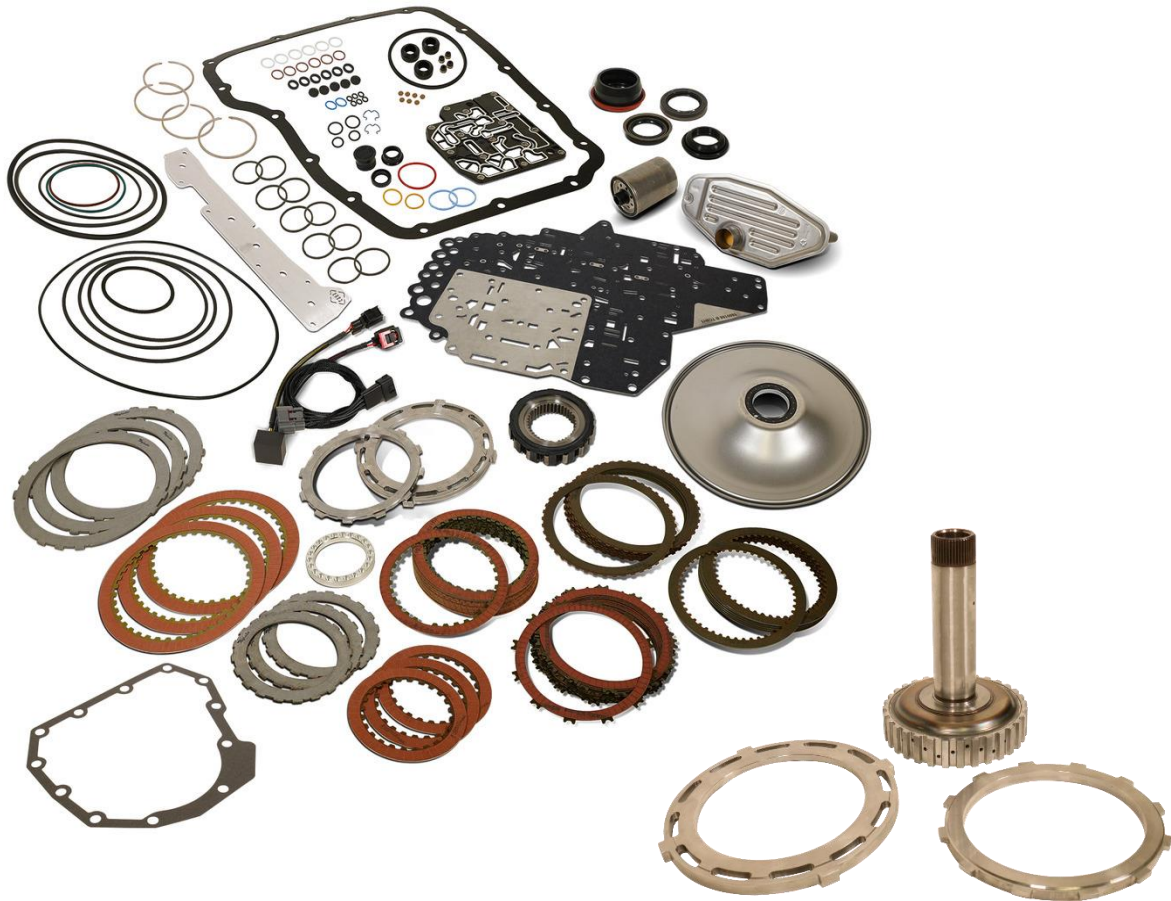

Part #	Description
1062022	2007-2018 68RFE Rebuild Kit – Stage 2
1062023	2007-2018 68RFE Rebuild Kit – Stage 3
1062025	2007-2018 68RFE Rebuild Kit – Stage 4
1062027	2019+ 68RFE Rebuild Kit – Stage 3
1062035	Big Stack Overdrive Shaft & Reaction Plates
1062036	BD Big Stack + Machined Sonnax Drum

Introduction

BD offers a variety of proven 68RFE build-it kits to suite your truck needs. Additional parts/ kits are available should you or your transmission builder want to further increase the performance or durability of your 68RFE.

A transmission learn procedure must be performed should any of the following repairs be applied to the vehicle:

- Transmission Replacement
- Transmission Control Module Replacement (TCM)
- Solenoid Pack Replacement
- Clutch Plate and/or Seal Replacement
- Valve Body Replacement or Recondition
- Torque Converter Replacement
- Battery Replacement
- Power Upgrade or Flash Programmer Installation/ Updates

IMPORTANT! 2019+ valve bodies use an updated solenoid gasket, which must be carefully cleaned, inspected, and reused (Figure 1). If it must be replaced, it is only available with a new solenoid pack.

The 2019+ kit also contains a different Protect 68 Plate Kit, and the check ball that was required in the prior years is no longer required, and is not included.

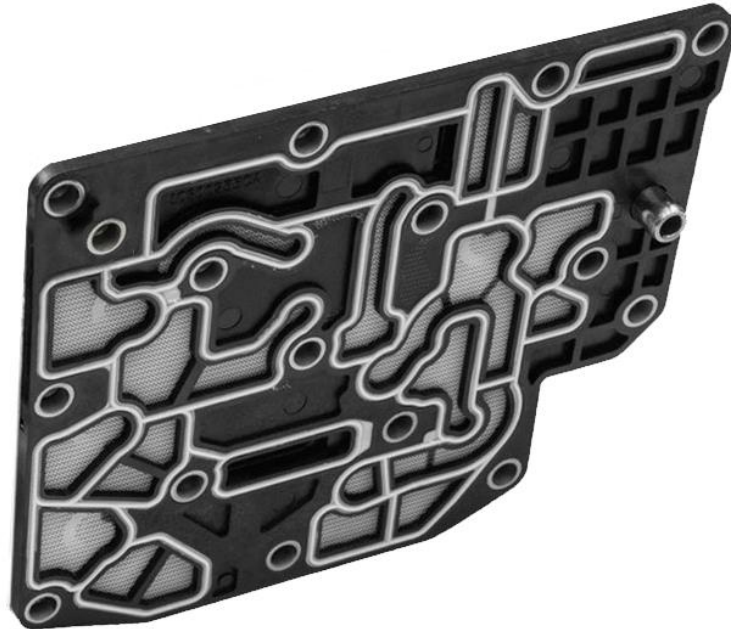

Figure 1. 2019+ Solenoid Gasket

Upgrades/ Individual parts

The below items are available separately and can be purchased individually to customize your transmission build.

BD Part Number	Description
1064043	Filter Kit; Service 68RFE
1030374	Adapter;68rfe Filter Threaded
1030362	68RFE Protect 68 Gasket & Pressure Control
1061525	BD Heavy Duty Transmission Pan
1041221	BD 68RFE Flexplate
1060603	68rfe One Way Clutch/ Sprag
1600189	Billet Input Shaft
1062034	Billet OD Selector Plates (14 frictions)
1062035	“Big Stack” Overdrive shaft + Selector Plates (16 OD frictions)
1062036	“Big Stack” Overdrive shaft + Selector Plates + Large Area OD Drum

2007-2018 Build-it Kit Contents

BD Part Number	Description	1062022 Stage 2	1062023 Stage 3	1062025 Stage 4
K29900L(A)	Gasket and Seal Kit	1	1	1
R600888	2C Friction	3	3	3
29303	2C Steel	3	3	3
B29308L	OD Housing Friction	15	15	15
B29309L	OD Housing Steel	15	15	15
29310	4C Friction	3	3	3
29311	4C Steel	3	3	3
29321L	Rev Friction	7	7	7
29322L	Rev Steel	7	7	7
29601	Filter, Pan	1	1	1
29609	Filter; Spin-on	1	1	1
1600180	4C Spring Retaining Ring	1	1	1
1600163	Selector Plate; OD/Rev (14 OD frictions)	1	1	1
1600162	Selector Plate; UD/ OD (14 OD Frictions)	1	1	1
1030373(B)	Protect 68 Plate kit	1	1	1
1600197	Gasket; 68RFE Ext Housing	1	1	1
52119645AA	Cover; Oil Pump	0	1	1
1060603	Sprag; One way	0	1	1
1030369	Pressure Module	0	0	1

(A)K29900L Gasket and seal kit:

- Gasket; 68rfe Pan (1601523)
- Gasket; 68rfe Solenoid Pack
- Seal; Solenoid Pack Connector
- Seal; 4wd Output Shaft
- Seal; 2wd Output Shaft
- Seal; Input Shaft
- Gasket Kit; Oil Cooler
- Seal Kit; 2-4C
- Seal Kit; Input drum
- O-ring; Pump Cover
- Sealing Kit; Piston rings
- Seal Kit; Solenoid pack
- Seal Kit; Internal valve body and orifices
- Seal Kit; External
- Check Balls; 1/4" - Qty 7

(B)1030373 Protect 68 Plate Kit:

- Bonded Valvebody Gasket Plate
- Heavy Duty Accumulator Plate
- Transmission Pan Gasket
- Clutch Feed Seals
- Check Ball

2019+ Build-it Kit Contents

BD Part Number	Description	1062027 Stage 3
K29901L (A)	Gasket and Seal Kit (2019+)	1
R600888	2C Friction	3
29303	2C Steel	3
B29308L	OD Housing Friction	15
B29309L	OD Housing Steel	15
29310	4C Friction	3
29311	4C Steel	3
29321L	Rev Friction	7
29322L	Rev Steel	7
29601	Filter, Pan	1
29609	Filter; Spin-on	1
1600180	4C Spring Retaining Ring	1
1600163	Selector Plate; OD/Rev (14 OD frictions)	1
1600162	Selector Plate; UD/ OD (14 OD Frictions)	1
1030375 (B)	Protect 68 Plate kit	1
1600197	Gasket; 68RFE Ext Housing	1
52119645AA	Cover; Oil Pump	1
1060603	Sprag; One way	1
1030369	Pressure Module	0

(A)K29901L Gasket and seal kit:

- Gasket; 68rfe Pan (1601523)
- Seal; Solenoid Pack Connector
- Seal; 4wd Output Shaft
- Seal; 2wd Output Shaft
- Seal; Input Shaft
- Gasket Kit; Oil Cooler
- Seal Kit; 2-4C
- Seal Kit; Input drum
- O-ring; Pump Cover
- Sealing Kit; Piston rings
- Seal Kit; Solenoid pack
- Seal Kit; Internal valve body and orifices
- Seal Kit; External
- Check Balls; 1/4" - Qty 7

(B)1030375 Protect 68 Plate Kit:

- Bonded Valvebody Gasket Plate
- Heavy Duty Accumulator Plate
- Transmission Pan Gasket
- Clutch Feed Seals

Installation – 68RFE Rebuild Kit

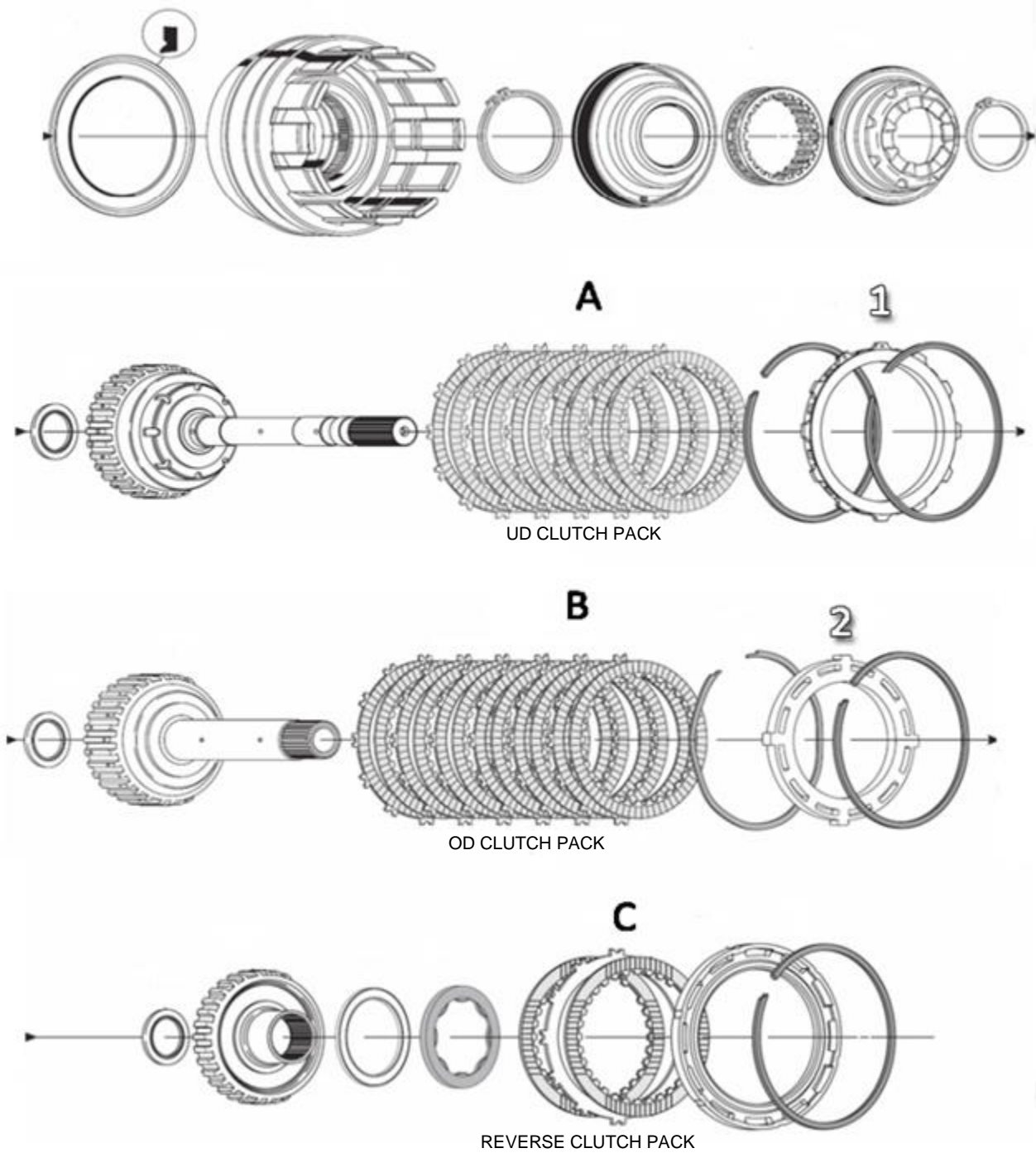

- A – Underdrive Clutch – Use 6+6 of B29308L & B29309L (OEM uses 5+5)
- B – Overdrive Clutch – Use 7+7 B29308L & B29309L (OEM uses 6+6)
- C – Reverse – Use 2+2 of B29308L & B29309L (OEM uses 2+1)
- 1 – UD/OD Pressure Plate #1600162 (can only be installed one way)
- 2 – Rev/OD Pressure Plate #1600163 (can only be installed one way)

68RFE Rebuild Kit – Clutch Assembly (Standard BD Build)

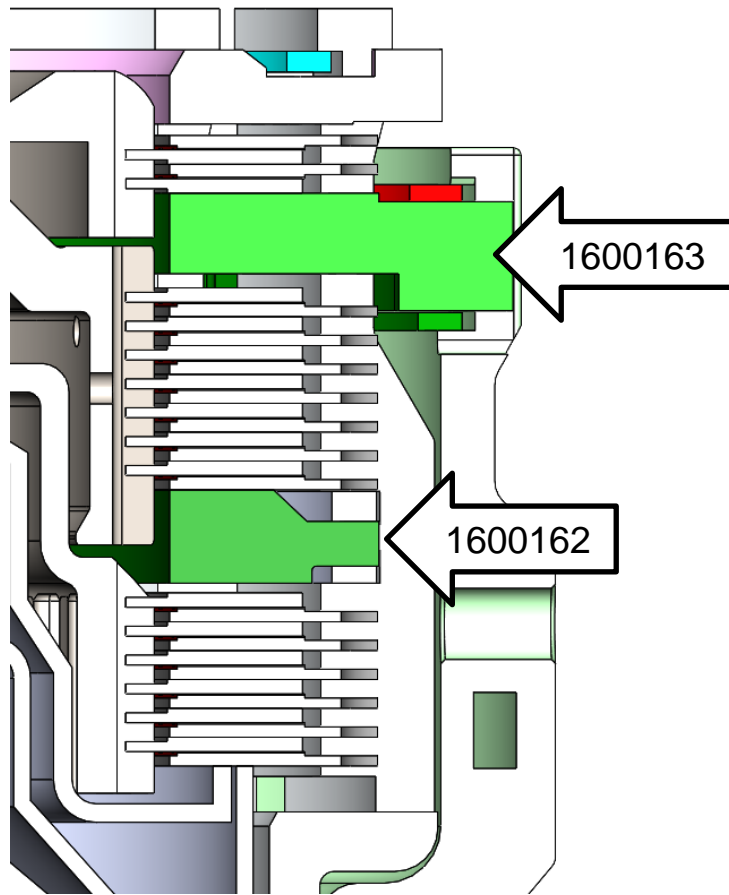

Note 1: The tapered section of the UD/OD pressure plate (1600162) must be facing upward.

Note 2: OEM snap rings MUST be used

Note 3: All UD and OD clutch plates must face upwards

Note 4: Single sided reverse clutches may be oriented either direction

68RFE Clutch Clearance	
Soak all clutches in ATF for 30 minutes before installing and measuring clutch pack clearance	
Underdrive	.040 - .068"
Overdrive*	.030 - .063" *
Reverse	.023 - .058"
L/R	.046 - .082"
4C	.030 - .055"
2C	.038 - .066"

*** 16 friction Big Stack Overdrive kits require different clutch clearances
See Page 9***

1st Gear Sprag

Please be sure to follow the instructions provided with the sprag to ensure correct functionality.

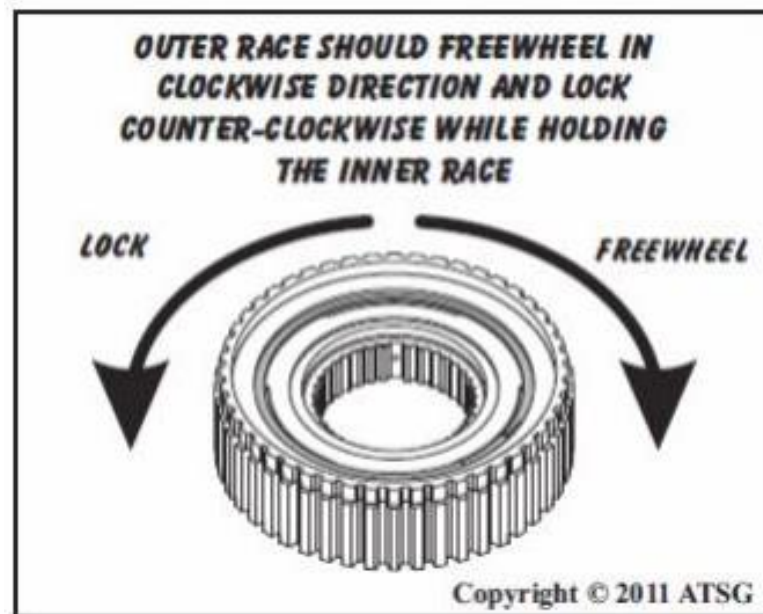

Billet 4C spring retainer

The billet 4C spring retainer (1600180) must be oriented as shown below.

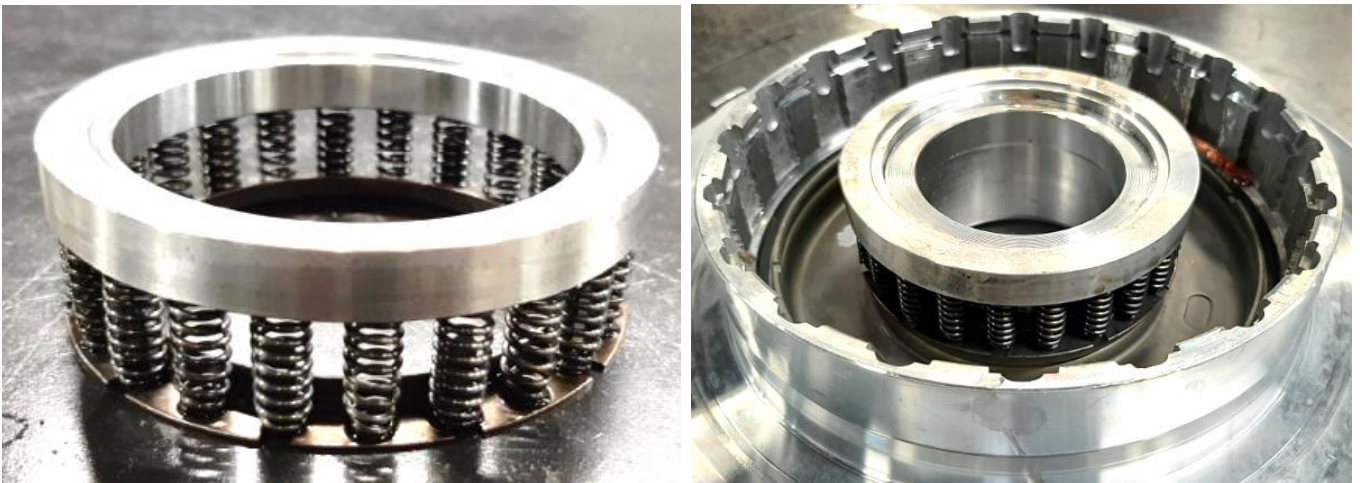



Optional 68RFE Overdrive "Big Stack" Kit

The BD Big Stack uses a different Overdrive shaft and selector plates allowing you to fit 16 overdrive clutches. This made possible with an improved OD shaft with increased spline depth, and two billet QT100 reaction plates. This allows for a 33% increase in mechanical torque holding capacity and a 33% increase in steel thermal mass. The billet QT100 plates reduce clutch coning due to the stiffer material and geometry.





The BD Big Stack can be used in conjunction with a Sonnax input drum to allow a 16% increase in apply area. This setup will allow for a 54% increase in mechanical torque holding capacity. An electronic pressure enhancer (1030369) will further increase OD torque holding capacity.

Kit Components – Big Stack Kits

1062035

1600159	1600178	1600179
		
BD Overdrive Shaft Qty: 1	Reaction Plate; OD/UD Qty: 1	Reaction Plate: OD/Rev Qty: 1

1062036

1600159	1600178
	
BD Overdrive Shaft Qty: 1	Reaction Plate; OD/UD Qty: 1
1600232	M1600233
	
Drum Kit; Sonnax Machined Qty: 1	Machined Bolt-On Plate Qty: 1

*Sonnax Chisel (#1003-80) not included. Use any equivalent 1/8" Chisel.
McMaster Part # 3570A8*

*Clutches not included. To be used with a BD Build-it Transmission Kit
1062023 OR 1062025*

BD Big Stack + OEM Drum Assembly (1032035)

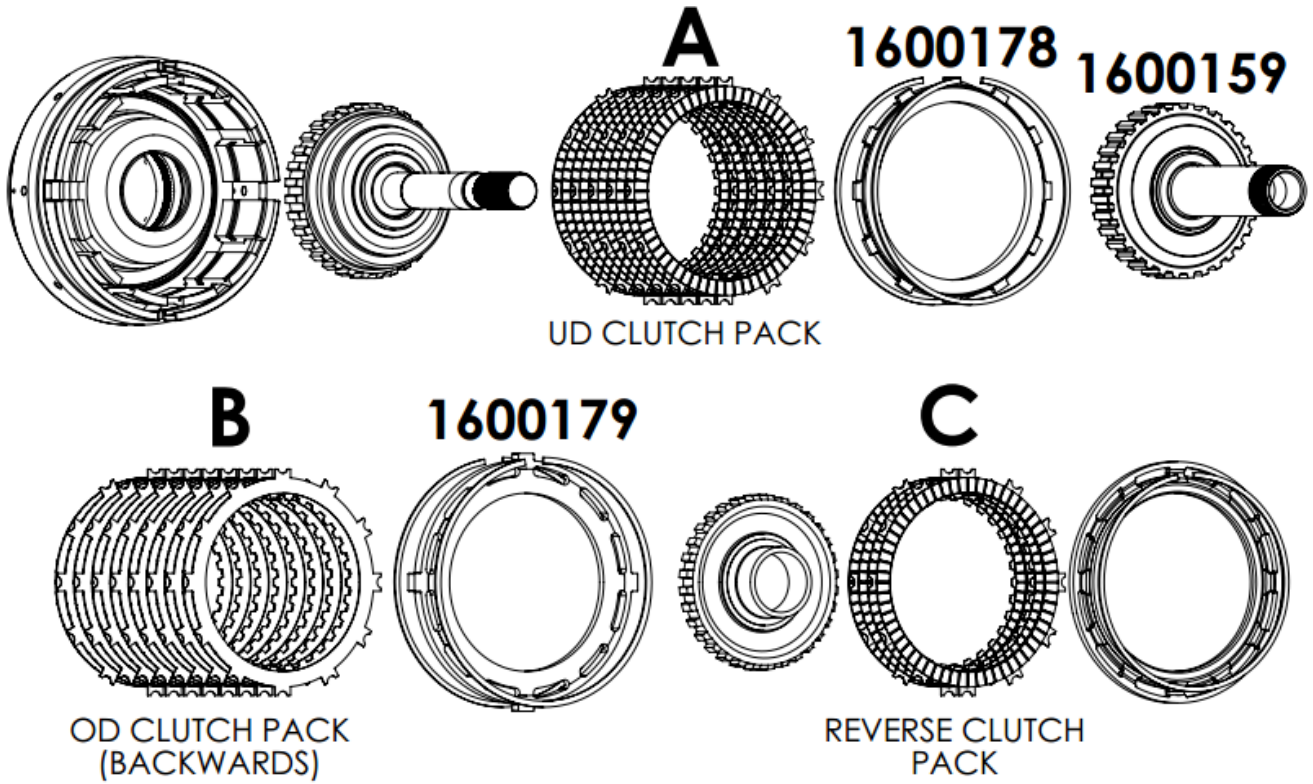

BD Big Stack + Sonnax Drum Assembly (1062036)

See Sonnax PN 72960-06K instructions to assemble the Sonnax drum.

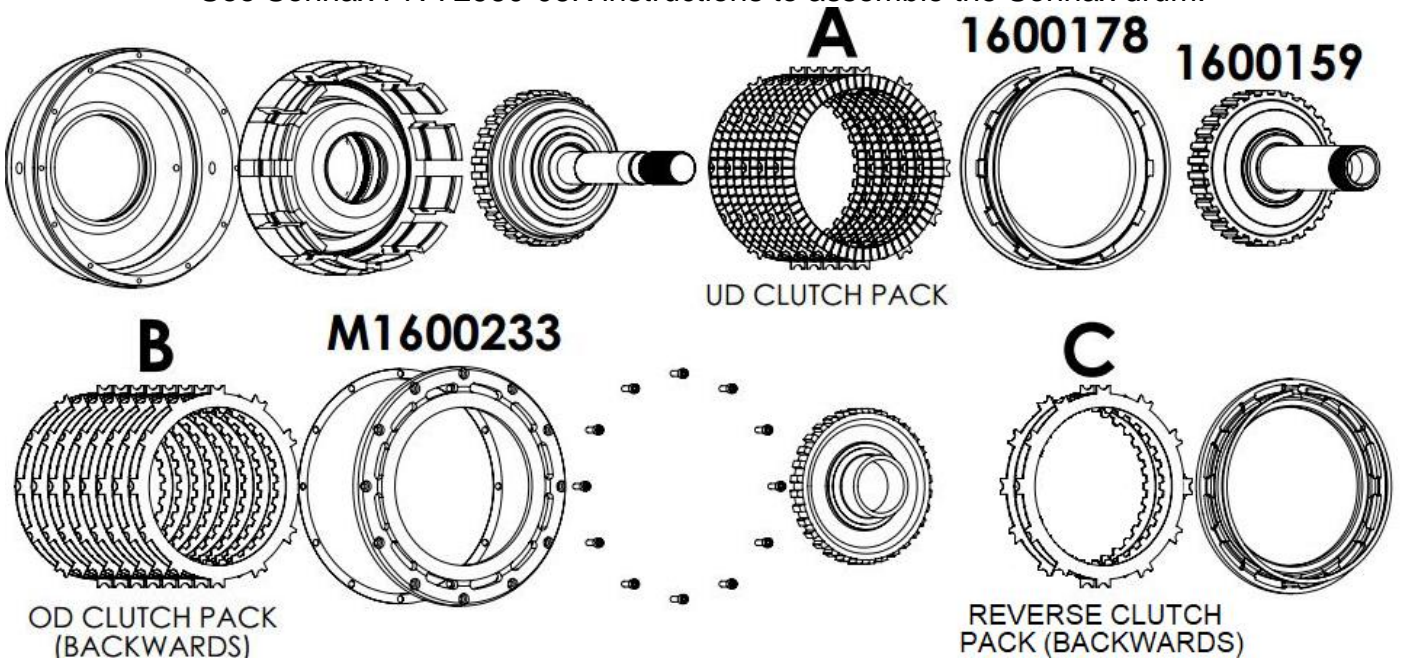

Any purchased kit from BD will have all necessary machining complete. If purchased from a separate vendor, the Sonnax bolt-on plate must be machined to fit the upside-down OD clutch plates. The bolt-on plate does not need to be resurfaced, but the face width must be increased to 6.93" (max tool radius .032").

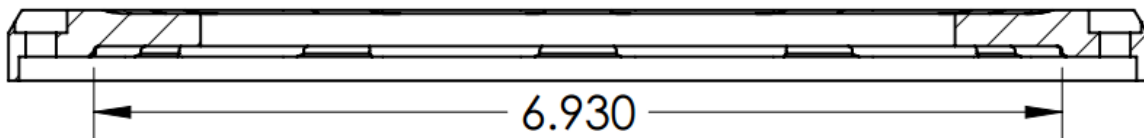

Big Stack Clutch Clearances

Item No.	Description	Clutch Part Number	Clutch Pack Clearance	Quantity
A	Underdrive Clutch Pack	B29308L & B29309L	.040-.068"	5+5
B	Overdrive Clutch Pack	B29308L & B29309L	.040-.055"	8+8
C	Reverse Clutch Pack	B29308L & B29309L	.023-.058"	2+2*

*Replace the OEM 2+1 double sided clutches with single sided 2+2

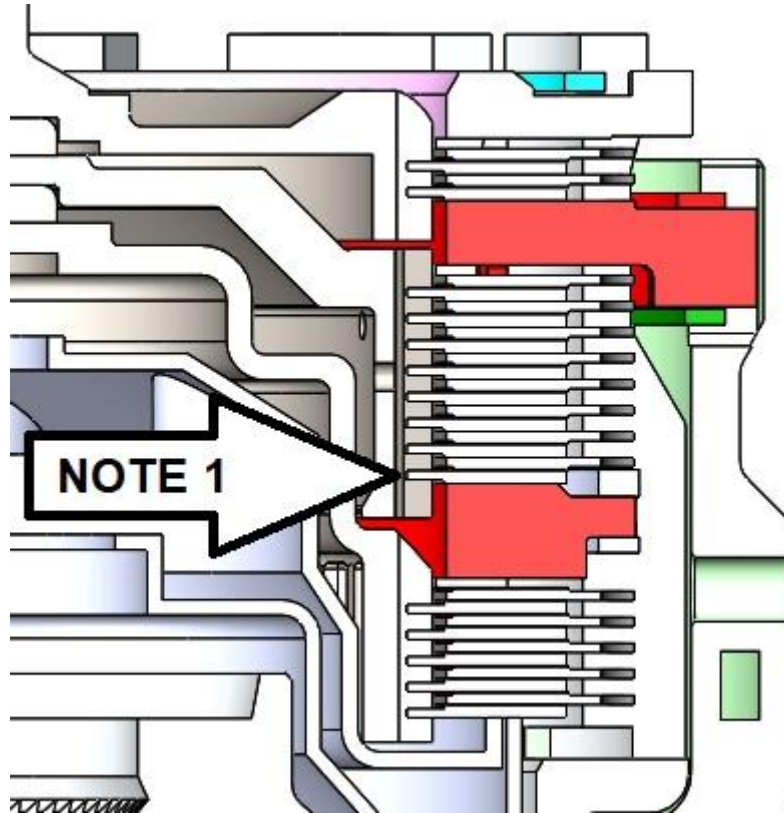

NOTE 1: The OD clutch pack is different than a standard build. The internally splined OD clutch must be installed first with the friction surface facing downward.

Note 2: The tapered section of the OD/UD reaction plate (1600178) must be facing upward.

Note 3: Designed to fit with Borg Warner single sided clutches. Alternate clutches may cause reduced clutch pack clearances which can cause premature failure.

Note 4: OEM snap rings MUST be used

Note 5: The standard Sonnax build will require one Anchor Shim Plate to meet the OD clutch pack clearance requirements.