

**(I-00300)**

**BD Engine Brake LIMITED WARRANTY STATEMENT**

BD Engine Brake (the "Seller") warrants the following product(s):

All products manufactured or rebuilt by the Seller are to be free from defects in material or workmanship, which includes but is not limited to Turbochargers, Exhaust and Intake manifolds, Exhaust brakes, Intercoolers, Flex Plates, Transmissions, Torque Converters, Oil pans, Fuel pumps and systems, Electronic monitors and control systems. The Seller warrants to the original buyer of the product (the "Buyer") that it will repair or replace, free of charge, any product which has a defect in material or workmanship within the warranty period described below. Copy of original invoice is required to qualify for warranty.

A defect is defined as a condition within the product that would render the product inoperable under normal conditions of use and service. The Seller's responsibility under this Warranty is limited to the repair or replacement, at the Seller's option, of any warrantable product returned prepaid with complete service history and proof of purchase. A valid proof of purchase is a dated bill of sale or receipt.

A Return Material Authorization (RMA) number, obtained in advance from a customer service representative of the Seller and the dated bill of sale or receipt, must accompany any product returned by the Buyer for warranty determination. The Seller will be the final authority on the approval of all warranty claims hereunder. The issuance of a RMA number does not represent an approval of a warranty claim. BD reserves the right to return or replace Warranty Approved items freight Prepaid. While warranty denied or rejected, claims will be returned freight collect. Accepted warranty products, which have been replaced, will become the sole property of BD.

Until the Seller has approved a warranty claim, the Buyer will be responsible for all costs. Replacement parts and the labor costs incurred by the removal and replacement of the product while performing warranty work will be the responsibility of the Buyer. In no case does the obligation of the Seller exceed the original purchase price of the product as indicated on the original bill of sale or receipt. Under no circumstances will the Seller be liable for any travel time incurred in diagnosis for defects, or any other contingent expenses.

Only once the claim is approved, and depending on if the warrantable product is eligible, labor costs will be considered for the removal and replacement if an eligible part at an hourly rate of \$100.00 per hour. The end user may be responsible for the difference between the BD warranty labor rate and the authorized service dealer's labor rate. BD recommends the end user negotiate these conditions before the service is performed. As well the end user may be responsible for additional freight charges from FOB Abbotsford, BC / Washington.

To the extent permitted by law, the Buyer hereby waives all rights other than those expressly set out herein and acknowledges that this warranty sets out the Buyer's exclusive remedies with respect to products covered by it. This warranty shall not be extended, amended or varied except by written instrument signed by the Seller and the Buyer. If the buyer replaces the product from the Seller with another from another manufacturer, the Buyer-Seller warranty contract is void and the RMA Claim will be terminated. Any claim for remuneration will be rejected.

The Seller will administer warranty requests on products sold by the Seller and not manufactured by the Seller by forwarding claims made by a Buyer under the manufacturer's warranty to the manufacturer. The final disposition of such claims will be made by the manufacturer and ruled by the laws of British Columbia, Canada.

Customer assumes risk in purchasing product with in 30 days may return the product for exchange of other BD products or services only. No cash refunds are available.

The installation of BD aftermarket parts may void the OE warranty. BD is not responsible for OE warranties or how they are administered. Residents of the U.S.A. can reference the Magnuson-Moss warranty act that protects the consumer on the installation of aftermarket parts, please research this act to base your decisions accordingly.

In the case the warranty is denied, BD at its discretion, may offer to refurbish (where applicable) the product at discounted rate for the end user.

**Please refer to Warranty time limitation per product.**

**NOT COVERED UNDER THIS WARRANTY**

This warranty is limited to the original purchaser of the product and is not transferable to subsequent owners. Specifically excluded from this warranty are failures of products caused by misuse, misapplication, negligence of the Buyer, accidents, modification, abuse, improper storage, installation, repair or operation, use of unauthorized parts or other mistreatment of the Buyer or his agent. Any competitive use, sled pulling, drag racing will void warranty on product. A sheared or twisted shaft, broken planetary gear sets, burned clutches, broken drive hubs, sun gear damage, cracked housings are not covered. Damage caused from debris in oil contaminated coolers, improper fluids and filters or damage caused from fuel or air contamination, Biodiesel, low fluid levels are also not covered. This warranty does not cover deterioration of plating, paint or any other coating, linings or parts that are subject to normal wear and tear, such as light bulbs, fuses, bearing wear, seal wear, etc.

**In the case of BD transmissions, a BD torque convertor must be installed at the time of installation of the transmission. Use of a 3<sup>rd</sup> party or OE convertor may invalidate the transmission warranty.**

If product is not installed by a trained and authorized BD dealer, installation facility must prove it is properly tooled and has certified training to have installed or to carry out repair of product.

The Seller also disclaims any liability for incidental or consequential damages including but not limited to, repair labor, rental vehicles, hotel cost or any other inconvenience cost. To the extent permitted by law, this warranty is in lieu of all other warranties or guarantees, either expressed or implied, included the implied warranties of merchantability and fitness for a particular purpose and shall not extend to any Buyer or to any person other than the original purchaser residing within the boundaries of the continental U.S. or Canada. As well the seller is not responsible or obligated to update previously manufactured parts that are currently under the above warranty.

**NOTE THAT THIS GUARANTEE WILL BE VOID IF THE USER BREACHES THE CONDITIONS IN THE SECTION LABELED "NOT COVERED UNDER THIS WARRANTY" AND IS ONLY APPLICABLE ON THE PRODUCTS THE SELLER MANUFACTURES.**

**DISCLAIMER OF LIABILITY**

Other than as expressly set forth herein, the Seller, together with its distributors, jobbers and dealers shall in no way be responsible for the product's proper use and service. In no event shall the Seller be liable for any special, incidental, indirect or consequential damages of any kind or nature, whether or not the Buyer was advised of the possibility of damage, arising or resulting from the use or performance of the product, and the Buyer hereby waives any and all such claims.

The Buyer acknowledges that he/she/it is not relying on the Seller's skill or judgment to select or furnish goods suitable for any particular purpose and that the Seller has no liability that will extend beyond the scope of the limited warranty contained herein, and the Buyer hereby waives all remedies or liabilities, expressed or implied, arising by operation of law or otherwise, (including, without limitation, any obligations of the Seller with respect to fitness for any particular purpose; merchantability; and special, incidental, indirect or consequential damages) or whether or not occasioned by the Seller's negligence.

The Seller disclaims any warranty and expressly disclaims any liability for personal injury or damages related to the Buyer's use of the product. The Buyer acknowledges and agrees that the disclaimer of any liability for personal injury is a material term for this Agreement and the Buyer agrees to indemnify the Seller and hold the Seller harmless from any claim related to the product and its use or performance. Under no circumstances will the Seller be liable for any damages, liabilities, costs or expenses incurred as a result of by reason of the use, performance or sale of the product, including without limitation, any damages, liabilities, costs or expenses incurred by reason of the Buyer's negligence related to those uses of the product as a result of the removal of the speed limiter.

The Seller assumes no liability regarding the improper installation or misapplication of the product. It is the installer's responsibility to check for proper installation, and, if in doubt, contact the manufacturer.

Limited Warranty Details			
Product Name	Parts (Months/Miles) <sup>1</sup>	Labor (Months/Miles) <sup>1,2</sup>	Notes
Torque Converters	36/ 150,000	12/12,000	No Race abuse covered
Transmissions (TowMaster & TorqueMaster)	36/ 150,000	12/ 24,000	No Race abuse or broken shafts covered. Remote filter required for inspection with a cooler flow rate in GPM at Oil/Air transmission cooler outlet. Freight provision allowed.
Transmissions (RoadMaster)	24/ 100,000	12/ 24,000	
Rebuild/Repair Transmission	12/ 24,000	12/ 24,000	Defined as "Cost of Repair" or repaired units that fall outside of the retail warranty period.
Race Transmissions	12/ 24,000	Not Eligible	
Valve / Accumulators Bodies	12/ 24,000	12/ 24,000	
Transmission Pans	36/ 150,000	Not Eligible	
Flex Plates	36/ 150,000	Not Eligible	
Injectors (Mechanical) & Injection Pumps	12/ 24,000	12/ 24,000	VP44/P7100 Race Pumps 90 days parts/No labor coverage
Performance Injector Nozzles (Common Rail)	Not Eligible	Not Eligible	
Common Rail Injectors	24 Months	Not Eligible	Manufacturing and material defects are only covered. Cracks caused by high fuel pressure are not covered. High Return flow not covered after 12 months on Performance Injectors. For No Hassle Eligibility, see <a href="https://us.bddiesel.com/pages/extended-warranty">https://us.bddiesel.com/pages/extended-warranty</a>
	24 Months + No Hassle	Not Eligible	
Performance Tuners and Chips	Manufacturer <sup>3</sup>	Not Eligible	
BD Electronic Modules (TSB, VVB, etc)	24/ 48,000	Not Eligible	
Intake / Exhaust Manifolds	36/ 75,000	Not Eligible	
Exhaust Up pipes	12/24,000	Not Eligible	Surface rust not eligible.
Exhaust Kits	Manufacturer <sup>3</sup>	Manufacturer <sup>3</sup>	
Hoses / Clamps	12/ 24,000	Not Eligible	
BD Xtruded Transmission Cooler	12/ 24,000	Not Eligible	
Manual Transmission Clutches	Manufacturer <sup>3</sup>	Manufacturer <sup>3</sup>	
Short Shifters	12/ 24,000	Not Eligible	
Engine / Head Stud kits	Manufacturer <sup>3</sup>	Manufacturer <sup>3</sup>	
Positive Air Shutoff / Electronic Positive Air Shutoff	24/ 24,000	Not Eligible	
Exhaust Brakes	24/ 24,000	12/ 24,000	
Gauges and Mounts	Manufacturer <sup>3</sup>	Manufacturer <sup>3</sup>	
Screamer Turbos	24 Months	Not Eligible	24 Month warranty effective for sales after 11/01/2024
Performance/OEM Turbos	12 Months	Not Eligible	
Remanufactured ISX Turbos	90 Days	Not Eligible	See I-00437 for more details. For 1045880, see OEM Turbos.
Auxiliary Fuel Pumps	12/ 12,000	Not Eligible	
BD FICM	12 Months	Not Eligible	
Fuel Control Plate/Pin (VE & P7100)	24 Months	Not Eligible	
Distributed Product (Not Manufactured by BD)	Manufacturer <sup>3</sup>	Manufacturer <sup>3</sup>	
Replacement Components	12 Months	Not Eligible	
Transmission Rebuild/Build It Kits	12 Months	Not Eligible	Material Defects Only
Steering & Suspension Parts (Track Bar, Caster kit, Steering Stabilizer, Bars and links)	Limited Lifetime (12 months if not registered)	Not Eligible	Must register online within 30 days of purchase to be eligible. See website <a href="https://warranty.bddiesel.com/limited-lifetime/">https://warranty.bddiesel.com/limited-lifetime/</a> for details. Excludes normal wear & tear (boots, bushings, joints, bearings) and improper use.
Venom/FlowMAX Fuel Lift Pump Kit	Limited Lifetime (12 months if not registered)	Not Eligible	Must register online within 30 days of purchase to be eligible. See website <a href="https://warranty.bddiesel.com/limited-lifetime/">https://warranty.bddiesel.com/limited-lifetime/</a> for details. Excludes normal wear/service items (hose, filters) and improper use.

A Return Material Authorization (RMA) number, obtained in advance from a customer service representative of the Seller and the dated bill of sale or receipt, must accompany any product returned by the buyer for warranty determination.

<sup>1</sup> Warranty is based on whichever occurs first (Months or Mileage).

<sup>2</sup> Prior approvals must be given to qualify for labor reimbursement.

<sup>3</sup> As per Manufacturer's warranty

Updated 10/21/2024

## CHECKLIST FOR INSTALLING TURBOCHARGERS

1. Inspect the intake and exhaust systems leading to and from the turbocharger to ensure absence of foreign material, including burrs and loose lining fragments.
  - a. Be thorough – even small particles can cause severe rotor damage if inducted during high speed operation.
2. Use new and approved gaskets at the various air, oil and exhaust connections to the turbocharger
  - a. Avoid the use of sealing or jointing compounds at all flanged connections.
3. Use a high temperature anti-seize compound (such as Fel-Pro C5A) on all threaded fasteners connected to the turbocharger.
4. Limit the drain port tilt to 20° from bottom center in either direction.
  - a. Tilting in excess of this amount can create a low-idle leakage tendency at both the turbine and compressor seals.
5. Fill the oil inlet port to overflowing with clean engine oil before connecting the oil feed hose to the turbocharger.
6. If the clamp tabs or V-band are loosened for angular orientation of the compressor cover or turbine housing, be certain that the mating flanges are tightly reseated, and that the fasteners are retightened to the torque levels specified in the appropriate manual.
  - a. Complete the orientation of the cover and housing before making any rigid connections to the compressor inlet and outlet, or to the turbine outlet; this will make certain that all ducting aligns closely with the turbocharger; this will minimize the external stresses acting on the unit.
7. Before connecting the oil drain hose, crank the engine without firing until a steady stream of oil flows from the drain port.
8. Operate the engine at low idle for at least three minutes after completing the installation of any turbocharger. This will prevent oil starvation damage to the bearing system, and will tend to purge any residual contaminants from the bearing housing prior to the unit acceleration.
9. Always change the engine oil and filter when replacing a turbocharger.
10. Replace or clean the air filter.
11. In case of previous failure, inspect CAC for debris. Clean if necessary.

NOTE: Warranty will be denied if the turbocharger is installed on any application not previously approved by BD Diesel Performance.

## General Factors Affecting Turbocharger Service Life

An analysis of turbochargers removed from service indicates that approximately 40% of the troubles are due to foreign material going through either the turbine or the compressor. An additional 40% are due to lubrication failures. The remaining 20% are of a miscellaneous nature.

Some of the foreign material damage is the result of pieces of burned or broken valves and combustion cups going through the exhaust system into the turbine. Other turbine damage is due to casting fins that may break out of the manifolds and ports. Occasionally improperly installed gaskets will permit pieces of gasket to overhang a port and break off into the exhaust system. Damage due to the nuts and washers that are dropped into the exhaust system is also altogether too frequent. Occasionally engine suffer from scuffed and broken pistons. Pieces of these pistons will damage turbine wheels.

Compressor wheel breakage also occurs due to foreign material although not as frequently as turbine wheel damage. Sometimes pieces of the air cleaner will break loose and go through the compressor. There have also been instances where hose connections fail and pieces of rubber or wire reinforcing from the hose gets into the compressor wheel.

Again, carelessness in allowing nuts, bolts and washers to get into the intake system sometimes causes compressor wheel failures.

Lubrication failure may be any one of a number of types. Undersized or plugged oil lines are quite common. It is essential to have an adequate supply of oil at full engine oil pressure for turbocharger bearings. The turbocharger runs at very high speeds and will very quickly overheat with even a momentary failure of oil supply.

The oil supplied to the turbocharger should first pass through a good filter of adequate size so that there is always full oil pressure at the turbocharger bearing. With an adequate supply of clean oil, turbocharger bearing will run for thousands of hours with no measurable wear.

Failure may occur due to extreme exhaust temperatures encountered in excessive altitude operation. Any engine that is operating close to its limits on exhaust temperatures at sea level will have excessive exhaust temperatures when operated at altitudes above 5000 feet.

Altitude operation will cause the turbocharger speed to increase and may cause failures due to over speeding as well as high temperatures unless the engine's fuel system is derated according to the manufacturer's recommendations.

Inlet restrictions due to plugged air cleaners, collapsing hose connections, or undersized air pipes have the effect of reducing the air supply to the engine and result in excessive exhaust temperatures. Both inlet restriction and the excessive altitude operation can cause turbine wheel failures due to excess temperatures.

With any turbocharger, it is possible to accumulate enough dirt in compressor housing and diffuser to reduce the airflow capacity and the efficiency of the compressor if air cleaning system is not maintained. Reduced air flow will cause the engine to run hotter and may result in burned valves and pistons which in turn will cause turbocharger failure.

Leaking gaskets or connections on either the intake or exhaust system of the engine will cause a reduction in the air supply to the engine and will result in high exhaust temperatures.

Sometimes air connections and exhaust connections are made in such a manner that thermal expansion of the exhaust manifold and other parts connected to the turbocharger will produce very high loads on the turbocharger. These high loads result in housing distortions that cause the compressor and turbine wheels to rub.

Excessively heavy piping that is supported only by the turbocharger may also cause distortion.

Turbocharger mounting that are not sufficiently rigid to prevent excessive vibrations in the turbocharger can also cause distortions and failures.

In conclusion it can be stated that every few turbocharger failures would occur if no foreign material were permitted to enter either the turbine or the compressor; if precautions were taken to prevent excessive exhaust temperatures, and if the turbocharger were always supplied with an adequate amount of clean oil.

# IMPORTANT SAFEGUARDS

## WARNING:

Misuse or modification of the turbocharger can result in serious injury and property damage. Basic safety precautions including the following should always be followed.

1. Read and comply with all instructions including “Checklist for Installing Turbochargers” before installing or using turbochargers. Read “General Factor Affecting Turbocharger Service Life”. (Contact BD Diesel Performance for any additional copies).
2. Install turbocharger only on an engine which has been approved for such application (check BD Diesel Performance Catalog). The turbocharger is a precision built product which has been matched and test for the intended application.
3. Do not modify or substitute any parts of turbocharger. Do not remove metal from any part of the turbocharger.
4. Disassembly and reassembly should done only in accordance with the appropriate set of the instructions provided with the turbocharger.
5. Do not modify or substitute any parts of the engine except in accordance with the engine owner’s manual. Do not modify engine fuel control system or restrict exhaust system or inlet excessively.
6. Do not operate at excessive altitudes (consult engine owner’s manual for altitude restrictions).
7. Be sure that oil supply and drain line are adequate (see “Check List for Installing Turbochargers”).
8. Always warm up engine for 2-5 minutes to allow oil to reach the turbocharger before operating under load.
9. Performance all maintenance specified by the engine manufacturer each time or at intervals maintenance is recommended by the engine manufacturer. Concurrently inspect turbocharger for any deficiencies described in the “General Factors Affecting Turbocharger Service Life”, and correct all observed or suspected deficiencies before operating the engine and/or turbocharger.
10. SAVE THIS LIST OF IMPORANT SAFEGUARDS, THE ENGINE OWNER’S MANUAL, “CHECKLIST FOR INSTALLING TURBOCHARGER”, AND “GENERAL FACTORS AFFECTING TURBOCHARGER SERVICE LIFE”.



**DOWNLOAD THE LATEST  
INSTALL MANUALS AT  
[www.bddiesel.com](http://www.bddiesel.com)**



## **BD Ford Turbo Retrofit**

**Fit a factory-based 2017+ turbo into 2011-2014 models**

<b>Part #</b>	<b>Turbo</b>	<b>Compressor Size</b>	<b>Max Airflow</b>
<b>1045824</b>	<b>Ford OEM 17+</b>	<b>61 mm</b>	<b>66 lb/min</b>
<b>1045825</b>	<b>BD Screamer</b>	<b>64 mm</b>	<b>81 lb/min</b>

An emissions compliant engine calibration must be used.

Edge CTS Evolution is recommended for 1045824  
PPEI tuning for a 15+ turbo is recommended for 1045825

Incorrect engine calibration will cause the truck to enter a de-rated fuel mode

## ***Introduction***

The BD Ford Turbo Retrofit allows you to install a larger GT37 based turbocharger from the 2017+ 6.7L trucks onto a vehicle that originally came equipped with the smaller GT32 SST “DualBoost” or standard GT32 without the need for additional parts.

This will fit 2011-2014 pickups and 2011-2016 Cab & Chassis trucks. 2015 and 2016 models may have some engine overlap, check your specific vehicle prior to ordering.

This pre-assembled turbo utilizes BD exclusive compressor housing, turbine housing, and pedestal specifically designed to fit the OEM based GT37 in the factory location. The original factory intake, hot-pipes, downpipe, exhaust manifold, heat shield, and turbo outlet pipe are re-used and do not need to be replaced.

## ***Pre-Installation Inspection***

When replacing a turbocharger BD recommends the following precautions are taken:



- Replace or clean the air filter.
- Change the engine oil and filter.
- Inspect Intake and CAC passages for debris, and clean if necessary.





In the case of a previous failure also include the following steps:



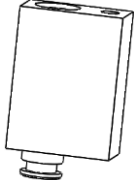

- Inspect CAC for debris and cleanout if necessary.
- Inspect engine oil for debris. Flush system if debris was present.

Ensuring that these steps are followed will prolong the life of your new turbocharger.

## Kit Contents

1045824	1045825	FC3Z-9U469-B
		
Turbo; BD Retro Qty: 1	Turbo; BD Retro Screamer Qty: 1	Tube; Water outlet Qty: 1

1515950	BC3Z-6587-A	1405827	1407079	FT-0135928
				
Harness; Wastegate Solenoid Qty: 1	Gasket; Pedestal Qty: 1	Spacer; Coolant Qty: 1	O-ring; #110 Qty: 1	Bolt; M6-1 x 65mm Qty: 1

1405858	1405829	1900068	FT-0427640	FT-0427642
				
Boot; 3.35"x4" Qty: 1	Boot; Intake Pickup Cap Qty: 1	Cap; 3/16" Qty: 1	Clamp; 2.75"-3.75" Qty: 2	Clamp; 3.5"-4.5" Qty: 1

# Turbo Options

## The OEM Problem:

The 2011-2014 Powerstroke 6.7L offered two different turbo's; one for the pickup truck and one for the cab & chassis. The cab & chassis offered a traditional-style 53mm compressor wheel with a 59mm turbine wheel. A Single Sequential Turbocharger (SST) allowed a single turbine wheel to be paired with two 44mm compressor wheels manufactured together as one. Both of these turbos offer unrivaled turbo response due to their petite GT32 turbo size, however the moment you increase the engine output, restrict the turbo intake, or tow heavy loads, the factory GT32 turbocharger becomes consumable.

## The Solution:

For the majority of owners, Ford included the solution on the 2015+ Powerstroke, a larger traditional-style GT37 VGT. To retrofit this Ford solution onto the 2011-2014 trucks, it requires both the turbo and a list of mating parts to be replaced. BD now offers a solution that lets you fit a large GT37 turbo on your 2011-2014 truck without the need to replace excess components. BD also offers a Ford 6.7L Screamer Turbo Retrofit for those wanting to further increase their trucks airflow potential.

<b>Ford 6.7L Turbo Selection</b>								
Model Year	<b>Pickup (Wide Frame)</b>				<b>Cab &amp; Chassis (Narrow Frame)</b>			
	Stock Replacement	Performance Upgrade			Stock Replacement	Performance Upgrade		
		Retro GT37	Retro GT37 Screamer	GT37 Screamer		Retro GT37	Retro GT37 Screamer	GT37 Screamer
<b>2011</b>	851824-5001	1045824	1045825		854572-5001s	1045824	1045825	
<b>2012</b>	851824-5001	1045824	1045825		854572-5001s	1045824	1045825	
<b>2013</b>	851824-5001	1045824	1045825		854572-5001s	1045824	1045825	
<b>2014</b>	851824-5001	1045824	1045825		854572-5001s	1045824	1045825	
<b>2015</b>				1045828	854572-5001s	1045824	1045825	
<b>2016</b>				1045828	854572-5001s	1045824	1045825	
<b>2017</b>	888143-5001s			1045827	888142-5001s			1045827
<b>2018</b>	888143-5001s			1045827	888142-5001s			1045827
<b>2019</b>	888143-5001s			1045827	888142-5001s			1045827

## **PRE-INSTALLATION**

A new turbocharger will not solve the following failures:

- Oil contamination
- Restrictive oil drain
- Over speed due to a boost leak
- Exhaust leaks due to faulty bellows, clamps, or seals

Turbo over speed will lead to premature turbo failure. Boost pressure can be used to estimate turbo speed. The table below shows maximum allowable turbo speed for a stock motor at 3500rpm. A turbo intake restriction, clogged filter, high altitude or boost leak will cause increased wheel speed.

Turbo	Estimated Airflow (lb/min)	Max Wheel speed (rpm)	Max boost (psi)	Max Boost with clogged filter (psi)
OE GT37	66	121,000	33	30
BD Screamer	81	121,000	39	36

## **PRE-INSTALLATION NOTES:**

- 1) During the repair or install of components, cap, tape or otherwise appropriately protect all openings and tubes / fittings to prevent ingress of dirt or other contamination. Remove caps, tape and other protective materials prior to installation.
- 2) Special attention needs to be given to the sealing ports for the oil feed, the oil drain, and coolant lines on turbocharged engines. The sealing ports must be totally clean and free from O-ring residue, have no damage to the sealing surface and the lines to ensure that there are no leaks or repeat repairs.
- 3) Upon completing a turbocharger replacement, turn the motor over without starting engine to ensure oil pressure is present. Turbocharger journal bearings are highly susceptible to failure if run without a sufficient, steady, and clean oil supply for any amount of time.

## **Removal**

1. Safely secure the vehicle, remove the front right wheel, and disconnect the battery ground cable.

Drain the coolant system.

2. Remove the upper intake manifold.

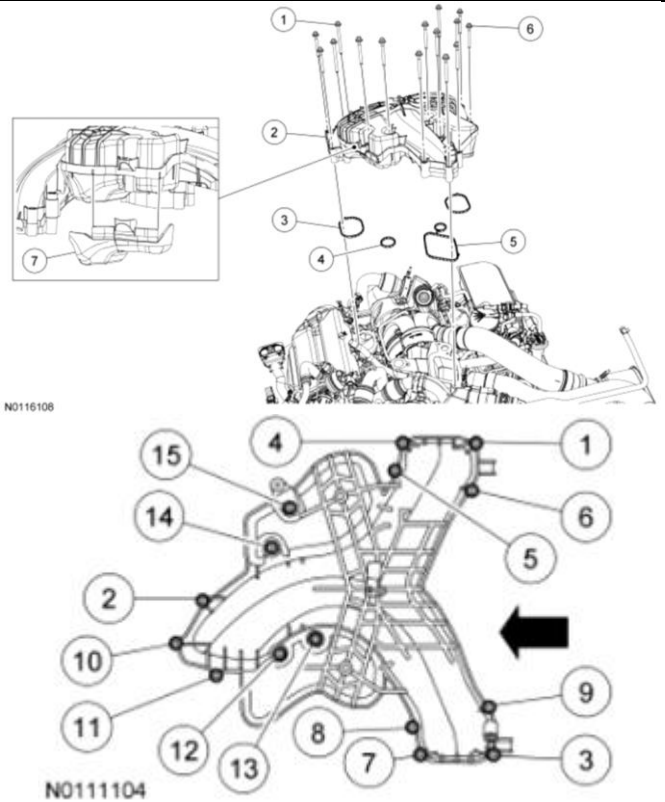

3. Remove the lower intake manifold.

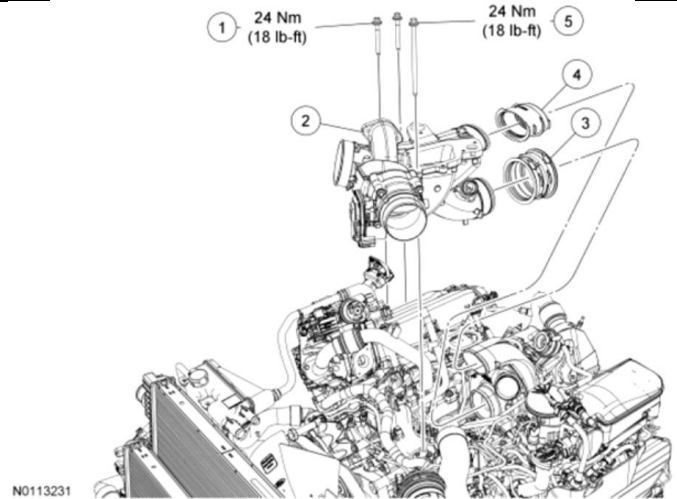

4. Remove the Charge Air Cooler tube.

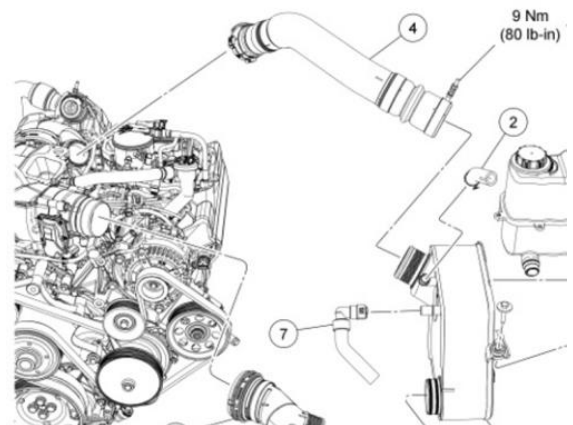

5. Disconnect the turbocharger actuator electrical connector and disconnect the wastegate actuator vacuum hose on pickup models.

Cap the shown location where the wastegate actuator solenoid was fed using the supplied Rubber bullet cap (1900068).

Note: Cab and Chassis models will not need to disconnect the wastegate actuator hose.



6. Remove the turbocharger coolant outlet tube.

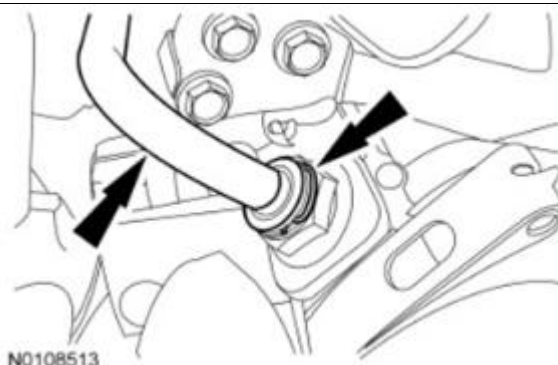

N0108513

7. Loosen the exhaust lower downpipe bolts.

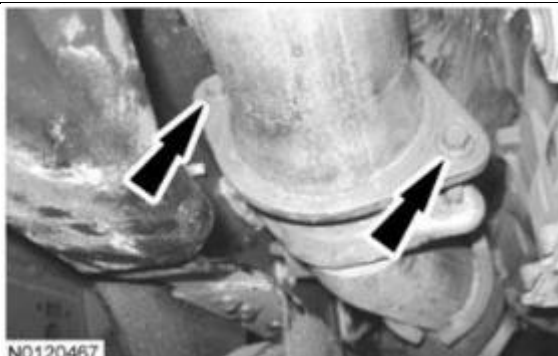

N0120467

8. Loosen the exhaust upper downpipe v-band clamp.

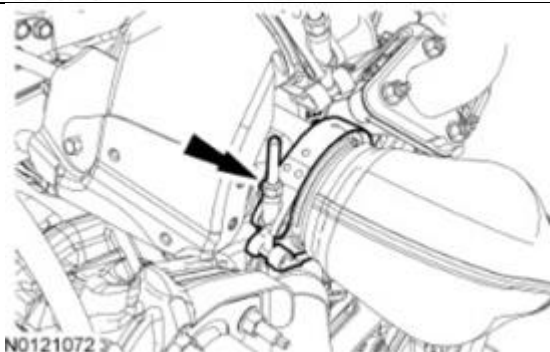

N0121072

9. Loosen the exhaust upper downpipe bracket bolt.

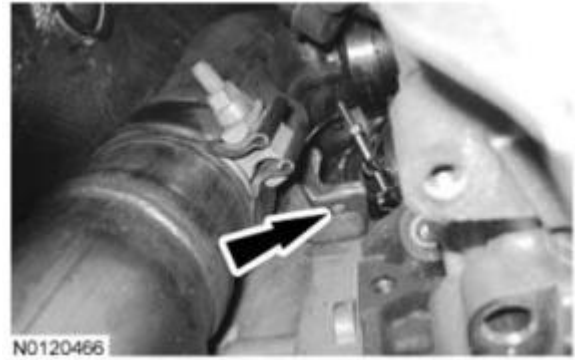

10. Unbolt both turbocharger exhaust hot-pipe v-band clamps.

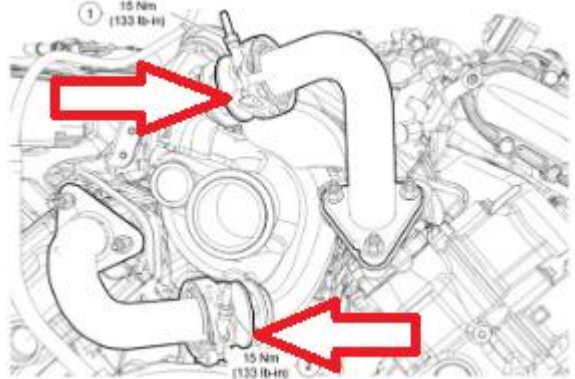

11. Unbolt and remove the four turbocharger mounting bolts.

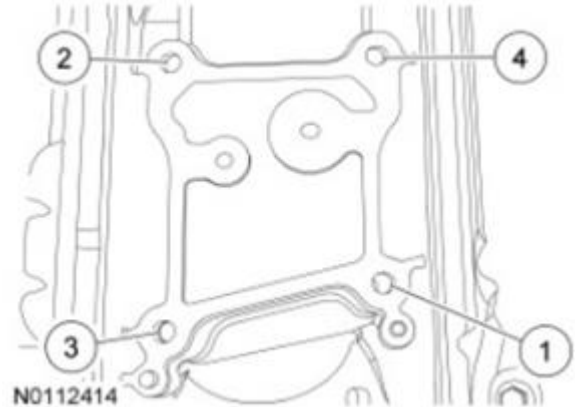

12. Remove turbocharger.  
Keep OEM heat shield.

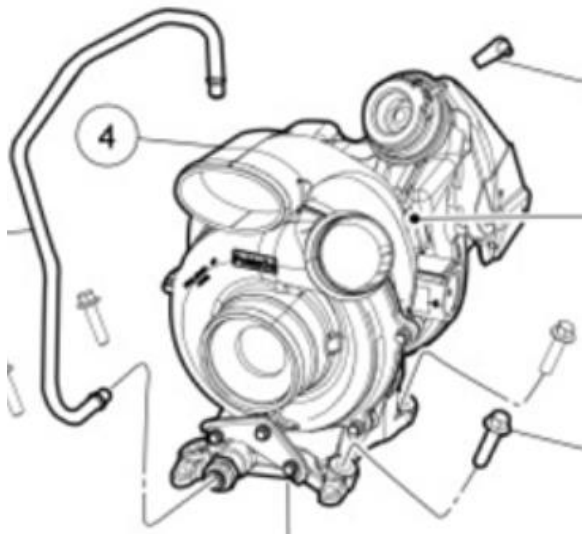

## Installation

When an engine or turbocharger is replaced due to a failure, inspect components for debris.

CAC and CAC tubes  
Exhaust manifolds  
EGR cooler and pipes  
Diesel Oxidation Catalyst

1. Clean all surfaces before proceeding.

Install the supplied new turbocharger mounting gasket. BC3Z-6587-A

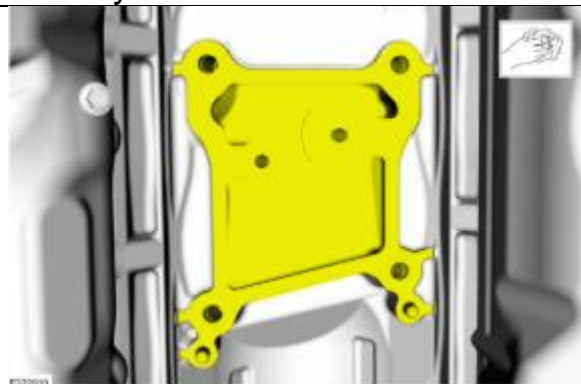

2. Install OEM 2011-2014 heat shield on BD supplied turbocharger. Use supplied M6 bolts FT-11115714.



3. Ensure turbocharger pedestal bolts are tight and torqued to 26ftlbs (35 Nm)

**Note:** The updated turbocharger uses an internally fed oil feed and does not require the external oil line.



4. Use gasket BC3Z-6587-A and insert turbocharger.

Ensure no debris is knocked into the engine through the pedestal mount.

Loosely install the mounting bolts.



BD Engine Brake Inc.

Plant Address: 33541 MacLure Rd. Abbotsford, BC, Canada V2S 7W2

U.S. Shipping Address: 1124 Fir Avenue, Blaine, WA 98230

U.S. Mailing Address: P.O. Box 231, Sumas, WA 98295

Phone: 604-853-6096 | Fax: 604-853-8749 | Internet: [www.bddiesel.com](http://www.bddiesel.com)

Notes: If using the BD manifolds, the passenger side heat shield may need to be hammered to fit or have a section removed near the turbine housing.



5. Connect hot-pipe feed tubes and lightly tighten v-band clamps.

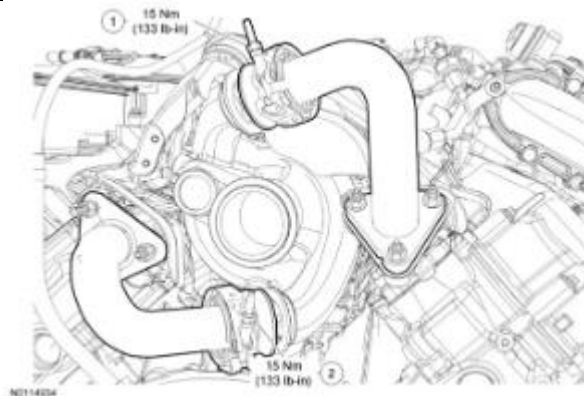

6. Tighten the 4 turbocharger mounting bolts.

Torque to 42 ftlbs (55 Nm)

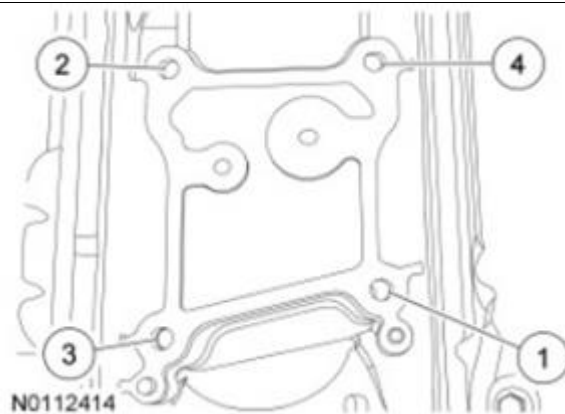

7. Tighten the hot-pipe feed tube v-band clamps.

Stage 1: 150 lb in (17 Nm)

Stage 2: Loosen 3 turns

Stage 3: 159 lb in (18 Nm)

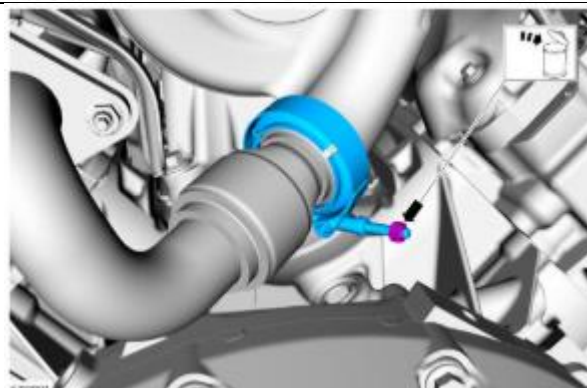

8. Connect turbocharger downpipe v-band clamp, and downpipe bracket bolt.

Tighten downpipe bracket bolt to 18 ft lbs (25 Nm).

Downpipe V-band Clamp to turbo: 159 lb in (18 Nm)

Upper to lower downpipe clamp: 41 lb ft (55 Nm)

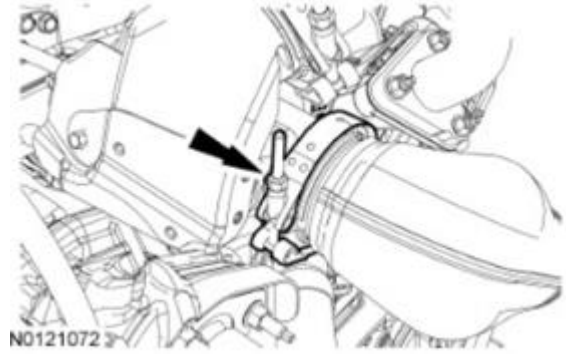

9. Re-install the lower exhaust downpipe bolts and torque to 26 lb ft (35 Nm).

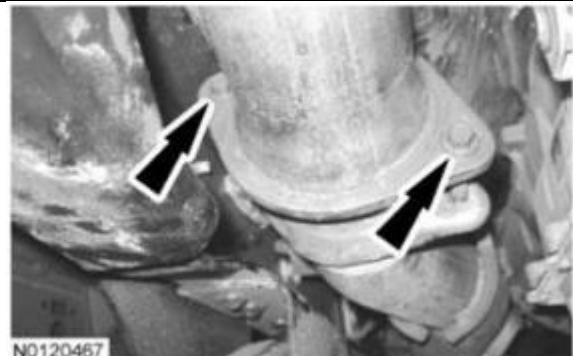

10. Ensure O-Ring 1407079 is installed on coolant spacer block 1405827.

Install the supplied coolant tube FC3Z-9U469-B using BD spacer block.

Use the supplied M6 x 65mm bolt FT-0135928.



11. Disconnect the turbocharger actuator electrical connector and disconnect the wastegate actuator vacuum hose on pickup models.

Cap the shown location where the wastegate actuator solenoid was fed using the supplied Rubber bullet cap (1900068). You should



now be able to remove the electrical solenoid if needed.

Note: Cab and Chassis models will not need to disconnect the wastegate actuator hose.

12. Pickup Trucks:  
plug in harness 1515950 into the wastegate solenoid harness and in-line with the exhaust back pressure sensor.

Cab & Chassis: move on to step 13.

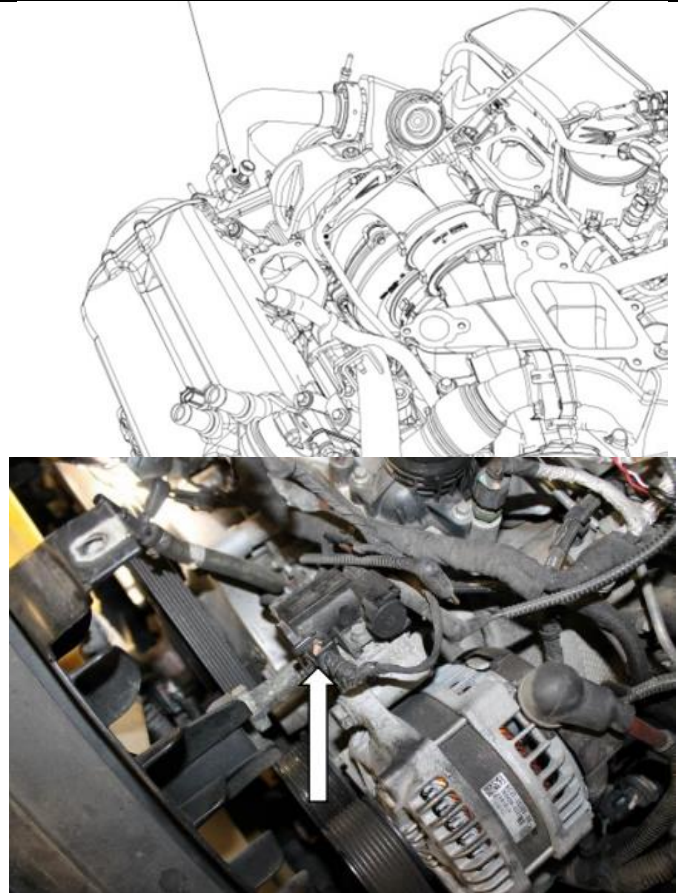



13. Pickup Trucks:  
Install BD boot cap 1405829 on the intake manifold. Install boot 1405858 onto the lower portion of the intake manifold. Use clamps FT-0427640 to secure both boots in place.

Cab & Chassis:  
Re-use the factory inlet boot and clamps.

Ensure clamp FT-0427642 is on the turbo inlet boot. Install lower intake manifold assembly.  
Torque to 18 lb ft (24 Nm).

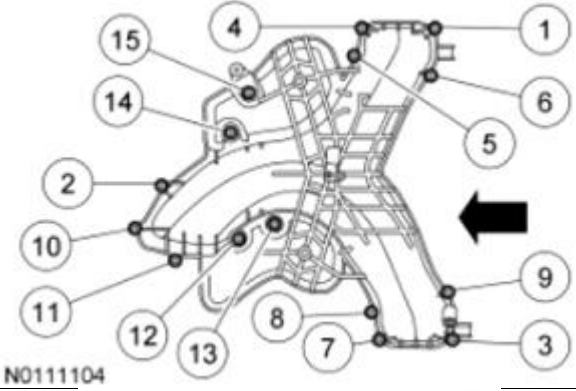
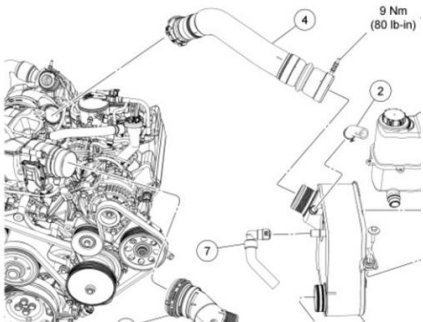

<p>14. Install the upper and lower intake manifold assembly. Torque to 89 in lbs (10 Nm).</p>	
<p>15. Reinstall the charge air cooler tube.</p>	
<p>16. Change the oil, oil filter, and refill the engine coolant. Perform an engine coolant pressure test to ensure there are no leaks.</p>	
<p>17. Reinstall the front right fender and tire.</p>	

# Troubleshooting

If your engine callibration has not been properly calibrated for the larger GT37 turbo, you may receive one of the below faults.

<p>P0299</p>	<p>Description: Turbocharger A Underboost Condition</p> <p>Solution: The Ford GT37 Retrofit kit requires a sufficient engine calibration. We recommend an Edge Evolution for 1045824 or PPEI for 1045825.</p>
<p>P1247</p>	<p>Description: Turbocharger Boost Pressure Low</p> <p>Solution: The Ford GT37 Retrofit kit requires a sufficient engine calibration. We recommend an Edge Evolution for 1045824 or PPEI for 1045825.</p>
<p>P1249</p>	<p>Description: Wastegate Control Valve Performance</p> <p>Solution: Install the provided 1515950 harness</p>
<p>P132B</p>	<p>Description: Turbocharger Boost Control A This DTC sets if the PCM detects that the difference between the manifold absolute pressure (MAP) readings are not greater than the calibrated value for a specified period of time when the intrusive monitor runs at idle (change from 1.0kpa to 2.0kpa)</p> <p>Solution: Monitor Vane Position, MAP and Exhaust Back Pressure (EBP) at idle. When the Vane Position is swept (intrusive monitor) EBP will vary, MAP must vary by 1.0-2.0kpa.</p>
<p>EBP Connector Won't "Click"</p>	