



P/N: F251-C & F252-C

INSTRUCTIONS PACKET

2010 - 2016 FORD F250 - F350
WITH 6.2L ENGINE
Max: 176 - Inch Maximum Wheelbase

F2-12



1. Remove the factory system by Unbolting the Joint in front the 2-1 resonator. Unbolting of hanger mount is required for factory removal.
2. Anti-seize surfaces of Ball with Flange, use the new bolts provided for re-installation. Leave Bottom Clamp in place for PC-22. Leave snug till step 5.
3. Install the muffler pack, ensuring the rear muffler measurement is correct to ensure proper tailpipe placement with offset toward the front.
4. Install the head pipe hanger and finally tighten all clamps to this point.
5. Install the RR tailpipe level, then clamp.
6. Install the RR hanger and then install tips, checking to ensure level and proper placement.
7. Use MPI-wire tie to secure brake lines and breather lines together.
8. Install the axle pipe and LR tail pipe, ensuring proper clearance for the spare tire and rear-end travel.
9. Install the LR hanger - Use bolt MPI - 3/8-1.5 to bolt through the chassis. Or unbolt T-30 Screw for hanger block
10. Install the LR tip, checking level and position to match RR.
11. Clean fingerprints off tips with glass cleaner, clean pipes with brake cleaner, and paint added hanger black on the chassis.

2010 - 2016 FORD F250 - F350
 Max: 176 - Inch Maximum
 Wheelbase

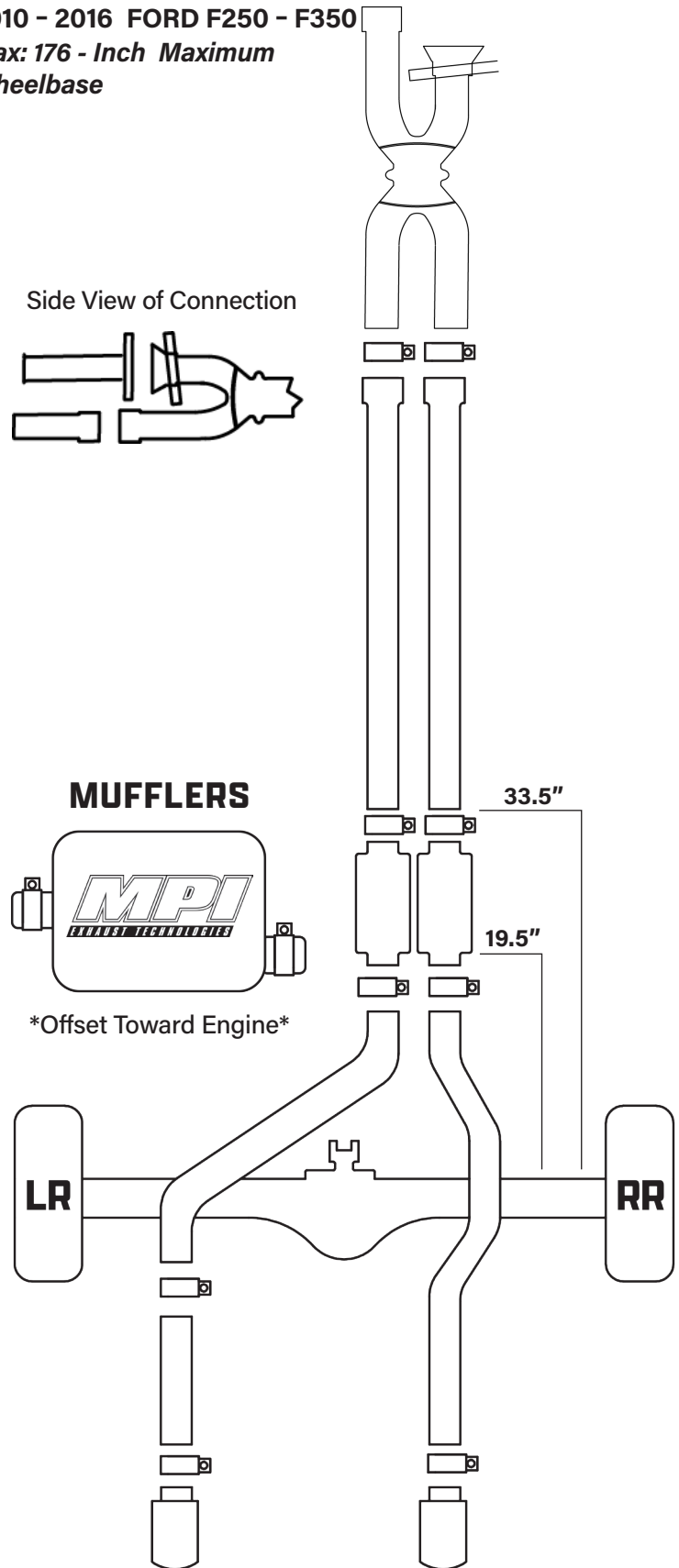

PARTS DIAGRAM

2010 - 2016 FORD F250 - F350
 Max: 176 - Inch Maximum
 Wheelbase

ITEM	QTY	PART NO.	DESCRIPTIONS
1.	1	MPI - 14	Right Side Tail Pipe
2.	1	MPI - 54	Left Side Tail Pipe
3.	1	MPI - 53	Left Side Axle Pipe
4.	2	MPI - 0 - 60	Head Pipes
5.	1	MPI - PC22	Pulse Chamber
6.	2	Hanger - 143	PC Hanger ★
7.	5	MPI - SC250	2 1/2" Clamp - Std.
8.	2	MPI - BCSS250	2 1/2" Band Clamp
9.	1	Hanger - 2	Head Pipe ▲
10.	1	Hanger - 3	Right Hand Muffler ●
11.	1	Hanger - 4	Left Hand Muffler ■
12.	1	Hanger - 1	Right Tail Pipe ◆
13.	1	Hanger - 5	Left Tail Pipe ⬠
14.	2	—	Mufflers
15.	2	2535	Tips
16.	2	MPI-Wire Tie	Wire Tie
17.	1	MPI - 3/8-1.5	Bolt - H02

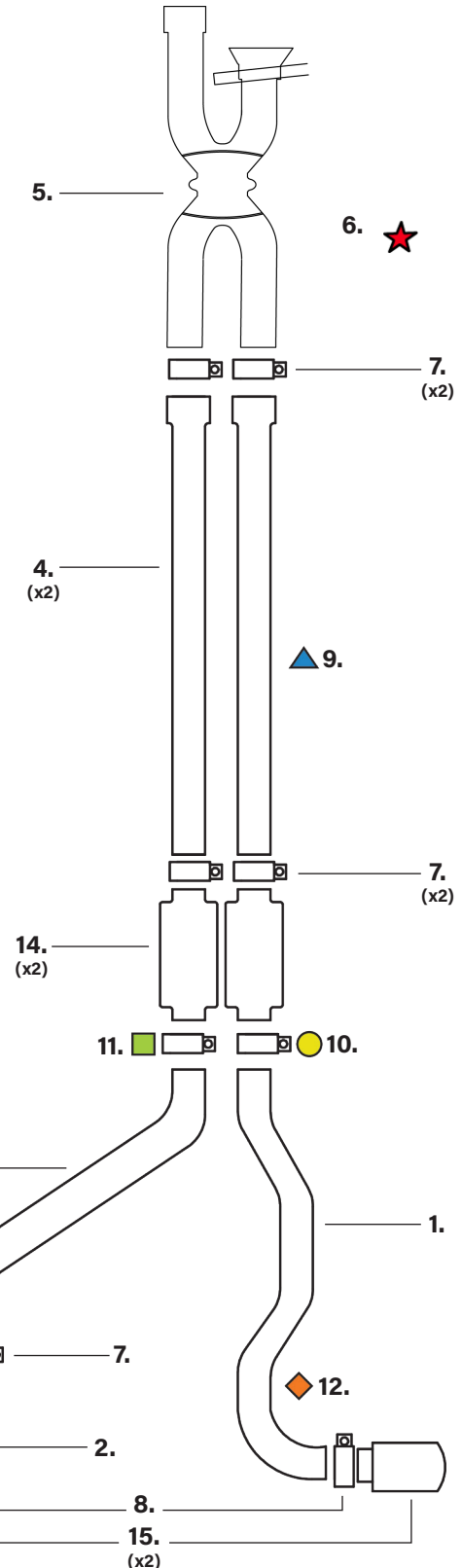

MUFFLER OFFSET DIAGRAM



PARTS DIAGRAM

2010 - 2016 FORD F250 - F350
 Max: 176 - Inch Maximum
 Wheelbase

ITEM	QTY	PART NO.	DESCRIPTIONS
1.	1	MPI - 15	Right Side Tail Pipe
2.	1	MPI - 55	Left Side Tail Pipe
3.	1	MPI - 53	Left Side Axle Pipe
4.	2	MPI - 0 - 60	Head Pipes
5.	1	MPI - PC22	Pulse Chamber
6.	1	Hanger - 143	PC - Hanger ★
7.	5	MPI - SC250	2 1/2" Clamp - Std.
8.	2	MPI - BCSS250	2 1/2" Band Clamp
9.	1	Hanger - 2	Head Pipe ▲
10.	1	Hanger - 3	Right Hand Muffler ●
11.	1	Hanger - 4	Left Hand Muffler ■
12.	1	Hanger - 1	Right Tail Pipe ◆
13.	1	Hanger - 5	Left Tail Pipe ⬡
14.	2	—	Mufflers
15.	2	2535	Tips
16.	2	MPI-Wire Tie	Wire Tie
17.	1	MPI - 3/8-1.5	Bolt - H02

MUFFLER OFFSET DIAGRAM

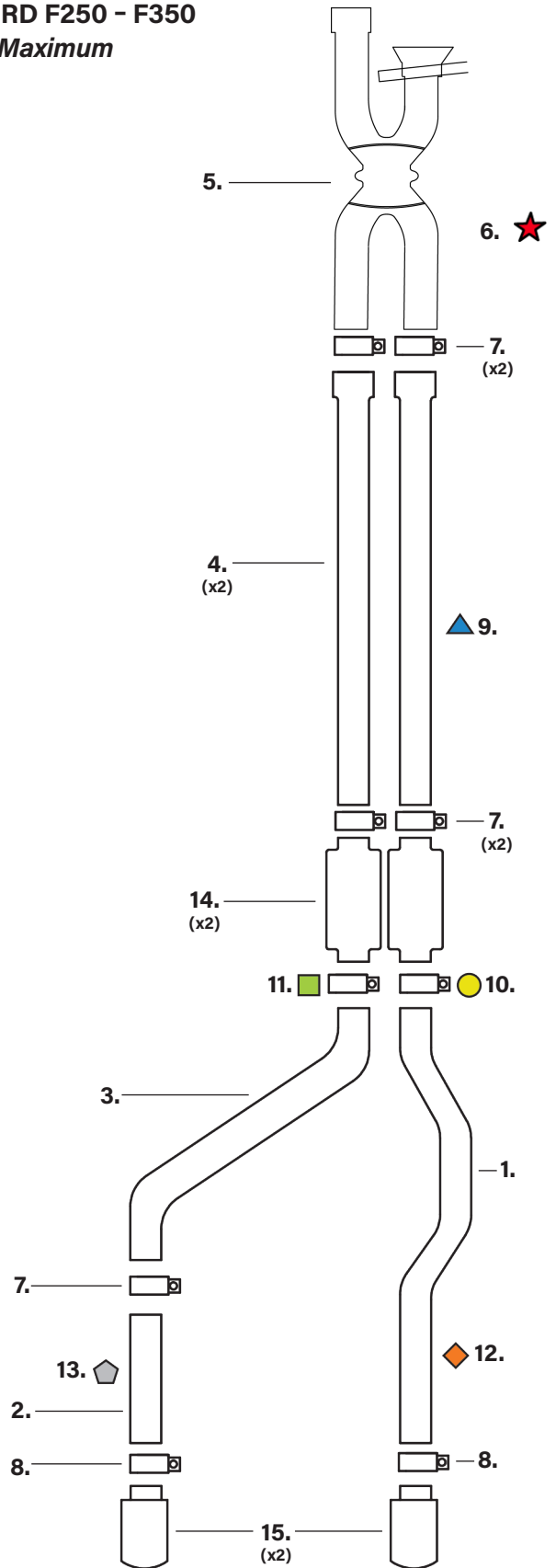



NEW MPI EXHAUST TIPS

BREAK-IN PROCEDURES

To ensure the MPI exhaust tips maintain their finish, follow these steps carefully to avoid any unwanted alterations:

- 1.** After installing the MPI system, clean all oils and fingerprints from the tips using a glass cleaner spray.
- 2.** Warm up the truck to full operating temperature, keeping the engine at idle without increasing RPMs. Then, allow the truck to fully cool down.
- 3.** Drive a short distance without exceeding half-throttle, varying speeds and throttle positions. DO NOT exceed ½ throttle during this time. Let the truck fully cool down before the next drive cycle.
- 4.** After this, you can drive normally but avoid full throttle for more than 10 seconds at a time.
- 5.** Avoid pulling trailers until the exhaust has been used for at least 500 miles.
- 6.** Regularly clean road salts and debris off the tips to preserve the finish.

QUESTIONS

Phone: (406) 669-3286

Email: mikespipesinc@gmail.com





WARRANTY



CUSTOMER SUPPORT AND WARRANTY INFORMATION

Thank you for choosing an MPI Exhaust Technologies System and allowing MPI Exhaust to customize your ride today! Our friendly and knowledgeable staff is here to answer any questions. Enjoy the Sound of Perfection.

QUESTIONS

ONLY contact MPI Exhaust Technologies if any products are potentially missing or damaged during shipping, or if you have any questions about the products. **Call (406) 669-3286.**



INSTALLATION

Watch the tutorial YouTube videos (scan the QR code) before installing or contacting MPI Exhaust. Our knowledgeable staff have installed hundreds of these kits.



WARRANTY

For more information scan the QR code.

CONTACT

Phone: (406) 669-3286

Email: mikespipesinc@gmail.com

