



# iBoard® Series

## INSTALLATION INSTRUCTIONS

**PART#: IB-003X C&H**

### BEFORE INSTALLATION

REMOVE CONTENTS FROM BOX. VERIFY ALL PARTS ARE PRESENT. READ INSTRUCTIONS CAREFULLY BEFORE STARTING INSTALLATION. ASSISTANCE IS RECOMMENDED. THANK YOU FOR CHOOSING OUR PRODUCT!

**\*ROCKER PANEL MOUNT**

**\*DRILLING IS REQUIRED**

### Torque Value

Fastener Size	Tightening Torque (ft-lbs)	Required
6mm	6-7	X
8mm	16-18	√
10mm	31-32	√
12mm	56-58	√
14mm	92-94	X



Scan for  
Installation Video

Mounting Bracket List			
Item	QTY	Bracket Label	Description
1#	6	DFM	Mounting Bracket for Driver / Passenger Front / Center
2#	1	DRM	Mounting Bracket for Driver Rear
3#	1	PRM	Mounting Bracket for Passenger Rear
4#	1	DRB	Bar Bracket for Driver Rear
5#	1	PRB	Bar Bracket for Passenger Rear
6#	2	DRS	Support Bracket for Driver Rear (1999-2010)
7#	1	DRS1	Support Bracket for Driver Rear 1 (2011-2016)

**PART LIST**

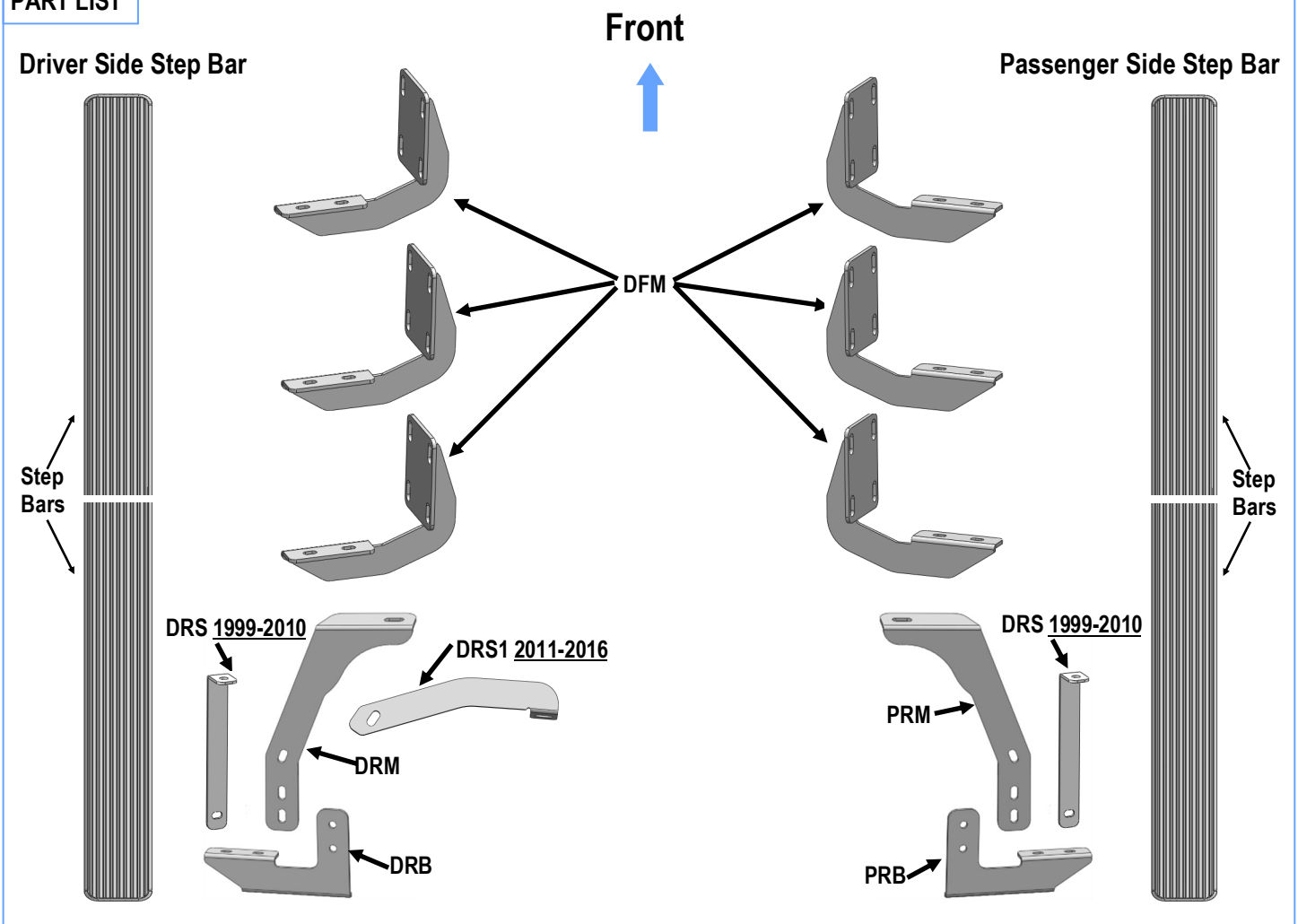

Customer Support: [info@iboardauto.com](mailto:info@iboardauto.com)



Scan for  
Installation Video

Hardware Package A (For Bracket Installation)					
Item	QTY	Description	Item	QTY	Description
A1	2	M12 Bolt/M10 Nut Plates	A7	30	M10X1.5-30mm Hex Bolts
A2	1	M12 Bolt Plates	A8	4	M10 Large Flat Washers
A3	2	M12X1.75-35mm Hex Bolts	A9	48	M10 Flat Washers
A4	4	M12 Flat Washers	A10	30	M10 Lock Washers
A5	3	M12 Lock Washers	A11	18	M10 Hex Nuts
A6	3	M12 Hex Nuts	A12	10	M10 Clip Nuts

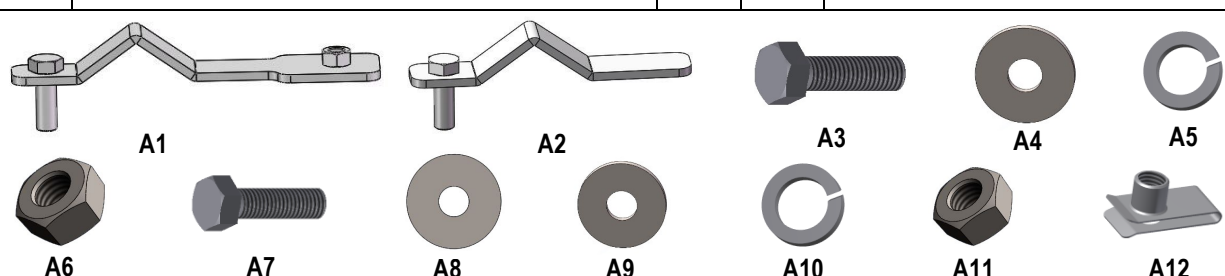

Hardware Package B (For Stainless Steel Step Bar Installation)					
Item	QTY	Description	Item	QTY	Description
B1	16	M8X1.25-35mm Carriage Bolts	B3	16	M8 Nylon Lock Nuts
B2	16	M8 Large Flat Washers	B4	8	Sliders (Packed with Step Bars)



Hardware Package C (For Stainless Steel Step Bar Assembly)					
Item	QTY	Description	Item	QTY	Description
C1	8	Plastic Rivets	C5	4	M8 Hex Nuts
C2	12	M8X1.25-25mm Inner Hex Bolts	C6	2	Plastic Covers (Packed with Step Bars)
C3	16	M8 Flat Washers	C7	2	Back Plates (Packed with Step Bars)
C4	12	M8 Lock Washers			

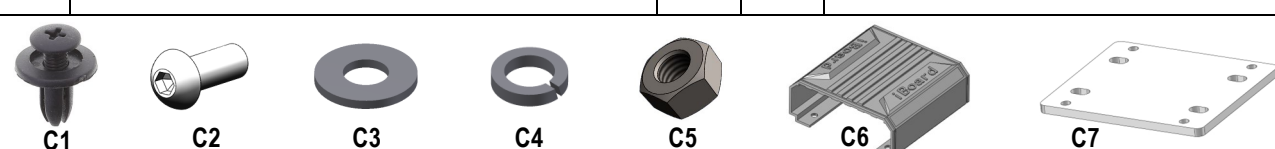



## STEP 1

### Step Bar Assembly:

- Assemble Step bars:** Select and assemble (2) Step Bars with (2) C2 (M8X1.25-25mm Inner Hex Bolts), (4) C3 (M8 Flat Washers), (2) C4 (M8 Lock Washers) and (2) C5 (M8 Hex Nuts), (Fig 1). **NOTE: (4) Step Bars are universal.**
- Back Plate Installation:** Attach (1) Back Plate to the bottom of the installed (2) Step Bars with (4) C2 (M8X1.25-25mm Inner Hex Bolts), (4) C3 (M8 Flat Washers), (4) C4 (M8 Lock Washers), (Fig 2).
- Plastic Cover Installation:** Secure (1) C6 (Plastic Cover) to the joint of (2) Step bars with (4) C1 (Plastic Rivets), (Fig 3).
- Repeat to assemble the other (2) Step Bars.

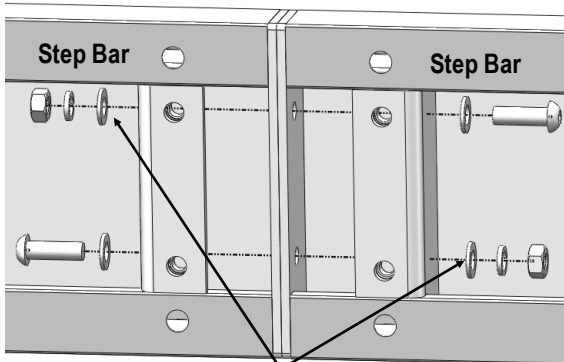

(2) C2 (M8X1.25-25mm Inner Hex Bolts)  
(4) C3 (M8 Flat Washers)  
(2) C4 (M8 Lock Washers)  
(2) C5 (M8 Hex Nuts)

(Fig 1) Step Bars Assembly

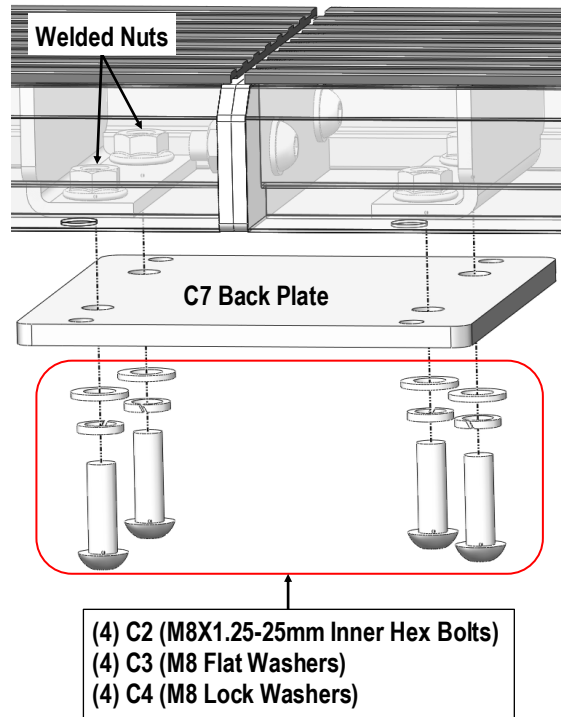

(Fig 2) Back Plate Installation

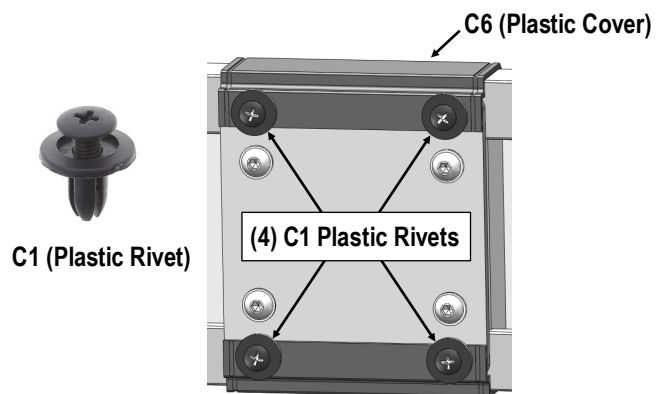

(Fig 3) Plastic Cover Installation  
(Bottom View)

### Assembled Step Bars





## STEP 2

Starting on the driver side front of the vehicle, locate the (4) pairs of factory holes in the pinch weld under the rocker panel, **(Fig 1)**. **NOTE:** Mounting locations may be covered with tape or undercoating. Remove tape and/or undercoating as necessary to ensure that Brackets are attached directly to the body panels.

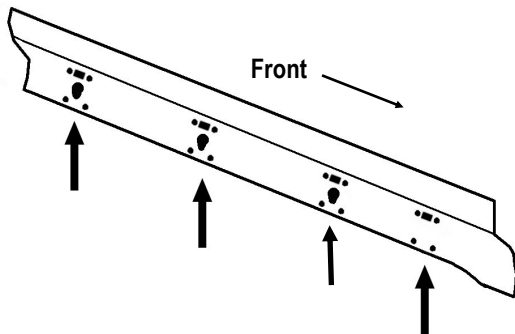

**(Fig 4) Driver Side Mounting Locations**

## STEP 3

Move to the driver side front mounting location, **(Fig 5)**. Locate (1) small round hole and (1) rectangular in the body panel and (2) holes in the pinch weld, **(Fig 5)**. Insert (1) A12 (M10 Clip Nut) into the rectangular opening and line up the threaded hole in the Clip with the round hole next to the opening. **NOTE:** Threaded nut must go towards the inside of the body panel.

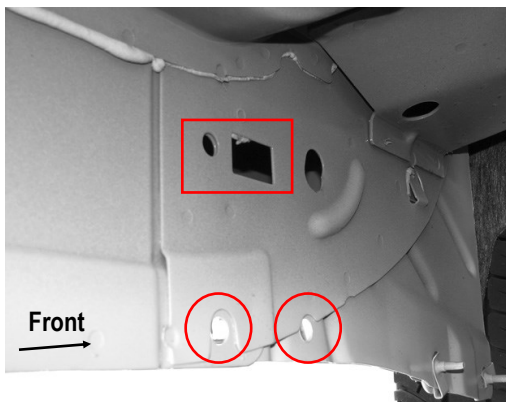

**(Fig 5) Driver Side Front Mounting Location**

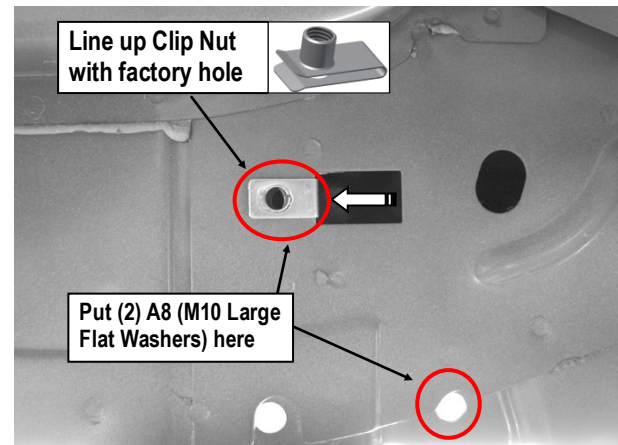

**(Fig 6) Insert (1) A12 (M10 Clip Nut)**

## STEP 4

Select (1) **DFM**. Insert (1) A7 (M10X1.5-30 Hex Bolt), (1) A10 (M10 Lock Washer) and (1) A9 (M10 Flat Washers) through the top hole of Mounting Bracket, (1) A8 (M10 Large Flat Washer) into the Clip Nut. Do not fully tighten hardware at this time.

Bolt the bottom of the Bracket to the pinch weld with the (2) A7 (M10X1.5-30 Hex Bolts), (2) A10 (M10 Lock Washers), (4) A9 (M10 Flat Washers) and (2) A11 (M10 Hex Nuts), **(Figs 7 & 8)**. **NOTE:** Insert Hex Bolts in from the outside, through the pinch weld and then the Bracket.

Put the other A8 (M10 Large Flat Washer) against the pinch weld, **(Figs 6 & 7)**.

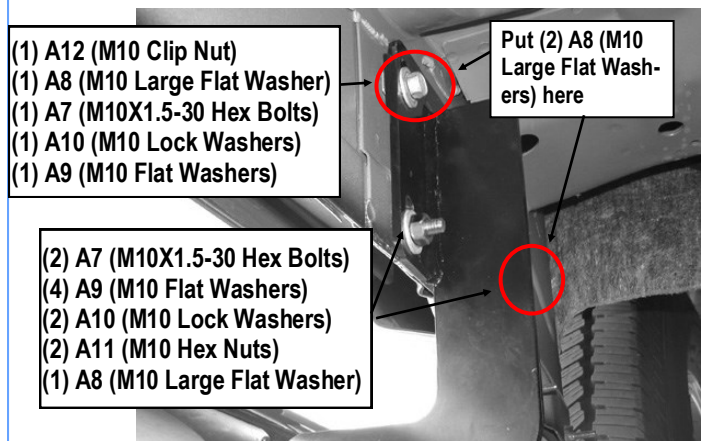

**(Fig 7) Driver Side Front Mounting Bracket Installed**

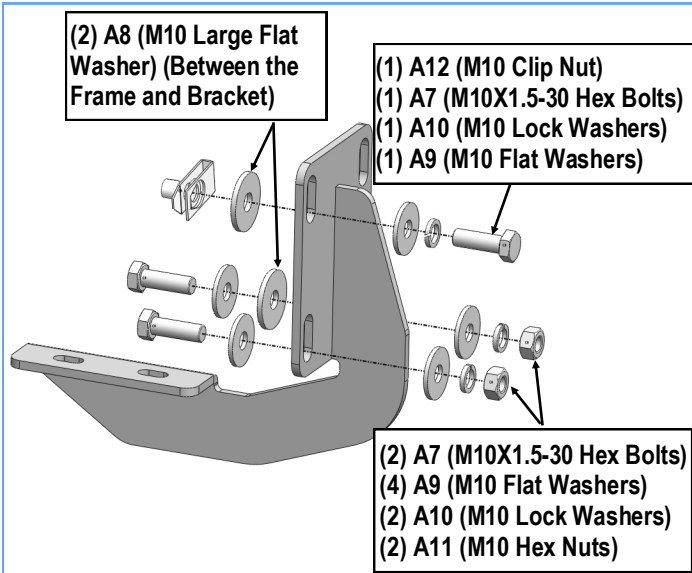

(Fig 8) Driver Side Front Mounting Bracket Installation

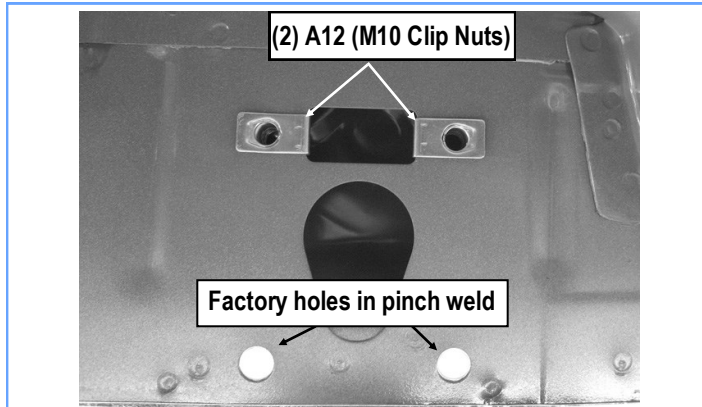

(Fig 10) Insert (2) M10 Clip Nuts

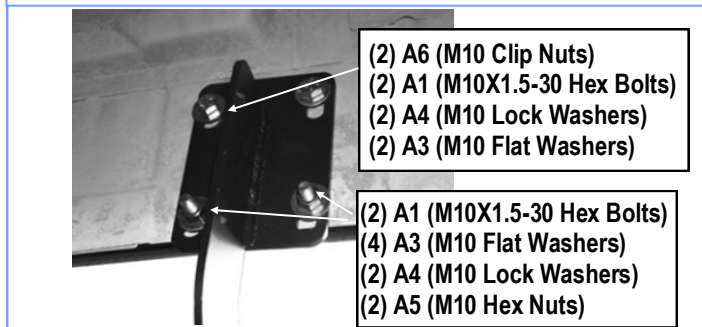

(Fig 11) Driver Center Mounting Bracket (DFM) Installed

## STEP 5

Move to the driver side center mounting location. Repeat **Step 3** to install (1) A12 (M10 Clip Nut), (**Figs 9-11**).

Attach (1) Mounting Bracket to the installed M10 Clip Nut with (1) A7 (M10X1.5-30 Hex Bolt), (1) A10 (M10 Lock Washer) and (1) A9 (M10 Flat Washer); to the pinch weld with (1) A7 (M10X1.5-30 Hex Bolt), (1) A10 (M10 Lock Washer), (2) A9 (M10 Flat Washers) and (1) A11 (M10 Hex Nut). Do not fully tighten hardware at this time. Repeat this step for the other center mounting Brackets.

**Note:** Front Mounting Bracket and Center Mounting Brackets are universal.

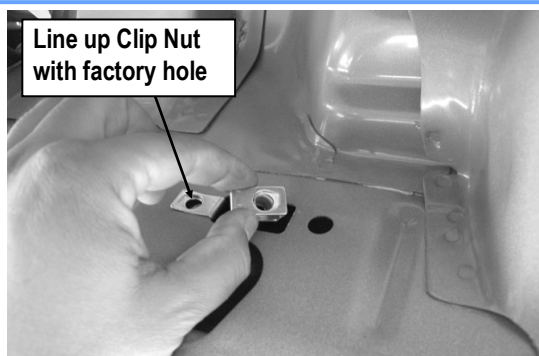

(Fig 9) Driver Side Center Mounting Location (Example)

## STEP 6

Assemble (1) Driver Rear Mounting Bracket (**DRM**) and (1) Driver Rear Bar Bracket (**DRB**) with (2) A7 (M10X1.5-30mm Hex Bolts), (2) A10 (M10 Lock Washers), (4) A9 (M10 Flat Washers) and (2) A11 (M10 Hex Nuts), (**Fig 12**). Do not fully tighten hardware at this time.

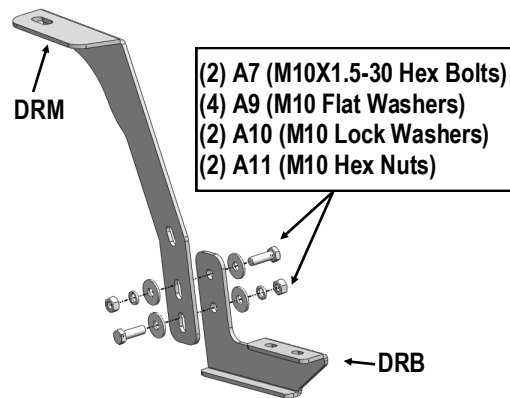

(Fig 12) Driver Rear Brackets Assembly



## STEP 7

Select the correct procedure for installing the assembled Driver Rear Bracket under the bed:

### 1999-2010 Driver side Rear Bracket assembly:

- Locate the square reinforcing tube welded to the bottom of the bed above and in front of the rear tire. Select (1) A1 (M12 Bolt/M10 Nut Plate). Hold the Bolt/Nut Plate upside-down against the bottom of the tube with the M12 Bolt inserted into the oval hole, (**Fig 13**). Mark the location of the Nut onto the bottom of the tube. Drill the location with a 7/16" Drill Bit.
- Insert the Bolt/Nut Plate into the tube with the M12 Bolt out through the factory hole, (**Fig 14**). Line up the M10 Nut with the drilled hole in the tube.
- Select the assembled Driver Rear Bracket, (**Fig 12**). Attach the Bracket to the M12 Bolt on the Bolt/Nut Plate with (1) A4 (M12 Flat Washer), (1) A5 (M12 Lock Washer) and (1) A6 (M12 Hex Nut), (**Fig 14**). Do not fully tighten hardware at this time.
- Select the Driver Rear Support Bracket (**DRS**) 1999-2010. Bolt the Bracket to the bottom of the tube and the M10 Nut on the Bolt/Nut Plate with (1) A7 (M10X1.5-30 Hex Bolt), (1) A10 (M10 Lock Washer) and (1) A9 (M10 Flat Washer), (**Figs 14 & 15**). Attach the lower end of the Support Bracket to the front side of the Mounting Bracket with (1) A7 (M10X1.5-30 Hex Bolt), (2) A9 (M10 Flat Washers), (1) A10 (M10 Lock Washer) and (1) A11 (M10 Hex Nut), (**Fig 14**). Do not fully tighten hardware at this time.

### 1999-2016 Passenger side Rear Bracket assembly:

Repeat the previous 1999-2010 driver side procedure (**Steps 7a—d**) for 1999-2016 passenger side rear bed bracket installation. Once completed, skip to **Step 8**.

### 2011-2016 Driver side only rear Bracket assembly:

- Release the plastic vent tube from the factory bracket, (**Fig 16**). Remove the plastic bracket from the square tube welded to the bottom of the bed. Insert the M12 Bolt Plate into the end of the tube and out the factory hole in the bottom, (**Fig 17**). Reinstall the plastic bracket and vent tube, (**Fig 18**).
- Select the assembled Driver Rear Bracket, (**Fig 12**). Attach the Bracket to the M12 Bolt on the Bolt Plate with (1) A4 (M12 Flat Washer), (1) A5 (M12 Lock Washer) and (1)

A6 (M12 Hex Nut), (**Figs 19**). Do not fully tighten hardware at this time.

- Select the Driver Rear Support Bracket 1 (**DRS1**) 2011-2016. Attach the 90-deg bent end of the Support Bracket to the hole in the top of the leaf spring bracket with (1) A3 (M12X1.75-35 Hex Bolt), (2) A4 (M12 Flat Washers), (1) A5 (M12 Lock Washer) and (1) A6 (M12 Hex Nut), (**Fig 19& 20**). Bolt the flat end of the Bracket to the Driver Rear Mounting Bracket with (1) A7 (M10X1.5-30 Hex Bolt), (2) A9 (M10 Flat Washers), (1) A10 (M10 Lock Washer) and (1) A11 (M10 Hex Nut), (**Fig 19**). Do not fully tighten hardware at this time.

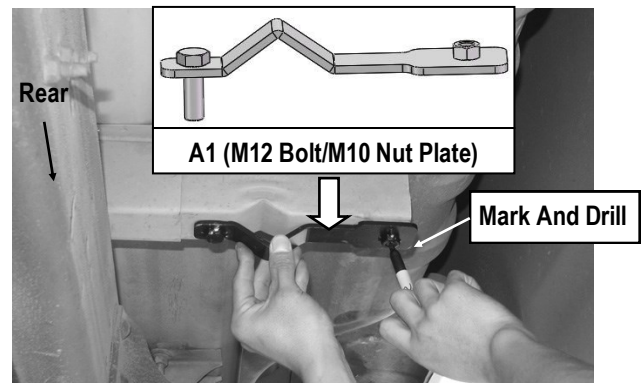

(Fig 13) Driver Side Rear Bracket Mounting Location ( 1999-2010 )

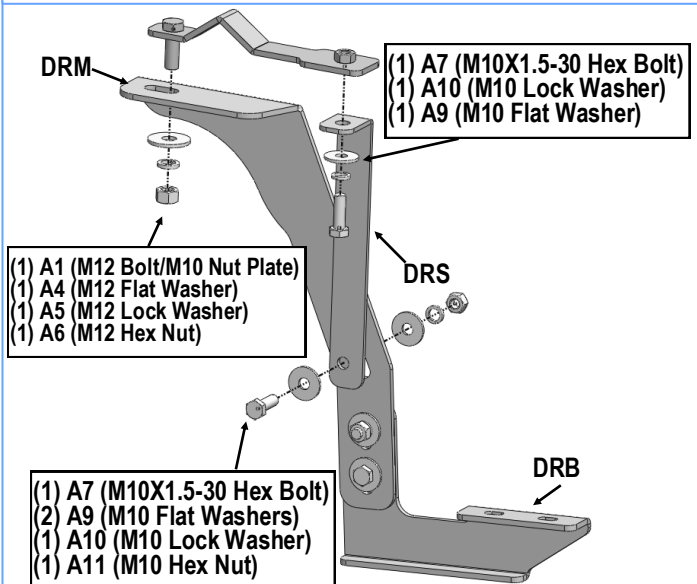

(Fig 14) Driver Side Rear Bracket Installation ( 1999-2010 )

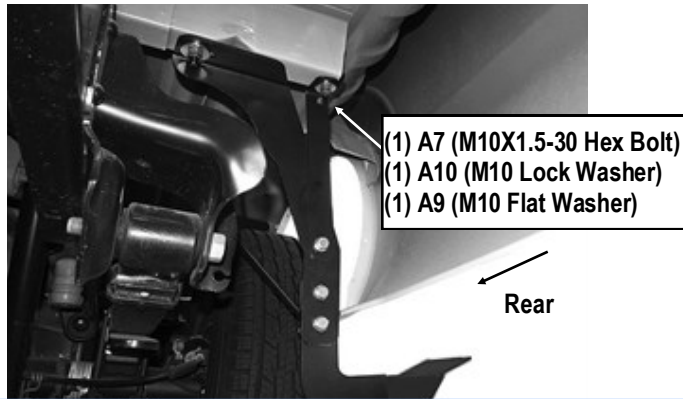

(Fig 15) Driver Side Rear Bracket Completely Installed (1999-2010)

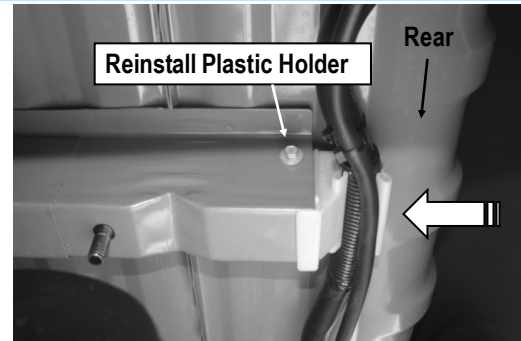

(Fig 18) Driver Side Rear Bracket Mounting Location (2011-2016)

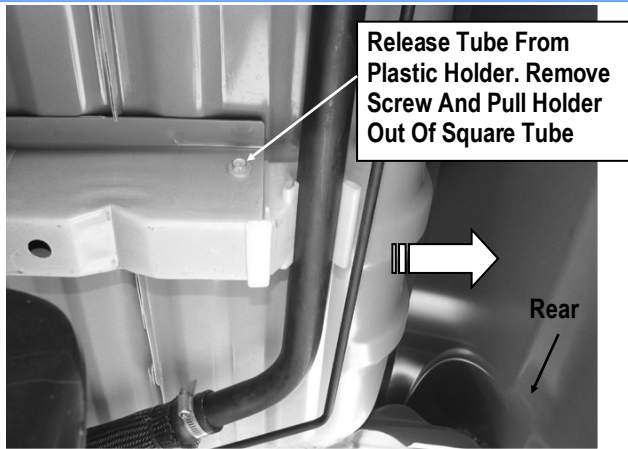

(Fig 16) Driver Side Rear Bracket Mounting Location (2011-2016)

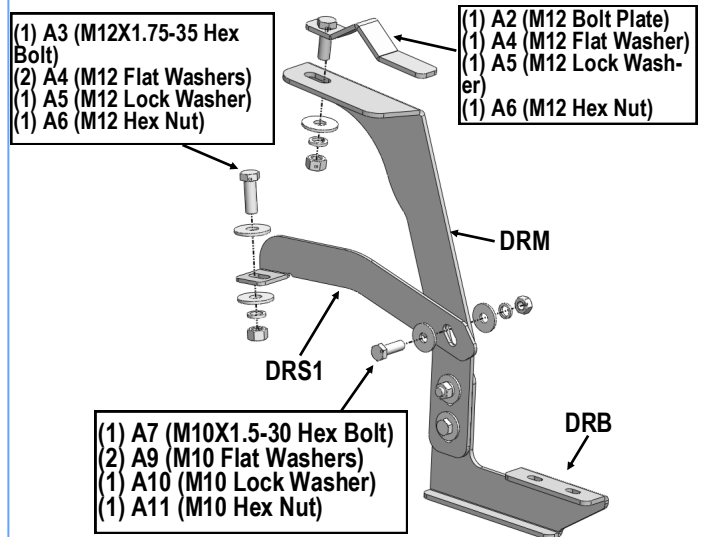

(Fig 19) Driver Side Rear Bracket Installation (2011-2016)

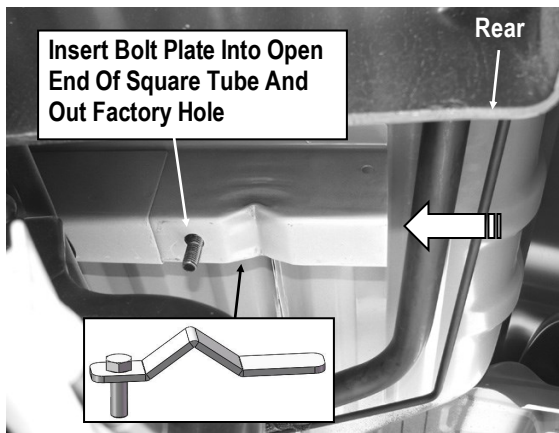

(Fig 17) Driver Side Rear Bracket Mounting Location (2011-2016)

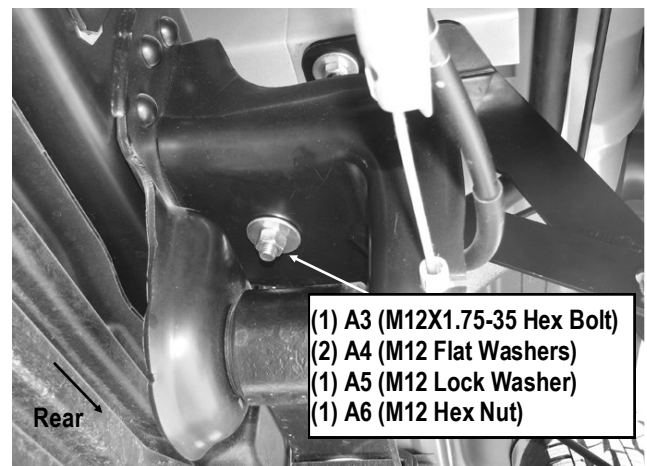

(Fig 20) Driver Side Rear Bracket Completely Installed (2011-2016)



## STEP 8

Once all (4) Driver side mounting brackets are installed, then proceed to the Step Bar installation. (Figs 21 & 22)

- (1) Select (1) B4 (Slider) and (2) B1 (M8X1.25-35 Carriage Bolts);
- (2) Install (2) B1 (M8X1.25-35mm Carriage Bolts) in (1) B4 (Slider).
- (3) Slide the Slider (with carriage bolts) to the **Step Bar**.
- (4) Repeat to install the other (3) B4 (sliders) to the step bar.
- (5) Attach the Step Bar (with the Sliders) onto the installed mounting brackets. Position the Sliders to the installed brackets. Secure the Step Bar to the installed Brackets by using (8) B2 (M8 Large Flat Washers) and (8) B3 (M8 Nylon Lock Nuts) and (4) B4 (Sliders), (Fig 22). Do not fully tighten hardware at this time.

**Note:** The Sliders are packed with the Step Bars.

Level and adjust the Step Bar and fully tighten all hardware.

Repeat **Steps 1-8** for the other side Step Bar installation. **The installation is completed!!!**

### Attention

Do periodic inspections to the installation to make sure that all hardware is secure and tight.

In order to protect your bars/boards, please use mild soap/non-abrasive products for cleaning only.

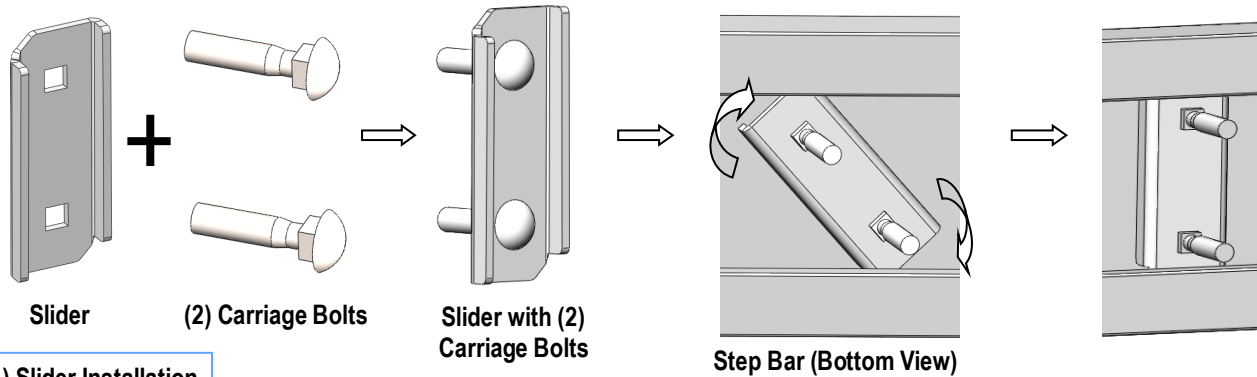

(Fig 21) Slider Installation

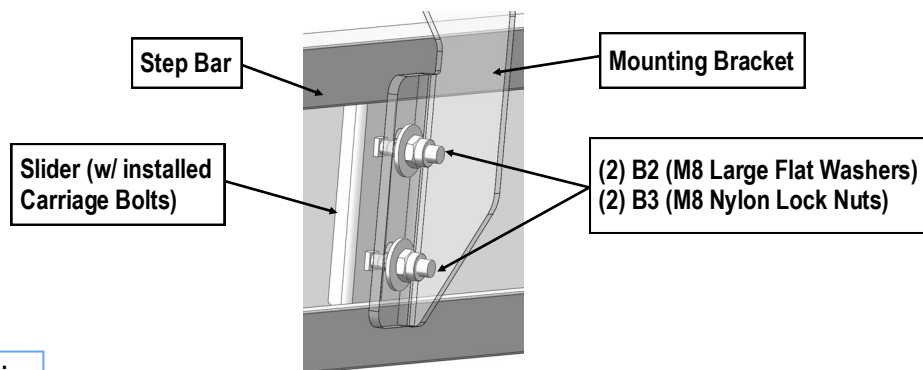

(Fig 22) Step Bar Installation