



ROUSH[®]
P E R F O R M A N C E

PREMIUM FUEL REQUIRED – NOT E85 COMPATIBLE

2011- 2014 Ford F-150 5.0L Phase 2 ROUSHcharger Kit

NOTE: 2014 REQUIRES ADDITIONAL SUPPLEMENTAL FEAD KIT 421821

P/N: 421435 (1150-P2CAL)

Installation Instructions

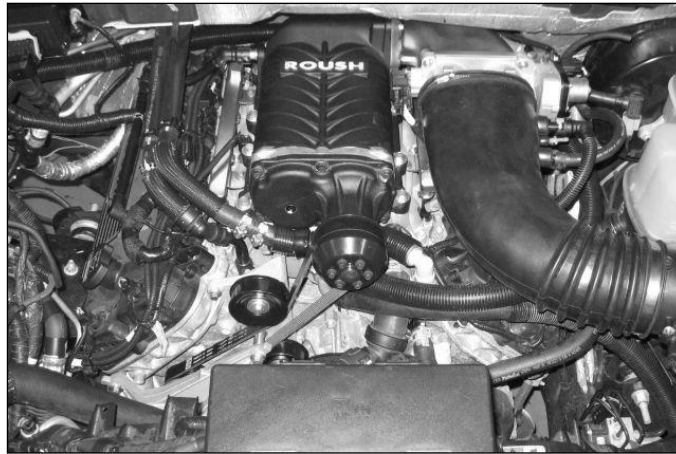

Application:

2011 - 2014 Ford F-150 with 5.0L 4-Valve Engine w/ Automatic Transmission
2014 Model Year Requires Additional Supplemental FEAD kit

Important Notes:

- Before installing your F-150 ROUSHcharger Kit, please read the installation manual and verify that all items are present. If you are missing hardware or have any questions, please contact ROUSH Performance at 1-800- 59-ROUSH.
- Premium fuel (91 octane or higher) is required to prevent “spark-knock” or detonation under certain operating conditions.**
- Once this modification has been completed this vehicle is no longer capable of running E85 (It is no longer a flex-fuel vehicle).**
- Operating your engine without the Roush PCM recalibration will result in engine damage or failure and will void your warranty.
- The use of fuel additives (ie. octane boosters) is not recommended. There is a possibility that these chemicals can damage your engine and cause drivability issues with your vehicle.
- Installation of this kit voids the 3 yr / 36,000 mile limited ROUSH Powertrain Warranty.**



ROUSH[®]
P E R F O R M A N C E

PREMIUM FUEL REQUIRED – NOT E85 COMPATIBLE

TABLE OF CONTENTS

PACKING LIST FOR ITEM 421435	3
EQUIPMENT AND SUPPLIES REQUIRED	7
GLOSSARY OF TERMS	8
INFORMATION ABOUT THE SUPERCHARGER BYPASS OPERATION	8
LIMIT OF LIABILITY STATEMENT	9
SAFETY PRECAUTIONS	9
SECTION A – DISASSEMBLY	10
SECTION B – MODIFICATIONS	20
Airbox Modification	20
Brake Booster Hose Modification.....	21
VMV Hose Modification	25
Heater Hose Modification	27
Front Cover Modification	29
Cowl Modification	32
TPS/ETC Wiring.....	34
Canister Purge Valve Wiring.....	36
Intercooler Pump Wiring	38
Air Charge Temperature (ACT) Wiring	40
Knock Sensor Orientation Adjustment	42
SECTION C – SUBASSEMBLY	44
Intercooler Low Temperature Radiator (LTR)	44
Intake Manifold Build Up.....	46
Throttle Body Spacer Assembly	47
Fuel Rail Assembly.....	49
SECTION D – INSTALLATION	50
Intercooler Reservoir Mounting.....	50
Intercooler Radiator Assembly Mounting.....	55
Intercooler Hose Circuit.....	60
Intake Manifold and Supercharger Installation.....	65
FEAD Assembly	73
Coolant Hoses	79
Air Induction System	82
Final Assembly	86
PCM Flashing	88



ROUSH[®]
P E R F O R M A N C E

PREMIUM FUEL REQUIRED – NOT E85 COMPATIBLE

PACKAGING LIST FOR ITEM 421435
(1150-P2CAL) SUPERCHARGER KIT

Part Ref	Description	Part Number	Qty
	Air Induction	---	
1	Upper Airbox Lid Assembly	1111-9A600	1
2	MAF Tube	11SC-12B579	1
3	MAF Tube to Airbox Lid Seal	1111-9645	1
4	Air Filter	997- 466	1
5	Clean Air Tube	11SC-9B659	1

Part Ref	Description	Part Number	Qty
	Hardware Kit A – Induction	11SC-TVSHKA	1
6	Bolt - M8 x 1.25 x 25	W500224	2
7	J-Clip M8	W520823	2
8	Vacuum Fitting – Brake Booster Reference	P2233A	1
9	Vacuum Fitting – S/C Bypass Reference	P217N	1

Part Ref	Description	Part Number	Qty
10	Fuel Charging Assembly	13119H487	1
11	Supercharger Assembly	1311H-6F066	1
12	Fuel Rail	13119F792	1
13	Throttle Body Assembly – Dual 60 mm	R07060150	1
14	Throttle Body Spacer Assembly	1150-9A589	1
15	Fuel Injector Clip	13119C995	8
16	Fuel Injector Kit	M-9593-LU47ROU	1
17	Spark Plug	CYSF 12YP	8

Part Ref	Description	Part Number	Qty
	Hardware Kit B – Fuel Charging	1150-TVSHKB	1
18	Gasket – Throttle Body To Spacer	R07060153	1
19	Gasket – Throttle Body Spacer to Supercharger	R07060152	1
20	Bolt – Throttle Body to Spacer & Supercharger (M6 x 32.5)	R18020009	8
21	Bolt – Intake to Cylinder Heads (M6 x 40)	R18020004	6
22	Bolt – Supercharger to Intake (M8 x 53)	N808130	10
23	Bolt – Supercharger Pulley (M6 X 14)	N605771	6

Part Ref	Description	Part Number	Qty
	FEAD	---	
24	Upper FEAD Bracket	13148B653U	1
25	FEAD Tensioner Bracket Assembly	13118B603	1
26	Supercharger Pulley – 6K 80mm	1313-6K80	1
27	Serpentine FEAD Belt	6K2085-8620	1



ROUSH[®]
P E R F O R M A N C E

PREMIUM FUEL REQUIRED – NOT E85 COMPATIBLE

Part Ref	Description	Part Number	Qty
	Hardware Kit C – FEAD	13116066FRTHKC	1
28	Pulley - Idler B/S 76mm	953045	2
29	Bolt – Idler (M8 x 28 large washer)	R18020060	2
30	Bolt – Upper FEAD to Engine and Intake (M8 x 84)	W704752	2
31	Bolt – Lower Bracket to Upper Bracket (M8 x 41)	W705128	1
32	Bolt - Upper FEAD to Engine (M8x60)	11127083	3
33	Bolt – Lower Bracket to Engine (M8 x 120)	N811329	2

Part Ref	Description	Part Number	Qty
	PCV & Vacuum	---	
34	PCV Fresh Air Inlet	AR3Z-6758	1
35	PCV Purge Hose with Bubbler	13116K817	1
36	Evaporative Emission Canister Purge Valve Line	27004	1
37	Clamp – Worm Drive (VMV Line & Brake Booster)	62003	4
38	7/32" Vacuum Hose – Supercharger Bypass (4")	R18140001	1
39	7/32" Vacuum Harness – Supercharger Bypass Reference (23")	R18140001	1
40	½" x 3/8" Adapter Fitting – Brake Booster Hose	5463K225	1
41	Split Loom Convolute – ¾"	1312-TRANSCONV	1

Part Ref	Description	Part Number	Qty
	Wiring	---	
42	Electrical Jumper – Intercooler Pump	13118W501	1
43	ACT Wiring Harness	131112A690	1
44	TPS Extension Harness	131114A595	1
45	Canister Purge Valve (VMV) Extension Harness	13119G866	1

Part Ref	Description	Part Number	Qty
	Decals / Labels & Instructions	---	
46	Decal – 2011 Belt Routing Diagram	13116E072	1
47	Decal – Premium Fuel Only – No E85	R07110005	1
48	Decal – Premium Unleaded Fuel Only	13109A095	1
49	Decal – EO Label (D-418-**)	D418**-9A095EO	1
50	Warranty Registration Card	1150-TVSCALWC	1
51	Limited Base Warranty Information	1150-LBW	1
52	Go to Website - Installation Manual One Pager	1315-P1INST	1



ROUSH[®]
P E R F O R M A N C E

PREMIUM FUEL REQUIRED – NOT E85 COMPATIBLE

Part Ref	Description	Part Number	Qty
	Intercooler System	---	
53	Degas Bottle	R07070007	1
54	Intercooler Electric Water Pump with Bracket	392022009	1
55	Bracket - LTR Upper Cross Brace	1111-8K241	1
56	Intercooler Low Temp Radiator (LTR)	1111-8K229	1
57	3/4" Hose – Degas Bottle Inlet	1111-8D031	1
58	3/4" Hose – Intercooler Pump Inlet	1111-8D029	1
59	3/4" Hose – Intercooler Pump to LTR	1111-8K236	1
60	3/4" Hose – Intercooler LTR Outlet	1111-8D030	1
61	Hose Assembly – Heater Inlet	1150-18K579	1

Part Ref	Description	Part Number	Qty
	Hardware Kit D – Intercooler System	11SC-TVSHKD	1
62	Bracket – LTR Upper LH	1111-8K242	1
63	Bracket – LTR Upper RH	1111-8K243	1
64	Bracket – LTR Lower LH	1111-8K244	1
65	Bracket – LTR Lower RH	1111-8K245	1
66	Bracket - Intercooler Pump Mounting	1111-8C419	1
67	Clamps – 3/4" Hoses (Constant Tension)	CT19x12-BO	8
68	Bolt M8 x 1.25 x 30 - LTR Mounting Brackets	N808920	8
69	Nut – I/C Pump Mounting Bracket (M8)	W520413	2
70	Nut - M6 x 1.0 - I/C Relay Mntg	W520412	1
71	Bolt – M6 x 1.0 x 20 (I/C Relay Mntg)	W500214	1
72	Bolt – M8 x 1.25 x 27 (Self Tapping) I/C Cross Brace Mounting	N802455	2
73	NVH Isolator – I/C Pump to LTR	13108Y419	1

Part Ref	Description	Part Number	Qty
	Hardware Kit E – Degas Bottle Mounting	1150-TVSHKE	1
74	Degas Bottle Cap	9C3Z-8101-B	1
75	Nut – Degas Strut Mounting Bracket Upper to Lower (M8)	W520413	2
76	Bolt - M6 x 1.0 x 8 - Degas Bottle to Strut Bracket	R18020010	1
77	Nut - M6 x 1.0 - Degas Bottle to Fender Bracket	W520412	2
78	Mounting Bracket - Degas Bottle to Strut Mount Upper	1111-6B634U	1
79	Mounting Bracket - Degas Bottle to Strut Mount Lower	1150-6B634L	1
80	Mounting Bracket - Degas Bottle to Inner Fender	1111-6B633-AA	1



ROUSH[®]
P E R F O R M A N C E

PREMIUM FUEL REQUIRED – NOT E85 COMPATIBLE

Part Ref	Description	Part Number	Qty
	CALKIT	1150-P2CALKIT	1
81	Optional Roush PCM Flash	PCM-FLASHDOC	1
82	Flash Voucher Card	P1150-P2	1

If you are missing any items, please call us toll free at 1-800-59-ROUSH.



ROUSH[®]
P E R F O R M A N C E

PREMIUM FUEL REQUIRED – NOT E85 COMPATIBLE

EQUIPMENT AND SUPPLIES REQUIRED

- 1/4" and 3/8" Drive Ratchets with Extensions
- Metric and Standard Socket Sets (short and deep recommended)
- 1/2" Drive Ratchet or Breaker Bar
- Metric and Standard Wrench Sets
- 3/8" Drive Torque Wrench (7-35 ft-lb range)
- Short Phillips-head Screwdriver
- 5/8" Fuel Line Removal Tool
- T-20 Torx Bit Screwdriver or Socket
- 5/16" Drill Bits and Drill motor
- Coolant (meeting Factory Ford specification for 2011+ F-150)
- 6" Scale, Tape Measure, or Other Measuring Device
- Assembly Lubricant (White Lithium Grease or Petroleum Jelly)
- Electrical Tape
- Sharp Knife or Razor Blade
- Solder & Soldering Iron
- Heat Gun or Small Torch for Heat Shrink Tubing
- Tie Straps (Zip Ties)
- Trim Pad Tool (for pushpin removal)
- Hammer (Mini-Sledge)
- Fender Cover (2)
- Medium Strength Thread Locker - Loctite 242 (Blue) or equivalent



ROUSH[®]
P E R F O R M A N C E

PREMIUM FUEL REQUIRED – NOT E85 COMPATIBLE

GLOSSARY OF TERMS

ACT	Air Charge Temperature Sensor (From the factory, this function is integrated into the MAF sensor. With this kit, a separate ACT sensor is installed into the intake manifold)
ETC	Electronic Throttle Control
MAFS	Mass Air Flow Sensor
PCM	Powertrain Control Module (a.k.a. ECM, ECU, PCU, EEC)
PCV	Positive Crankcase Ventilation
TPS	Throttle Position Sensor
RDT	ROUSH Diagnostic Tool
VMV	Vapor Management Valve (aka Canister Purge Valve)
Breakout Point	A place in an electrical harness where the wiring for an individual component leaves (breaks out of) the main harness to attach to an individual component.

INFORMATION ABOUT THE SUPERCHARGER BYPASS OPERATION

There is a great deal of misinformation about the function of supercharger bypass systems. The supercharger is a positive-displacement pump; that is, so long as it is rotating, it is always pumping air. During low demand or high vacuum operation (i.e. idle, deceleration, and light throttle cruise), the pumping action is undesirable as it creates unwanted heat and noise. The bypass circuit, when open, prevents any pressure buildup across the supercharger and allows air to circulate through the rotors, allowing the supercharger to “idle” freely during these conditions. This results in reduced noise, and by reducing heat buildup in the intake, significantly improves street and strip performance. As throttle demand increases, the bypass circuit is closed, resulting in full performance from the supercharger. The bypass circuit is never used to limit or control boost during full-throttle operation and defeating or altering the bypass function will not result in improved performance in any condition, and will result in poor drivability.



ROUSH[®]
P E R F O R M A N C E

PREMIUM FUEL REQUIRED – NOT E85 COMPATIBLE

LIMIT OF LIABILITY STATEMENT

The information contained in this publication was accurate and in effect at the time the publication was approved for printing and is subject to change without notice or liability. ROUSH Performance Parts reserves the right to revise the information presented herein or to discontinue the production of parts described at any time.

SAFETY PRECAUTIONS

STOP! CAREFULLY READ THE IMPORTANT SAFETY PRECAUTIONS AND WARNINGS BEFORE PROCEEDING WITH THE INSTALLATION!

Appropriate disassembly, assembly methods and procedures are essential to ensure the personal safety of the individual performing the kit installation. Improper installation due to the failure to correctly follow these instructions could cause personal injury or death. Read each step of the installation manual carefully before starting the installation.

- ! Always wear safety glasses for eye protection.
- ! Place the ignition switch in the OFF position.
- ! Always apply the parking brake when working on the vehicle.
- ! Block the front and rear tire surfaces to prevent unexpected vehicle movement.
- ! Operate the engine only in well-ventilated areas to avoid exposure to carbon monoxide.
- ! Do not smoke or use flammable items near or around the fuel system.
- ! Use chemicals and cleaners only in well-ventilated areas.
- ! Batteries can produce explosive hydrogen gas which can cause personal injury. Do not allow flames, sparks or flammable sources to come near the battery.
- ! Keep hands and any other objects away from the radiator fan blades.
- ! Keep yourself and your clothing away from moving parts when the engine is running.
- ! Do not wear loose clothing or jewelry that can be caught in rotating or moving parts.



ROUSH[®]
P E R F O R M A N C E

PREMIUM FUEL REQUIRED – NOT E85 COMPATIBLE

SECTION A – DISASSEMBLY

The following section will guide you through the disassembly of the stock components. Special care should be taken to label fasteners and parts that are taken off during this procedure since many will be reused:

1. Cover both fenders with fender covers to protect the vehicle finish.
2. Release the fuel system pressure (**NOTE:** The following procedure is taken directly from the Ford Service Manual).



WARNING: Fuel in the fuel system remains under high pressure even when the engine is not running. Before working on or disconnecting any of the fuel lines or fuel system components, the fuel system pressure must be relieved. Failure to do so can result in personal injury.



WARNING: Do not smoke or carry lighted tobacco or open flame of any type when working on or near any fuel-related components. Highly flammable mixtures are always present and can be ignited, resulting in personal injury.

- a. Disconnect the Fuel Pump Control Module electrical connector. It is located on the frame rail above the spare tire.

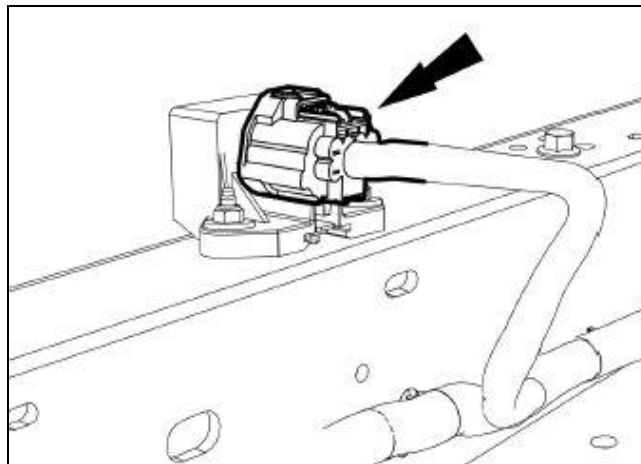

- b. Start the engine and allow it to idle until it stalls.
- c. After the engine stalls, crank the engine for approximately 5 seconds to make sure the fuel rail pressure has been released.
- d. Turn the ignition switch to the OFF position.



ROUSH[®]
P E R F O R M A N C E

PREMIUM FUEL REQUIRED – NOT E85 COMPATIBLE

3. Using an 8mm wrench, disconnect the (-) negative & (+) positive connections to the battery and remove the battery from the vehicle.



Before continuing, refer to the CALKIT included with your ROUSHcharger kit. Determine the PCM flash method you will be using. If performing the PCM flash yourself or at a preferred ROUSH dealer, proceed to step 6. If sending the PCM to ROUSH for a ROUSH performed PCM flash, continue with steps 4 and 5.

4. Remove the PCM cover by undoing the two crimp nuts retaining the cover to the studs.
5. Undo the three (3) PCM (Powertrain Control Module) connectors by lifting the grey levers over the connector back shell and lifting the connectors from their sockets. Remove the PCM by removing the two studs and pulling the PCM forward and lifting out of the engine compartment. Follow the instructions on the next page as soon as possible to help minimize the amount of time you are without a PCM.

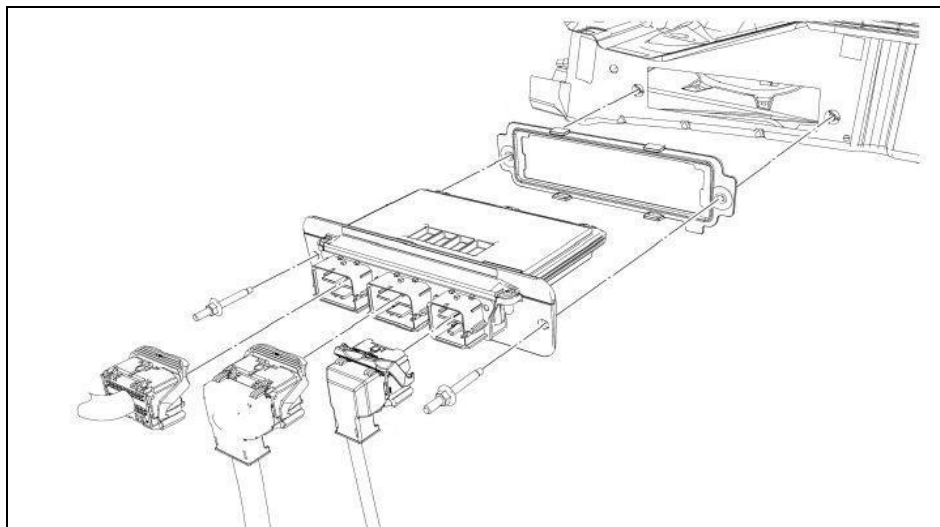

Important: Be sure to write your VIN number and phone number on the PCM using a permanent marker.

Please do this in the case that we need to contact you for additional vehicle information.



ROUSH[®]
P E R F O R M A N C E

PREMIUM FUEL REQUIRED – NOT E85 COMPATIBLE

INSTRUCTIONS FOR RETURNING THE PCM TO ROUSH FOR CALIBRATION

Outlined below are the instructions for returning your stock powertrain control module (PCM) to Roush Performance Products so we can install our calibration to make the engine run properly with the new components. **Please complete the “Base Limited Warranty Registration” card and include it, along with the PCM, the “Optional Roush PCM Flash” request document, and the “Voucher Card”.** Once we receive your PCM, we will reprogram and return it back to you the same day for next-day delivery. **Operating your engine without our calibration will result in engine damage or failure and will void all warranty.**

Note: It is important to reinstall the PCM in the vehicle it came from to prevent setting a trouble code and having to relearn the anti-theft code which can only be performed using specialized Ford Service Bay tools.

- If you haven't already done so, write your vehicle identification number (VIN) and phone number on the PCM using a permanent marker.
- Using bubble wrap, or another appropriate packing material, wrap and package the PCM to help prevent it from being damaged during shipping.
- Place the wrapped PCM in an appropriate shipping box.
- **Complete the “Warranty Registration Card” (1150-TVSCALWC),**
- **Complete the “Optional ROUSH PCM Flash” request document (PCM-FLASHDOC) and attach the flash Voucher Card (P1150-P2) to the document.**
- **Include the “Warranty Registration Card”, “Optional ROUSH PCM Flash” document, and the Voucher Card in the shipping box, along with the PCM.**
- Ship the PCM and contents to:

**ATTN: PCM FLASH
39555 Schoolcraft Rd
Plymouth, MI 48170**

Upon receipt of the PCM, a customer service representative will contact you to arrange payment. Once you receive your ROUSH flashed PCM, reverse steps 4 and 5 for PCM installation.



ROUSH[®]
P E R F O R M A N C E

PREMIUM FUEL REQUIRED – NOT E85 COMPATIBLE

6. With the engine cool, remove the cap on the engine coolant degas reservoir bottle and the upper radiator fill cap. Drain the coolant using the petcock located on the lower passenger side of the radiator. Re-tighten the petcock once the engine coolant has been drained.

TIP: Connect a 3/8" hose to the drain fitting next to the petcock and run into a clean drain pan or bottle. Use a 3/4" wrench to open petcock and allow coolant to drain out of the fitting.

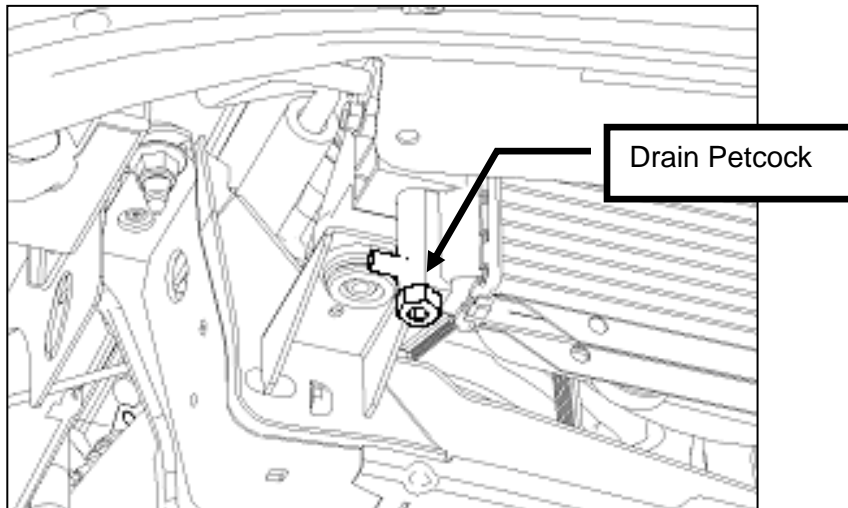

7. Disconnect the PCV Fresh Air Inlet tube from the left-hand (drivers side) cam cover and the clean air tube. Remove hose from vehicle. Disconnect the brake booster vacuum hose from the clean air tube. Disconnect the clean air tube from the throttle body and the upper airbox lid. Remove the clean air tube from the vehicle. Neither of these components will be reused.

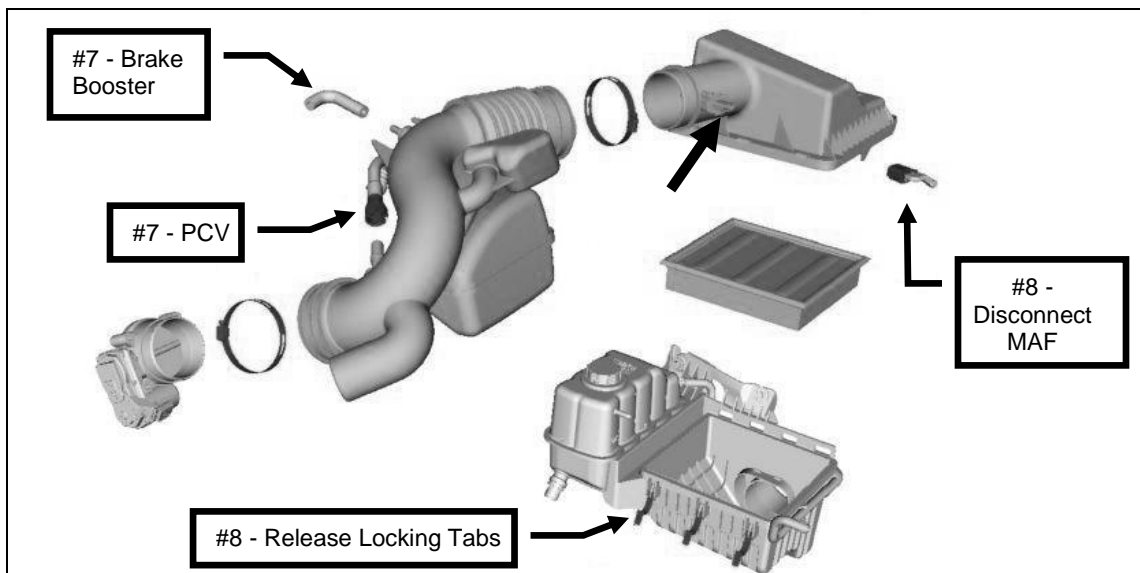



ROUSH[®]
P E R F O R M A N C E

PREMIUM FUEL REQUIRED – NOT E85 COMPATIBLE

8. Remove the MAF (Mass Air Flow) sensor electrical connector by pulling the red locking tab back and pressing the black release tab. Release the three locking tabs securing the upper airbox lid to the lower airbox. Remove the upper airbox lid and filter from the vehicle. The airbox lid and filter will not be reused.
9. Disconnect the heater return hose quick connect fitting on the front drivers side of the engine. Disconnect the quick connect fitting at the cowl, undo the clip holding the two heater hoses together and remove this hose from the vehicle. It will be modified at a later step.
10. Remove the PCV Purge line from the intake manifold and passenger side cam cover. This line will not be reused.
11. Disconnect the heater supply hose quick connect fitting on the front passenger side of the engine. Position this hose aside.

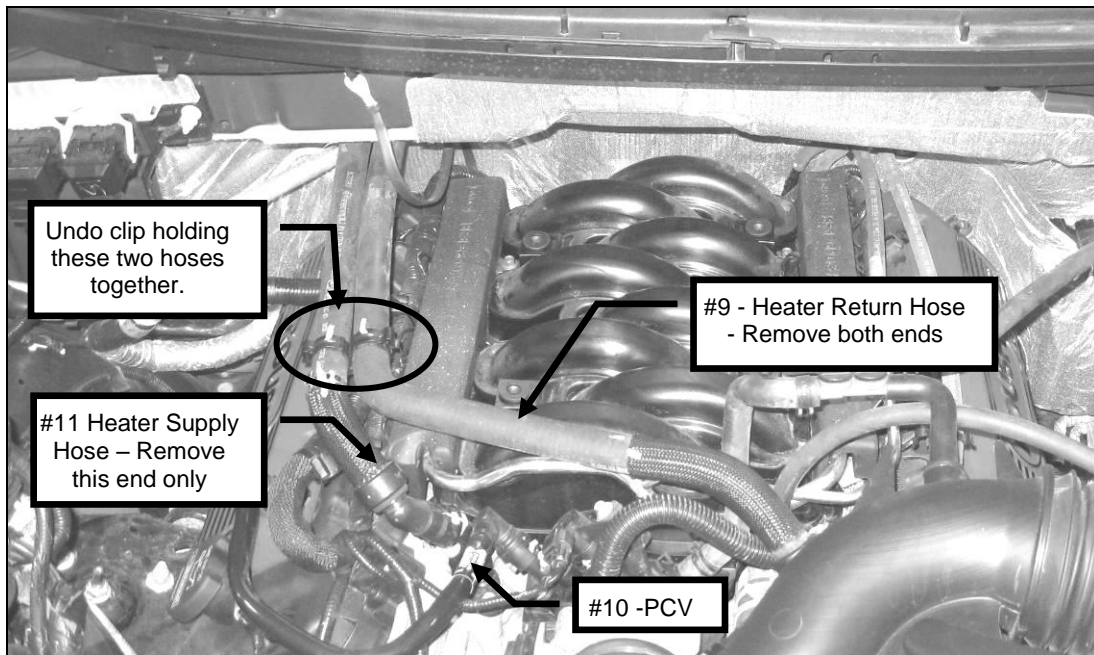

12. Disconnect the throttle body electrical connector. (Pull the red locking tab back; press the black release tab to disengage the lock). Refer to #12 in figure shown below.
13. Disconnect the VMV (evaporative emission canister purge valve) tube and electrical connector. Remove the VMV tube retainer from the fuel rail and fuel supply line. Refer to #13 in figure shown below.



ROUSH[®]
P E R F O R M A N C E

PREMIUM FUEL REQUIRED – NOT E85 COMPATIBLE

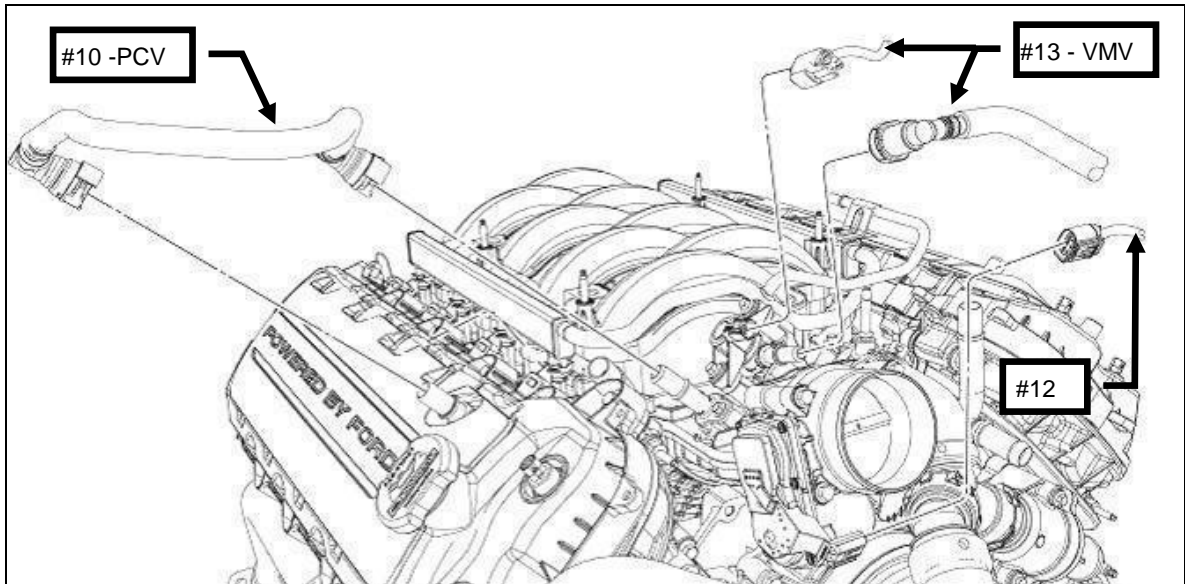

Procedures #10, 12 & 13

14. Disconnect the fuel supply hose from the fuel rail. Refer to #14 in figure shown below.
15. Disconnect the brake booster vacuum hose from the intake manifold. This port is located directly behind the throttle body. Refer to #15 in figure shown below.

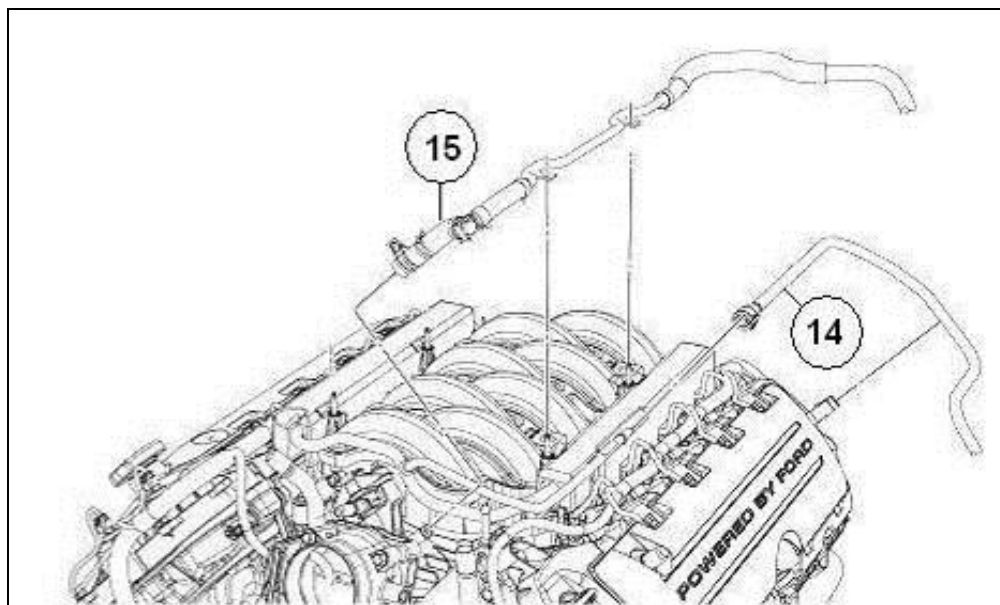

Procedures # 14 -15



ROUSH[®]
P E R F O R M A N C E

PREMIUM FUEL REQUIRED – NOT E85 COMPATIBLE

16. Remove the 3/8" engine coolant degas hose from the connection at the engine and place the loose end of the hose to the side for later connection.
17. Carefully detach the four (4) wiring harness retainers from the rear of the intake manifold. The two "outer" clips will be reused once the new manifold is installed to retain the harness.

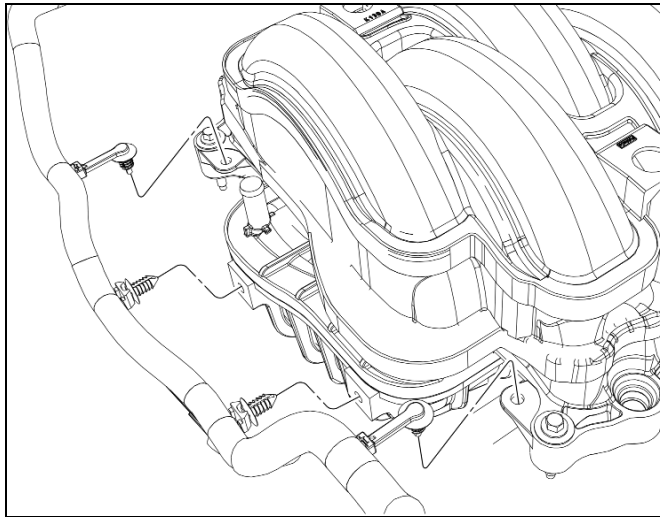

18. Remove and discard the LH and RH fuel rail insulators. Disconnect the eight (8) fuel injector electrical connectors.
19. Remove the four (4) fuel rail bolts. **These bolts will be reused.** **NOTE:** It is not necessary to remove the fuel rail from the intake manifold assembly.
20. Remove the remaining six (6) intake manifold mounting bolts and remove the intake manifold and fuel rail assembly from the vehicle. This hardware will not be reused.



ROUSH[®]
P E R F O R M A N C E

PREMIUM FUEL REQUIRED – NOT E85 COMPATIBLE

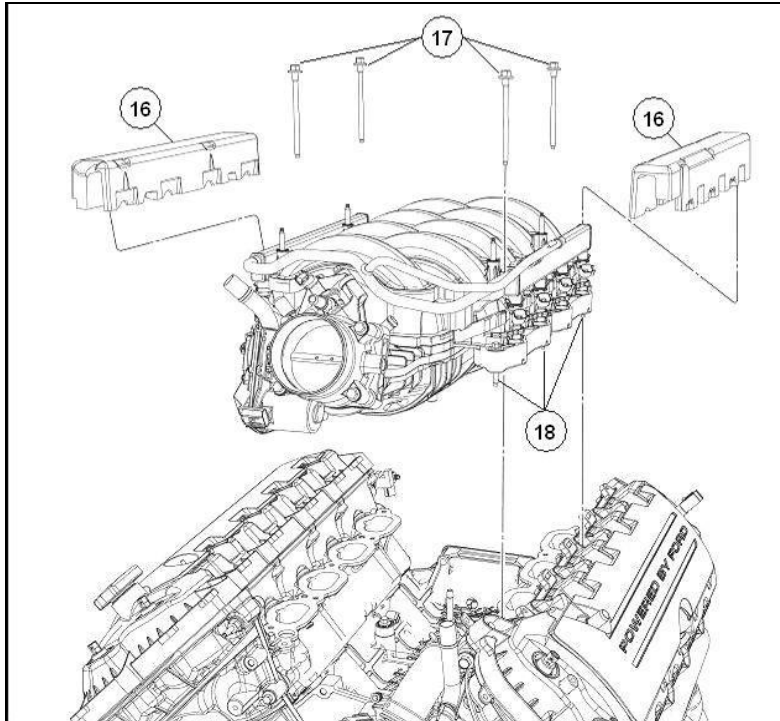

Procedures #16 - 18

21. Clean the intake mounting surfaces and apply tape over the open intake ports to prevent engine contamination.
22. Disconnect the eight (8) coil plug electrical connectors and remove the eight (8) coils from the vehicle by removing the bolt securing them to the cam covers.

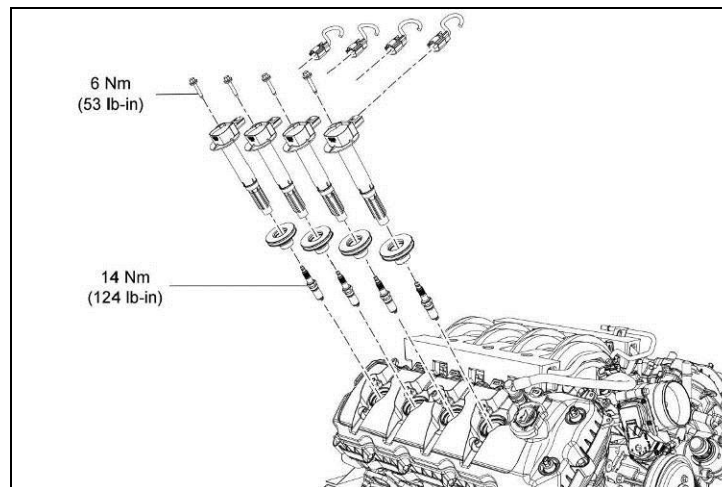



ROUSH®
P E R F O R M A N C E

PREMIUM FUEL REQUIRED – NOT E85 COMPATIBLE

23. Remove the factory spark plugs and install the new spark plugs (CYSF 12YP) provided with the kit. Torque to 14 Nm.
24. Re-install the coil on plugs and torque to 6 Nm. Connect the electrical connector to the coil on plugs in eight places.
25. Disconnect both ends of the upper radiator hose and remove from the vehicle.
26. Loosen the four water pump pulley bolts, and then remove the Front Engine Accessory Drive (FEAD) belt. Rotate the FEAD Tensioner counter-clockwise to release the belt tension and remove the belt.

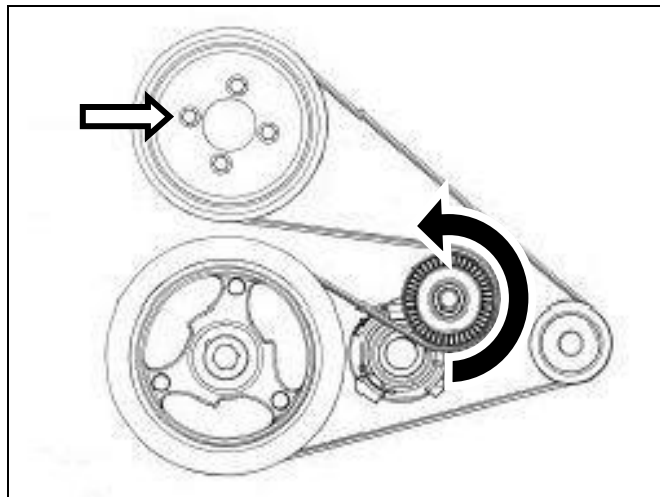

27. Remove the four (4) bolts securing the Water Pump Pulley to the engine.
28. If your truck is an early build 5.0L, cut and remove the A/C compressor belt. Discard belt.

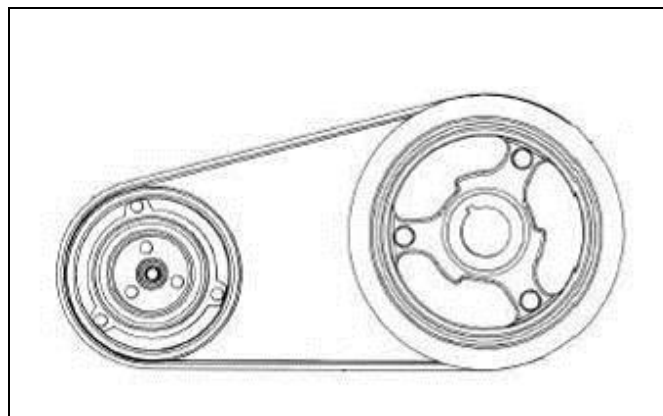



ROUSH[®]
P E R F O R M A N C E

PREMIUM FUEL REQUIRED – NOT E85 COMPATIBLE

29. If your truck is a late build 5.0L, remove the belt from this sheave and then remove the tensioner and the idler on this sheave at this time. These parts will not be re-used.

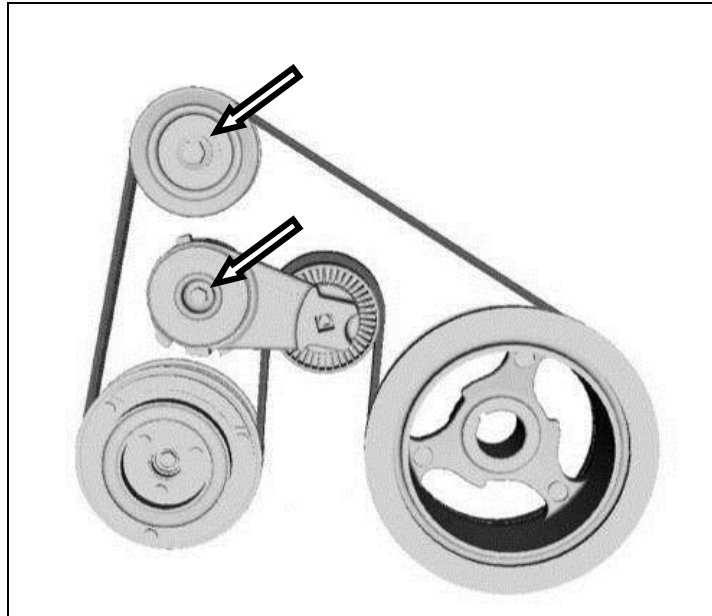

30. Remove the passenger side headlamp assembly. First remove the air deflector retainer pin to the top inside corner of the headlamp assembly. Remove the three bolts securing the headlamp and pull forward to loosen the two metal clips. Once the lamp assembly is loose, disconnect the two electrical connectors and place the lamp aside.

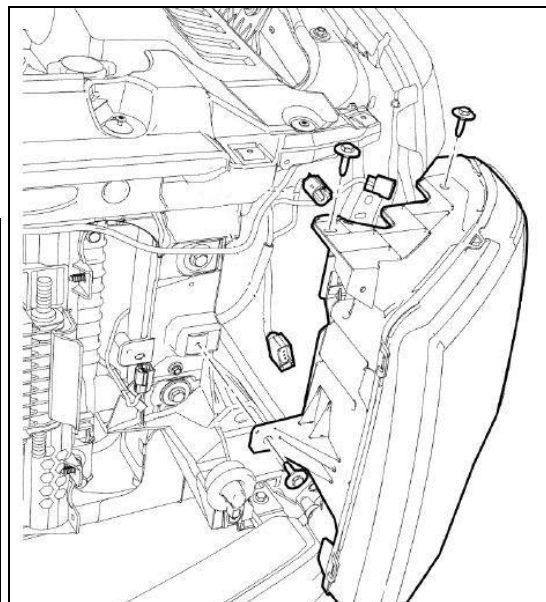
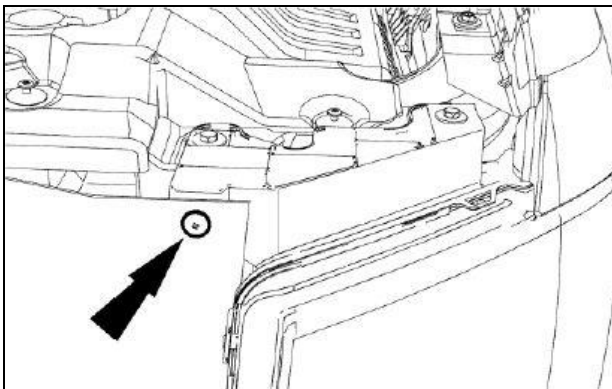



ROUSH[®]
P E R F O R M A N C E

PREMIUM FUEL REQUIRED – NOT E85 COMPATIBLE

SECTION B – MODIFICATIONS

The following section will guide you through the required modifications of existing components and build up of the assemblies used to complete the installation. With the exception of the wiring modifications, all of this work can be performed away from the vehicle.

Airbox Modification

1. Remove the MAF sensor from the stock airbox cover and install this into the new MAF tube (11SC-12B579) using the two factory fasteners. Torque screws to 1.8 – 2.2 Nm.

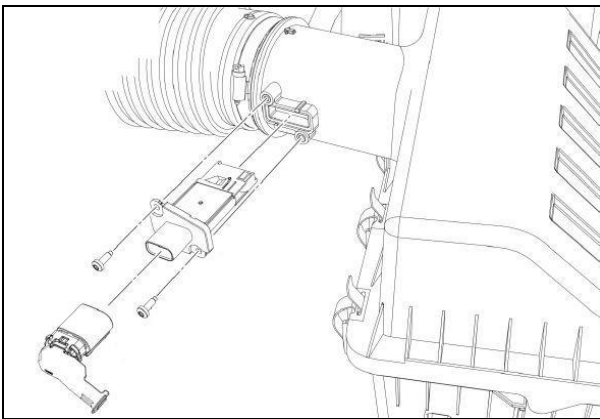

2. In order for the new airbox lid to be secured to the lower airbox tray properly, the retaining clip closest to the degas bottle needs to be modified. Remove the inboard clip from the tray and use a saw or grinder to remove part of the clip as shown. Deburr all sharp edges.

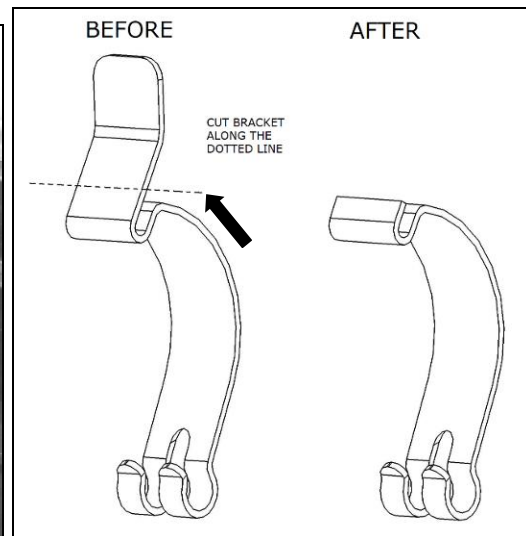
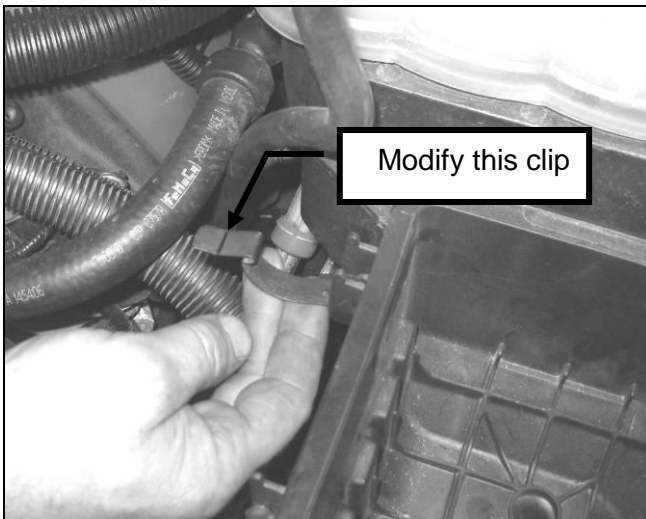



ROUSH[®]
P E R F O R M A N C E

PREMIUM FUEL REQUIRED – NOT E85 COMPATIBLE

Brake Booster Hose Modification

1. Remove the factory brake booster hose and brake aspirator assembly that is still connected to the booster.

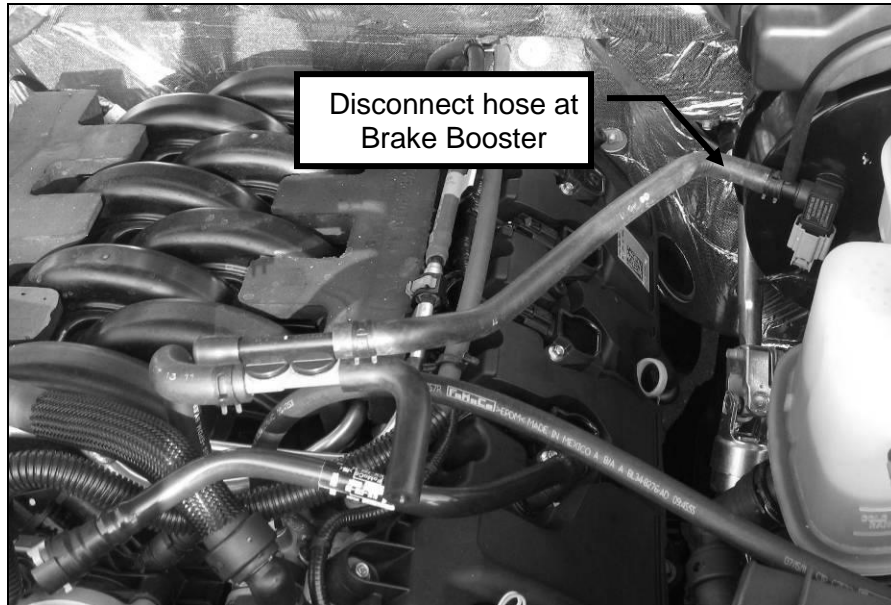



ROUSH[®]
P E R F O R M A N C E

PREMIUM FUEL REQUIRED – NOT E85 COMPATIBLE

2. Remove the short 90° hose and the long hose going to the brake booster. Switch their positions on the brake aspirator. Install the short hose opposite the black rubber cap. Place the clamps from the long hose onto the short 90° hose.

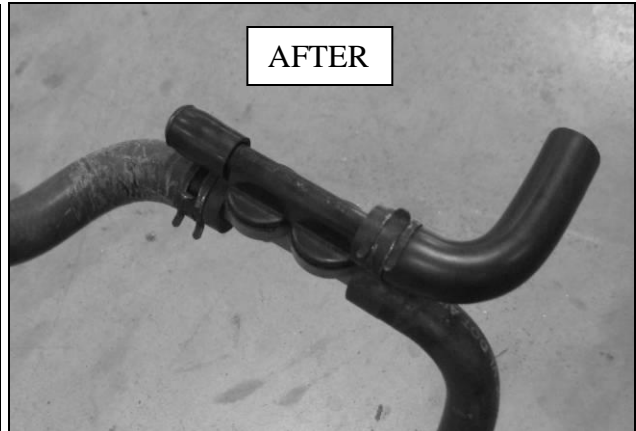
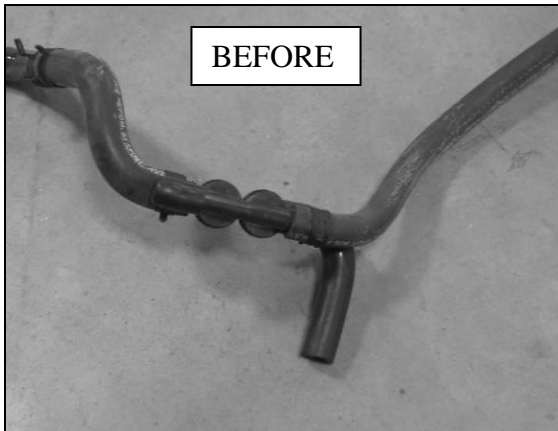
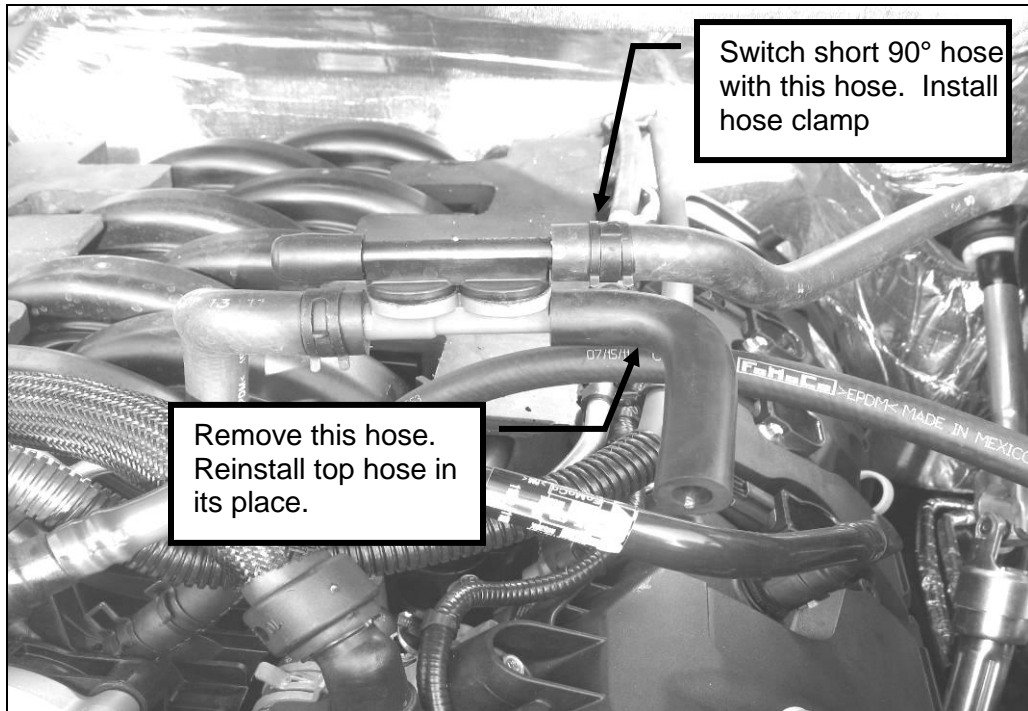



ROUSH[®]
P E R F O R M A N C E

PREMIUM FUEL REQUIRED – NOT E85 COMPATIBLE

3. Cut the short 3/8" 90° hose so it is 50mm in length after the bend and orient the 90° hose so it faces to the right as shown. Make sure to install the clamps from the long hose onto this hose.

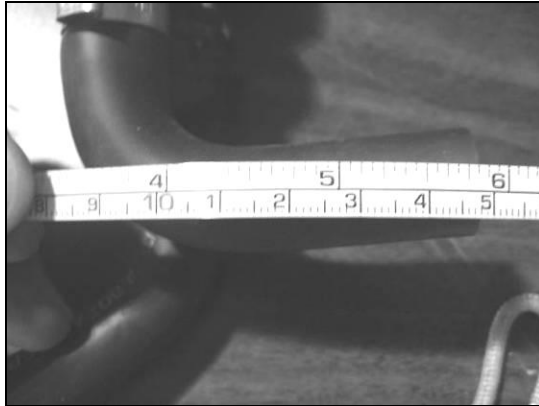

4. Cut the long 3/8" hose, (50mm from the 45° bend) and connect the straight end of the hose to the gray port on the brake aspirator. Position the hose so the 90° bend on the end points to the left.

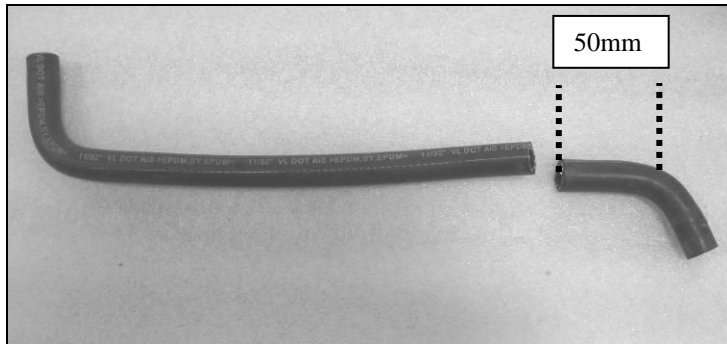



ROUSH[®]
P E R F O R M A N C E

PREMIUM FUEL REQUIRED – NOT E85 COMPATIBLE

5. Cut the larger ($\frac{1}{2}$ " diameter) hose just past the first bend. Re-install the double hose clamp and insert the $\frac{1}{2}$ " to $\frac{3}{8}$ " adapter (5463K225) into the hose. Insert the section of $\frac{3}{8}$ " cut hose from the previous step. Using two (2) worm drive clamps (62003), place one on either end of this $\frac{3}{8}$ " hose. Tighten the hose clamps to the hose. Set this hose aside as it will be connected in a later step.

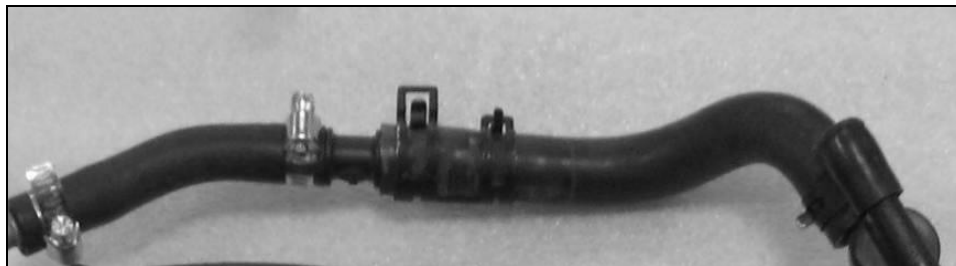

6. Cover both the $\frac{1}{2}$ " hose and the $\frac{3}{8}$ " lengths of hose with the $\frac{3}{4}$ " split loom convoluting (1312-transconv) provided. Cut the convoluting to length desired for best fitment over hoses.



ROUSH[®]
P E R F O R M A N C E

PREMIUM FUEL REQUIRED – NOT E85 COMPATIBLE

VMV Hose Modification

1. Locate the fuel vapor hose beside the fuel supply line. At the joint where the tube transitions from steel to plastic, cut the VMV line in a vertical direction and remove the covered plastic portion from the steel line fixed in the vehicle.

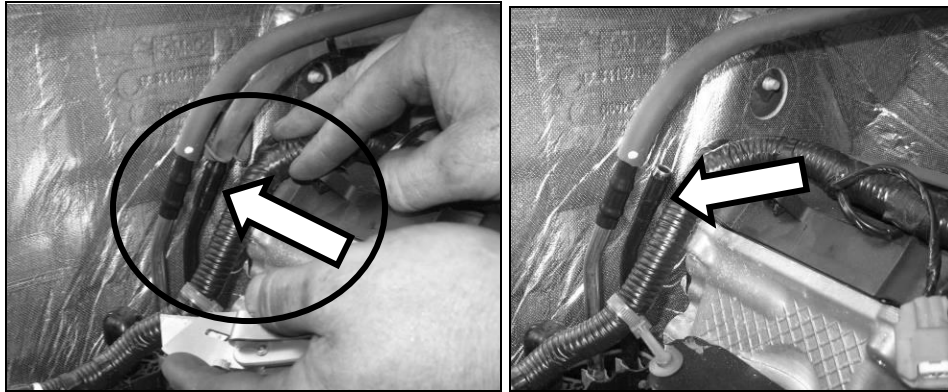

2. With the line removed from the vehicle, carefully cut along the opposite end of the hose where the fitting is inserted and remove the quick connect fitting from the hose.

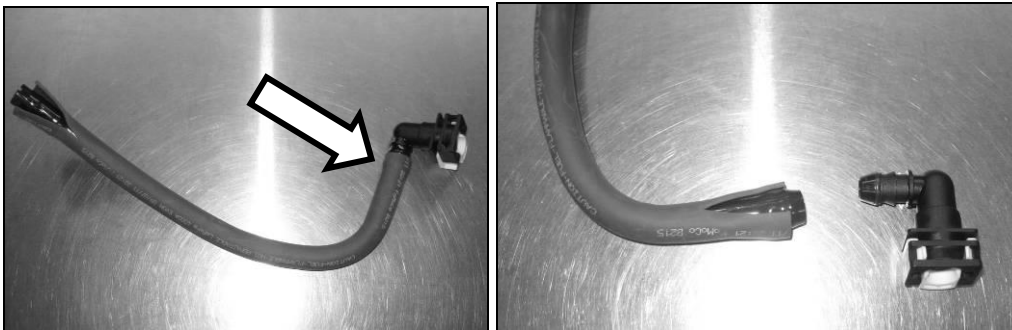

3. Install the quick connect fitting into one end of the new VMV hose (27004) and secure using one (1) worm drive clamp (62003).





ROUSH®
P E R F O R M A N C E

PREMIUM FUEL REQUIRED – NOT E85 COMPATIBLE

4. Place the second worm drive clamp (62003) over the opposite end of the new VMV hose and install onto the steel line. Position the clamp so the screw (drive) side is closest to the cylinder head and tighten the clamp.

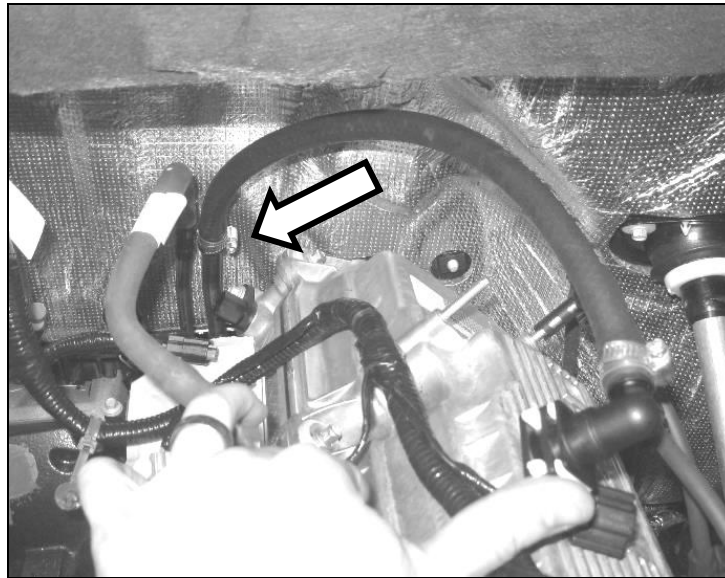

5. Remove the protective sleeve from the heater inlet hose that was previously removed from the vehicle. Insert this over the quick connect fitting and position it so it covers the clamp between the fuel supply line and the VMV line. Tape the ends of protective sleeve to keep it in position.

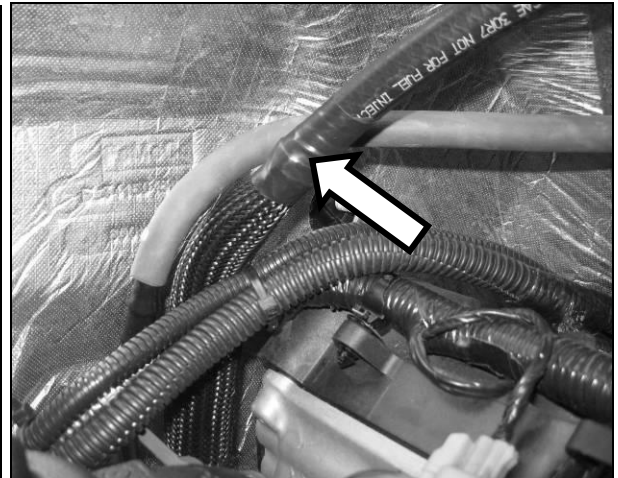
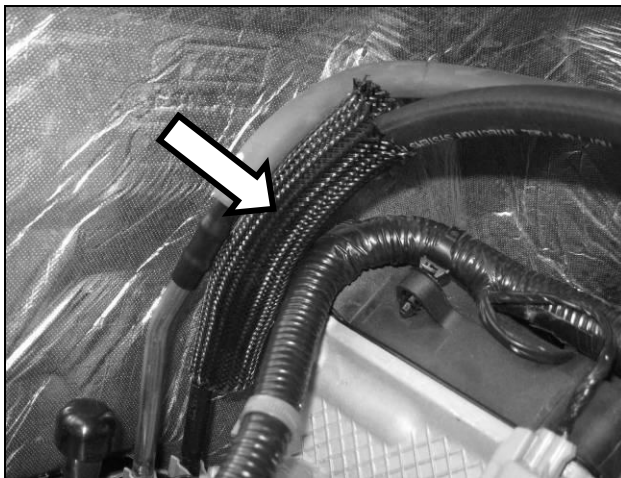



ROUSH®
P E R F O R M A N C E

PREMIUM FUEL REQUIRED – NOT E85 COMPATIBLE

Heater Hose Modification

1. With the factory heater inlet hose removed from the vehicle, cut the hose as close as possible to the 45° Quick Connect fitting as shown.



2. Cut the hose approximately 50 mm (2 inches) after the 2nd bend as shown.

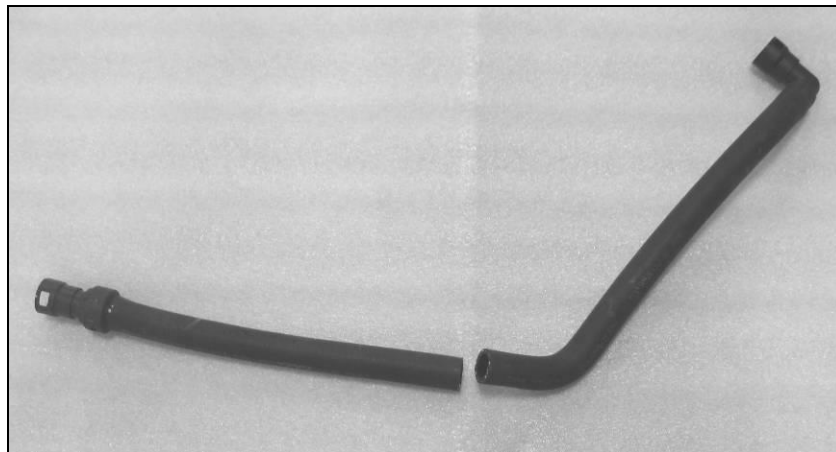

3. Insert the new 90° Quick Connect fitting in the new Heater Hose Kit (1150-18K579) and install one clamp to retain it.

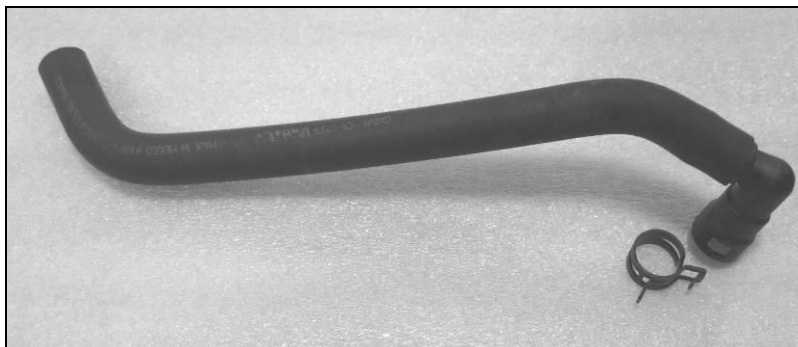



ROUSH[®]
P E R F O R M A N C E

PREMIUM FUEL REQUIRED – NOT E85 COMPATIBLE

4. Insert the length of hose with the $\frac{3}{4}$ " x $\frac{3}{4}$ " fitting into the opposite end of this hose and secure in place using one clamp.



5. Install the protective hose sleeve (cut to desired length) onto the front portion of the hose (from the hose connector to the 90° fitting). Tape both ends to the hose to keep from fraying.





ROUSH[®]
P E R F O R M A N C E

PREMIUM FUEL REQUIRED – NOT E85 COMPATIBLE

Front Cover Modification

1. Using a grinder or cut off wheel, modify the front cover in the areas shown. The two bosses located at A & B need to be reduced in height such that they are flush, or 2mm off of the front cover surface. The boss located at C needs to be reduced in height and cut in half.

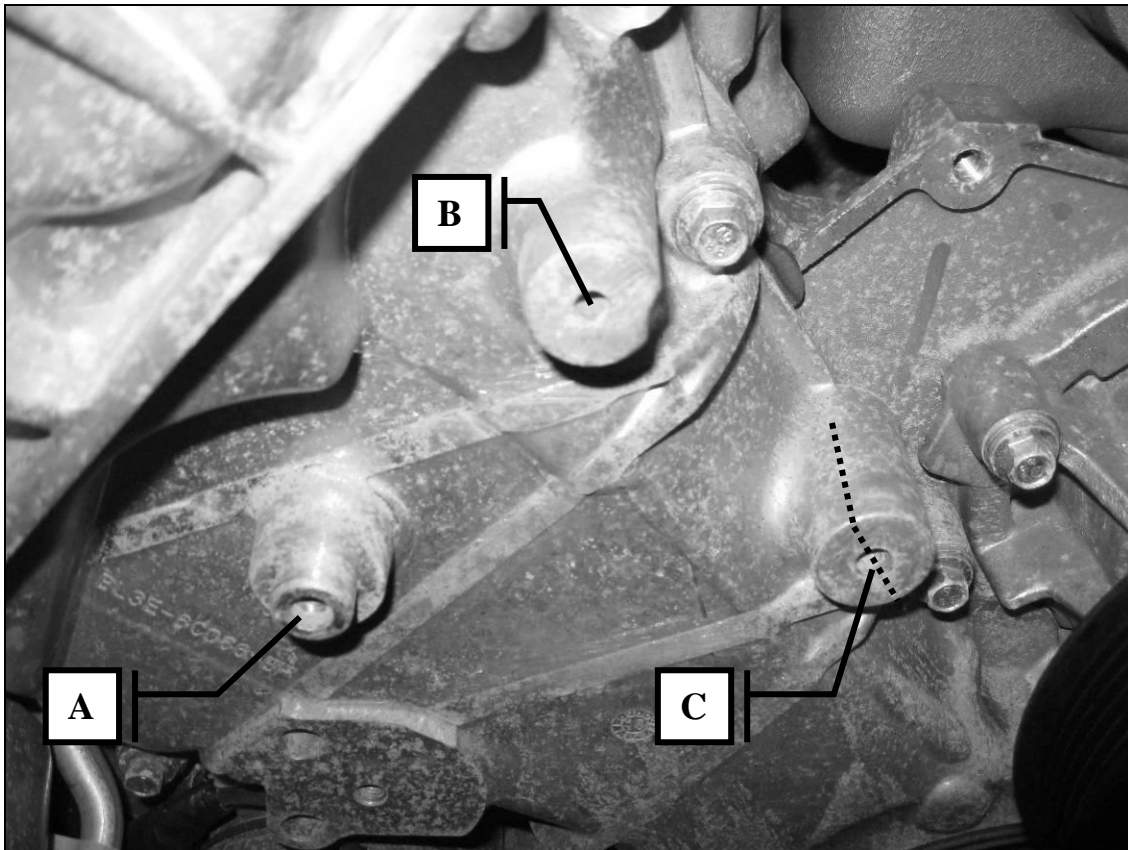



ROUSH[®]
P E R F O R M A N C E

PREMIUM FUEL REQUIRED – NOT E85 COMPATIBLE

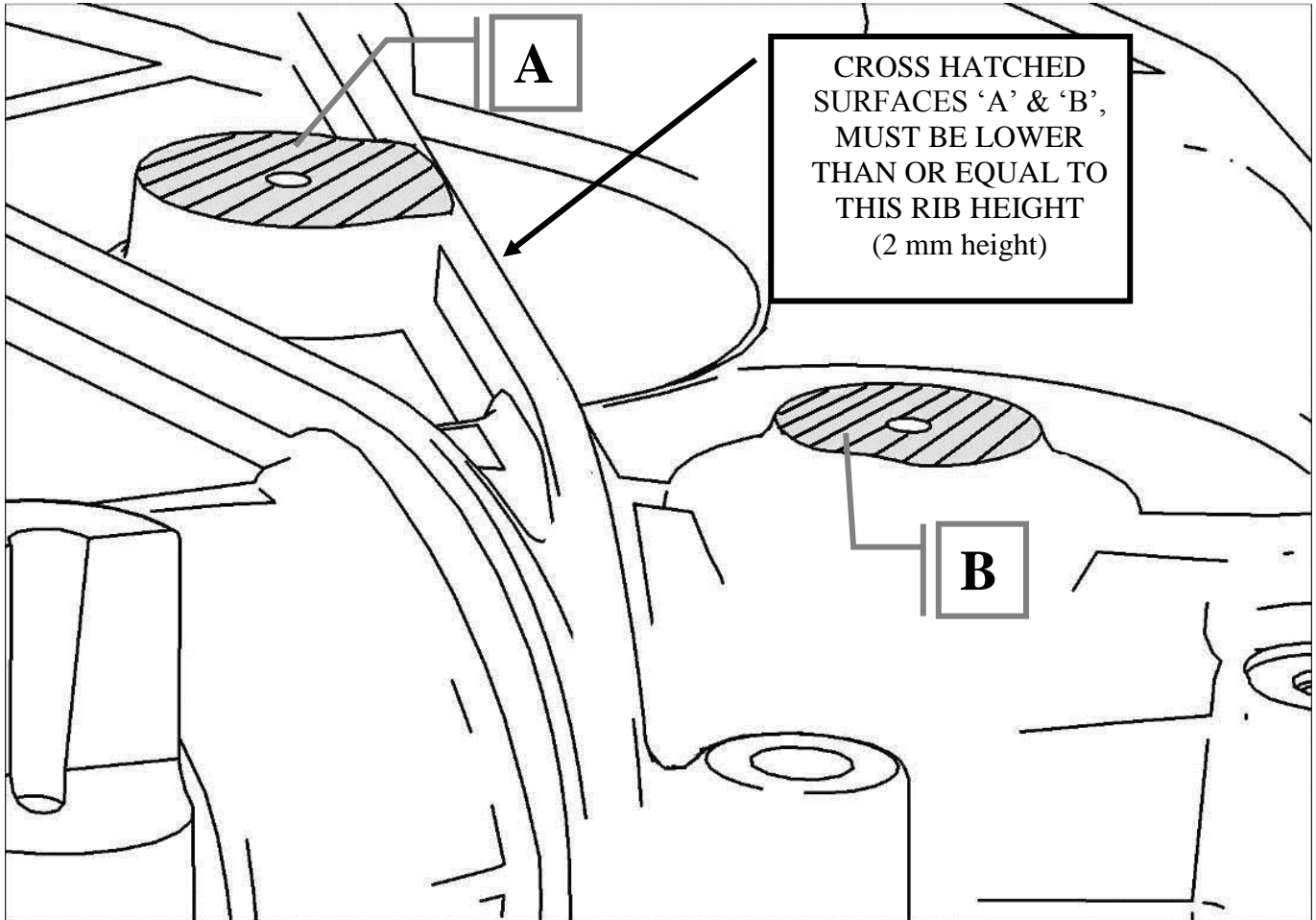



ROUSH[®]
P E R F O R M A N C E

PREMIUM FUEL REQUIRED – NOT E85 COMPATIBLE

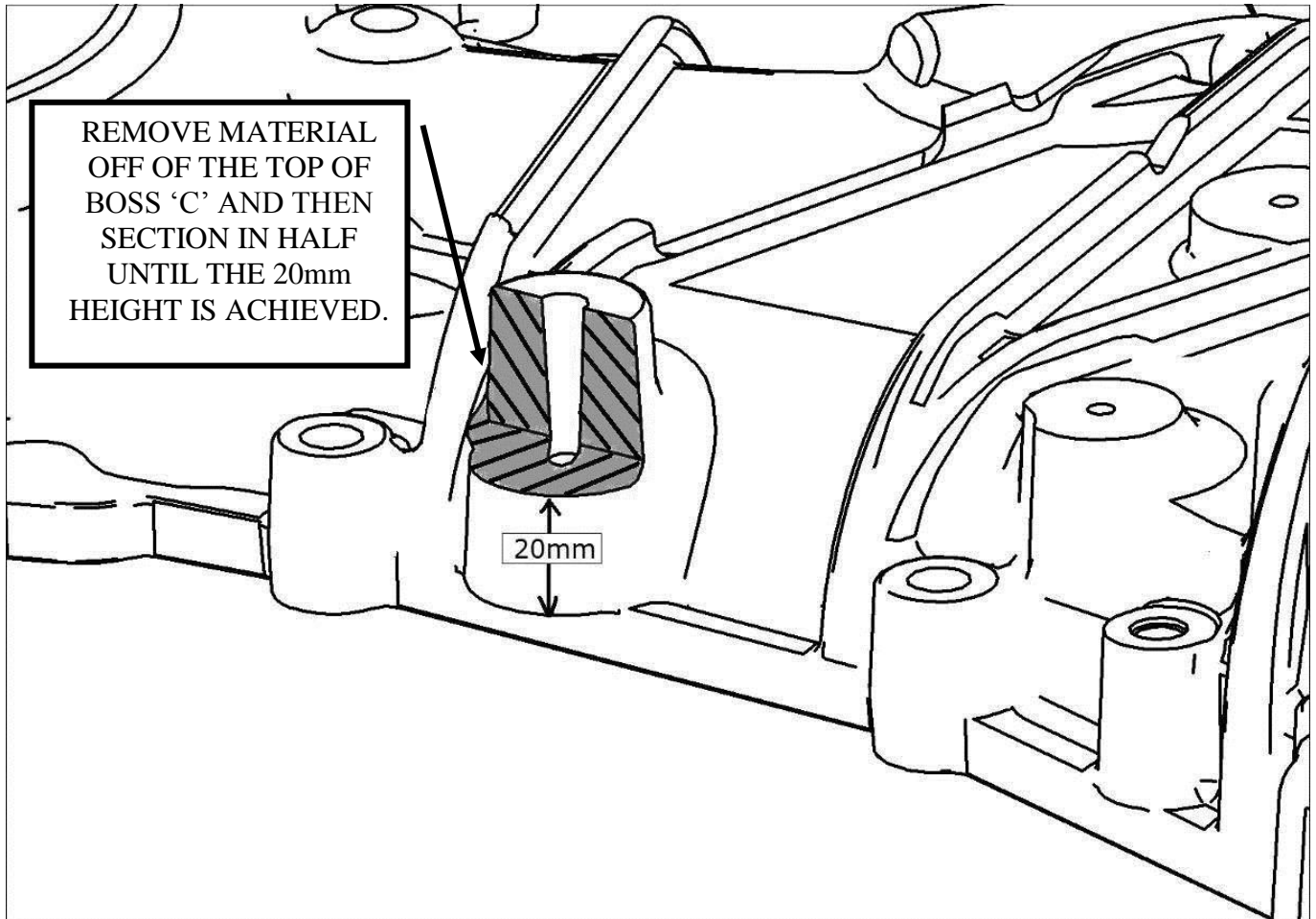



ROUSH®
P E R F O R M A N C E

PREMIUM FUEL REQUIRED – NOT E85 COMPATIBLE

Cowl Modification

1. Remove the one (1) center push pin that retain the cowl insulator pad and the four (4) bolts that retain the cowl cover.

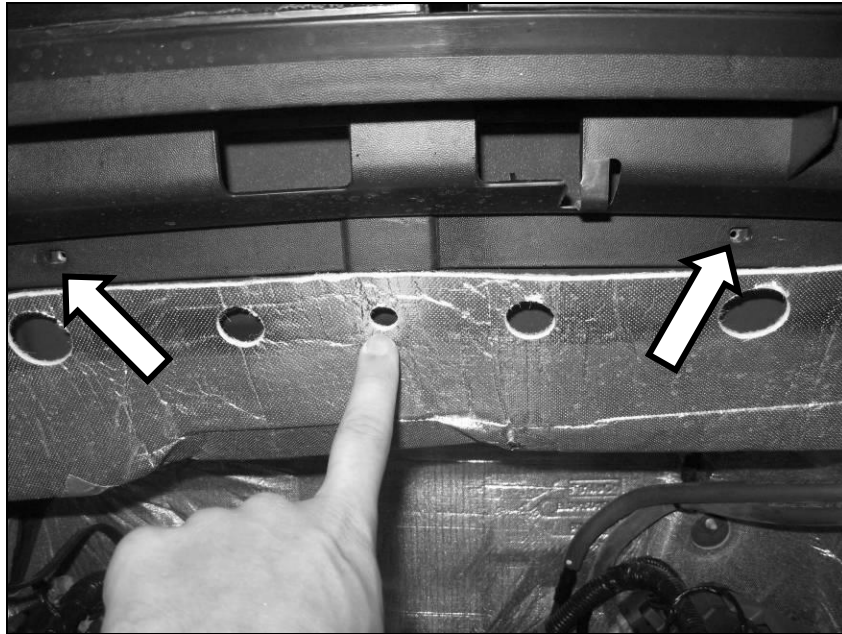

2. Gently pull the insulator pad down and fold it over so it is resting on top of the engine out of the way. Tip: Lay an object on top of the pad to keep it from springing back into position.

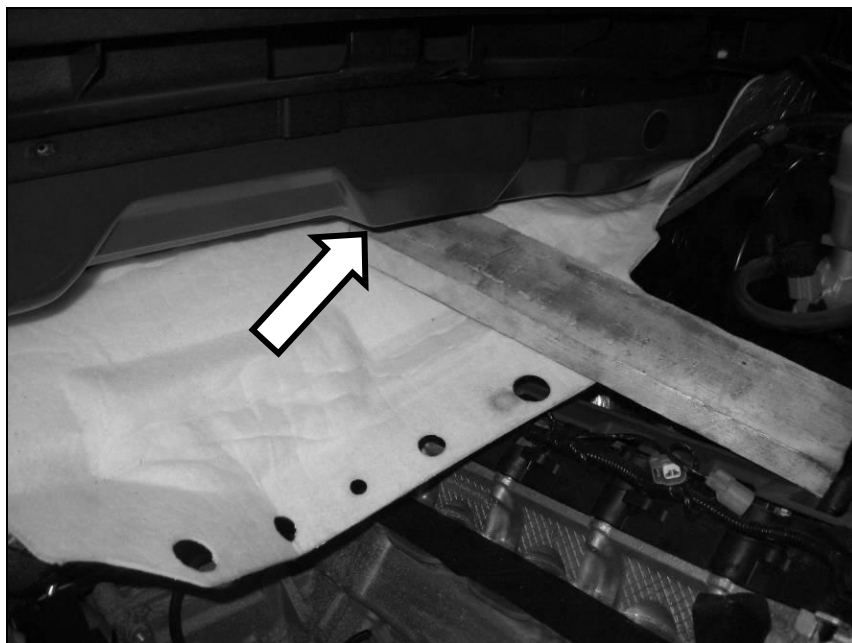



ROUSH[®]
P E R F O R M A N C E

PREMIUM FUEL REQUIRED – NOT E85 COMPATIBLE

3. Using a small mallet, hit the corner of the cowl in the area circled. This is done to give the engine enough clearance as not to contact the cowl while the engine moves during normal usage.



4. It is recommended that you apply some trim adhesive to the back of the insulator pad and then re-install the insulator pad into position underneath the cowl cover.



5. Re-install the one (1) push pin that retains the cowl insulator pad and re-install the four (4) bolts that retain the cowl cover.



ROUSH[®]
P E R F O R M A N C E

PREMIUM FUEL REQUIRED – NOT E85 COMPATIBLE

TPS/ETC Wiring

1. Locate the Throttle Position Sensor (TPS) connector and harness at the front of the passenger side cylinder head. Use a proper de-pinning tool to remove the connector from the harness.

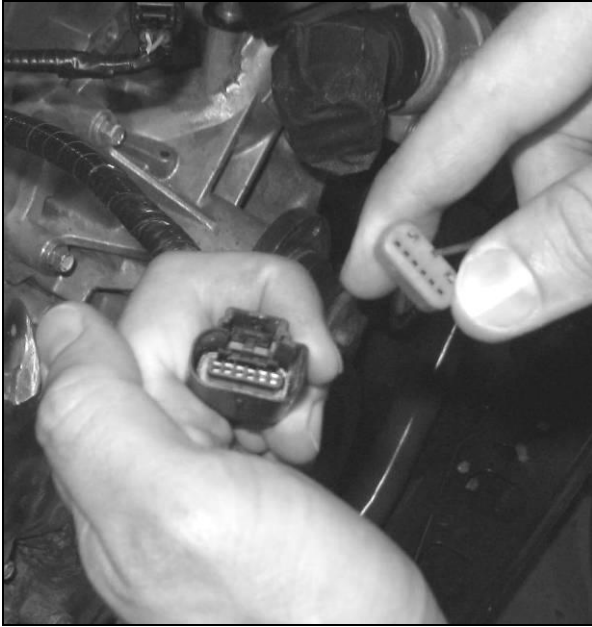

2. Depress the locking tab and separate the “empty” female 1 x 6 connector from the new TPS/ETC Extension harness (131114A595). It will be used in the next step.





ROUSH®
P E R F O R M A N C E

PREMIUM FUEL REQUIRED – NOT E85 COMPATIBLE

3. Populate the new connector such that the yellow with violet wire is in position 1, the blue with green wire is in position 2, the brown wire is in position 3, the blue with orange wire is in position 4, the yellow wire is in position 5 and the green with violet wire is in position 6. Install the red plastic lock into the connector to secure the wires in place.

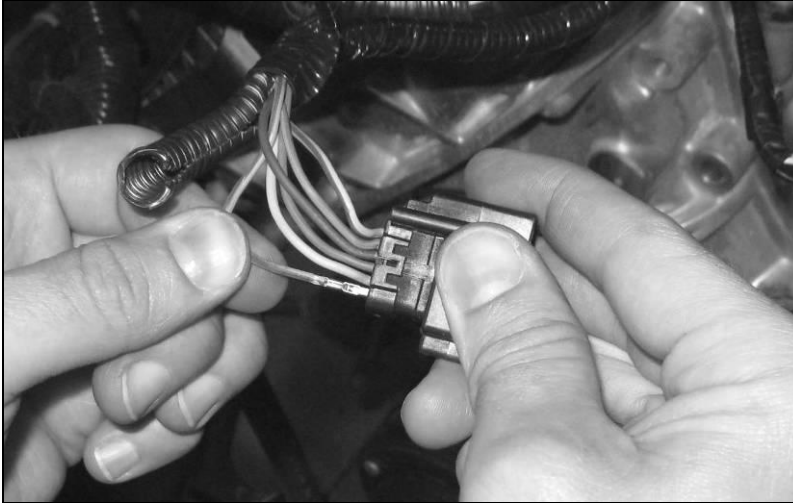

4. Connect the TPS/ETC extension harness to the newly installed connector. The wire colors on each side of the connector pair should align. Route the harness along the main wiring harness to the rear of the driver side cam cover. Use tape or zip ties to secure the extension harness to the main harness.





ROUSH[®]
P E R F O R M A N C E

PREMIUM FUEL REQUIRED – NOT E85 COMPATIBLE

Canister Purge Valve Wiring

1. Locate the Canister Purge Valve electrical connector at the front of the passenger side cylinder head. Remove and discard the 90 degree wire retainer. Use a proper de-pinning tool to remove the connector from the harness.

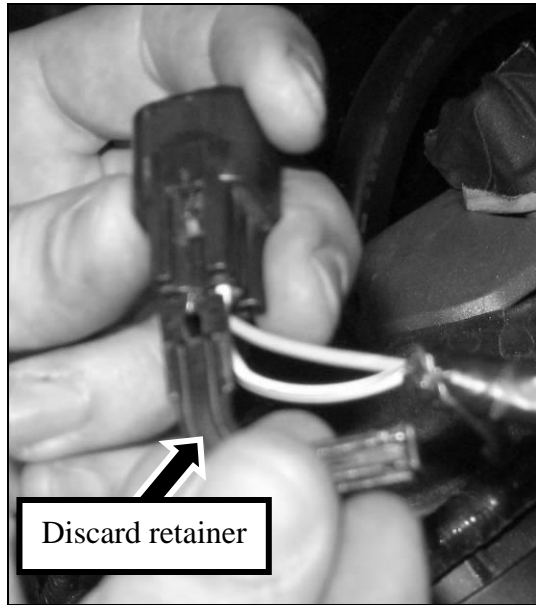

2. Depress the locking tab and separate the “empty” female 1 x 2 connector from the Canister Purge Valve Extension harness (13119G866). This connector replaces the connector removed in the previous step. **Carefully pull the white locking tab forward to allow wires to be installed into the connector.** Populate the new connector such that the white with brown wire is in position 1 and the green wire is in position 2. Depress the white locking tab to secure the wires.



ROUSH[®]
P E R F O R M A N C E

PREMIUM FUEL REQUIRED – NOT E85 COMPATIBLE



3. Connect the Canister Purge Valve Extension harness to the newly installed connector. The wire colors on each side of the connector pair should align. Route the harness along the main wiring harness to the rear of the driver side cam cover. Use tape or zip ties to secure the extension harness to the main harness.





ROUSH®
P E R F O R M A N C E

PREMIUM FUEL REQUIRED – NOT E85 COMPATIBLE

Intercooler Pump Wiring

1. With the battery removed, insert the M6 x 20 bolt (W500214) found in Hardware Kit D (11SC-TVSHKD) through the hole in the front corner of the battery box from the inside facing out.

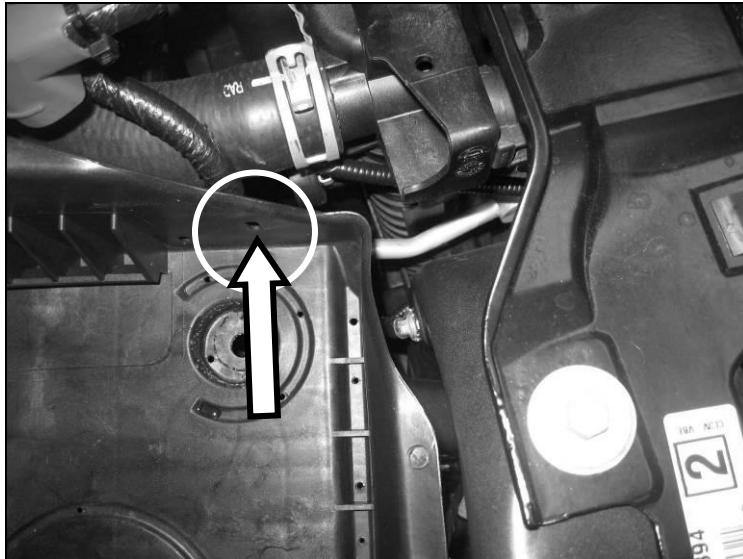

2. Install the relay from the Intercooler Pump Wiring Harness (13118W501) onto this bolt. Install the fuse on top of the relay onto the same bolt. Use the one (1) M6 nut (W520412) from the Intercooler Hardware Kit (11SC-TVSHKD) to secure the relay and fuse to the stud. Torque the nut to 10 Nm.

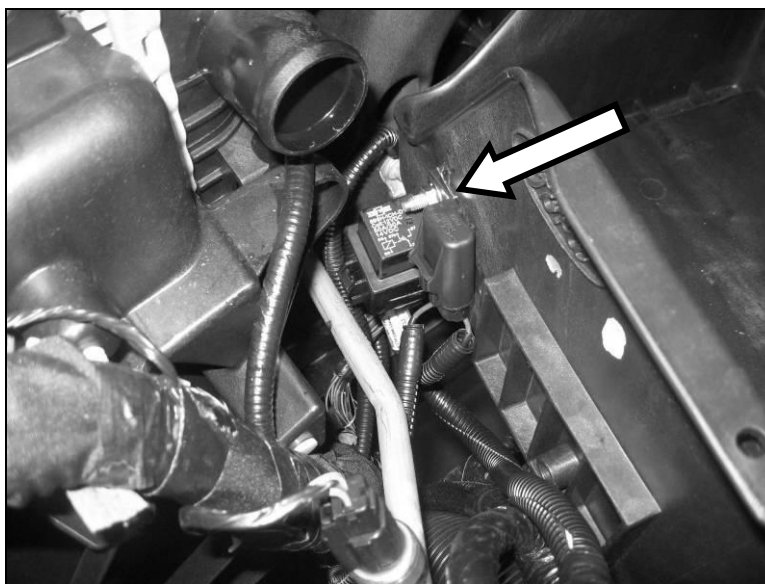



ROUSH[®]
P E R F O R M A N C E

PREMIUM FUEL REQUIRED – NOT E85 COMPATIBLE

3. Route the black ground wire coming from the relay toward the front radiator support. Remove the one (1) bolt securing the factory ground wire to the chassis along the radiator support. Insert the black ground wire from the I/C Pump harness and replace the bolt to secure the factory grounds including the grounding eyelet from with the intercooler pump harness. TIP: Access this bolt through the front opening where the headlamp assembly was.

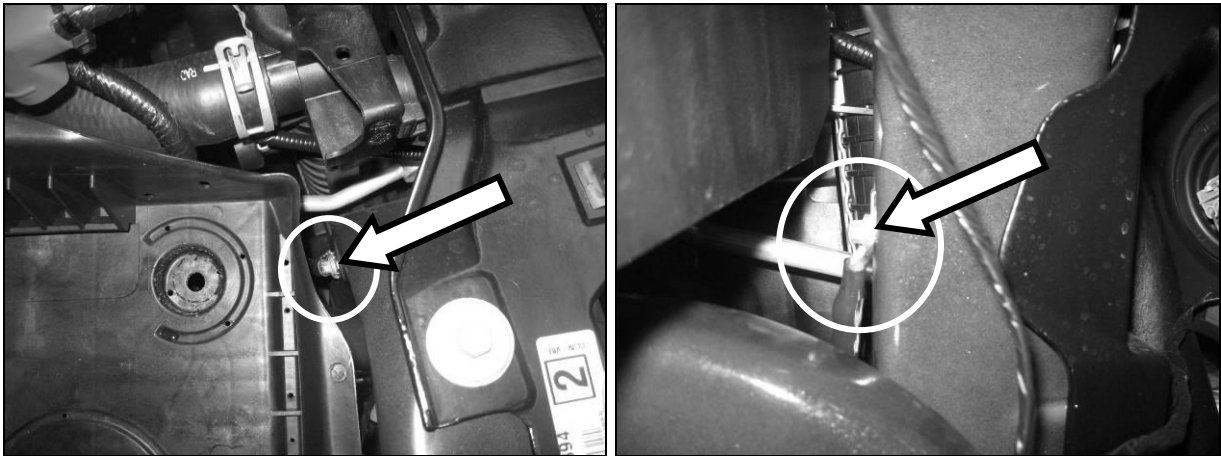

4. Route the red wire (part of the Intercooler Pump Wiring Harness installed above) to the positive terminal of the battery cable. Remove the nut from the positive terminal and install the red wire eyelet. Reinstall the nut onto the terminal. Torque to 10 Nm.

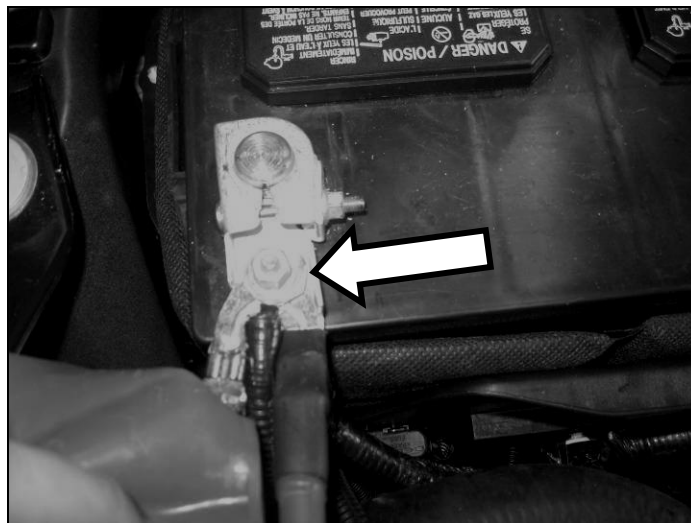

5. Route the single wire with the two electrical connectors along the factory engine harness to the rear of the passenger side cylinder head. Connect these two connectors inline with the passenger side radio capacitor. The single connector will be routed to the intercooler pump in Section D of this manual.



ROUSH[®]
P E R F O R M A N C E

PREMIUM FUEL REQUIRED – NOT E85 COMPATIBLE

Air Charge Temperature (ACT) Wiring

1. You will be working with the far left 70 pin or "cowl" connector. (See figure 1 below).

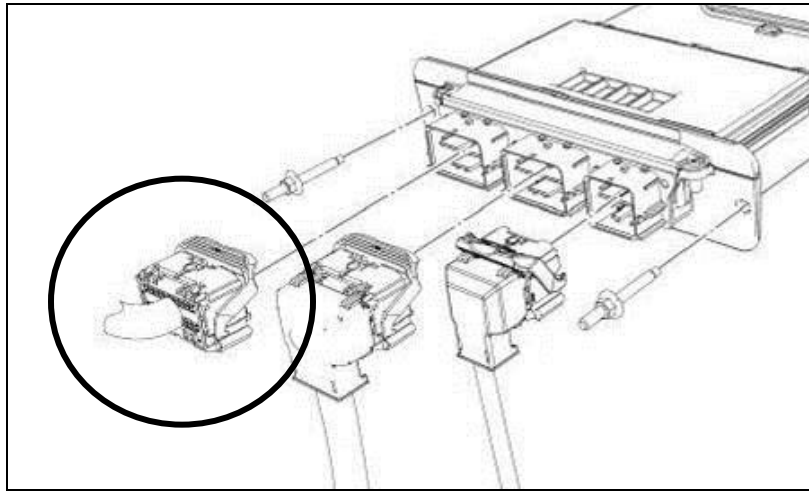

Figure 1

2. a) Remove the pin locking device as shown in figures 2 and 3. Also remove the wire support on the back of the connector (figure 5) by removing the tape and using a small screwdriver to lift the locking tabs.



Figure 2

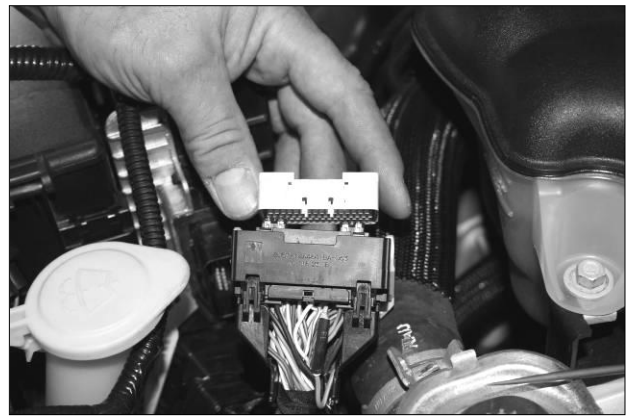

Figure 3



ROUSH
P E R F O R M A N C E

PREMIUM FUEL REQUIRED – NOT E85 COMPATIBLE

The ACT Harness (131112A690) will have the ACT sensor connector at one end. On the other end will be 2 wires, one with a blunt end and the other with a pin already crimped on. The blunt wire will be spliced into the wire located in pin C-56 of the cowl connector. The wire with the pin will be inserted into location C-36 of the cowl connector. There are small numbers on the back of the connector noting location. Figure 4 below will also help to identify the pin locations.

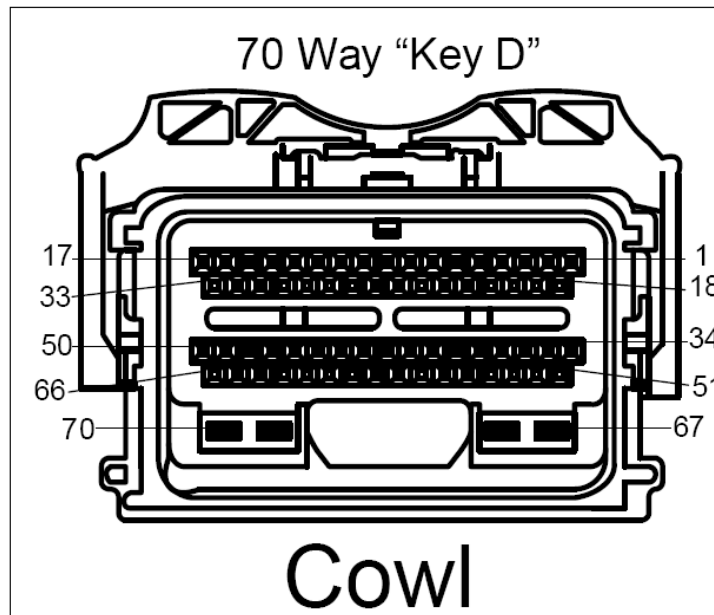

Figure 4: PCM Pin Locations for Cowl Connector – Front View (side that connects to PCM)

b) Remove pin C-56 from the connector by **gently** moving the locking tab away from the pin on the front of the connector and pulling the wire out of the back of the connector. Remove the insulation from a 1/2" section of the pin C-56 wire and 1/2" of the end of the blunt wire on the ACT loom. Solder the two wires together and seal them with the supplied shrink wrap. Reinsert the spliced wire into the C-56 location. Note the orientation of the pins on the front of the connector and reinstall the pin in the same way. If the pin is turned it will not lock. The finished/inserted splice is shown in figures 5 and 6.



ROUSH[®]
P E R F O R M A N C E

PREMIUM FUEL REQUIRED – NOT E85 COMPATIBLE

c) Insert the ACT loom wire with the pin into the empty C-36 location of the connector. The back of the connector may have a blank cover at the C-36 location. **Carefully** push this blank cover in with a small screw driver or punch to allow you to insert the pin. Note the orientation of the pins on the front of the connector and install the new pin in the same way.

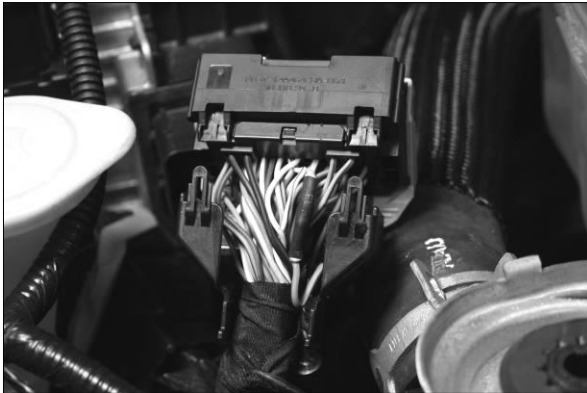

Figure 5

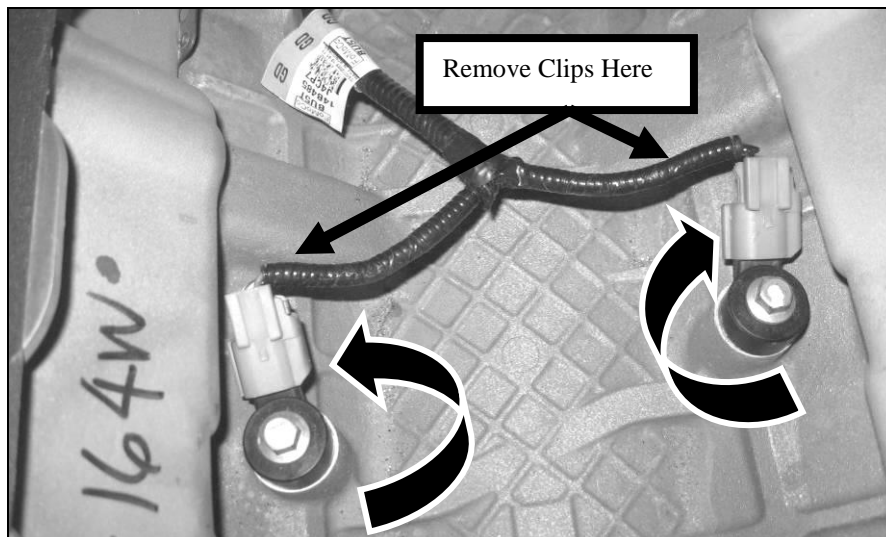

Figure 6

3. a) Reinstall the pin locking device by snapping it into place. Reinstall the wire support on the back of the connector and wrap with tape as before.
- b) Reconnect the PCM connector and route the ACT loom wire along the engine harness over to the PCM

Knock Sensor Orientation Adjustment

1. Loosen the two bolts which retain the knock sensors to the engine block and rotate the RH and LH knock sensor toward the RH and LH cylinder heads respectively. In order to do so, first remove the 90 degree plastic wiring retainer clipped to the connector and taped to the wiring convolute. Torque the knock sensor bolts to 25Nm.





ROUSH[®]
P E R F O R M A N C E

PREMIUM FUEL REQUIRED – NOT E85 COMPATIBLE

SECTION C – SUBASSEMBLY

Intercooler Low Temperature Radiator (LTR)

1. Position the Low Temp Radiator – (LTR) (13108K229) on your workbench as shown. With the 90° fitting on your left facing up and the 90° fitting on your right facing to the right.

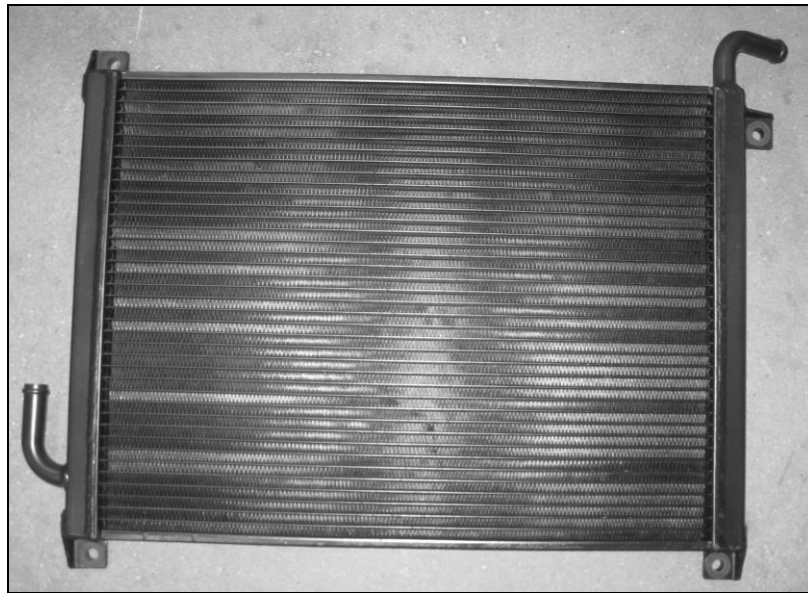

2. Insert one grommet (R07060107) into each of the four mounting holes at each corner of the LTR. With each grommet in place, position one steel grommet insert (R07060108) inside each grommet as shown. These can be found in Hardware Kit F (11SC-TVSHKF).





ROUSH[®]
P E R F O R M A N C E

PREMIUM FUEL REQUIRED – NOT E85 COMPATIBLE

3. Position each of the LTR Mounting Brackets found in Hardware Kit F (11SC-TVSHKF) into the positions as shown. Loosely install one M8 x 25 bolt (N808920) from Hardware Kit F through the front of each of the grommet inserts and secure to the weld nut on the brackets (Four places).

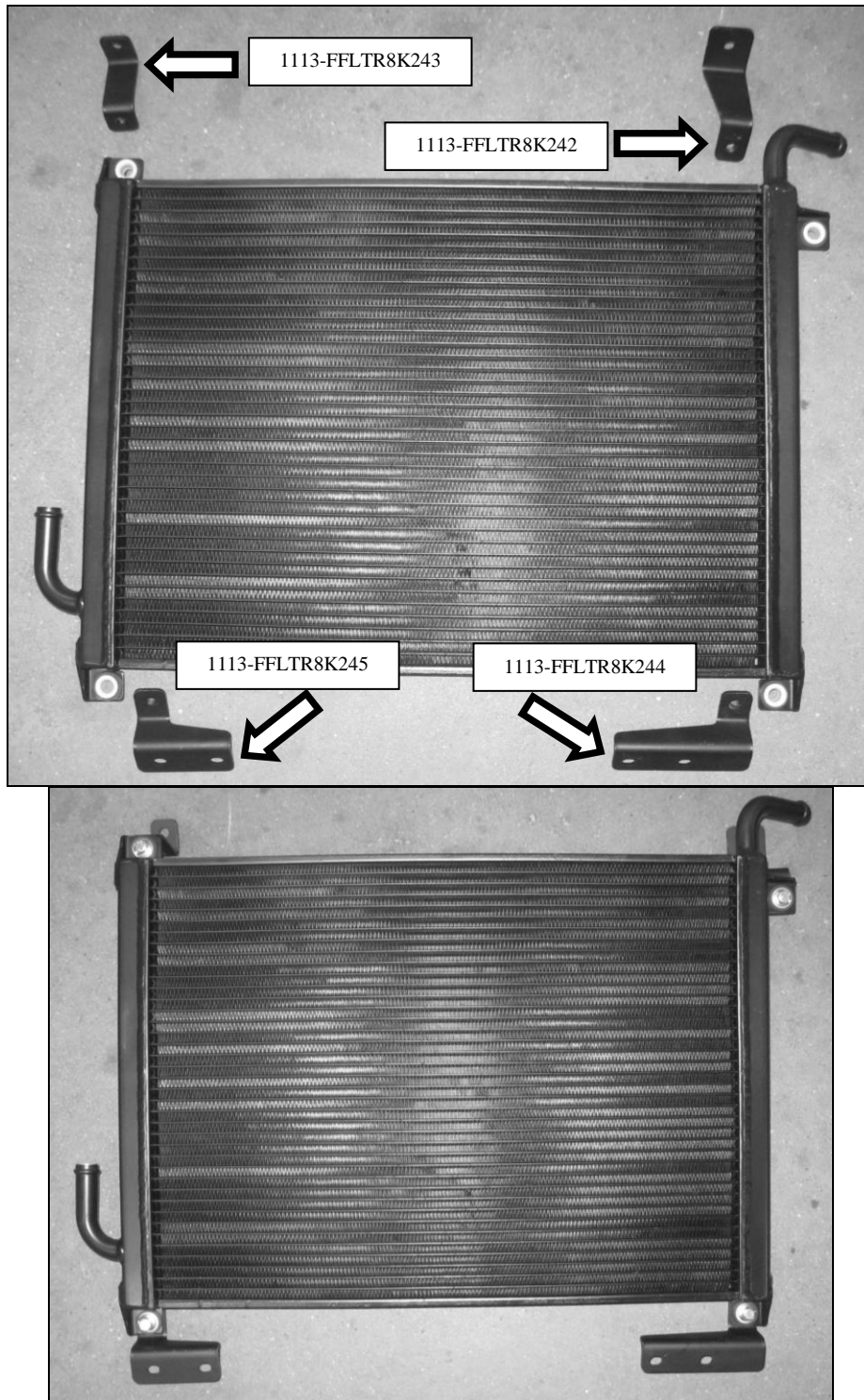



ROUSH[®]
P E R F O R M A N C E

PREMIUM FUEL REQUIRED – NOT E85 COMPATIBLE

4. Place the LTR Cross Brace (1111-8K241) on your work bench as shown. Loosely install the I/C Pump Mounting bracket (1111-8C419) to the corner of the bracket as shown using one M8 x 25 bolt (N808920) from Hardware Kit D at the top. Loosely install the Lower RH LTR Mounting Bracket (1111-8K245) to the lower RH corner of the I/C Pump Mounting bracket as shown, using one M8 x 25 bolt (N808920) from Hardware Kit D.

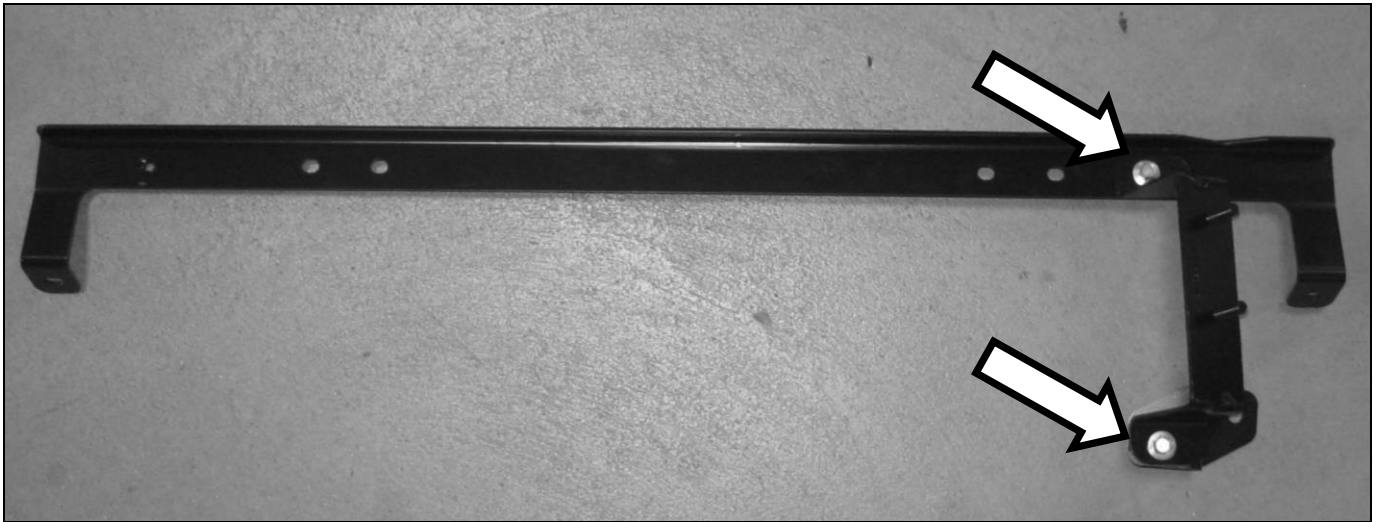

5. Install the I/C Pump (392022009) to the I/C Pump Mounting bracket and secure using two (2) M8 nuts (W520413) found in Hardware Kit D. Position the pump so the inlet is facing up. Torque the nuts to 25 Nm.

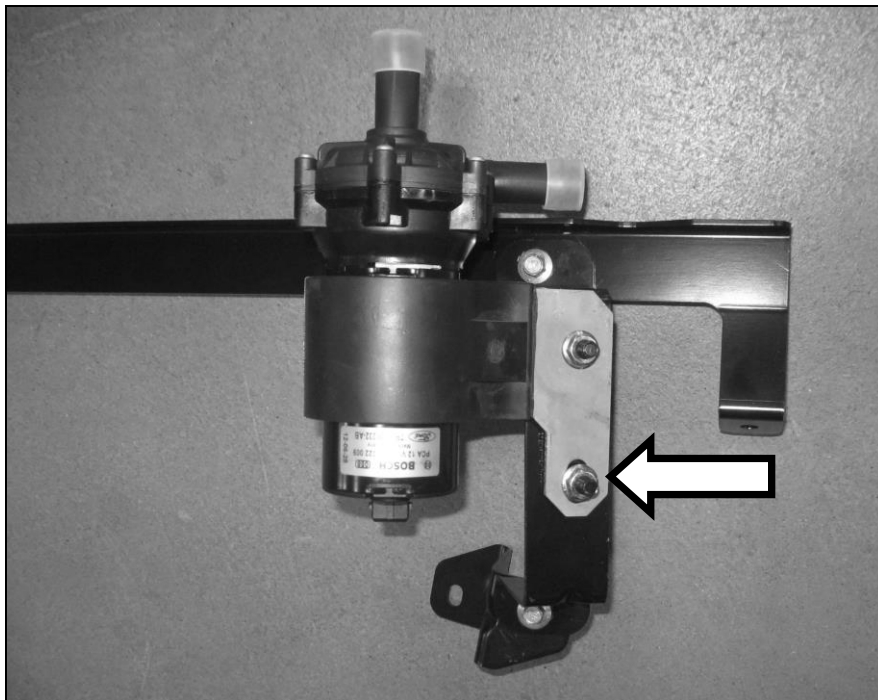



ROUSH[®]
P E R F O R M A N C E

PREMIUM FUEL REQUIRED – NOT E85 COMPATIBLE

Intake Manifold Build Up

1. Remove the Fuel Charging Assembly (13119H487) from the packaging.
2. Attach the rubber hose from the PCV Purge Hose (13116K817) to the bubbler fitting (3/8" barb) on the bottom of the fuel charging assembly and secure it with the supplied clamp.

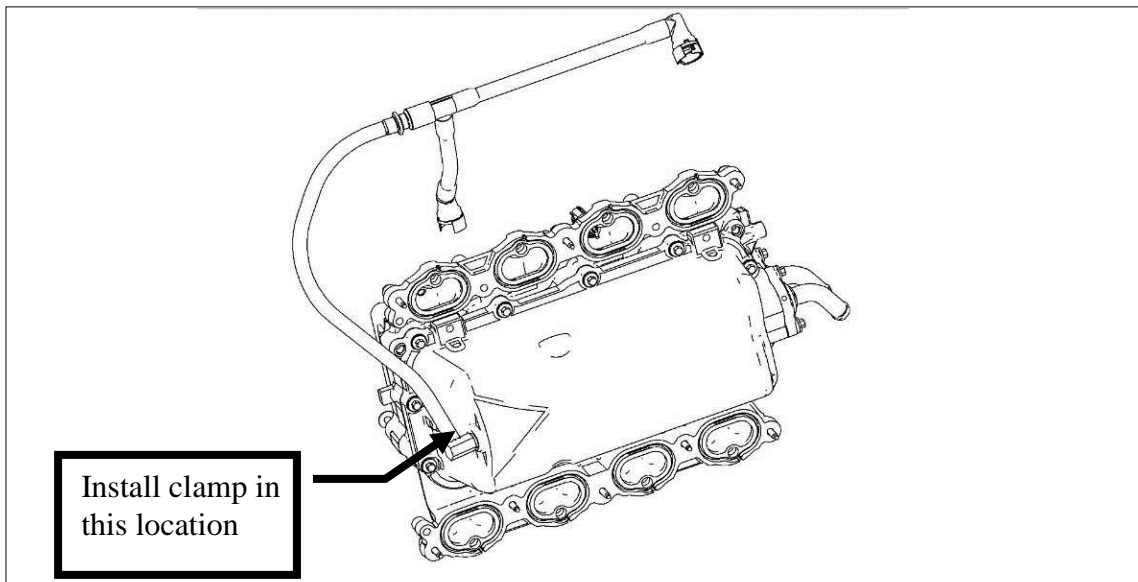



ROUSH[®]
P E R F O R M A N C E

PREMIUM FUEL REQUIRED – NOT E85 COMPATIBLE

Throttle Body Spacer Assembly

1. Remove the Evaporative Emission Canister Purge Valve from the stock intake manifold.

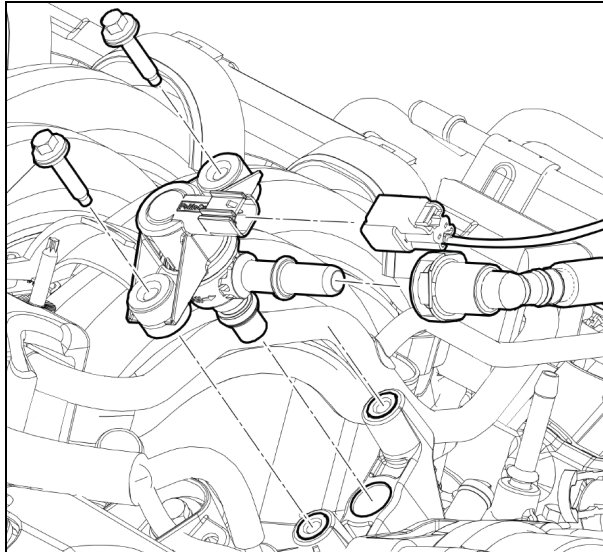

2. Install the valve into the new Throttle Body Spacer (1150-9A589) and secure using the two take off bolts. Torque bolts to 10 Nm.



3. Connect the supercharger boost bypass actuator hose (short 4" hose - R18140001) to the straight fitting on throttle spacer.





ROUSH[®]
P E R F O R M A N C E

PREMIUM FUEL REQUIRED – NOT E85 COMPATIBLE

4. Connect the modified brake booster hose to the 90° elbow on the throttle body. This will be connected to the brake aspirator once the throttle spacer is installed.

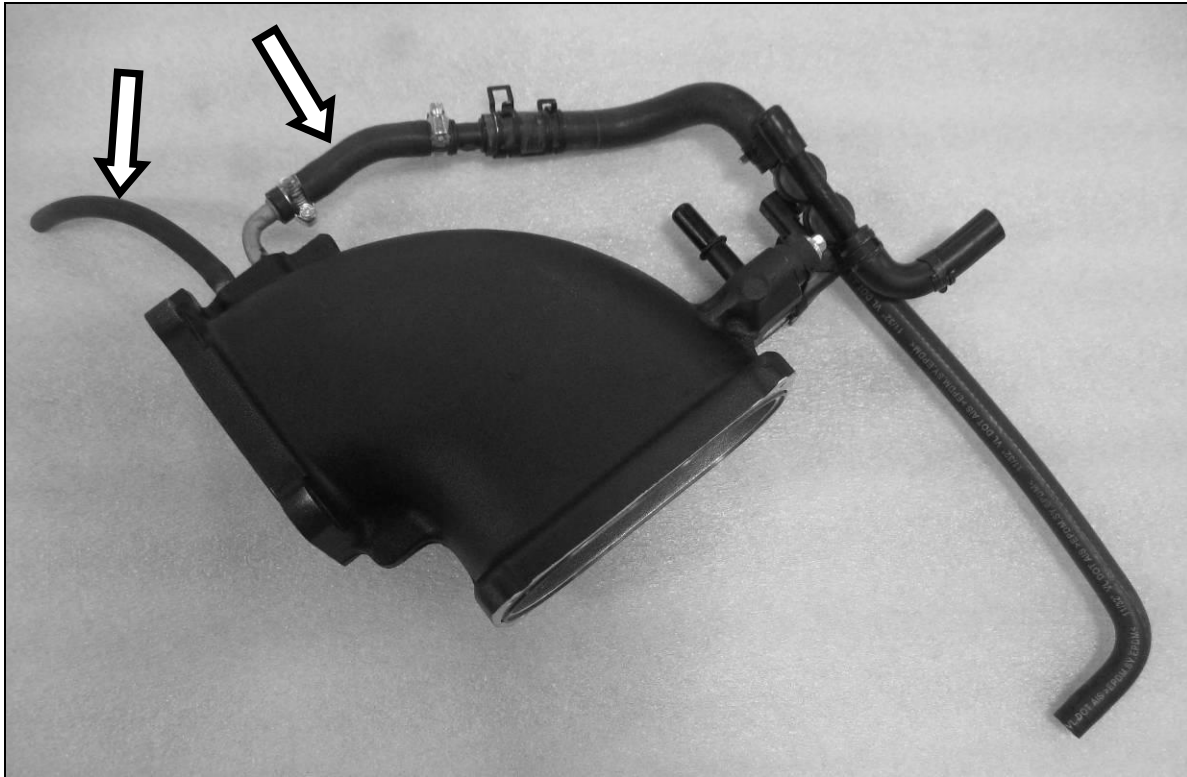



ROUSH[®]
P E R F O R M A N C E

PREMIUM FUEL REQUIRED – NOT E85 COMPATIBLE

Fuel Rail Assembly

1. Carefully install the eight (8) new Anti-Rotation Fuel Injector Clips (13119C995) onto the Fuel Injectors of your choice (not provided).

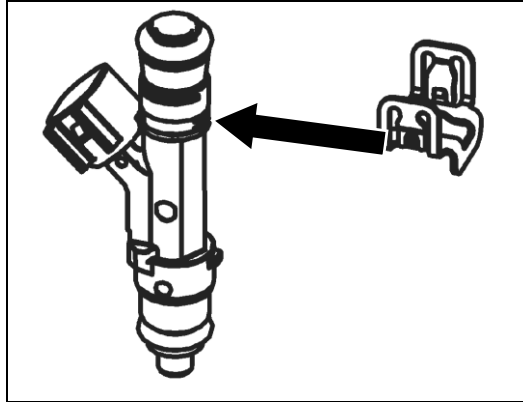

2. Apply assembly lube to the injector O-rings and install the injectors into the new Fuel Rail (13119F792). **NOTE: Verify that the anti-rotation clips are properly aligned and fully engaged into the fuel rail injector cups.**

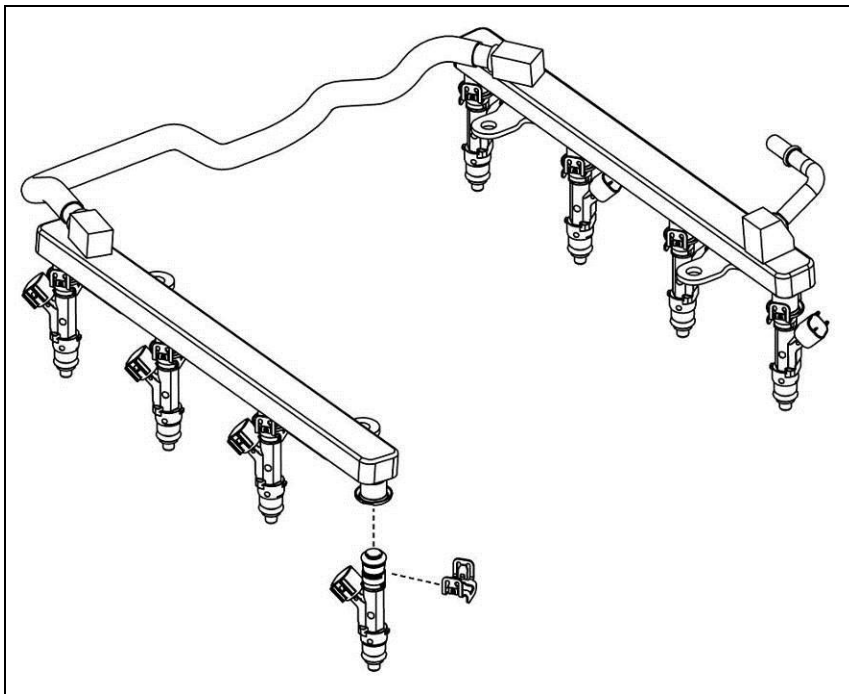



ROUSH[®]
P E R F O R M A N C E

PREMIUM FUEL REQUIRED – NOT E85 COMPATIBLE

SECTION D – INSTALLATION

The following section will guide you through the final installation of the kit into the vehicle. If you need to stop during any part of the installation, make sure you cover any open ports in the cylinder heads or intake manifold to prevent foreign material from contaminating your engine.

Intercooler Reservoir Mounting

NOTE: FORD MADE A CHANGE FOR 2014 MODEL YEAR FOLLOW THE PROPER INSTRUCTIONS BELOW.

1. Remove the two RH (Passenger Side) front strut mounting nuts shown (2011-2013).

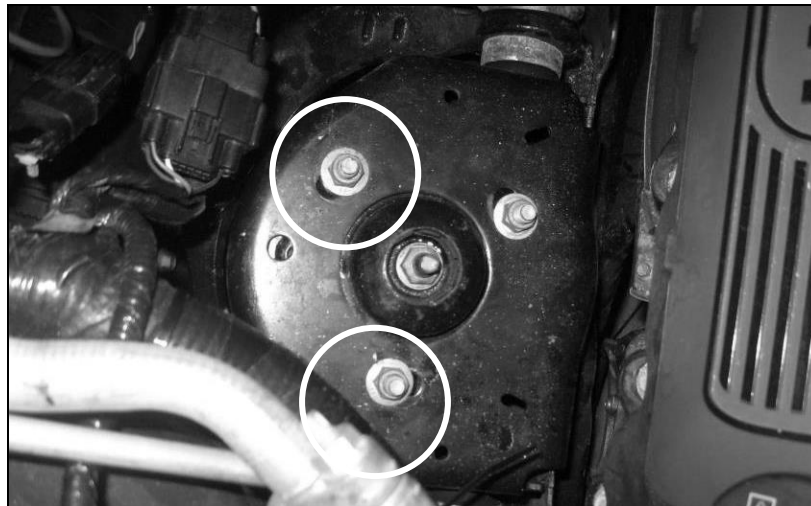

For 2014, remove the nuts shown.

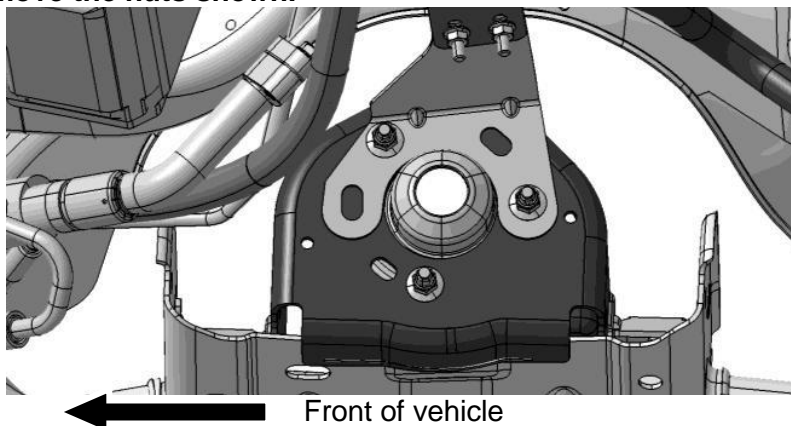

2. Place the Lower Degas Bottle Mounting bracket (1150- 6B634L) on the top of the strut mounting surface and re-install the two nuts. Torque to 40 Nm.



ROUSH[®]
P E R F O R M A N C E

PREMIUM FUEL REQUIRED – NOT E85 COMPATIBLE

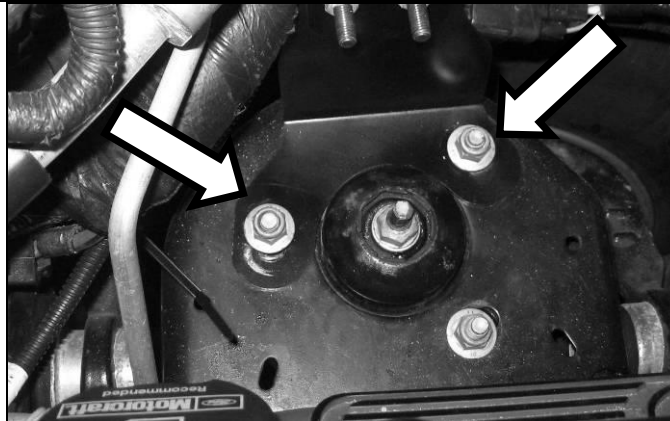

3. Position the Upper Degas Bottle Mounting bracket (1111-6B634U) over the two studs on the Lower Degas Bracket previously installed. Install two (2) M8 nuts (W520413) found in Hardware Kit E, onto the studs and torque to 25Nm.

Note: 4x2 trucks should position the upper bracket in the lower holes on the bracket. 4x4 trucks should position the upper bracket in the upper holes on the bracket.

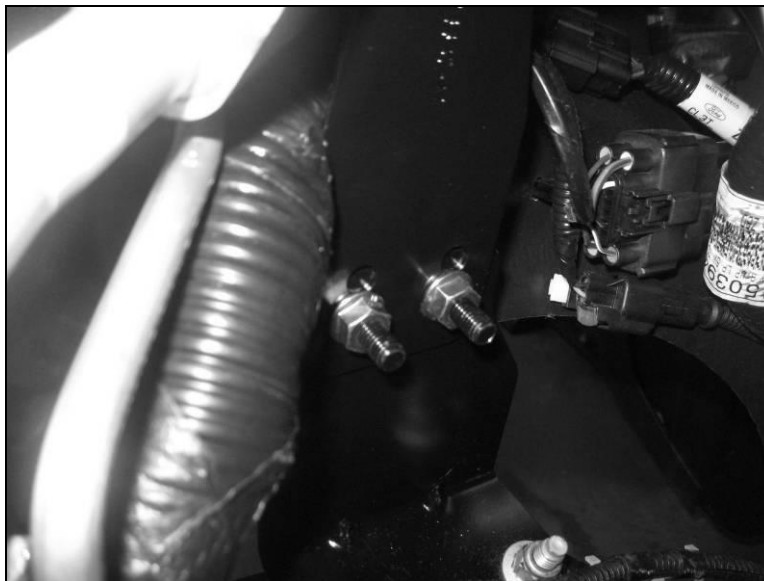

4. Remove the bolt securing the A/C line to the inner fender.



ROUSH®
P E R F O R M A N C E

PREMIUM FUEL REQUIRED – NOT E85 COMPATIBLE

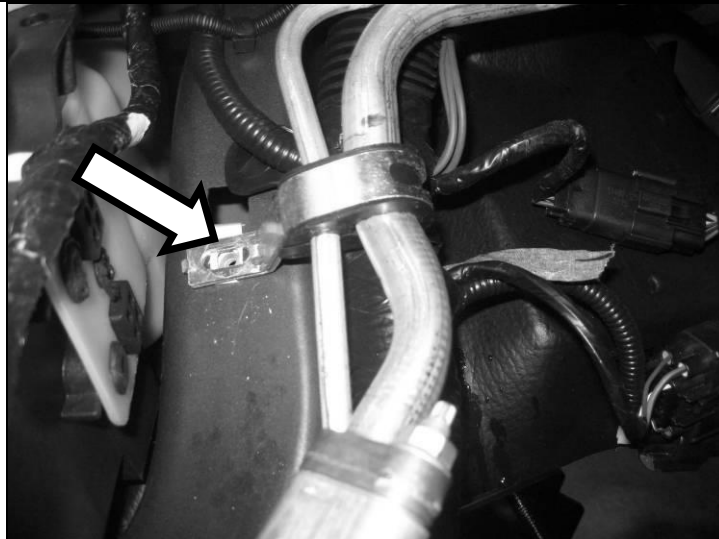

5. Place the Fender to Degas Bottle mounting bracket (1111-6B633) into position as shown and re-install the bolt that retains the A/C line clamp. Torque to 10 Nm.

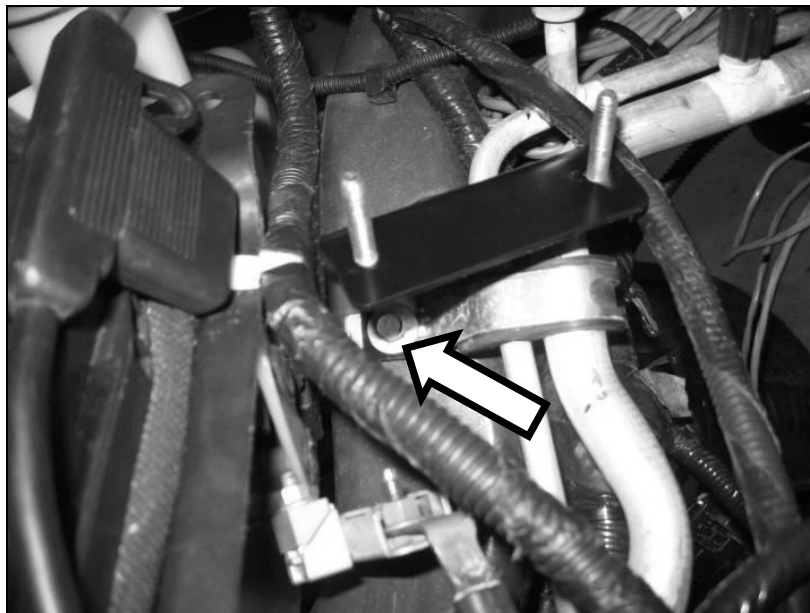

6. Install the Degas Bottle (R07070007) over the two studs on the Fender Mounting Bracket. Install two (2) M6 nuts (W520412) found in Hardware Kit E, over the studs and torque to 10Nm.



ROUSH[®]
P E R F O R M A N C E

PREMIUM FUEL REQUIRED – NOT E85 COMPATIBLE

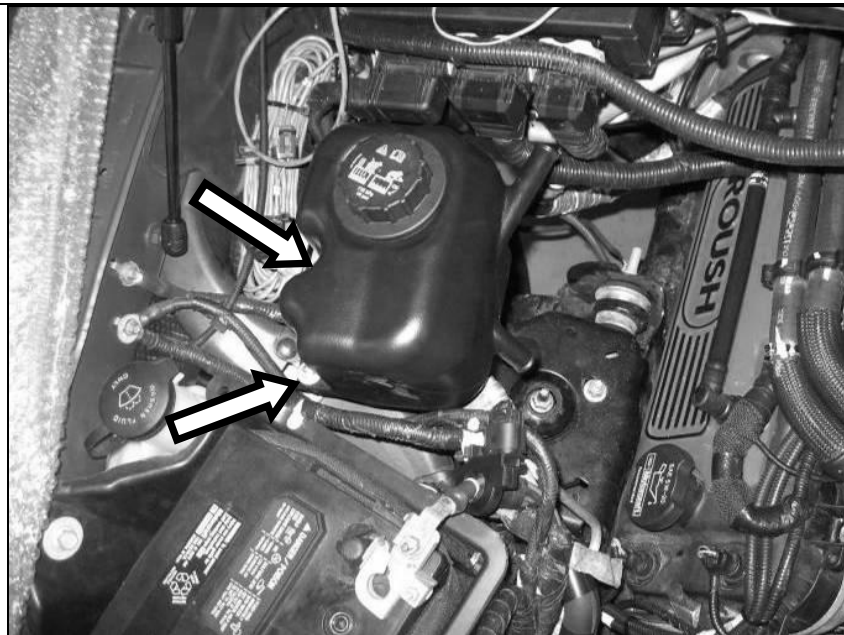

7. Insert one (1) M6x1.0x8 Socket Head Cap Screw (R18020010) found in Hardware Kit E into the mounting hole on the bottom side of the degas bottle, to retain the degas bottle to the strut mounted bracket.



ROUSH[®]
P E R F O R M A N C E

PREMIUM FUEL REQUIRED – NOT E85 COMPATIBLE

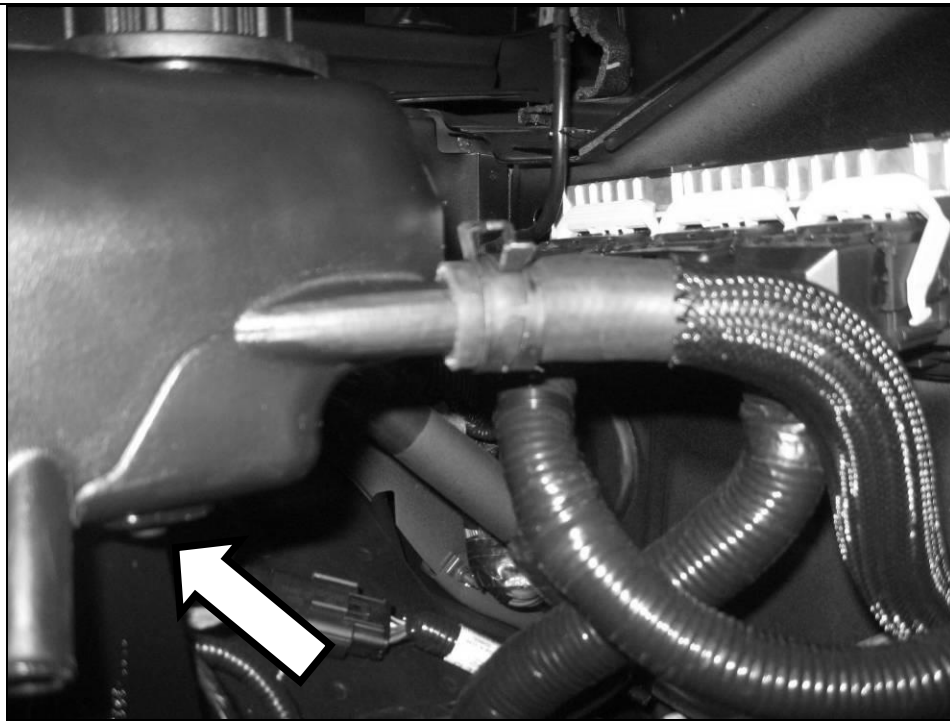



ROUSH[®]
P E R F O R M A N C E

PREMIUM FUEL REQUIRED – NOT E85 COMPATIBLE

Intercooler Radiator Assembly Mounting

1. Install the Upper LH LTR Mounting Bracket (1111-8K242) into the vehicle by removing the bolt underneath the bumper cover to the side of the hood release (LH side of vehicle). Re-install the bolt and position the bracket as shown. Torque bolt to 25 Nm.

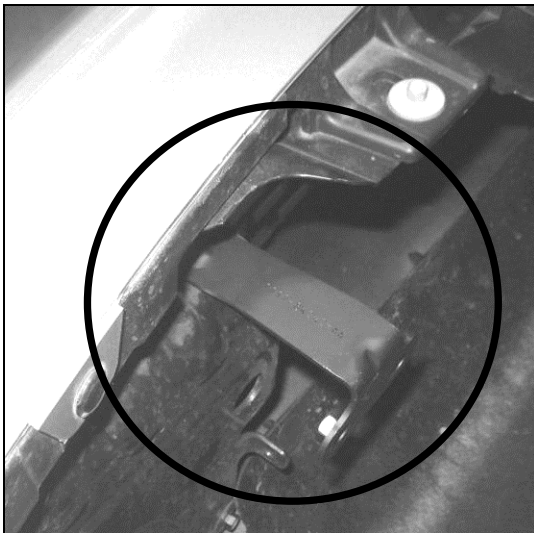

2. Install the Upper RH LTR Mounting Bracket (1111-8K243) into the vehicle by removing the bolt underneath the bumper cover to the side of the hood release (RH side of vehicle). Position the bolt as shown and re-install the bolt. Torque bolt to 25 Nm.

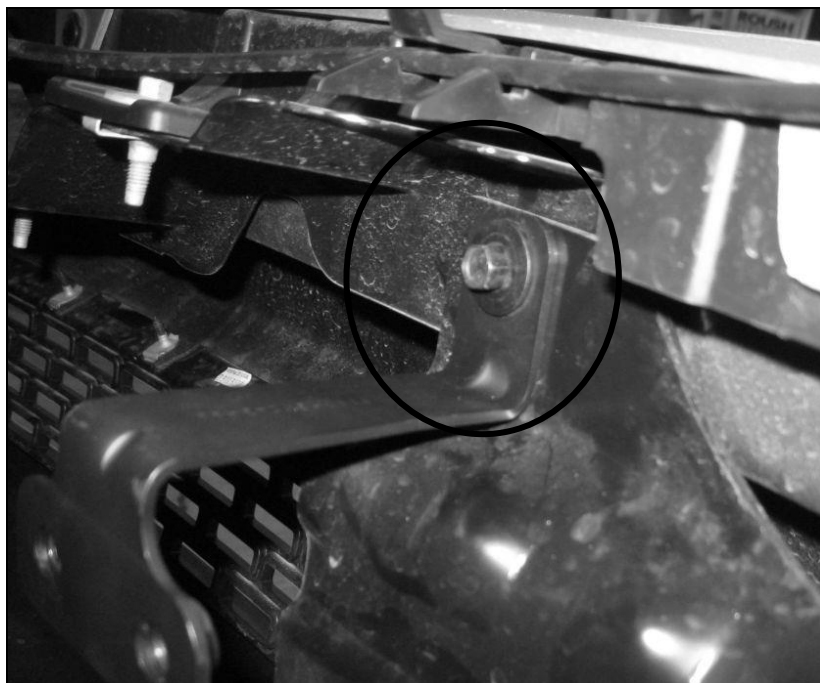



ROUSH[®]
P E R F O R M A N C E

PREMIUM FUEL REQUIRED – NOT E85 COMPATIBLE

3. With the two upper LTR mounting brackets installed it will look like this.

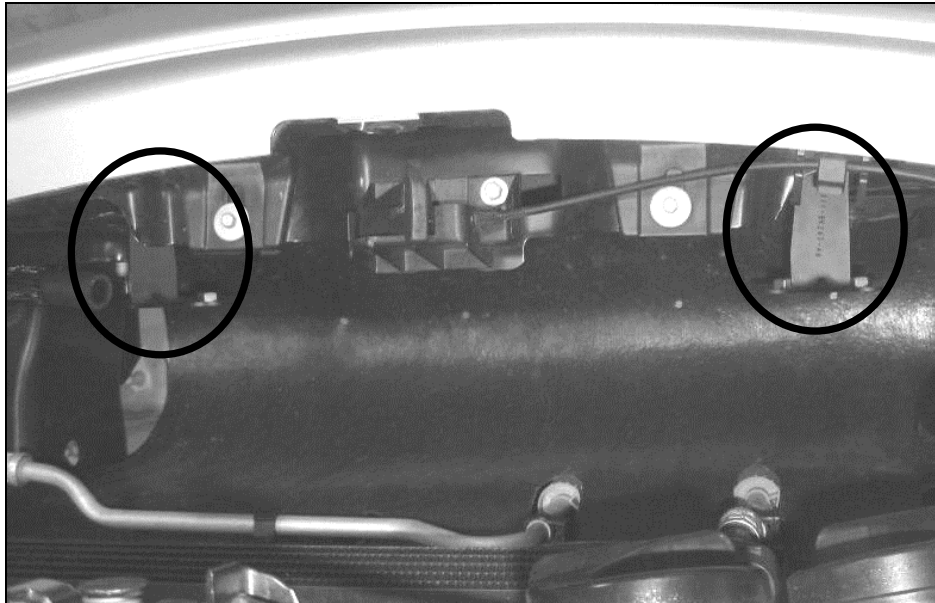

4. Remove the bolt that will retain the Lower LTR Mounting bracket on the passenger side. This is located directly below the Upper LTR Mounting bracket that was installed in the previous step. The air deflection shield may need to be moved aside for proper fitment. This bolt will be re-used.

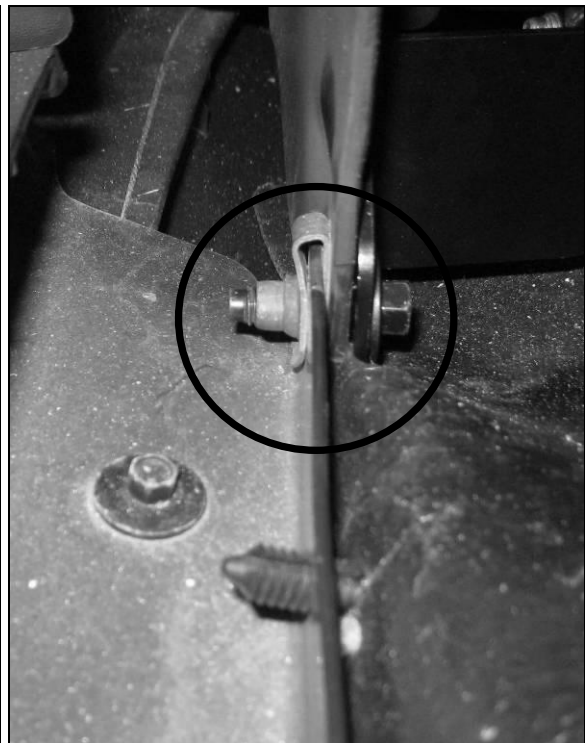



ROUSH[®]
P E R F O R M A N C E

PREMIUM FUEL REQUIRED – NOT E85 COMPATIBLE

5. Using a trim tool, remove the plastic push pin retainers that are holding the air deflector shields in place at the front corner of the frame on both sides.

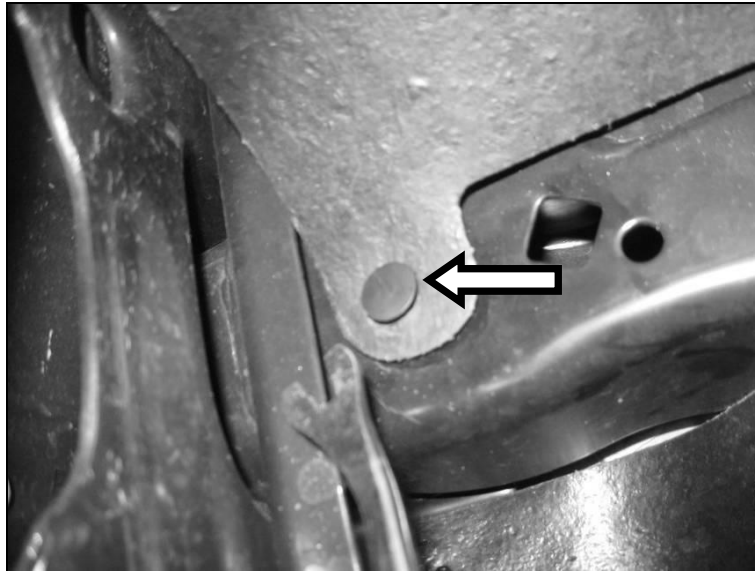

6. With the lower bolt on the passenger side removed, place the LTR Cross brace and pump assembly into position in the vehicle with the pump on the passenger side facing towards the radiator. Re-install the take out bolt (from step 4) into the Lower LTR Mounting bracket. Torque to 25 Nm.

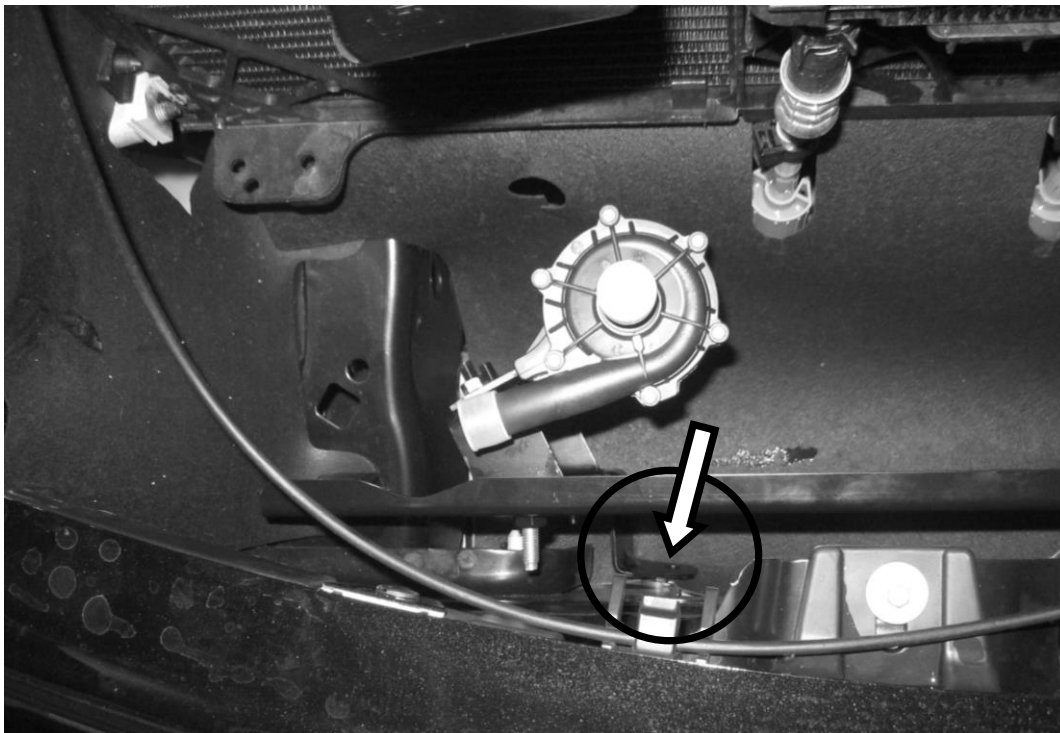



ROUSH[®]
P E R F O R M A N C E

PREMIUM FUEL REQUIRED – NOT E85 COMPATIBLE

7. Position the LTR cross brace over top of the two push pin holes (from step 5) and install the two (2) self threading screws (N802455) found in Hardware Kit D, into the LTR Cross brace on the left and right side of the LTR. Torque to 25 Nm.

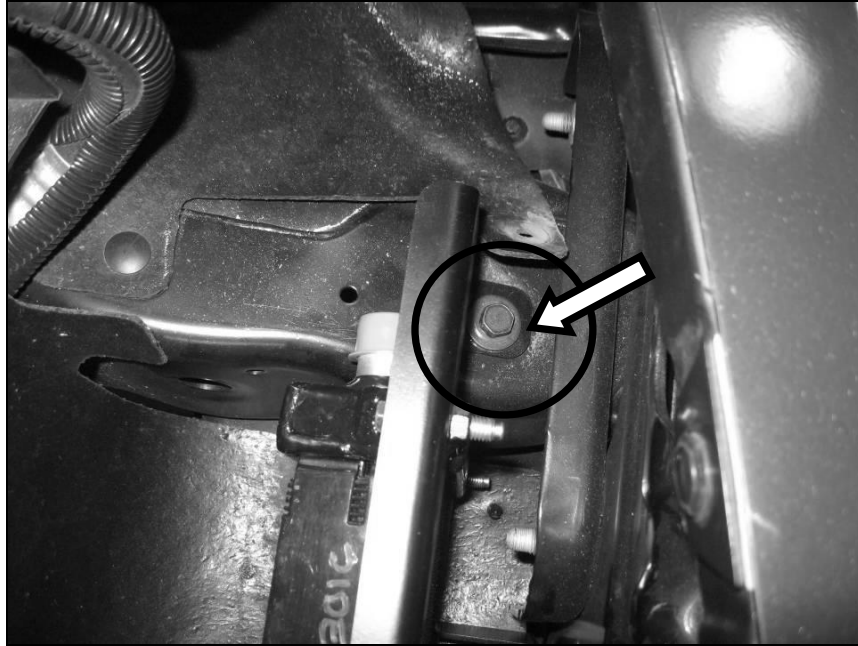

8. Position the lower LTR mounting brackets in behind the LTR Cross Brace such that the lower mounting brackets align with the upper mounting brackets (from step 3). [Pictures shown are removed from vehicle to show clarity.] Install four (4) M8 x 25 (N808920) bolts found in Hardware Kit F (11SC-TVSHKF). Torque to 25 Nm.

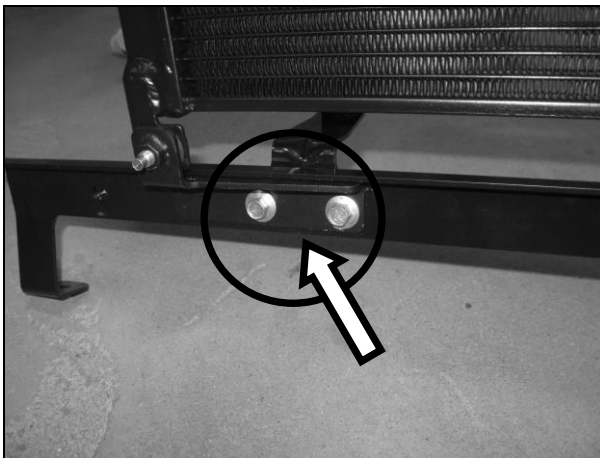



ROUSH[®]
P E R F O R M A N C E

PREMIUM FUEL REQUIRED – NOT E85 COMPATIBLE

9. Remove the horn mounting bracket bolt and position the upper mounting bracket in line with the horn mounting bracket. Re-install the bolt and torque to 25 Nm.

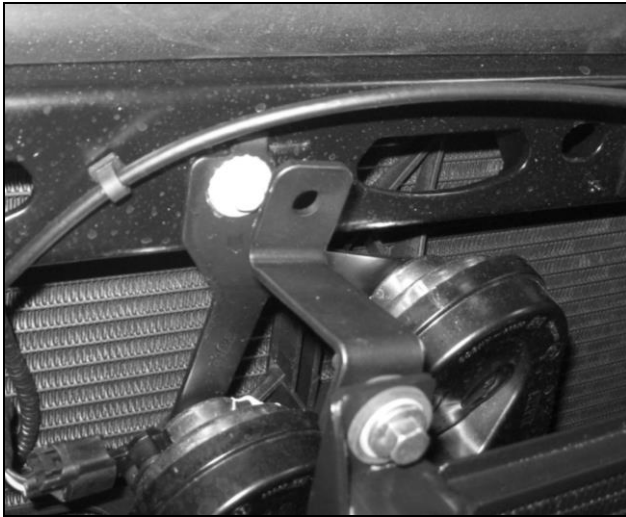

10. Position the top mounting bracket on the drivers side against the radiator core support. Mark the hole position and drill an 1/8" pilot hole through the core support. Enlarge the hole by drilling a 1/4" hole. Position the bracket over the hole and install one (1) self tapping M8x27 bolt, found in Hardware Kit F (11SC-TVSHKF). Torque to 25 Nm. Route the hood release cable around the head of the bolt.

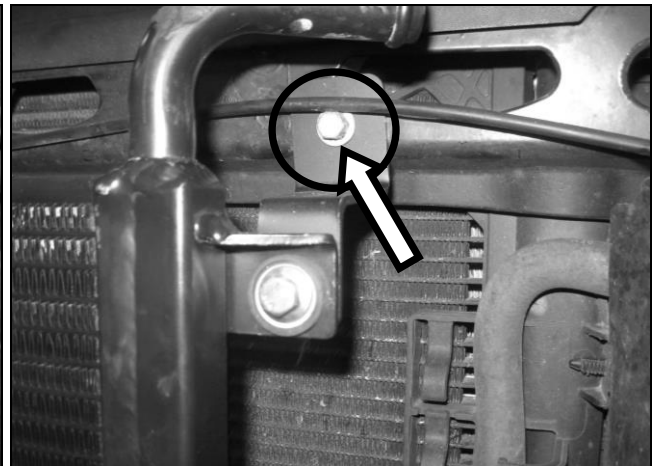
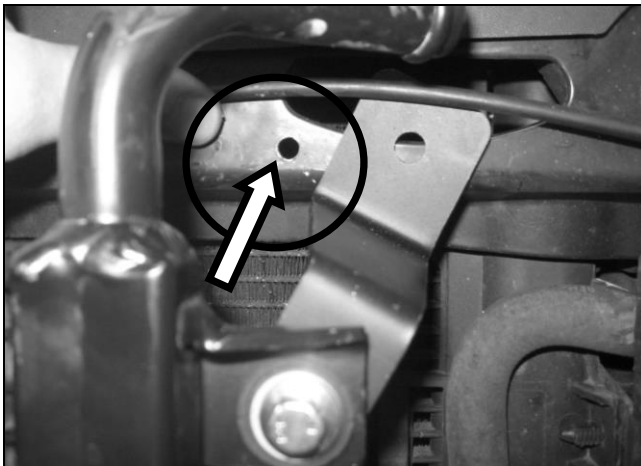



ROUSH[®]
P E R F O R M A N C E

PREMIUM FUEL REQUIRED – NOT E85 COMPATIBLE

Intercooler Hose Circuit

1. With the air deflection shield on the passenger side pulled forward, route the Intercooler Pump Inlet Hose (1111-8D029) from the degas bottle outlet port (bottom port) to the open port of the I/C pump by routing the hose along the A/C line and along the frame rail. Route the hose through the opening between the frame rail & the radiator support.



2. Fold the air deflection shield back into the installed position. Using a knife or scissors, enlarge the hole in the air deflection shield where there is already a hole for the A/C line connection. Route the hose and the I/C pump wiring harness connection through this hole. Secure the harness to one of the holes on the radiator using a zip tie.

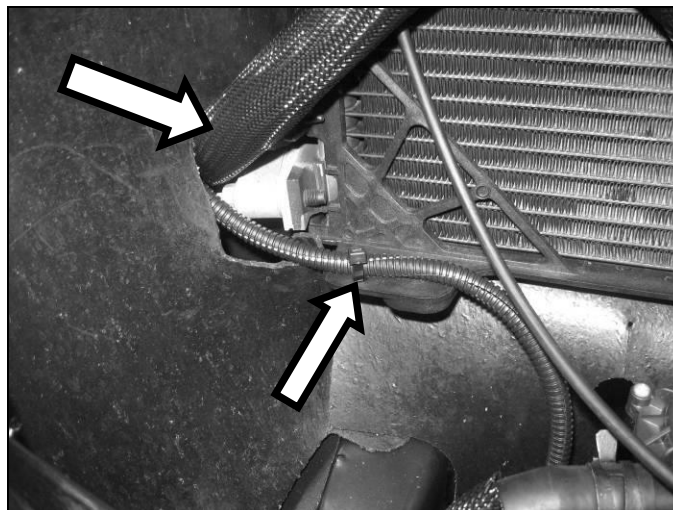



ROUSH[®]
P E R F O R M A N C E

PREMIUM FUEL REQUIRED – NOT E85 COMPATIBLE

3. Secure one end of the hose to the bottom of the degas bottle and the opposite end to the inlet on the pump using one (1) $\frac{3}{4}$ " constant tension clamp (CT19x12-BO) at each end. These can be found in Hardware Kit D (11SC-TVSHKD). Connect the I/C pump harness to the pump.

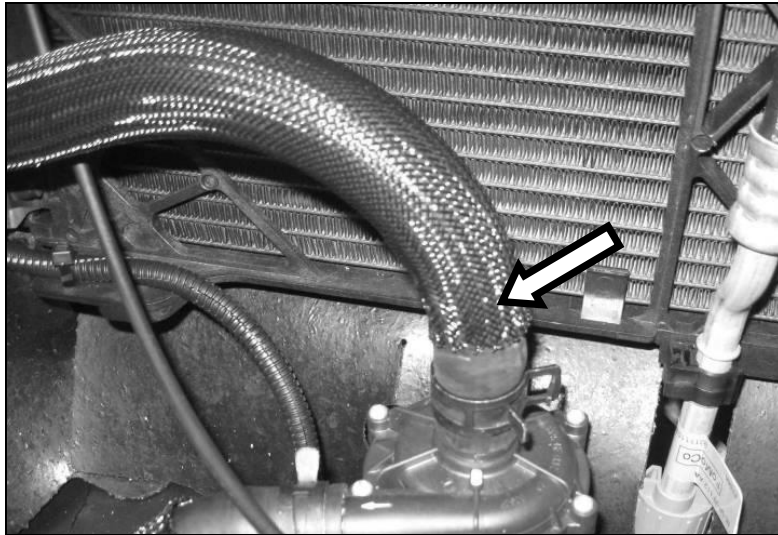

4. Install one (1) $\frac{3}{4}$ " constant tension clamp (CT19x12-BO) onto either end of the I/C Pump to LTR hose (1113-FFLTR8K236). Install the hose onto the pump outlet and onto the LTR inlet and position the clamps to secure the hose.

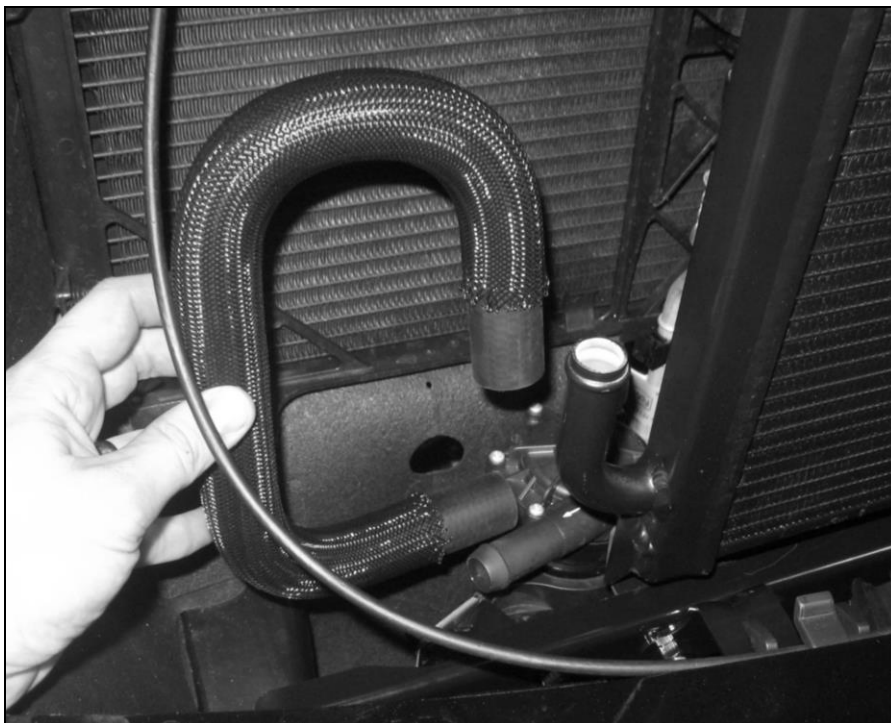



ROUSH[®]
P E R F O R M A N C E

PREMIUM FUEL REQUIRED – NOT E85 COMPATIBLE

5. Install one (1) $\frac{3}{4}$ " constant tension clamp (CT19x12-BO) over both ends of the 1111-8K236 hose. These can be found in Hardware Kit D (11SC-TVSHKD). Connect the short end of the hose to the outlet port of the LTR. Insert the $\frac{3}{4}$ " x $\frac{3}{4}$ " hose connector into the long side of the 1111-8K236 hose and make sure the clamps are in the proper position.

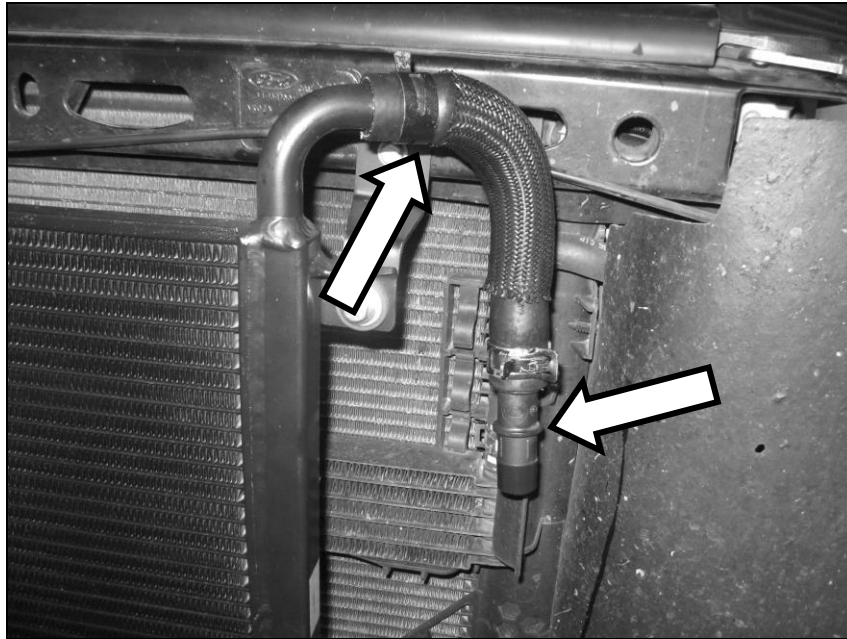

6. Route the LTR Outlet Hose (1111-8D030) through the opening between the frame and radiator on the lower corner of the radiator. Connect the hose to the hose connector and secure using one (1) $\frac{3}{4}$ " constant tension clamp (CT19x12-BO).

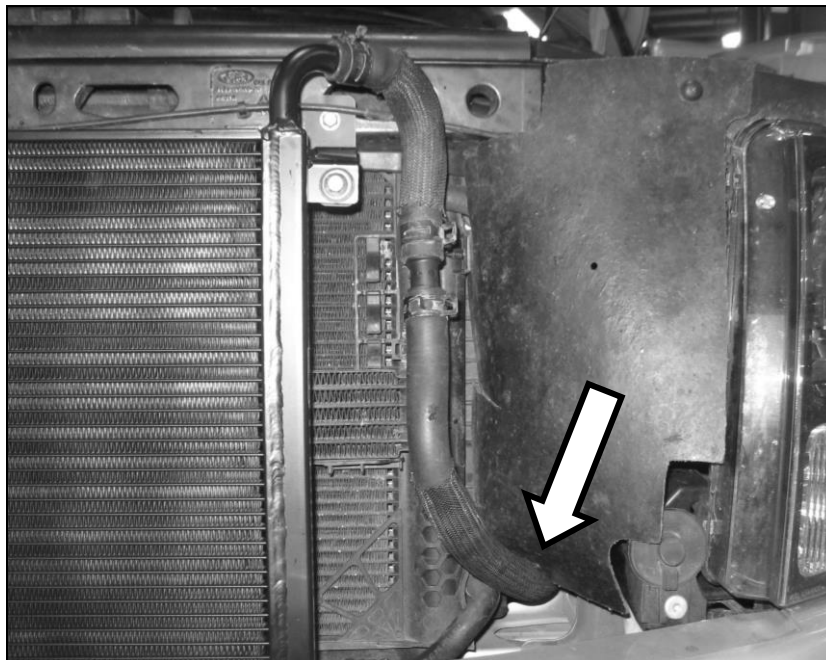



ROUSH[®]
P E R F O R M A N C E

PREMIUM FUEL REQUIRED – NOT E85 COMPATIBLE

7. Drill two small 1/8" holes through the plastic retainer holding the transmission oil cooler into position. Install the 3" length of hose convolute around the hose in this area and retain the hose to the bracket using the provided zip ties. These can be found in Hardware Kit D.

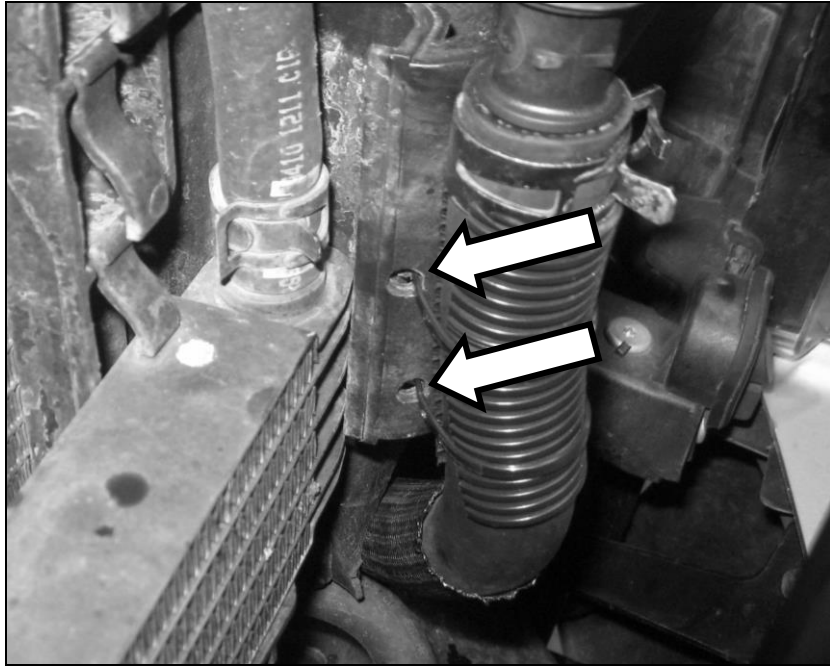

8. The finished hose routing should look like this.

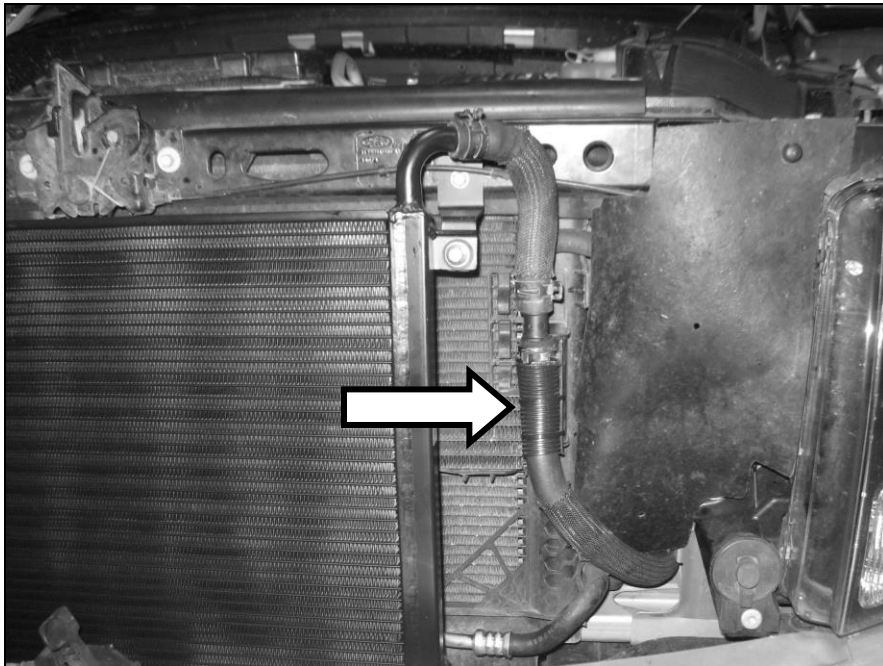



ROUSH[®]
P E R F O R M A N C E

PREMIUM FUEL REQUIRED – NOT E85 COMPATIBLE

9. Install the Degas Bottle to CAC hose (1111-8D031) by connecting it to the top port on the degas bottle (facing the cowl) and routing it around the rear of the engine. Secure the hose to the inlet of the degas bottle using (1) $\frac{3}{4}$ " constant tension clamp (CT19x12-BO). This can be found in Hardware Kit D (11SC-TVSHKD). Retain the hose along the main engine harness across the rear of the engine using zip ties. Route the opposite end of the hose to the front corner of the driver's side cam cover.

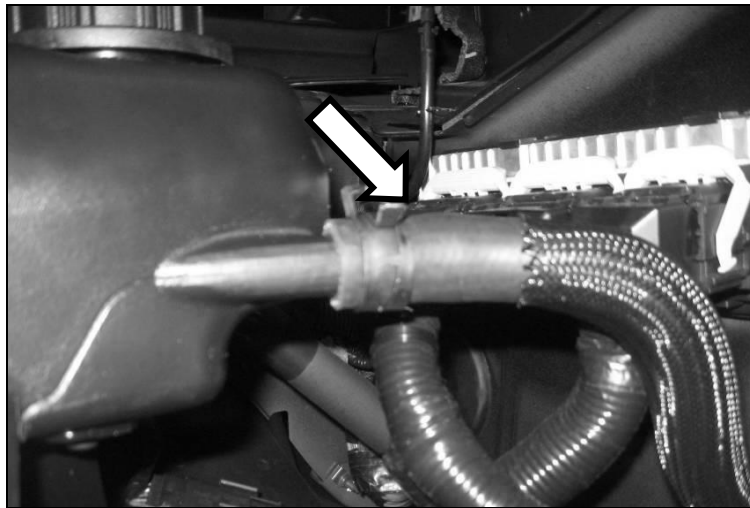

Note: Route all intercooler hoses very carefully. It is critical for intercooler performance that these hoses are not kinked once installed into the vehicle.



ROUSH[®]
P E R F O R M A N C E

PREMIUM FUEL REQUIRED – NOT E85 COMPATIBLE

Intake Manifold and Supercharger Installation

1. Remove the tape from the cylinder heads and clean the cylinder head to intake manifold mating surfaces.
2. Install the intake manifold using six (6) M6 x 1.0 x 40 mm bolts (R18020004) found in Hardware Kit B (1150-TVSHKB). Install these fasteners in the positions shown and tighten the sequence in two stages. Stage 1; torque bolts to 10 Nm. Stage 2; tighten bolts an additional 45 degrees. Reinstall the engine wiring harness retention clips at the rear of the intake manifold.

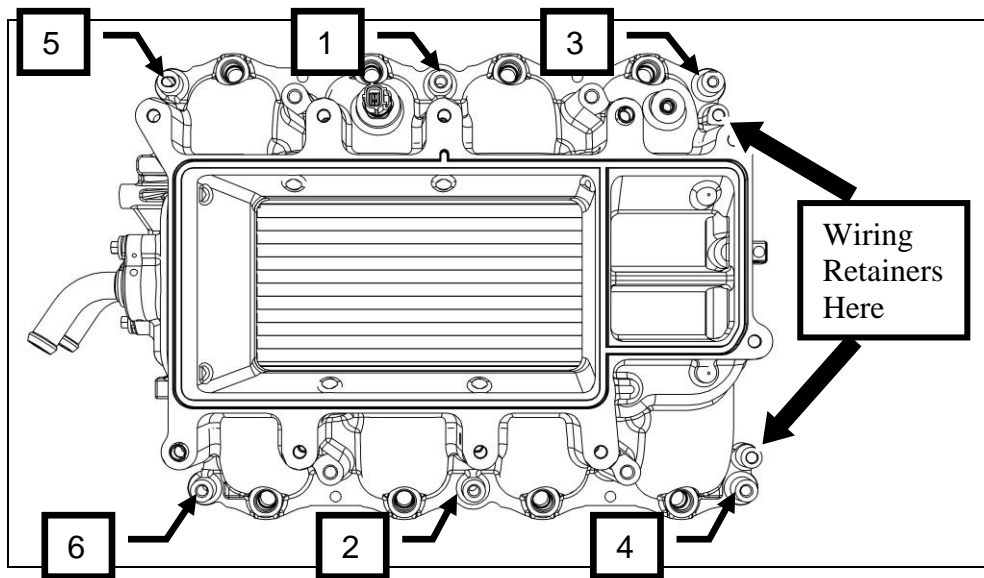

3. Lube the fuel injector o-rings with assembly lube. Install the fuel rail and injectors into the intake manifold using the take off bolts. Be sure each injector is properly seated into the intake manifold. Tighten the bolt pattern in two stages. Stage 1; torque bolts to 10 Nm. Stage 2; tighten bolts an additional 90 degrees.

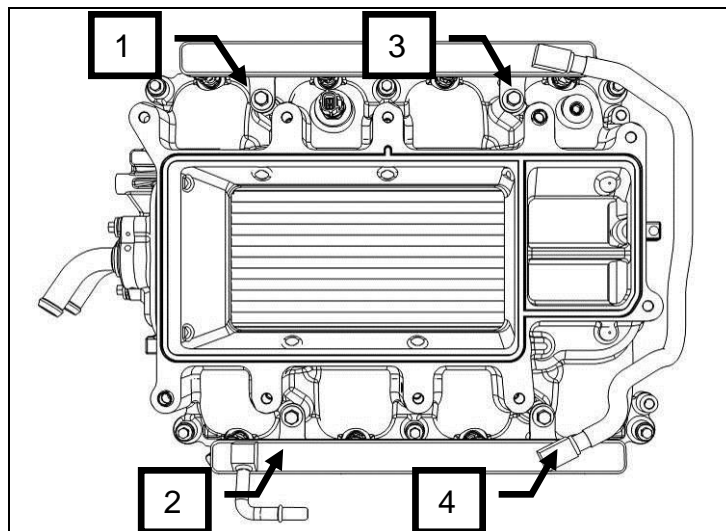



ROUSH[®]
P E R F O R M A N C E

PREMIUM FUEL REQUIRED – NOT E85 COMPATIBLE

4. Connect the eight fuel injector electrical connectors.
5. Remove the supercharger assembly (1311H-6F066) from the protective packaging and place on a workbench or solid flat surface. **Use extreme caution as the bypass actuator housing is fragile.** Remove the protective shipping covers.
6. Install the 80mm supercharger pulley (1313-6K80) onto the hub of the supercharger using the six (6) M6x14 fasteners (N605771) found in Hardware Kit B (1150-TVSHKB). Apply a small amount of blue thread locking compound to the bolts, and torque to 10 Nm.





ROUSH®
P E R F O R M A N C E

PREMIUM FUEL REQUIRED – NOT E85 COMPATIBLE

7. Connect the supercharger bypass reference vacuum line (14" length of hose R18140001) to the bottom fitting on the supercharger bypass actuator. Route this underneath the VMV and fuel line.

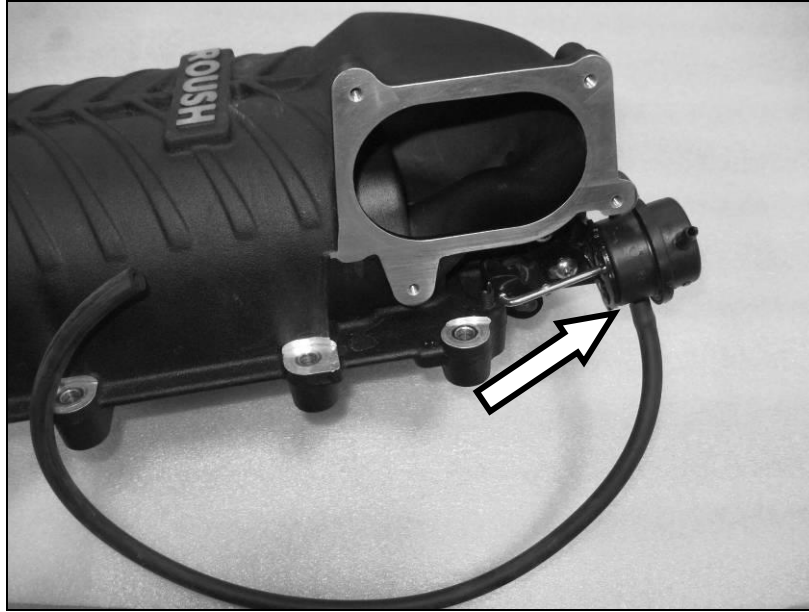

8. Insert one (1) of the M8 x 53 fasteners (N808130) found in Hardware Kit B (1150-TVSHKB) into the mounting hole directly below the supercharger inlet.

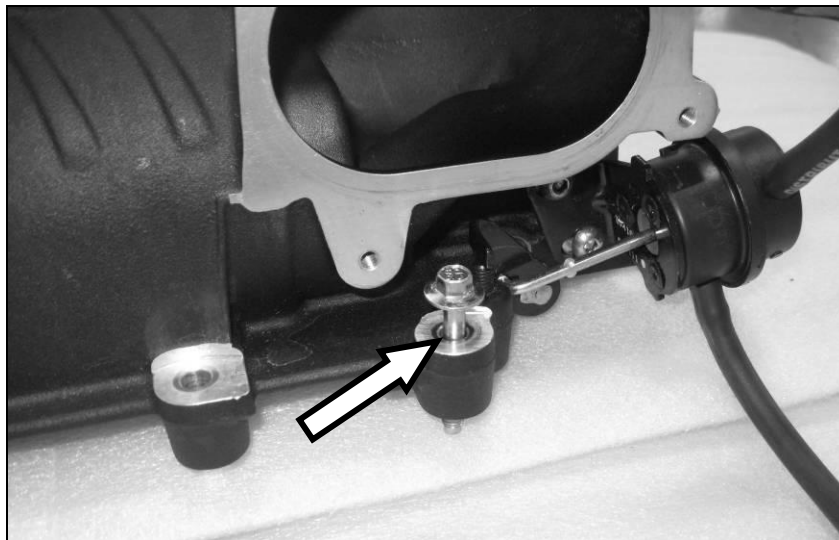



ROUSH[®]
P E R F O R M A N C E

PREMIUM FUEL REQUIRED – NOT E85 COMPATIBLE

9. Install the throttle body spacer to supercharger gasket (R07060152) between the throttle body spacer assembly and the supercharger and mount the spacer using (4) M6 x 32 fasteners (R18020009). These parts can be found in Hardware Kit B (1150-TVSHKB). Torque the fasteners to 10 Nm.

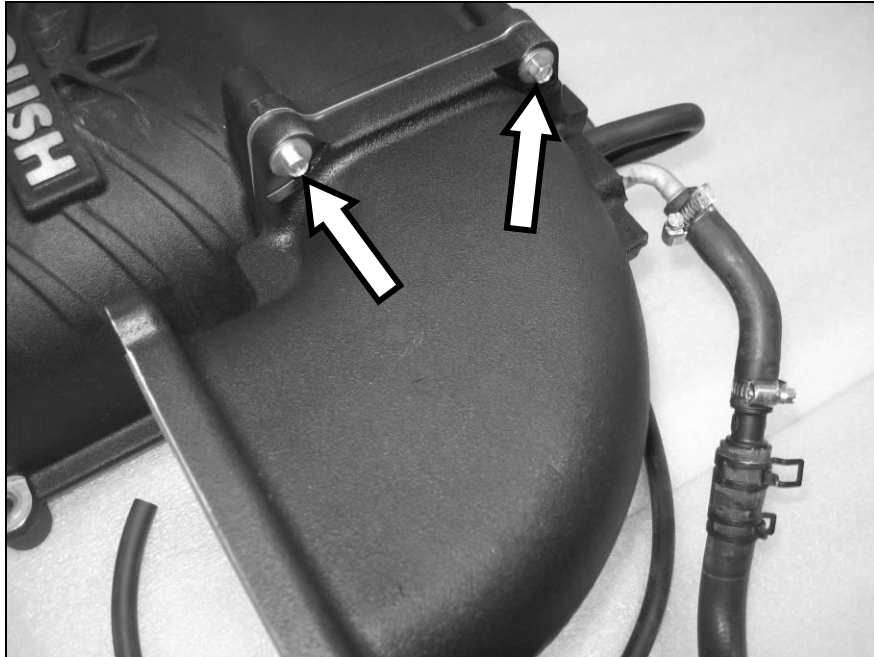

10. Connect the boost bypass hose from the throttle body spacer to the top port of the supercharger bypass actuator.

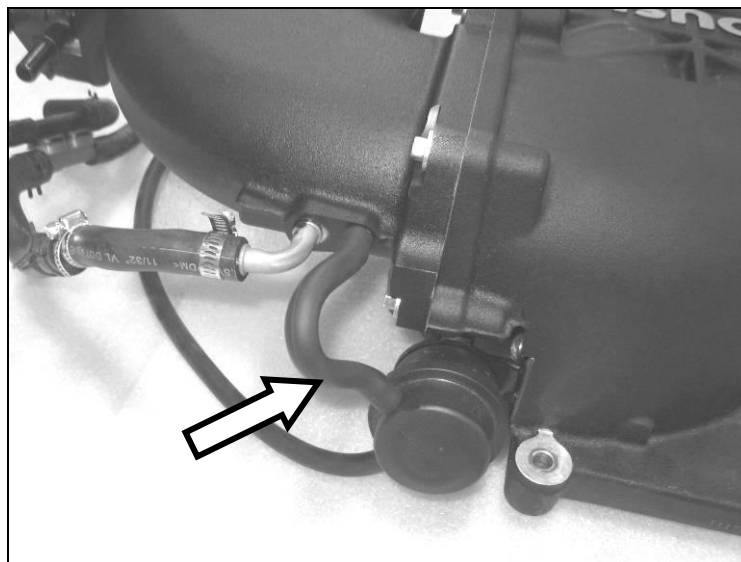



ROUSH[®]
P E R F O R M A N C E

PREMIUM FUEL REQUIRED – NOT E85 COMPATIBLE

11. With the help of an assistant, carefully place the supercharger and throttle spacer on top of the intake manifold, sliding it underneath the cowl into position. Ensure that the supercharger is fully seated on the intake mounting dowels. Note: Make sure the bolt mounted below the throttle body spacers does not catch on anything as you slide the supercharger into position.
12. Install the remaining nine (9) M8 x 53 fasteners (N808130) provided found in Hardware Kit B (1150-TVSHKB) into the mounting holes. Torque fasteners in three steps; 10Nm, 20Nm and 30Nm in the sequence shown. Access bolt hole number 10 by reaching behind the supercharger from the passenger side of the vehicle.

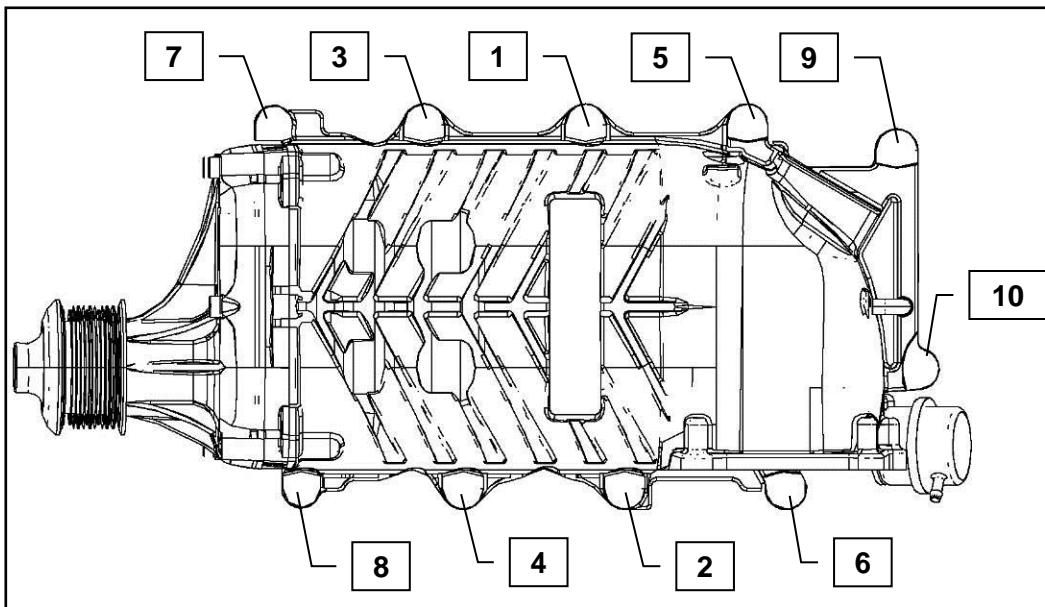



ROUSH[®]
P E R F O R M A N C E

PREMIUM FUEL REQUIRED – NOT E85 COMPATIBLE

13. Connect the short 90° hose to the check valve on the brake booster and secure with the clamp to the check valve. Note: It is recommended that some form of abrasion resistant sleeve or convoluting be installed on the brake aspirator lines to prevent chaffing of components.

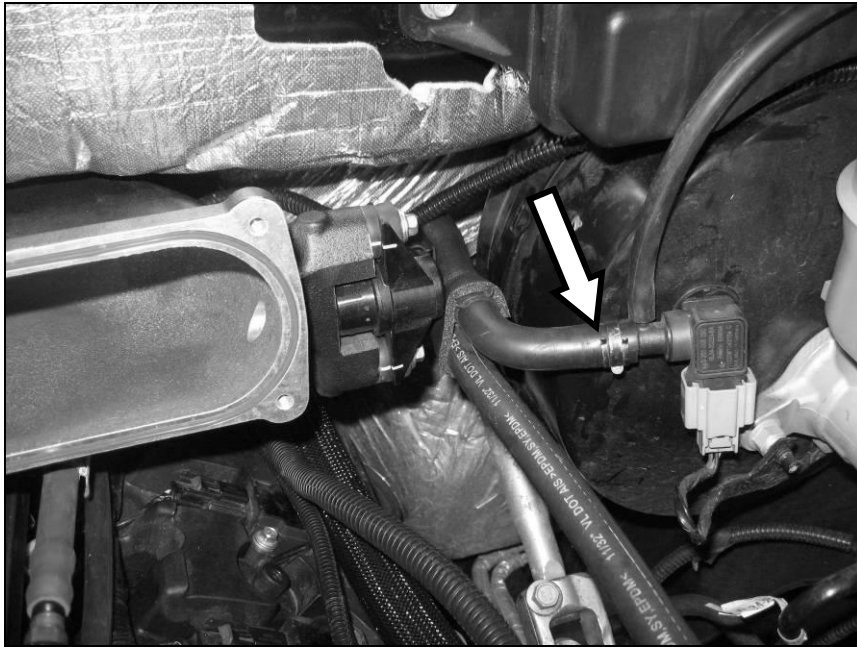

14. Connect the new Evaporative Emission Canister Purge Valve electrical connector.

15. Connect the new Evaporative Emission Canister Purge Valve hose quick connect fitting to the relocated Purge Valve on the Throttle Body Spacer.

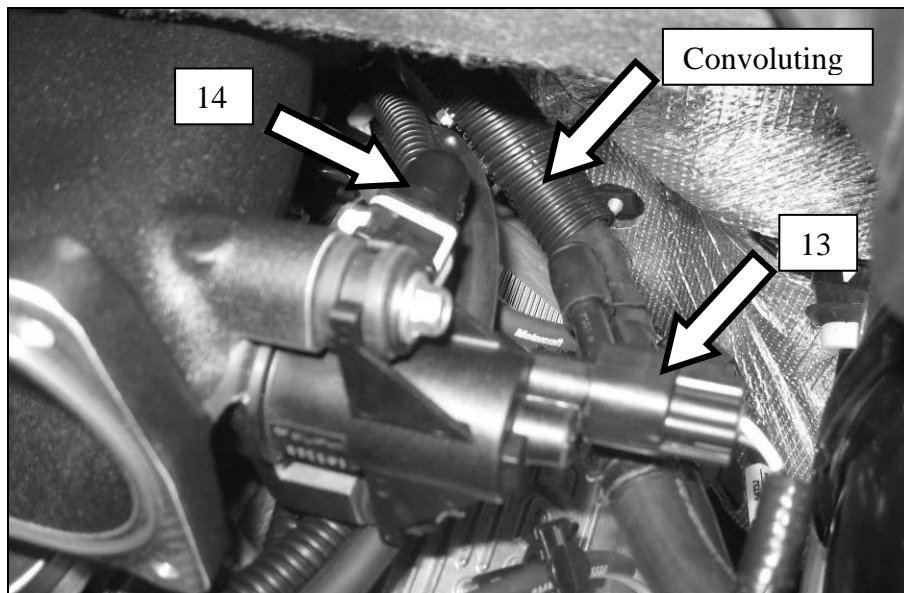



ROUSH[®]
P E R F O R M A N C E

PREMIUM FUEL REQUIRED – NOT E85 COMPATIBLE

16. Connect the fuel inlet line to the fuel rail. Secure the lock into position.

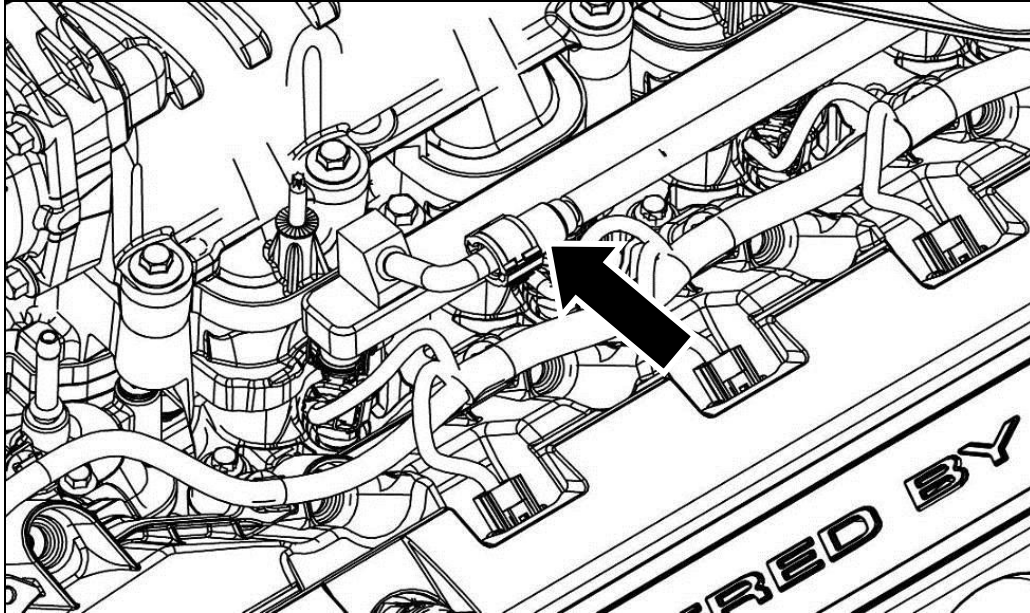

17. Connect the PCV Purge Line (13116K817) to the PCV Valve on the passenger side cam cover and the port on the supercharger.

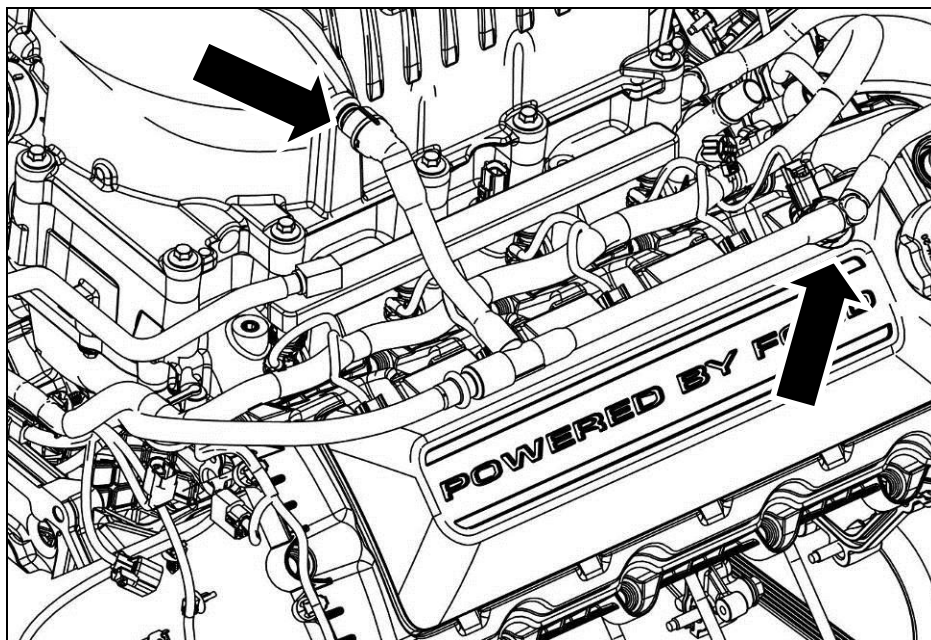



ROUSH[®]
P E R F O R M A N C E

PREMIUM FUEL REQUIRED – NOT E85 COMPATIBLE

18. Install the Throttle Body Gasket (R07060153) in the Throttle Body Spacer. Use (4) M6 x 1.0 x 32.5 mm bolts (R18020009) to secure the Throttle Body Assembly (R07060150) to the Spacer. Torque bolts to 10 Nm. These can be found in Hardware Kit B (1150-TVSHKB).

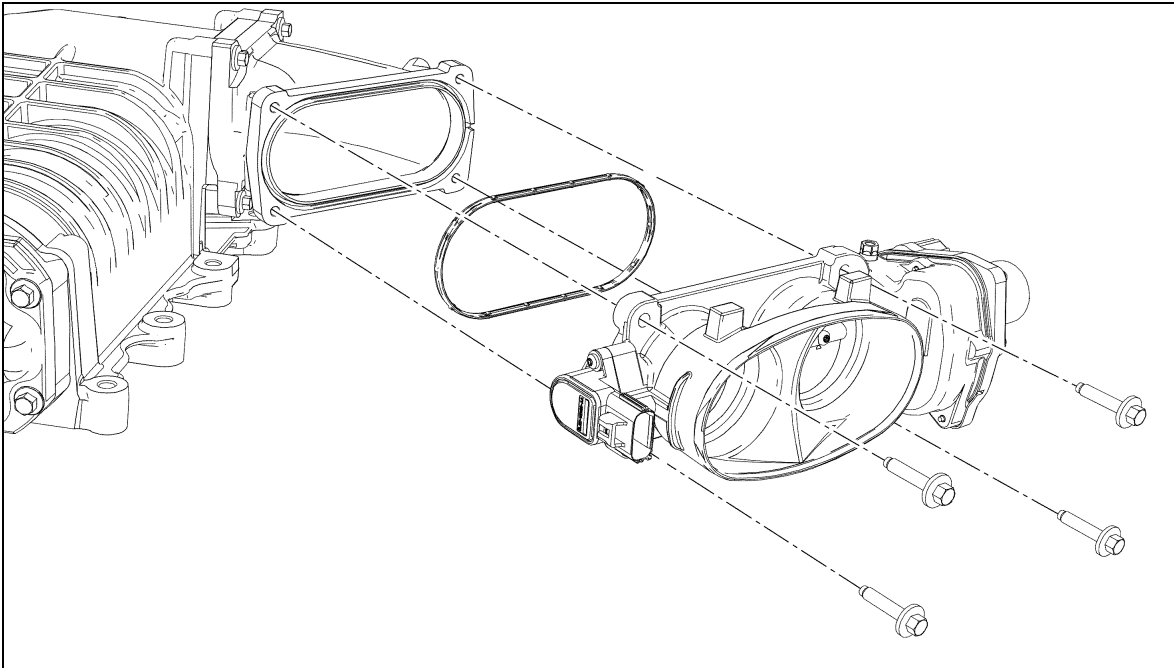

19. Connect the TPS and ETC Throttle Body electrical connectors.

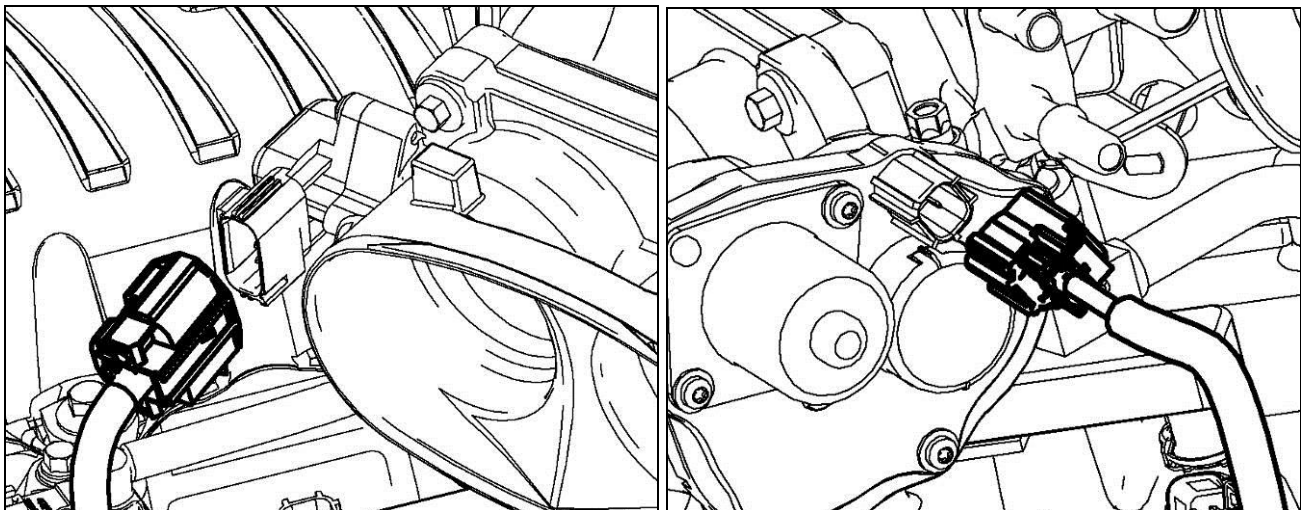



ROUSH[®]
P E R F O R M A N C E

PREMIUM FUEL REQUIRED – NOT E85 COMPATIBLE

FEAD Assembly

NOTE: IF INSTALLING ON 2014+ F-150, INSTALL THE COMPONENTS INCLUDED IN THE OPTIONAL SUPPLEMENTAL FEAD KIT BEFORE PROCEEDING.

1. Remove the (4) bolts and (1) stud from the front cover as shown.

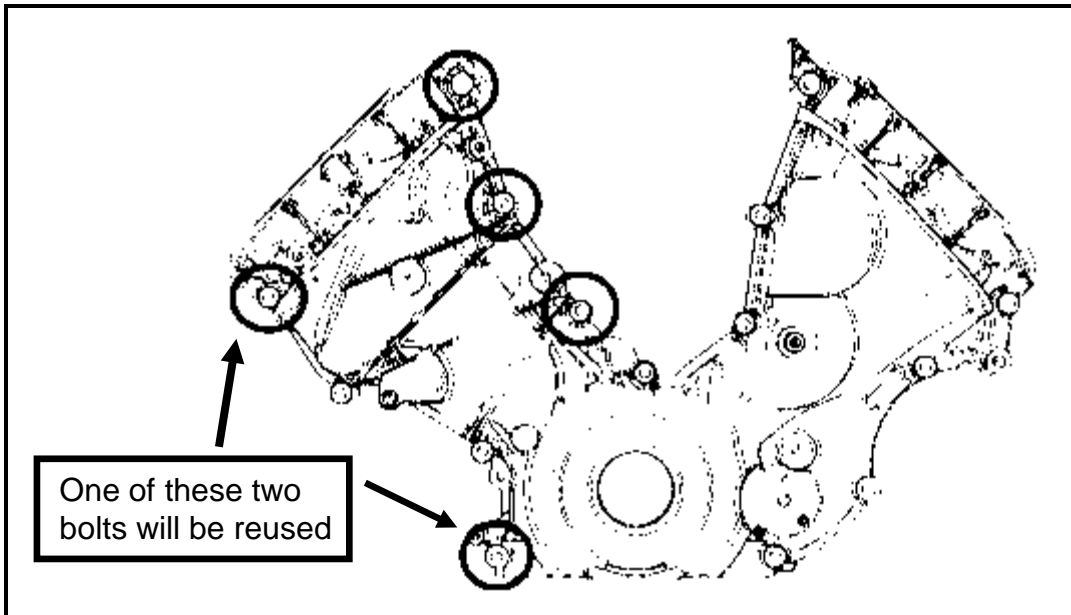

2. Remove and discard the 10mm water pump fastener shown below.

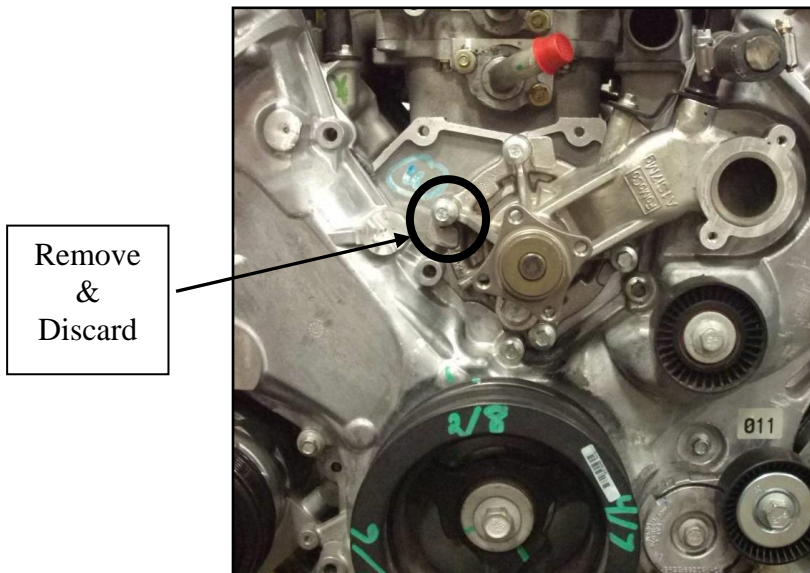



ROUSH[®]
P E R F O R M A N C E

PREMIUM FUEL REQUIRED – NOT E85 COMPATIBLE

3. Install the Upper FEAD Bracket (13148B653U) using one (1) M8x1.25x57 bolt that was removed in the previous step, three (3) M8x1.25x60 bolt (11127083) and two (2) M8x1.25x84 bolts (W704752) from Hardware Kit C (13116066FRTHKC). Torque bolts to 20-30 Nm.

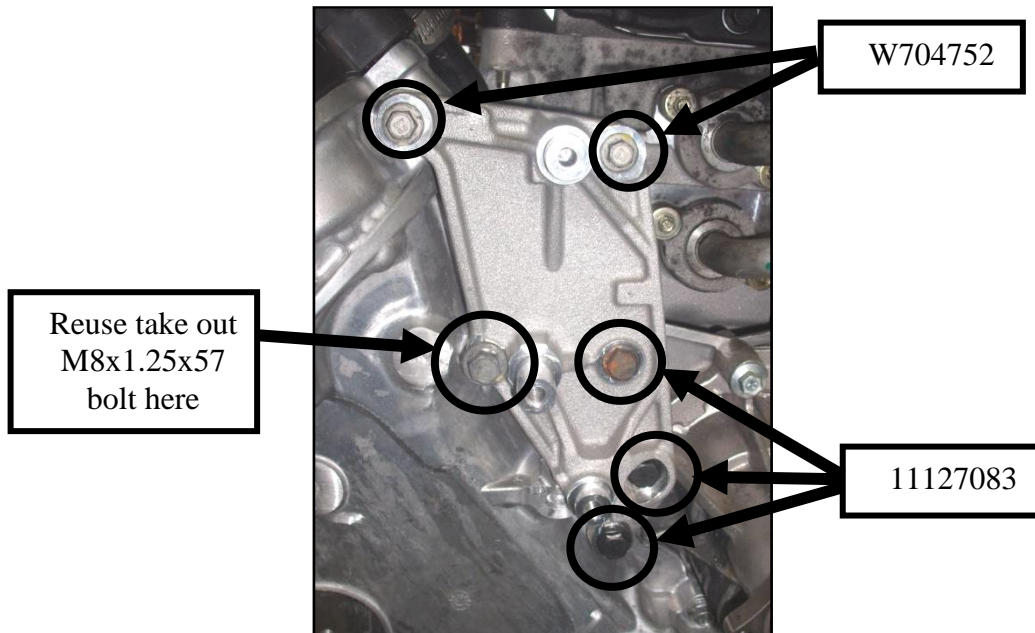

4. Install (2) Idler Pulleys (953045) onto the machined posts of the Upper FEAD Bracket. Secure the pulleys using (2) M8 x 1.25 x 28mm idler bolts (R18020060) found in Hardware Kit C. Torque bolts to 25 Nm.

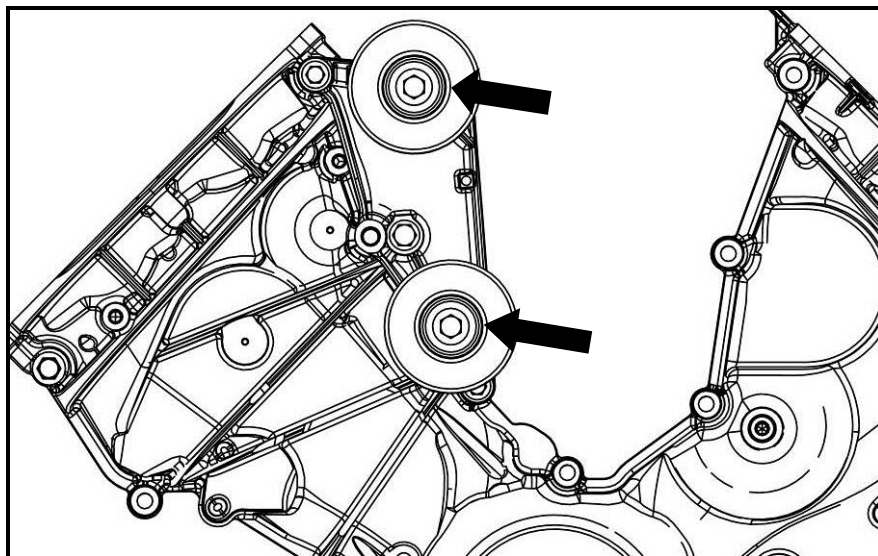



ROUSH[®]
P E R F O R M A N C E

PREMIUM FUEL REQUIRED – NOT E85 COMPATIBLE

5. Loosely install the FEAD Tensioner Bracket Assembly (13118B603) onto the front cover using (2) M8 x 1.25 x 120mm (N811329) bolts found in Hardware Kit C, leaving at least a 10mm gap between the two new FEAD brackets.

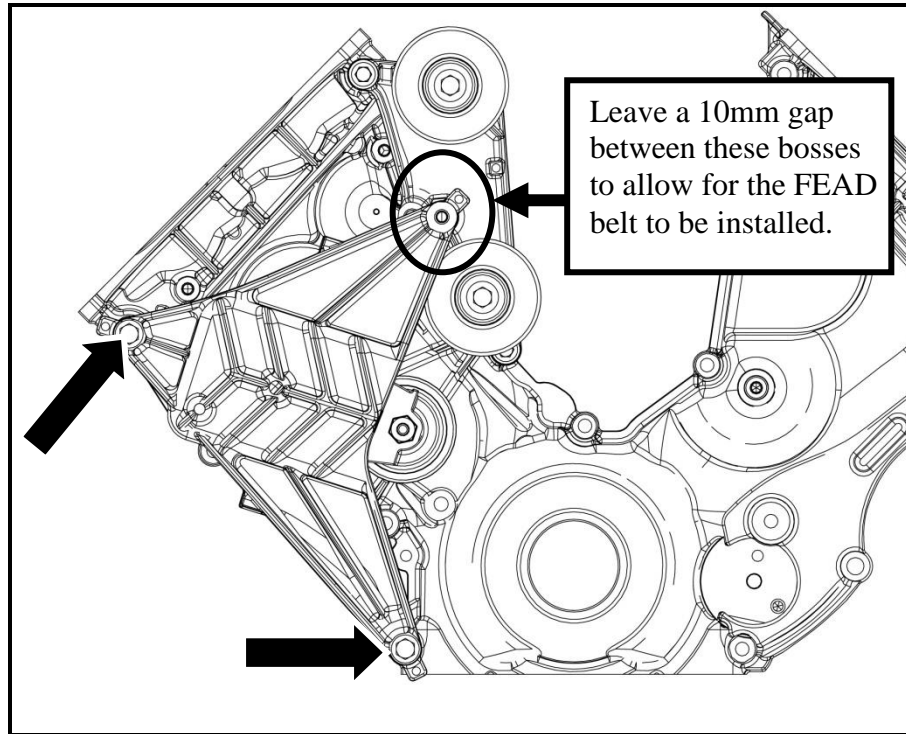



ROUSH[®]
P E R F O R M A N C E

PREMIUM FUEL REQUIRED – NOT E85 COMPATIBLE

6. Route the FEAD belt (6K2085-8620). Do not route the belt onto the supercharger pulley.

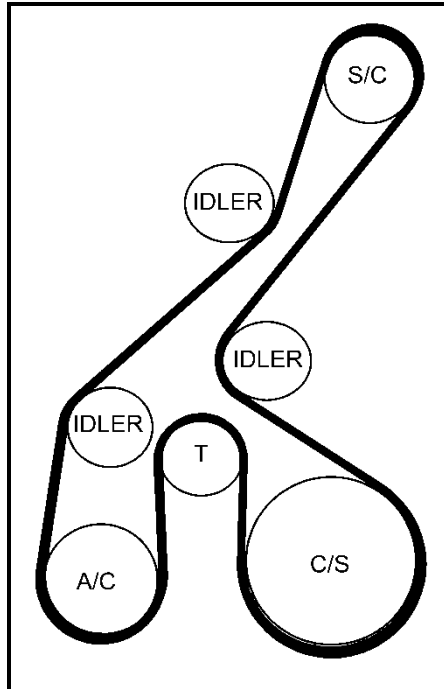

7. Install (1) M8 x 1.25 x 41mm (W705128) bolt found in Hardware Kit C, to fasten the Tensioner Bracket to the Upper FEAD Bracket. Torque all three Tensioner Bracket bolts to 20-30 Nm.

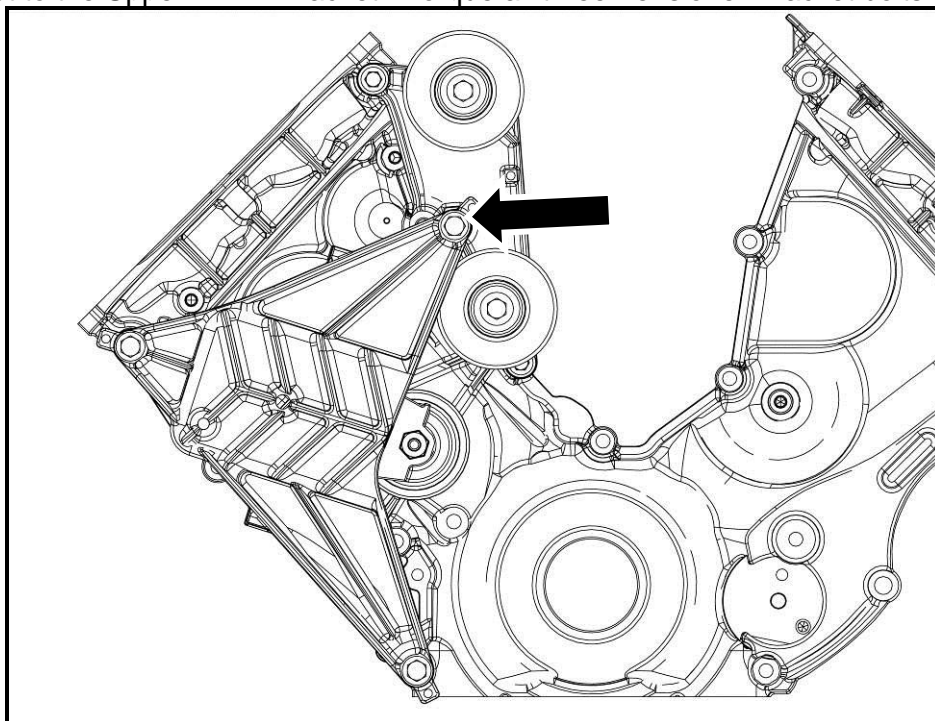



ROUSH[®]
P E R F O R M A N C E

PREMIUM FUEL REQUIRED – NOT E85 COMPATIBLE

- Using a 17mm socket, rotate the new tensioner clockwise to install the belt on to the supercharger pulley. Inspect each pulley to ensure the belt is properly seated.

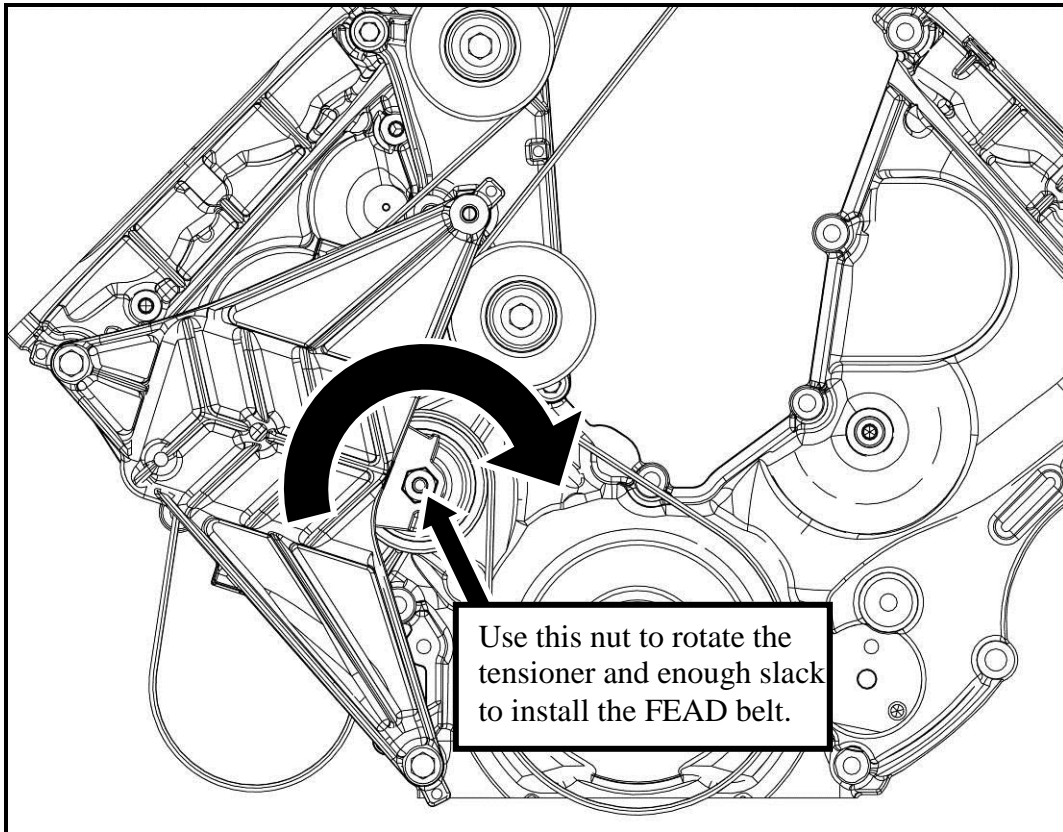

- Re-install the Coolant Pump Pulley using the (4) take off bolts. Torque bolts to 20-30 Nm.

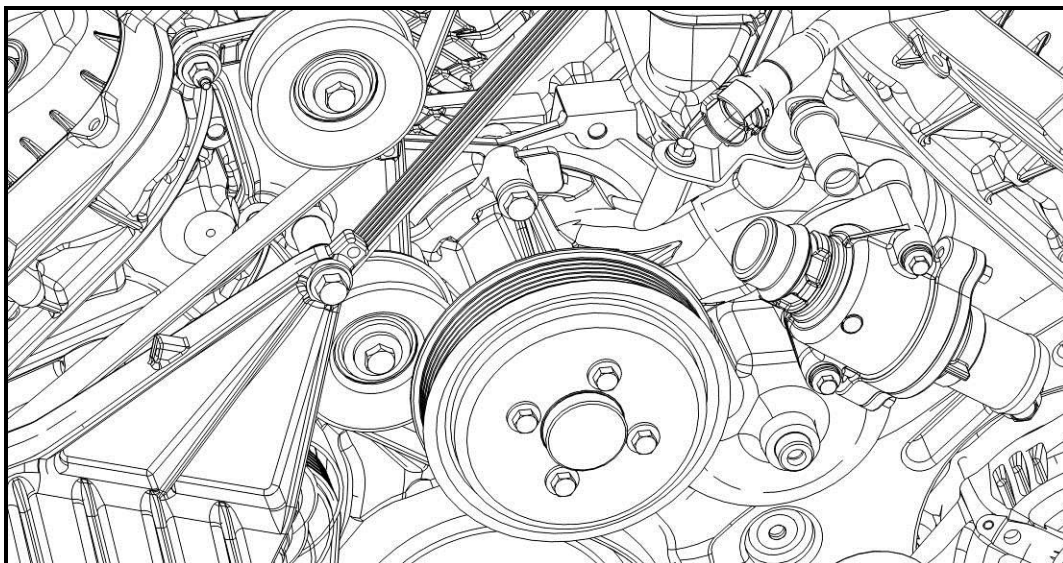



ROUSH[®]
P E R F O R M A N C E

PREMIUM FUEL REQUIRED – NOT E85 COMPATIBLE

10. Re-install the stock FEAD Belt by rotating the tensioner counter-clockwise and routing the belt as per the stock Ford belt routing.

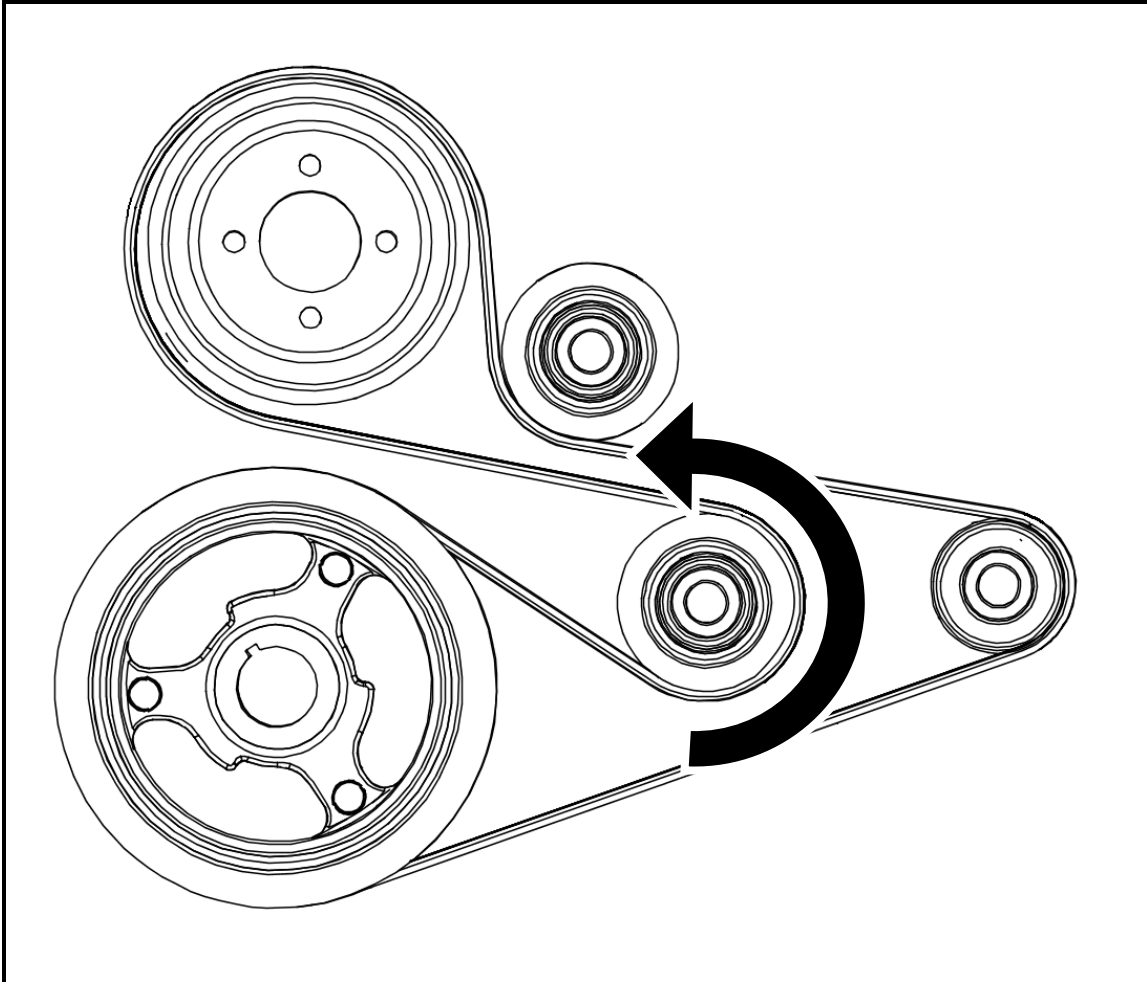



ROUSH[®]
P E R F O R M A N C E

PREMIUM FUEL REQUIRED – NOT E85 COMPATIBLE

Coolant Hoses

1. Connect the Intercooler LTR Outlet hose (1111-8D030) to the lower turret on the intake manifold. Secure the hose using one (1) $\frac{3}{4}$ " constant tension clamp from Hardware Kit D.

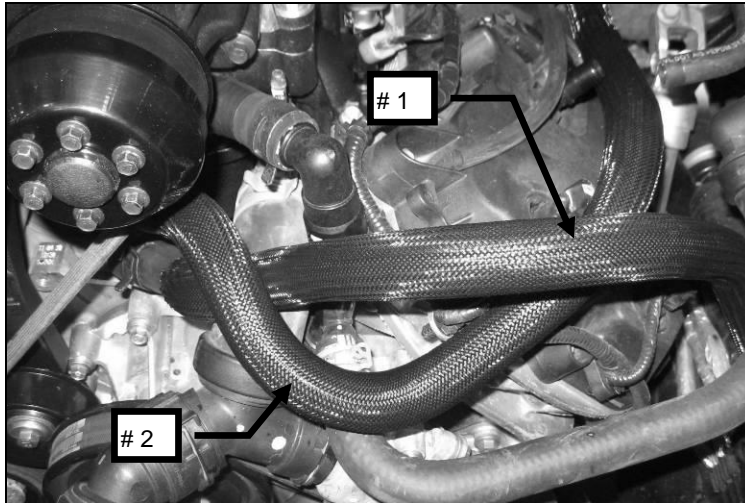

Ensure all of the hoses have been installed to provide maximum clearance to the supercharger belt.

2. Connect the Degas Bottle Inlet Hose (1111-8D031) to the upper intercooler turret on the intake manifold. Secure using one (1) $\frac{3}{4}$ " constant tension clamp from Hardware Kit D. Retain both hoses together using zip ties.
3. Route the new Heater Inlet Hose assembly(1150-18K579) underneath the drive snout of the supercharger and connect the 90° quick connect fitting to the heater return tube.

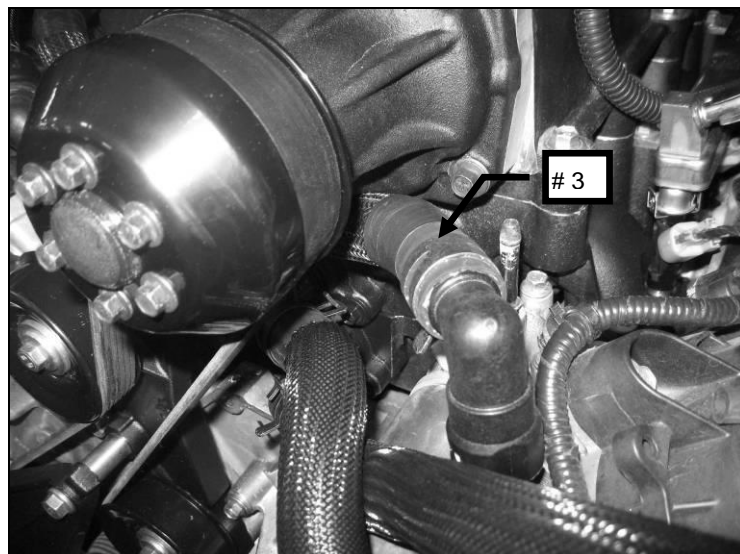



ROUSH[®]
P E R F O R M A N C E

PREMIUM FUEL REQUIRED – NOT E85 COMPATIBLE

4. Remove the turret bolt on the upper passenger side of the engine, and install the P-Clip that was in the heater hose kit. Wrap the clip around the heater inlet hose as shown & re-install the turret bolt. Torque to 10 Nm.

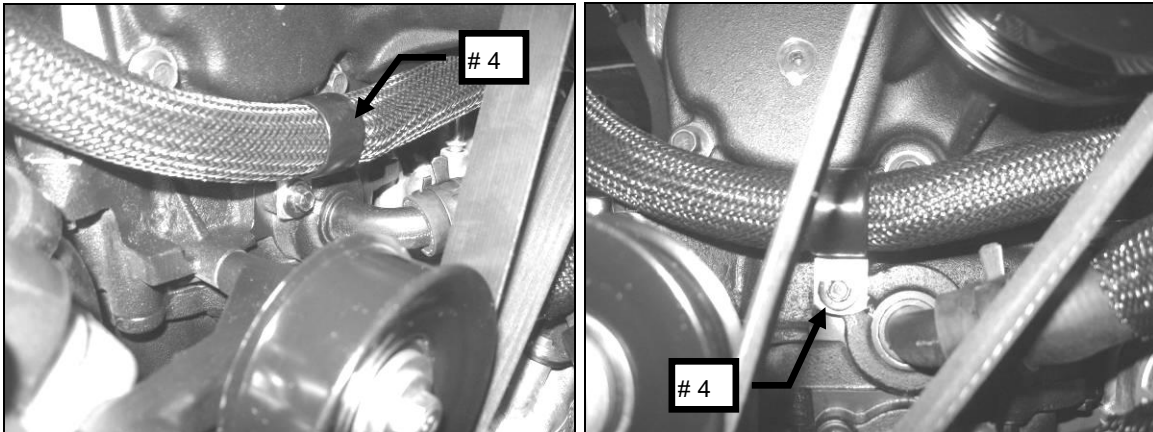

5. Connect the straight quick connect end of the Heater Inlet Hose assembly to the quick connect fitting on the cowl. Route the two heater hoses together and re-connect the plastic hose connector that will hold them together.





ROUSH[®]
P E R F O R M A N C E

PREMIUM FUEL REQUIRED – NOT E85 COMPATIBLE

6. Reinstall the upper radiator hose and connect to both the engine and radiator.



7. Remove 35 mm (1.5 inches) from the factory 3/8" Engine Bottle Degas Hose and reconnect the hose from the engine degas bottle to the fitting on the driver side cylinder head. Secure with the constant tension clamp.

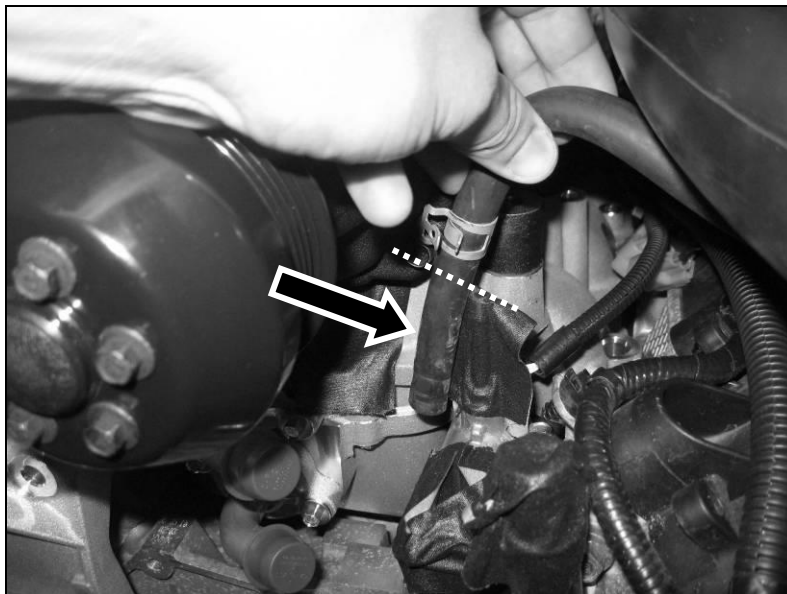



ROUSH[®]
P E R F O R M A N C E

PREMIUM FUEL REQUIRED – NOT E85 COMPATIBLE

Air Induction System

1. Install the new ROUSH open air filter element (997-466) onto the MAF Tube (11SC-12B579) and tighten the clamp.



2. Install the two (2) J-clips (W520823) provided in Hardware Kit A (11SC-TVSHKA) onto the airbox lid as shown.

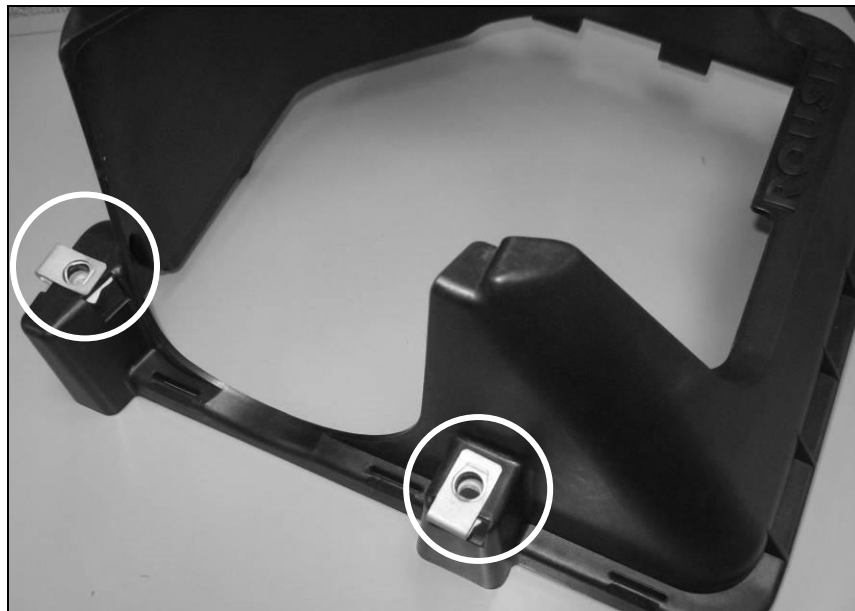



ROUSH[®]
P E R F O R M A N C E

PREMIUM FUEL REQUIRED – NOT E85 COMPATIBLE

3. Slide the MAF tube and filter assembly through the bottom opening and into the new ROUSH air box lid (1111-9A600).



4. Install the EPDM close out seal (1111-9645) around the MAF Tube and clip into the top edges of the upper air box tray.





ROUSH[®]
P E R F O R M A N C E

PREMIUM FUEL REQUIRED – NOT E85 COMPATIBLE

5. Secure the MAF tube to the air box lid using the two (2) M8x25 bolts (W500224) supplied in Hardware Kit A (11SC-TVSHKA). Torque to 20 Nm.



6. Place the new ROUSH air box lid assembly (air box lid / filter / MAF tube) into the vehicle. Snap the three lower air box clips into position securing the upper lid assembly.





ROUSH[®]
P E R F O R M A N C E

PREMIUM FUEL REQUIRED – NOT E85 COMPATIBLE

7. Install the new Clean Air Tube Assembly (11SC-9B659) into position between the throttle body and the MAF tube. Tighten the clamps on either end.
Install the small vacuum fitting (P217N) found in Hardware Kit A into the middle port on the clean air tube and connect the Boost Bypass hose to this fitting.
Install the larger vacuum fitting (P2233A) found in Hardware Kit A into the forward port on the clean air tube and connect the Brake Booster Aspirator hose to the this fitting.
Connect the new PCV Fresh Air Inlet line (AR3Z-6758) to the cam cover and route to the quick connect fitting on the clean air tube. You may need to rotate the fittings inside the tube to get proper orientation of the line once installed.

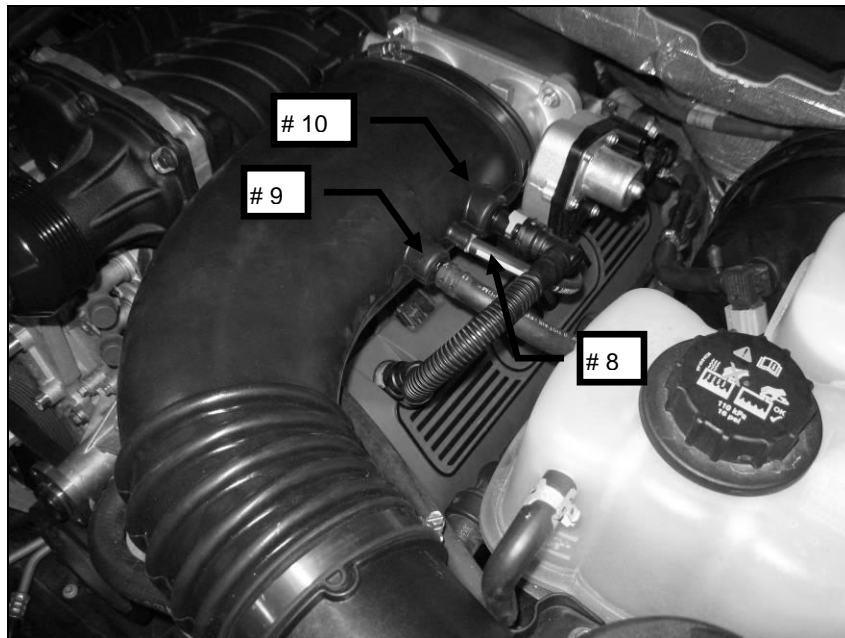

8. Re-connect the MAF Sensor electrical connector. Be sure to push the red lock into position once the connection has been made.

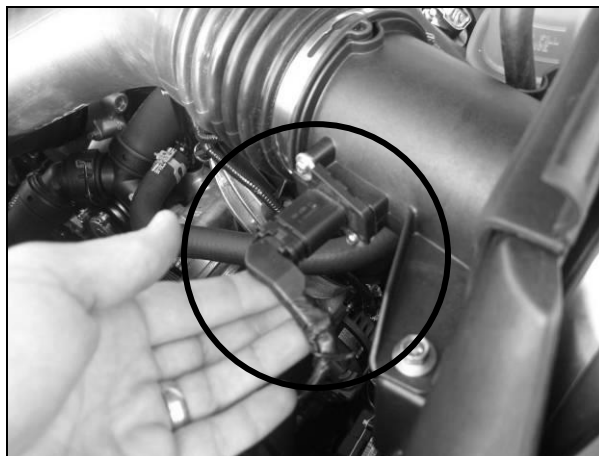



PREMIUM FUEL REQUIRED – NOT E85 COMPATIBLE

Final Assembly

1. Re-install the passenger side headlamp assembly, reversing the order of removal.
2. Fill the engine cooling system (using a proper coolant mixture) to the marked level on the radiator degas bottle. Make sure the radiator petcock is closed tightly.
3. Using the same coolant mixture, fill the intercooler system through the degas bottle. The coolant should be approximately one inch below the top of the cap. Install the degas bottle cap (9C3Z-8101) and tighten when full.

Important: Both coolant systems can trap a large amount of air. It is very important to verify that the air is purged and that coolant is flowing properly through both systems. Roush recommends vacuum filling both systems to properly evacuate the trapped air.

4. Inspect all under hood wiring harnesses for potential interference issues. Use zip ties to safely position the harness away from any areas of concern.
5. If the PCM was removed and shipped to ROUSH for a ROUSH performed flash, reinstall it once the PCM is returned from ROUSH. If you are equipped with a SAE J2534 pass through device, refer to the PCM Flashing section when installation is complete. **DO NOT ATTEMPT TO REINSTALL THE PCM AND START THE VEHICLE IF THE PCM IS NOT EQUIPPED WITH A ROUSH CALIBRATION. OPERATING THE ENGINE WITHOUT THE RECALIBRATED PCM WILL RESULT IN ENGINE DAMAGE OR FAILURE AND WILL VOID THE WARRANTY.**
6. Re-install the battery into the vehicle and make the terminal connections by connecting the positive (+) cable first then connecting the negative (-) cable.
7. Reconnect the Fuel Pump Control Module electrical connector located above the spare tire on the frame.
8. Place the PCM warning sticker above the PCM on the cowl of the vehicle.

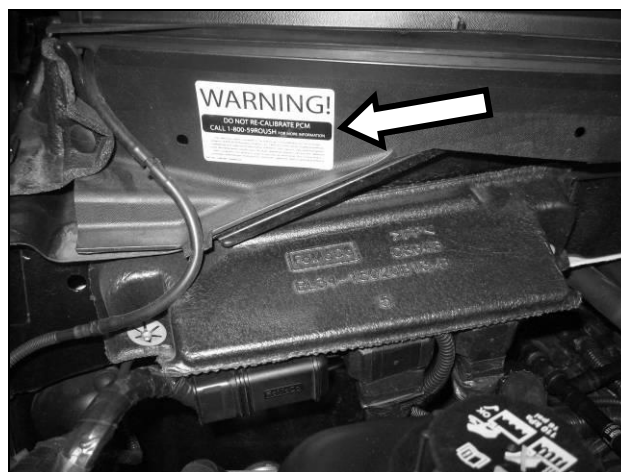



ROUSH[®]
P E R F O R M A N C E

PREMIUM FUEL REQUIRED – NOT E85 COMPATIBLE

9. The Belt Routing Diagram (13116E072) is to be placed on the underside of the hood, on the driver side, opposite of the factory Vehicle Emission Control Information decal.
10. Place the Fuel Door Decal (R0711005) on the backside of the fuel door. With the supercharger system installed, the vehicle is no longer E85 Compatible. If your vehicle has a Flex-Fuel badge, it is recommended that this also be removed at this time.

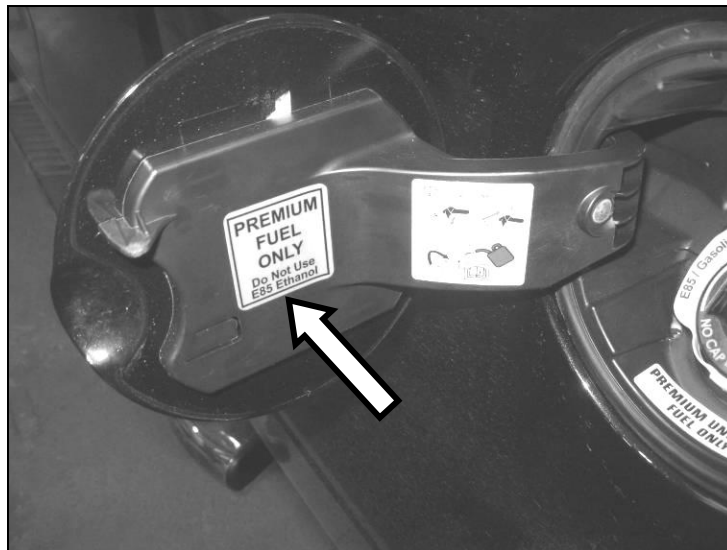

11. Place the Premium Unleaded Fuel Only Decal (13109A095) inside the fuel door, below the fuel filler neck.

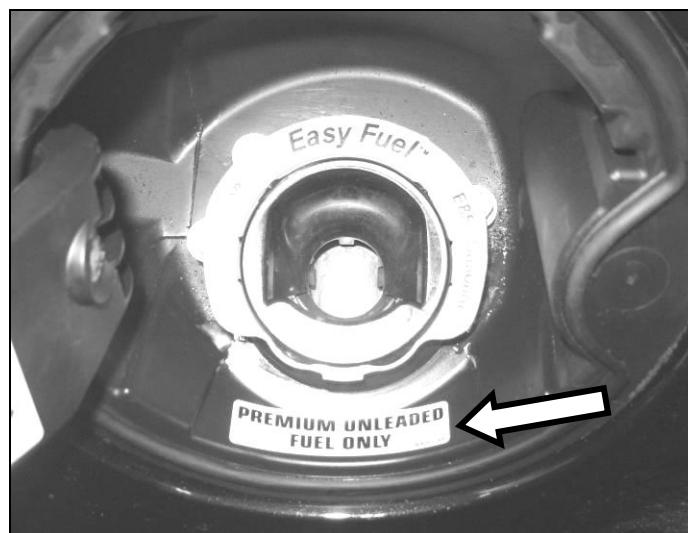



ROUSH
P E R F O R M A N C E

PREMIUM FUEL REQUIRED – NOT E85 COMPATIBLE

12. Place the “Premium Fuel” clear decal with white lettering on the instrument cluster bezel, on the flat area below the small center gauges as shown.

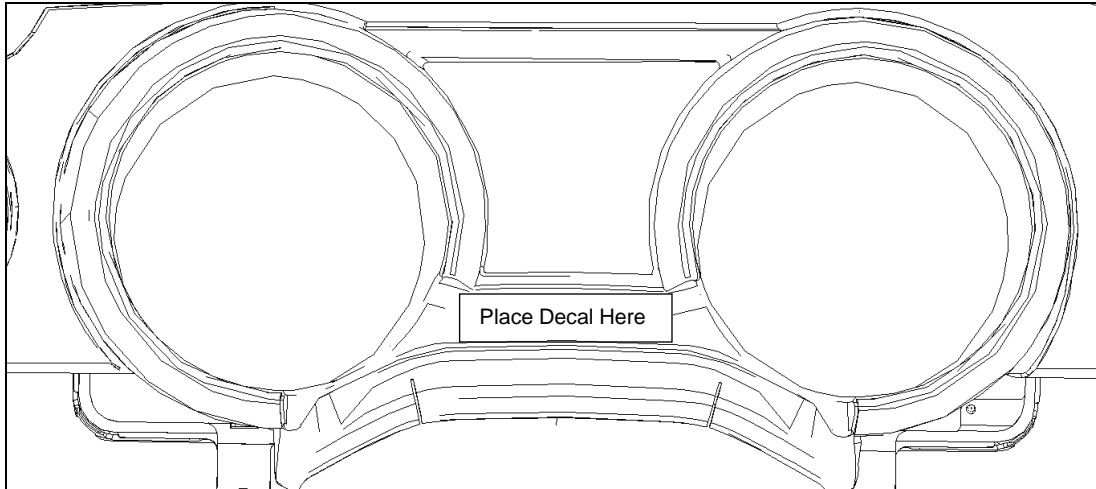

13. Place the EO Label (D418**-9A095EO) under hood in a visible location (on the bottom side of the hood or along the radiator close out panel).
14. **If performing the PCM Flash procedure, proceed to the “PCM Flashing” section. If the PCM was sent to ROUSH for the Optional ROUSH Performed Flash and it has been reinstalled,** start the engine and check for unusual noise, dash service lights, and/or unusual operation. If problems are detected, immediately stop the engine or vehicle, diagnose and repair the problem.
15. Congratulations, you can now go enjoy your new ROUSHcharged 5.0L F-150.

PCM Flashing

1. If equipped with an SAE J2534 pass through device, refer to the RDT-CALIM calibration installation manual, found online at rdt.roush.com for PCM flashing. The RDT-CALIM manual will guide you through the ROUSH Diagnostic Tool (RDT) software installation process and the ROUSH PCM flashing procedure. **OPERATING THE ENGINE WITHOUT THE RECALIBRATED PCM WILL RESULT IN ENGINE DAMAGE OR FAILURE AND WILL VOID THE WARRANTY.**
2. Once the PCM has been successfully re-calibrated, start the engine and check for unusual noises, dash service lights, and unusual operation. If problems are detected, immediately stop the engine or vehicle, diagnose and repair the problem.