

iBoard[®]



Scan for
Installation Video

iBoard[®] by APS

PART#: IB-212C&H

READ INSTRUCTIONS CAREFULLY BEFORE STARTING INSTALLATION. REMOVE CONTENTS FROM BOX AND VERIFY ALL PARTS ARE PRESENT. ASSISTANCE IS RECOMMENDED.

*ROCKER PANEL MOUNT
*NO DRILLING REQUIRED

Fastener Size	Tightening Torque (ft-lbs)	Required
6mm	6-7	X
8mm	16-18	✓
10mm	31-32	X
12mm	56-58	X
14mm	92-94	X

PART LIST

Driver Side Step Bar

Front
↑

Passenger Side Step Bar

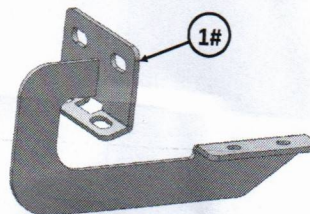
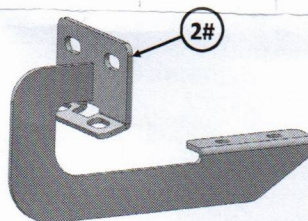
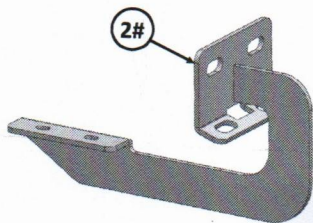
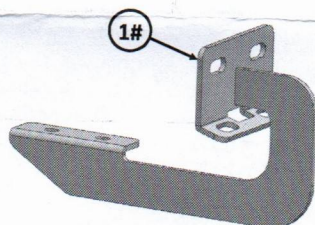

Customer Support: info@iboardauto.com

iBoard®



Scan for
Installation Video

Mounting Bracket List

Item	QTY	Description	Item	QTY	Description
1#	2	Driver Front / Passenger Rear Mounting Brackets	2#	2	Passenger Front / Driver Rear Mounting Brackets

Hardware Package A (For Bracket Installation)

Item	QTY	Description	Item	QTY	Description
1#	8	M8X1.25-30mm Hex Bolts	5#	16	M8 Lock Washers
2#	8	M8X1.25-25mm Hex Bolts	6#	8	M8X1.25 Hex Nuts
3#	8	M8 Large Flat Washers	7#	8	M8 Clip Nuts
4#	16	M8 Flat Washers			



1 #



2 #



3 #



4 #



5 #



6 #



7 #

Hardware Package B (For Stainless Steel Step Bar Installation)

Item	QTY	Description	Item	QTY	Description
1#	8	M8X1.25-35mm Carriage Bolts	3#	8	M8 Nylon Lock Nuts
2#	8	M8 Large Flat Washers	4#	4	Sliders (Packed with Step Bars)



1 #



2 #



3 #



4 #

Customer Support: info@iboardauto.com

iBoard[®]



Scan for
Installation Video

STEP 1

Starting on the driver side of the vehicle, locate the (2) holes in the bottom of the body panel, (pinch weld), toward the front tire, **(Fig 1)**. Next locate the rectangular opening and (2) small holes in the inner body panel directly above the holes in the pinch weld, **(Figs 1 & 2)**. **NOTE:** The holes on the inner panel may be covered with sealing tape or insulation, remove if equipped.

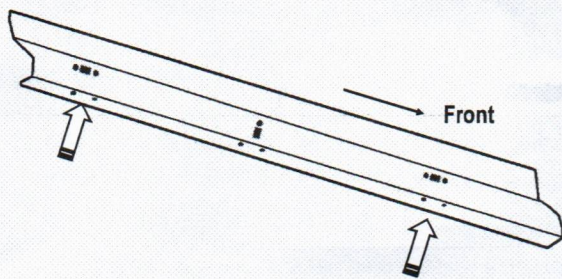

(Fig 1) Driver Side Mounting Locations
(Inner Body Panel Illustrated)

STEP 2

Slide (1) M8 Clip Nut into the rectangular opening with the nut towards the inside. Line up the threaded nut on the clip with the round hole, **(Fig 2)**. Repeat to install the 2nd M8 Clip Nut in remaining hole location.

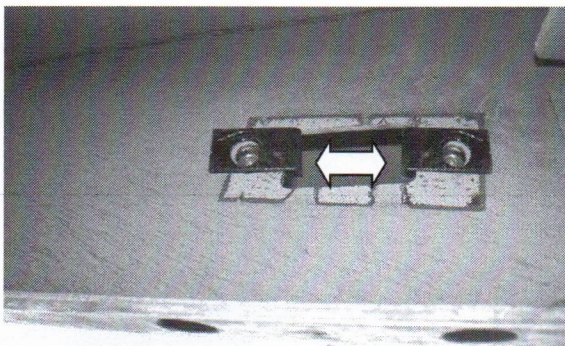

(Fig 2) M8 Clip Nuts Installed
(On Driver Side Front Mounting Location)

STEP 3

Select (1) Driver Front Mounting Bracket, attach the Mounting Bracket to the (2) M8 Clip Nuts with the included (2) M8x1.25-30mm Hex Bolts, (2) M8 Lock Washers and (2) M8 Large Flat Washers, **(Figs 3 & 4)**. Do not fully tighten hardware at this time. The cradle on the Mounting Bracket should face to the front of the vehicle.

NOTE: Depending on model and year, the brake cable may be run on the inside or outside of the Bracket.

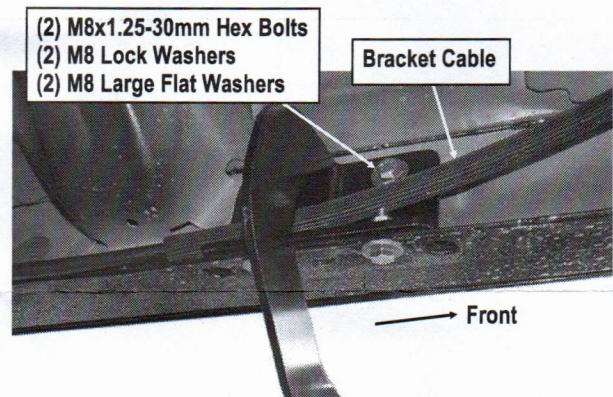

(Fig 3) Driver Front Mounting Bracket Installed

STEP 4

Align the bottom holes on the Driver Front Mounting Bracket with the (2) holes in the pinch weld. Bolt the Bracket to the pinch weld using the included (2) M8x1.25-25mm Hex Bolts, (4) M8 Flat Washers, (2) M8 Lock Washers and (2) M8 Hex Nuts, **(Fig 4)**. Do not fully tighten hardware at this time.

NOTE: Insert the bolts up from the bottom of the pinch weld and through the Bracket.

iBoard®



Scan for
Installation Video

- (2) M8x1.25-25mm Hex Bolts
- (4) M8 Flat Washers
- (2) M8 Lock Washers
- (2) M8 Hex Nuts

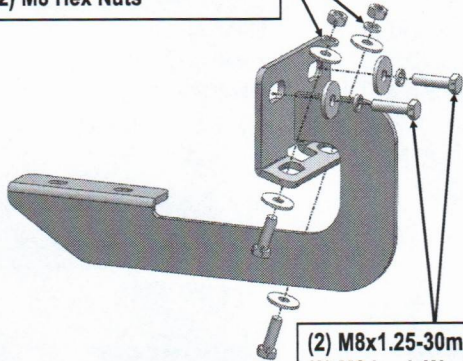

- (2) M8x1.25-30mm Hex Bolts
- (2) M8 Lock Washers
- (2) M8 Large Flat Washers

(Fig 4) Driver Front Mounting Bracket Installation

STEP 5

Move to the Driver Side Rear Mounting Location. Locate the last (2) mounting holes on the pinch weld, (Fig 1). Repeat **Steps 2-4** for Driver Rear Mounting Bracket installation. Do not fully tighten hardware at this time.

NOTE: The cradle on the rear Bracket should face to the rear of the vehicle.

STEP 6

Once all (2) Driver side mounting brackets are installed, then proceed to the Step Bar installation. (Figs 5 & 6)

- (1) Select (1) Slider and (2) M8X1.25-35mm Carriage Bolts;
- (2) Install (2) M8X1.25-35mm Carriage Bolts in (1) Slider.
- (3) Slide the Slider (with carriage bolts) to the **Step Bar**.
- (4) Repeat to install the other (1) slider to the step bar.
- (5) Attach the Step Bar (with the Sliders) onto the installed mounting brackets. Position the Sliders to the installed brackets. Secure the Step Bar to the installed Brackets by using (4) M8 Large Flat Washers and (4) M8 Nylon Lock Nuts and (2) Sliders, (Fig 6). Do not fully tighten hardware at this time.

Note: The Sliders are packed with the Step Bars.

Level and adjust the Step Bar and fully tighten all hardware.

Repeat **Steps 1-6** for the other side Step Bar installation. **The installation is completed!!!**

Attention

Do periodic inspections to the installation to make sure that all hardware is secure and tight.

In order to protect your bars/boards, please use mild soap/non-abrasive products for cleaning only.

iBoard®



Scan for
Installation Video

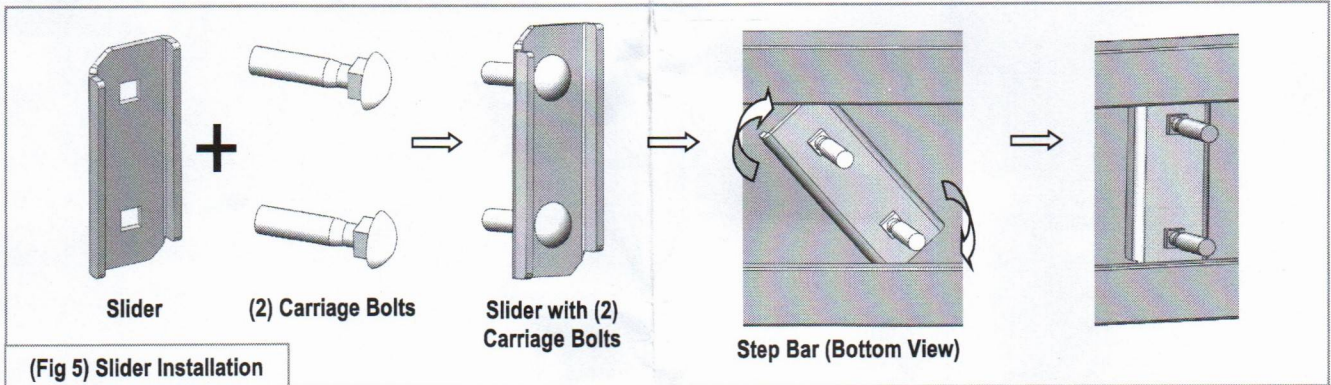

(Fig 5) Slider Installation

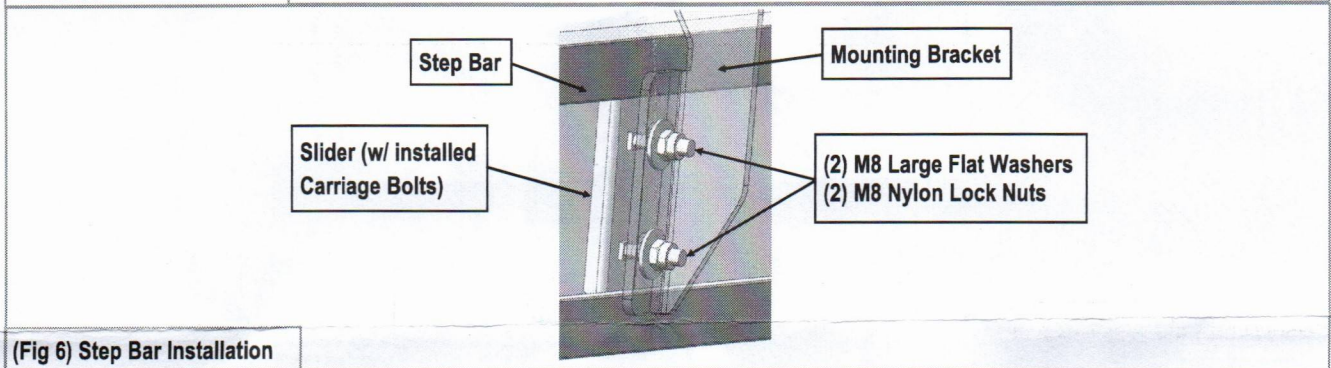

(Fig 6) Step Bar Installation