

PARTS LIST:

1	Front Bumper Assembly	2	8-1.25mm x 25mm Hex Bolts
1	Driver/left "L" Light Bar Bracket (Inner LED light)	2	8-1.25mm x 16mm Hex Bolts
1	Passenger/right "L" Light Bar Bracket (inner LED light)	6	8mm x 24mm x 2mm Flat Washers
1	License Plate Bracket	4	8mm Lock Washers
2	Plastic Plugs for license plate mount	2	8mm Hex Nuts
4	12-1.75mm x 40mm Hex Bolts	2	6-1.0mm x 20mm Button Head Bolts
8	12mm x 32mm x 3mm Flat Washers	4	6mm x 18mm x 1.6mm Flat Washers
4	12mm Lock Washers	2	6mm Nylon Lock Nuts
4	12mm Hex Nuts	1	4mm Wrench

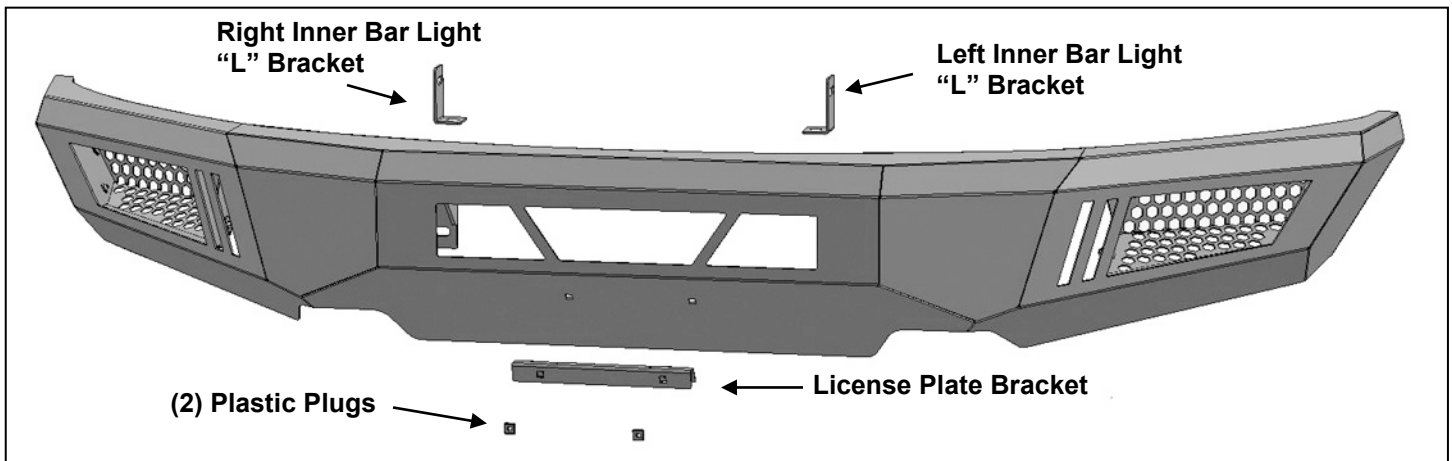

PROCEDURE:

REMOVE CONTENTS FROM BOX. VERIFY ALL PARTS ARE PRESENT. READ INSTRUCTIONS CAREFULLY BEFORE STARTING INSTALLATION. ASSISTANCE IS RECOMMENDED TO AVOID POSSIBLE INJURY OR DAMAGE TO THE VEHICLE.

1. Remove the hardware attaching the inner splash panels in the fenders to the back of the bumper. Remove skid plate and license plate, **(Figure 1)**.
2. Open the hood and remove the hardware attaching the hood release lever to the steel bracket attached to the back of the bumper, **(Figure 2)**. Also remove the screws attaching the plastic fascia to the top of the bracket, **(Figure 3)**.
3. Place blocks or jack stands under the front bumper to support it during mounting bolt removal. Once the bumper has been safely supported, remove the (4) large hex nuts. (2 per side) from the back of the bumper brackets and remove the bumper, **(Figures 4 & 5)**. **WARNING!** Assistance is required to hold the bumper in place during bolt removal to prevent the bumper from falling.
4. Remove the steel hood release mounting bracket from the back of the bumper, **(Figure 6)**. Reuse the factory hardware to attach the bracket to the mounting tabs on the back of the plastic fascia. Reattach the hood release lever to the steel bracket, **(Figure 7)**. Tighten hardware at this time.
5. Carefully unwrap the Bumper assembly. Determine if accessory lights, (not included), will be installed at this time.

Center LED light installation (sold separately). **NOTE:** Lights may also be installed after Bumper has been installed.

- a. Select the L/R "L" Brackets, **(Figure 8)**. **NOTE:** "L" Brackets are offset for universal fitment for most LED bar style lights. Attach the brackets to the top of the (2) tabs on the back of the Bumper with the included 8mm x 25mm Hex Bolts, (4) 8mm Flat Washers, (2) 8mm Lock Washers and (2) 8mm Hex Nuts, **(Figure 9)**. Do not fully tighten hardware at this time.
- b. Attach the LED light assembly to the "L" Brackets with the included (2) 8mm x 16mm Hex Bolts, (2) 8mm Lock Washers and (2) 8mm Flat Washers, **(Figures 8 & 9)**. Do not fully tighten hardware at

this time. **NOTE:** "L" Brackets may require modification for hardware larger than 8mm or use brackets supplied with light if possible.

- c. Adjust light position and tighten hardware.
- d. Follow light manufacturer's instructions to wire the light to the vehicle's electrical system once Bumper has been fully installed.

LED light installation at ends of bumper (sold separately).

- a. Insert light into opening and up to mounting slots. Check for clearance between front and back of light. If necessary, remove the screens from the back of the openings, **(Figure 10)**.
 - b. Follow the light manufacturer's instructions to attach each light to slot in the top of the light opening, **(Figure 10)**. **NOTE:** On two light systems, attach the flood light to the outer slot and the spot light to the inner slot.
 - c. Repeat the above steps for passenger side light installation.
 - d. Follow light manufacturer's instructions to properly wire the light to the vehicle electrical system.
6. With assistance, position the Bumper Assembly up to the end of the frame. Temporarily support the weight of the Bumper. **WARNING:** To avoid possible injury or damage to the vehicle, do not proceed until the bumper is fully and safely supported. Attach the Bumper to the frame with (4) 12mm x 40mm Hex Bolts, (8) 12mm Flat Washers, (4) 12mm Lock Washers and (4) 12mm Hex Nuts, **(Figures 11 & 12)**. Do not fully tighten at this time.
 7. Level and adjust the Bumper and fully tighten all hardware.
 8. Attach rubber shroud to back of Bumper, **(Figure 12)**.
 9. If front license plate is required, attach the License Plate Bracket to the holes in the bumper with the included (2) 6mm x 20mm Button Head Screws, (4) 6mm Flat Washers and (2) 6mm Nylon Lock Nuts, **(Figure 13)**. Insert (2) Plastic Plugs into the square holes in the Bracket, **(Figure 13)**. Reuse the factory screws to attach the license plate to the plastic plugs.
 10. Do periodic inspections to the installation to make sure that all hardware is secure and tight.

To protect your investment, Do not use any type of polish or wax that may contain abrasives that could damage the finish. Mild soap may be used to clean the Bumper assembly.

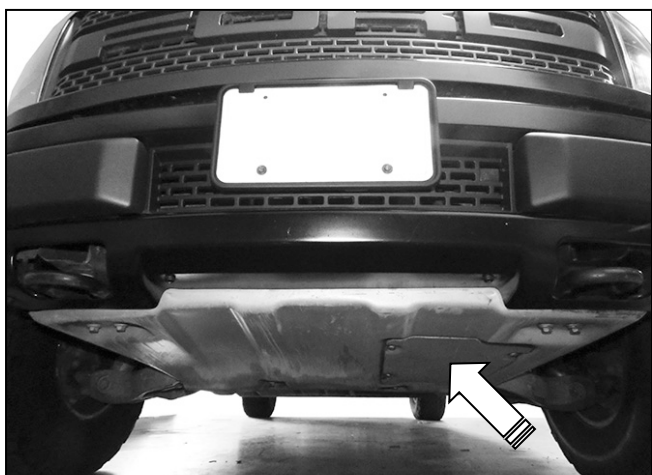

(Fig 1) Remove license plate and skid plate (arrow)

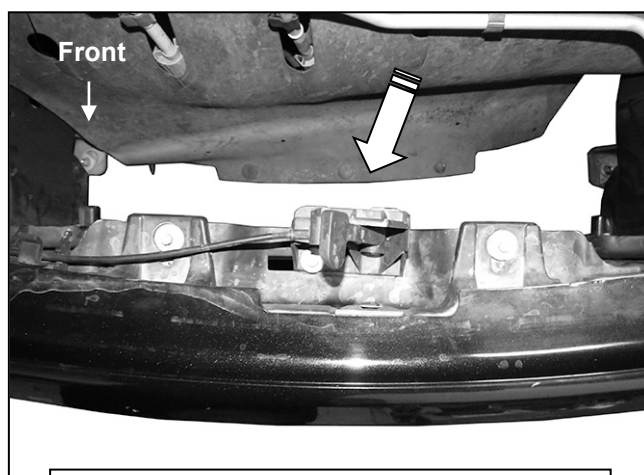

(Fig 2) Open hood and remove hood latch (arrow) with cable from bracket on back of bumper. Also release clips attaching rubber shroud to back of bumper

Driver Side Installation Pictured

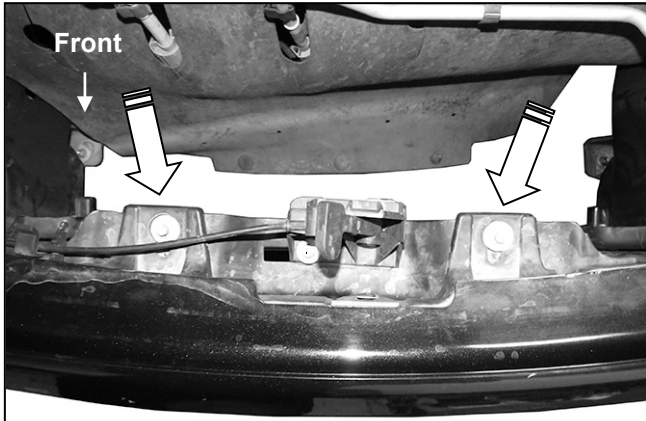

(Fig 3) Remove (2) bolts attaching plastic fascia body panel to top of bracket on back of bumper

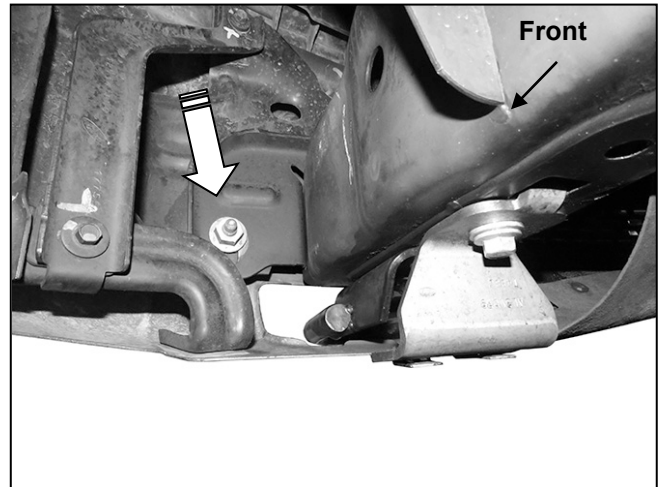

(Fig 4) Remove hex nuts (2 per side) from back of bumper brackets to remove bumper



(Fig 5) Remove bumper assembly

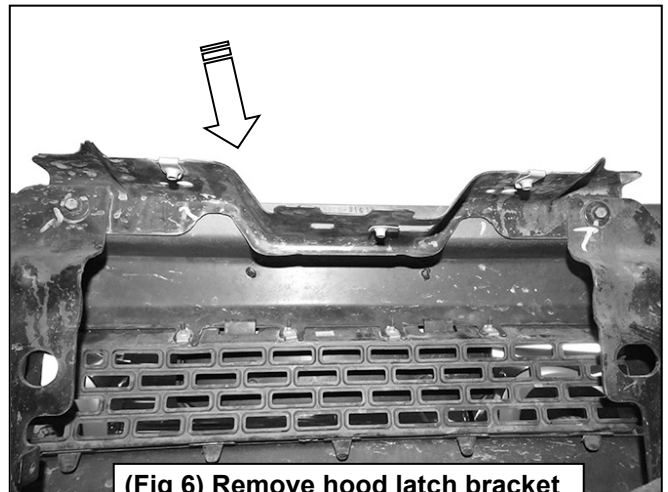

(Fig 6) Remove hood latch bracket (arrow) from back of bumper

Driver Side Installation Pictured

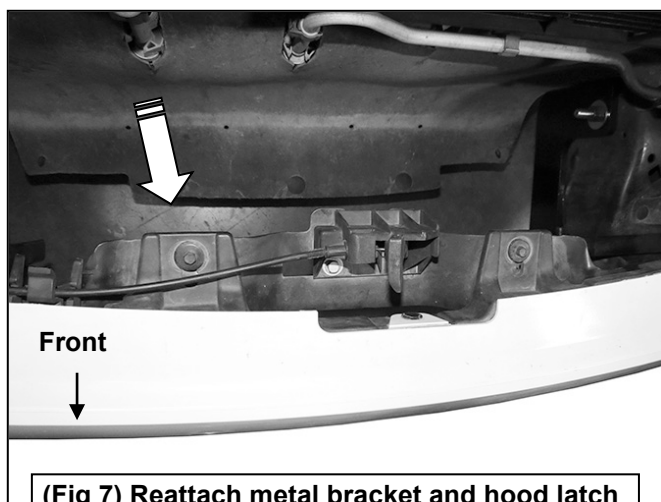

Front

(Fig 7) Reattach metal bracket and hood latch to bottom of tabs on plastic fascia body panel

WARNING! Do not remove bumper bolts unless the bumper is properly supported on blocks or stands or the bumper may fall.

8mm x 16mm Hex Bolt
8mm Lock Washer
8mm Flat Washer

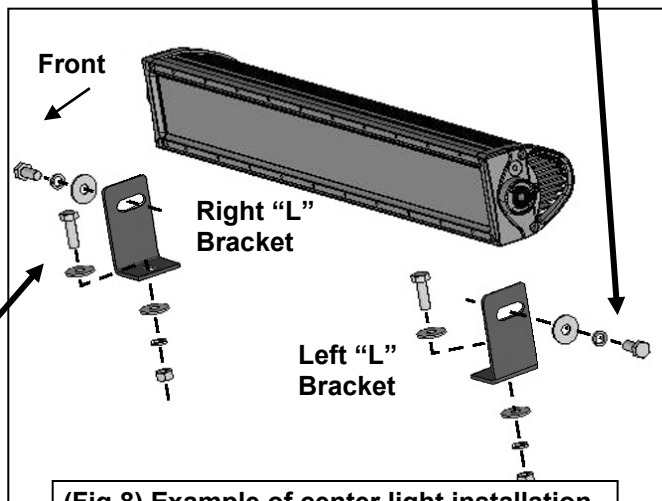

Front

Right "L" Bracket

Left "L" Bracket

(Fig 8) Example of center light installation

8mm x 16mm Hex Bolt
8mm Lock Washer
8mm Flat Washer

8mm x 25mm Hex Bolt
(2) 8mm Flat Washers
8mm Lock Washer
8mm Hex Nut

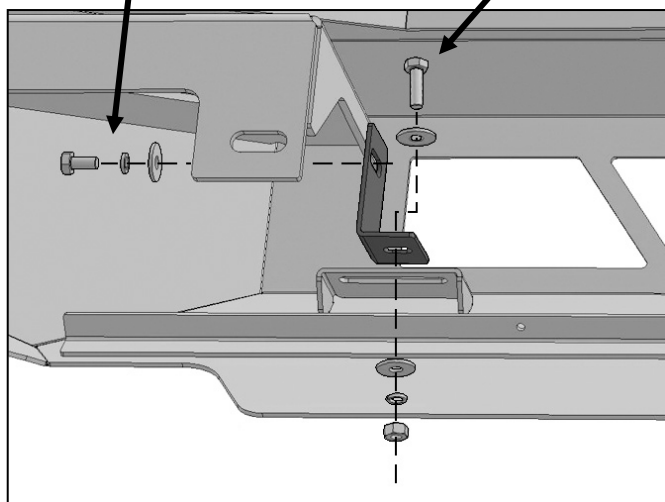

(Fig 9) Attach light (not included) to "L" Bracket

Attach single light to center slot or use inner and outer slots for dual lights

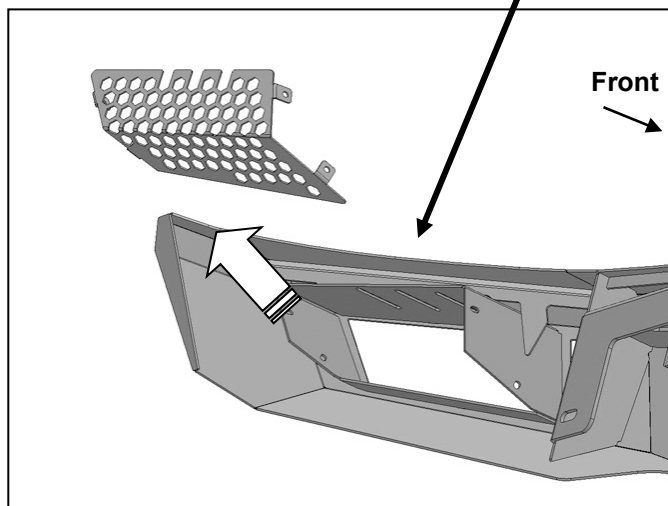

Front

(Fig 10) Remove screens if necessary for clearance/access to outer light mounts

WARNING! Do not crawl under bumper unless the bumper is properly supported on blocks or stands or the bumper may fall.

Driver Side Installation Pictured

WARNING! Do not crawl under bumper unless the bumper is properly supported on blocks or stands or the bumper may fall.

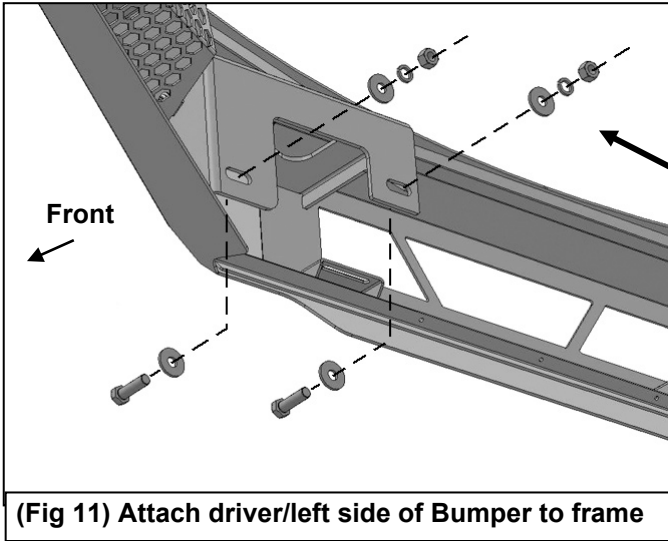

- (2) 12mm x 40mm Hex Bolts
- (4) 12mm Flat Washers
- (2) 12mm Lock Washers
- (2) 12mm Hex Nuts

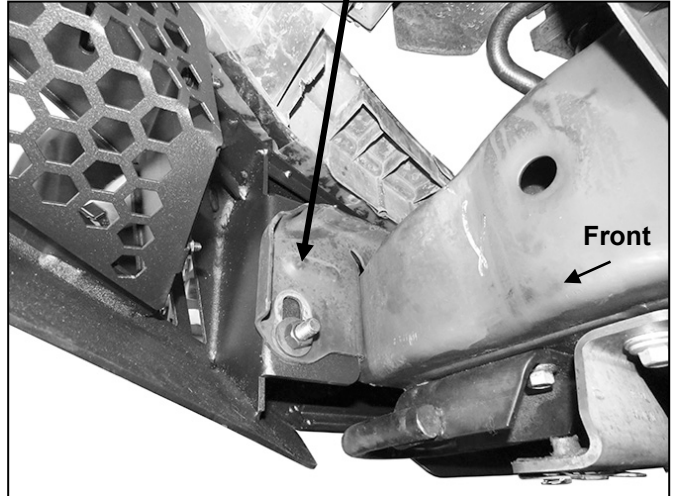

(Fig 12) Driver/left side of Bumper attached to frame (pictured from below). Reattach rubber shroud to tab on back of bumper (Fig 5)

- (2) 6mm x 20mm Button Head Screws
- (4) 6mm Flat Washers
- (2) 6mm Nylon Lock Nuts

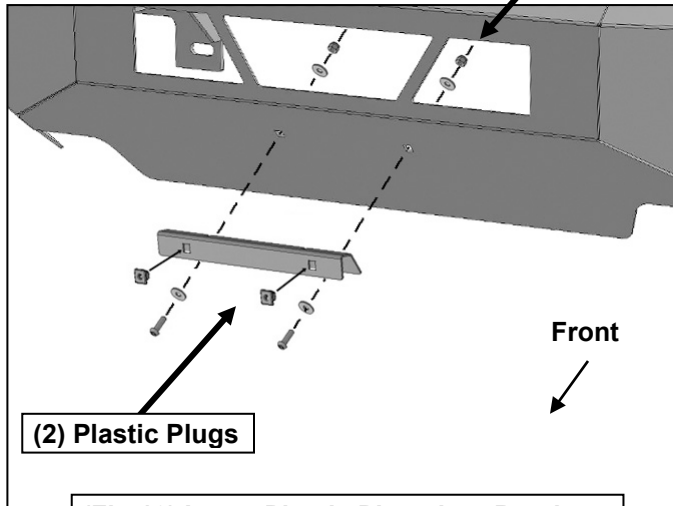

- (2) Plastic Plugs

(Fig 13) Insert Plastic Plugs into Bracket. Attach License Plate to Plastic Plugs

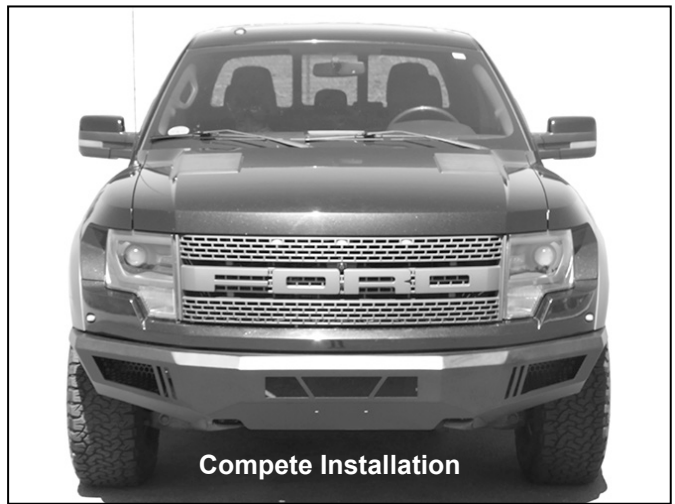

Complete Installation