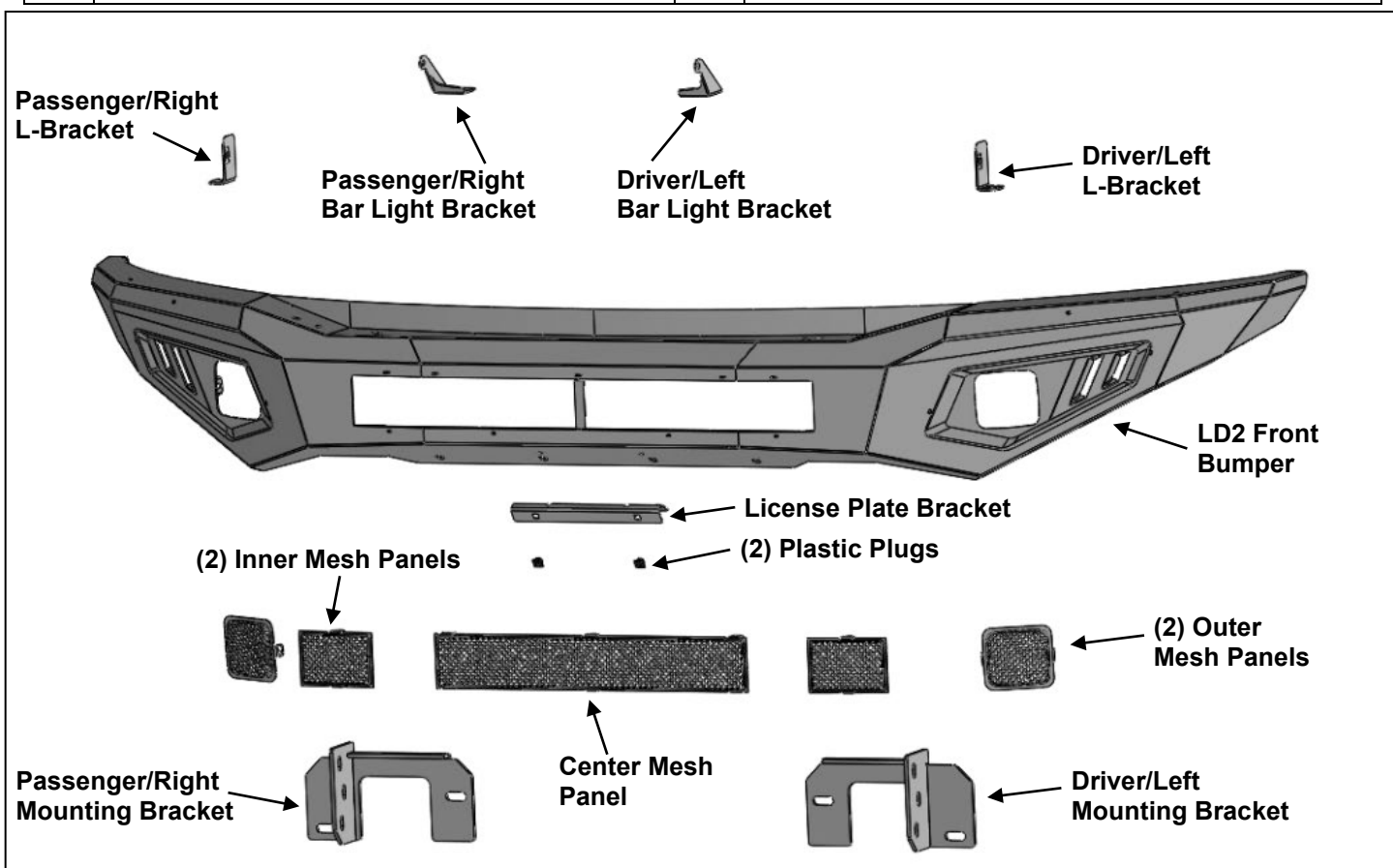

PARTS LIST:

1	Front LD2 Bumper	6	10mm Lock Washers
1	Driver/Left Mounting Bracket	6	10mm Hex Nuts
1	Passenger/Right Mounting Bracket	4	8-1.25mm x 25mm Button Head Bolts
1	License Plate Bracket	2	8-1.25mm x 25mm Hex Bolts
1	Drive/Left Light Bracket	2	8-1.25mm x 16mm Hex Bolts
1	Passenger/Right Light Bracket	14	8mm x 24mm OD x 2mm Flat Washers
1	Driver/Left L-Brackets	8	8mm Lock Washers
1	Passenger/Right L-Brackets	6	8mm Hex Nuts
2	Small Outer Mesh Panels	14	6-1.0mm x 20mm Combo Bolts
2	Small Inner Mesh Panels	2	6-1.0mm x 20mm Button Head Bolts
1	Long Mesh Panel	2	6-1.0mm x 16mm Hex Bolts
2	Plastic License Plugs	6	6mm x 18mm OD x 1.6mm Flat Washers
4	12-1.75mm x 40mm Hex Bolts	2	6mm Lock Washers
8	12mm x 37mm OD x 3mm Flat Washers	14	6mm Flange Hex Nuts
4	12mm Lock Washers	2	6mm Nylon Lock Nuts
4	12mm Hex Nuts	1	5mm Hex Wrench
6	10-1.5mm x 35mm Hex Bolts	1	4mm Hex Wrench
12	10mm x 27mm OD x 3mm Flat Washers		

**PROCEDURE:**

REMOVE CONTENTS FROM BOX. VERIFY ALL PARTS ARE PRESENT. READ INSTRUCTIONS CAREFULLY BEFORE STARTING INSTALLATION. ASSISTANCE IS RECOMMENDED TO AVOID POSSIBLE INJURY OR DAMAGE TO THE VEHICLE.

1. Remove the hardware attaching the inner splash panels in the fenders to the back of the bumper. Remove skid plate and license plate, **(Figure 1)**.

2. Open the hood and remove the hardware attaching the hood release lever to the steel bracket attached to the back of the bumper, **(Figure 2)**. Also remove the screws attaching the plastic fascia to the top of the bracket, **(Figure 3)**.
3. Place blocks or jack stands under the front bumper to support it during mounting bolt removal. Once the bumper has been safely supported, remove the (4) large hex nuts. (2 per side) from the back of the bumper brackets and remove the bumper, **(Figures 4 & 5)**. **WARNING!** Assistance is required to hold the bumper in place during bolt removal to prevent the bumper from falling.
4. Remove the steel hood release mounting bracket from the back of the bumper, **(Figure 6)**. Reuse the factory hardware to attach the bracket to the mounting tabs on the back of the plastic fascia. Reattach the hood release lever to the steel bracket, **(Figure 7)**. Tighten hardware at this time.
5. Select the Driver/Left Mounting Bracket. Attach the Bracket to the bumper bracket on the end of the frame with (2) 12mm x 40mm Hex Bolts, (4) 12mm Flat Washers, (2) 12mm Lock Washers and (2) 12mm Hex Nuts, **(Figures 8—10)**. Do not tighten hardware at this time.
6. Carefully unwrap the Bumper assembly. Determine if Lights, (lights not included), or Mesh Panels will be attached at this time. **IMPORTANT:** It may be easier to attach Center Mesh Panels and/or Lights before attaching the Bumper.

Mesh Panel Installation (do not install Mesh Panels if installing lights).

- a. Select desired Mesh Panels. **NOTE:** Outer Panels are square with rounded corners, Inner panels are rectangular with sharp corners, **(Figure 11)**.
- b. Attach Mesh Panels as needed with the included 6mm Button Head Combo Bolts and 6mm Flange Nuts, **(Figure 11)**. Fully tighten Mesh Panel hardware at this time. Repeat to attach all Panels as desired.

Inner center bar style Light installation (light not included).

- a. Select the Driver/Left L-Bracket. **NOTE:** L-Brackets are offset to adjust for different widths of LED Bar Lights and can be attached on either side as needed.
- b. Attach the L-Bracket to the slot on the back of the Bumper with (1) 8mm x 25mm Hex Bolt, (2) 8mm Flat Washers, (1) 8mm Lock Washer and (1) 8mm Hex Nut, **(Figure 12)**. Repeat this Step to attach (1) Passenger/Right L-Bracket on the other side of the Bumper. **IMPORTANT:** The Bumper features slots designed for 20" and 30" bar style lights. Attach the Brackets to the correct slots in the Bumper. If necessary, hold the light up to the slots to help determine correct slots to use and combination of Brackets.
- c. Attach the Light to the L-Brackets with the hardware included with the light or the supplied (2) 8mm x 16mm Hex Bolts, (2) 8mm Lock Washers and (2) 8mm Flat Washers or (2) 6mm x 16mm Hex Bolts, (2) 6mm Lock Washers and (2) 6mm Flat Washers, **(Figure 13)**. Do not fully tighten hardware at this time.

Top mounted 30" bar style Light (not included).

- a. Remove the (2) rubber plugs from the Driver/Left side mounting holes.
- b. Select the Driver/Left Light Bracket. Attach the Bracket to the top of the Bumper with (2) 8mm x 25mm Button Head Bolts, (4) 8mm Flat Washers, (2) 8mm Lock Washers and (2) 8mm Hex Nuts, **(Figure 14)**. Do not tighten hardware at this time.
- c. Repeat previous Steps to attach the Passenger/Right Light Bracket.
- d. Select the 30" Light, (not included). Attach light to Top Brackets with the hardware included with the light. Adjust the width of the Brackets to the Light and fully tighten bracket hardware.
IMPORTANT: Top Light Brackets are designed to install 30" bar style LED lights with outside length dimensions of 31.653" (804mm) to 32.44" (824mm) only. Fully tighten top light hardware.

Outer cube style Light installation (light not included).

- a. Attach Lights to mounting tabs on back of each end of the Bumper.
7. With assistance, position the Bumper Assembly up to the Mounting Brackets. Temporarily support the weight of the Bumper. **WARNING:** To avoid possible injury or damage to the vehicle, do not proceed until the bumper is fully and safely supported. Attach the Bumper to the Mounting Brackets with (6) 10mm x 35mm Hex Bolts, (12) 10mm Flat Washers, (6) 10mm Lock Washers and (6) 10mm Hex Nuts, **(Figure 15)**. Do not fully tighten at this time.
8. Level and adjust the Bumper and fully tighten all hardware.

9. If front license plate is required, attach the License Plate Bracket to the holes in the bumper with the included (2) 6mm x 20mm Button Head Screws, (4) 6mm Flat Washers and (2) 6mm Nylon Lock Nuts. Insert (2) Plastic Plugs into the square holes in the Bracket, **(Figures 16 & 17)**. Reuse the factory screws to attach the license plate to the plastic plugs.
10. Do periodic inspections to the installation to make sure that all hardware is secure and tight.

To protect your investment, Do not use any type of polish or wax that may contain abrasives that could damage the finish. Mild soap may be used to clean the Bumper assembly.

Driver/Left Side Installation Pictured

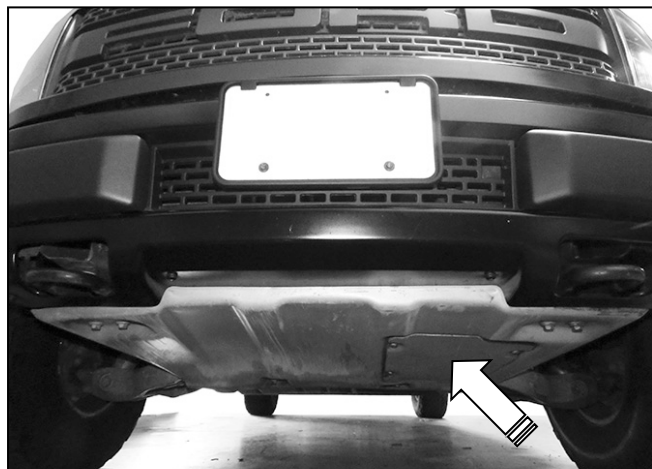

(Fig 1) Remove license plate and skid plate (arrow)

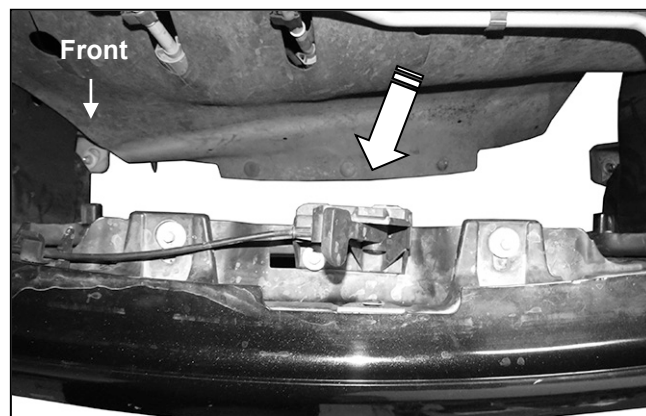

(Fig 2) Open hood and remove hood latch (arrow) with cable from bracket on back of bumper. Also release clips attaching rubber shroud to back of bumper

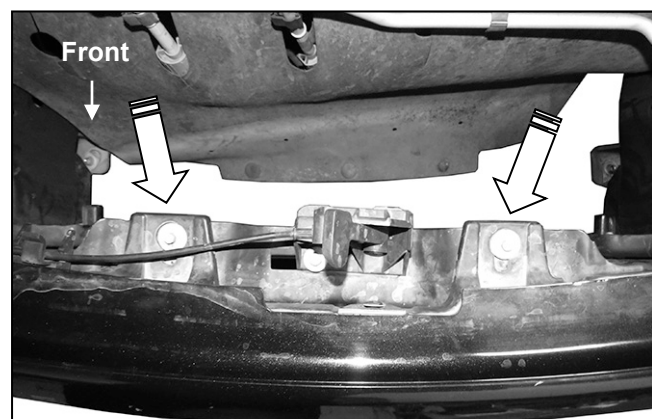

(Fig 3) Remove (2) bolts attaching plastic fascia body panel to top of bracket on back of bumper

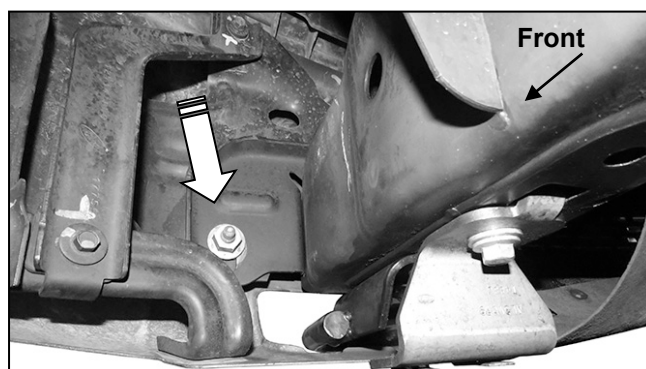

(Fig 4) Remove hex nuts (2 per side) from back of bumper brackets to remove bumper

Driver/Left Side Installation Pictured

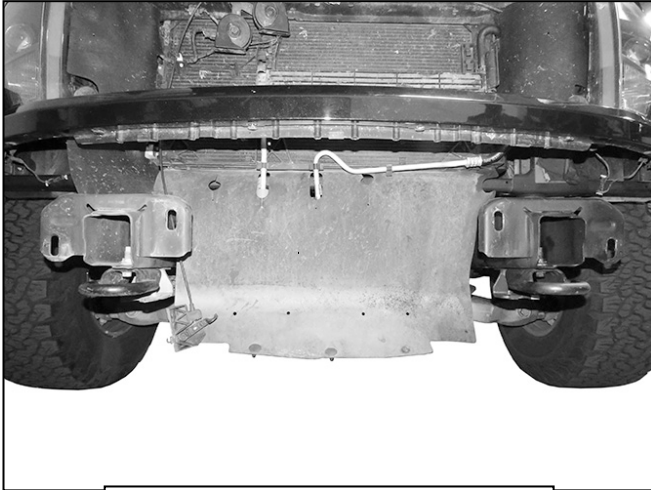

(Fig 5) Remove bumper assembly

WARNING! Do not remove bumper bolts unless the bumper is properly supported on blocks or stands or the bumper may fall.

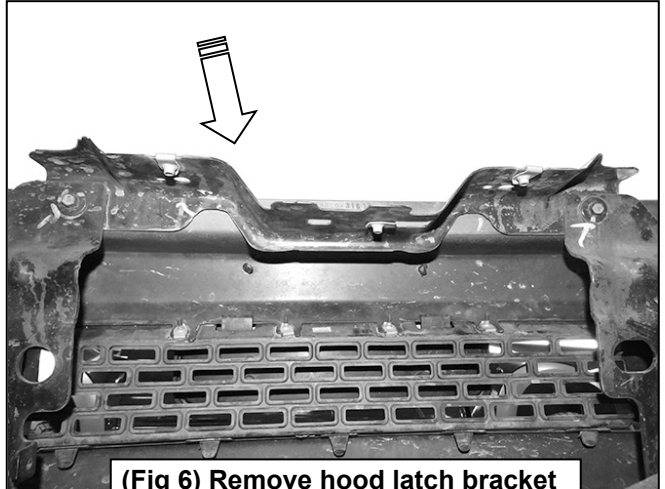

(Fig 6) Remove hood latch bracket (arrow) from back of bumper



(Fig 7) Reattach metal bracket and hood latch to bottom of tabs on plastic fascia body panel

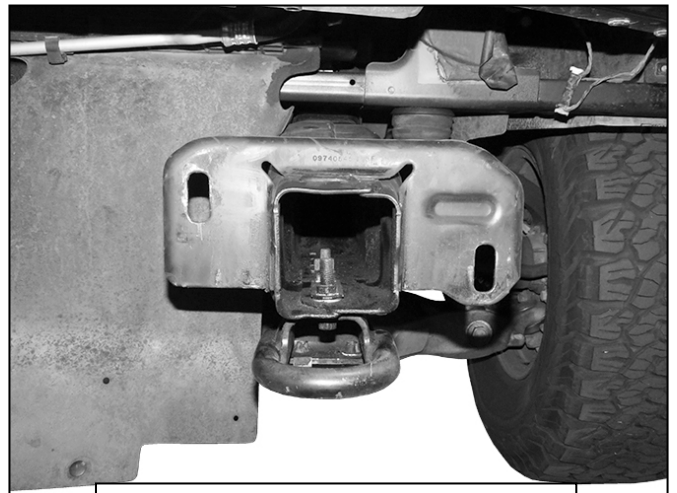

(Fig 8) Driver/Left mounting

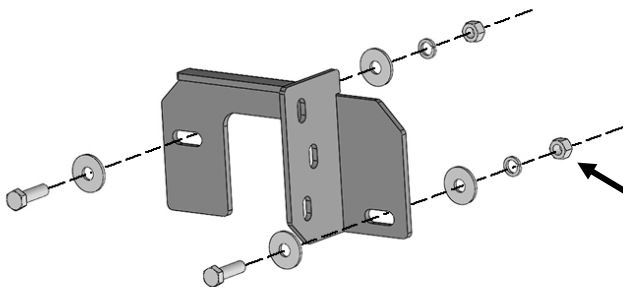

(Fig 9) Attach Driver/Left Mounting Bracket to the bumper flange on the end of frame

- (2) 12mm x 40mm Hex Bolts
- (4) 12mm Flat Washers
- (2) 12mm Lock Washers
- (2) 12mm Hex Nuts

Driver/Left Side Installation Pictured

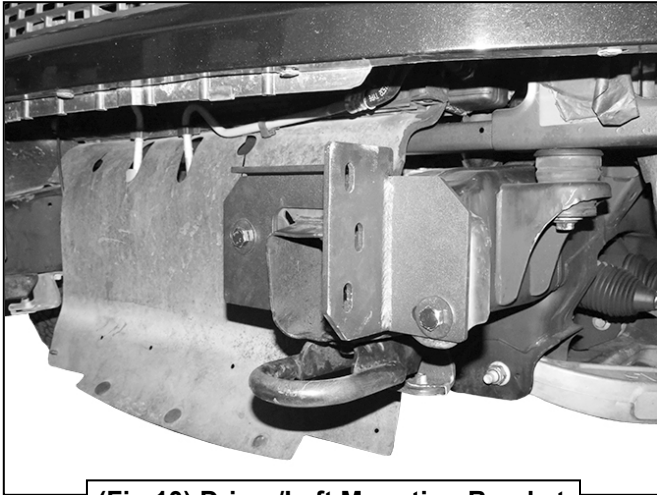

(Fig 10) Driver/Left Mounting Bracket attached to the mounting location

6mm Button Head Combo Bolts
6mm Flange Hex Nuts

8mm x 25mm Hex Bolt
(2) 8mm Flat Washers
8mm Lock Washer
8mm Hex Nut

Inner Mesh Panel

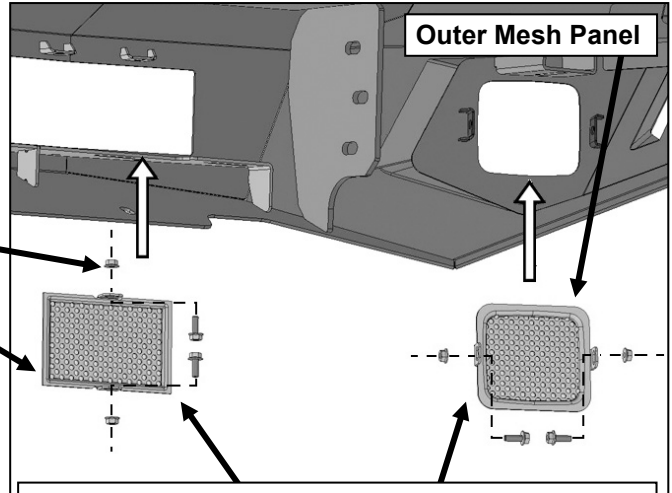

(Fig 11) Attach Mesh Fill Panels as desired to fill unused openings for lights (lights not included)

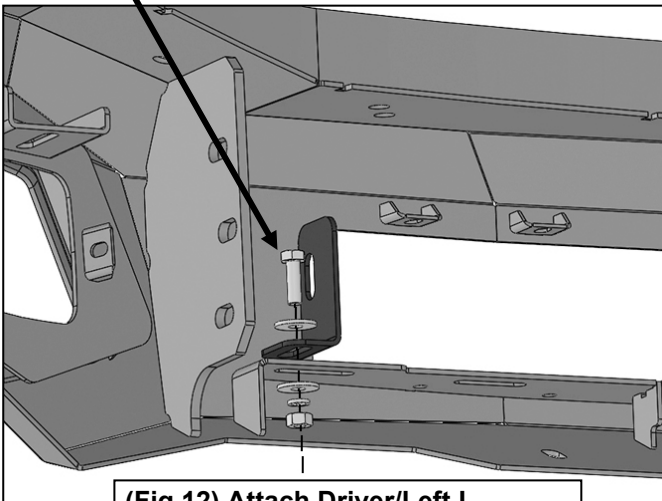

(Fig 12) Attach Driver/Left L-Bracket to the back of the Bumper

8mm x 16mm Hex Bolt
8mm Lock Washer
8mm Flat Washer
Or
6mm x 16mm Hex Bolt
6mm Lock Washer
6mm Flat Washer

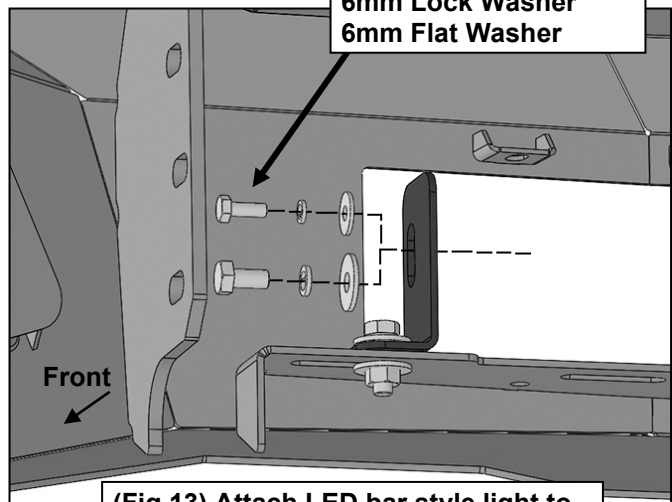

(Fig 13) Attach LED bar style light to L-Brackets (light available separately)

Driver/Left Side Installation Pictured

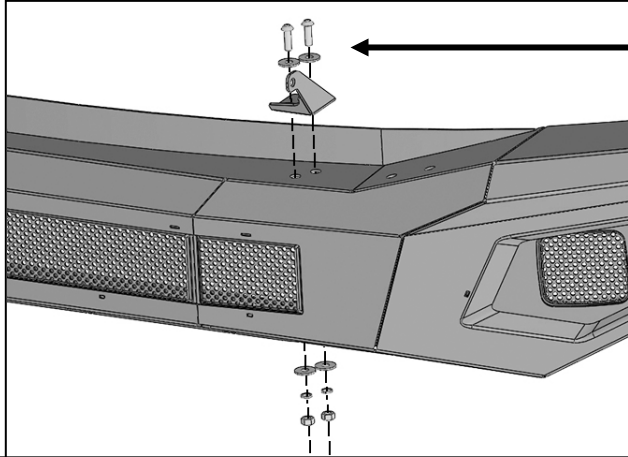

- (2) 8mm x 25mm Button Head Bolts
- (4) 8mm Flat Washers
- (2) 8mm Lock Washers
- (2) 8mm Hex Nuts

WARNING! Do not crawl under bumper unless the bumper is properly supported on blocks or stands or the bumper may fall.

(Fig 14) Remove rubber plugs to attach Top Light Bracket to Bumper. Note: Measure width of LED light (light only) before installation of Top Light Brackets

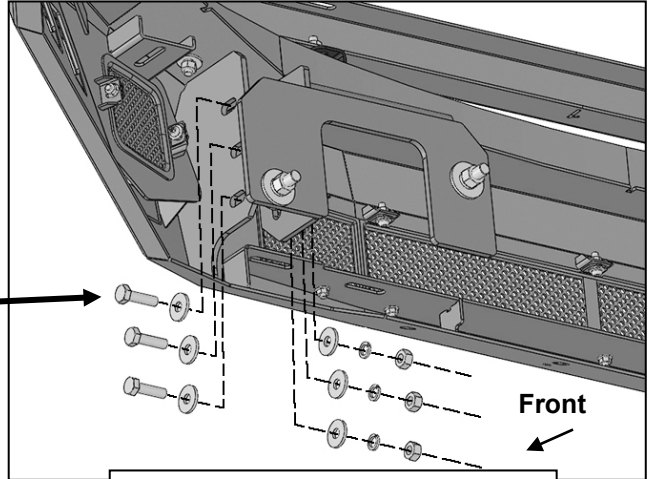

- (3) 10mm x 35mm Hex Bolts
- (6) 10mm Flat Washers
- (3) 10mm Lock Washers
- (3) 10mm Hex Nuts

(Fig 15) Attach Driver/Left side of Bumper to the Mounting Bracket

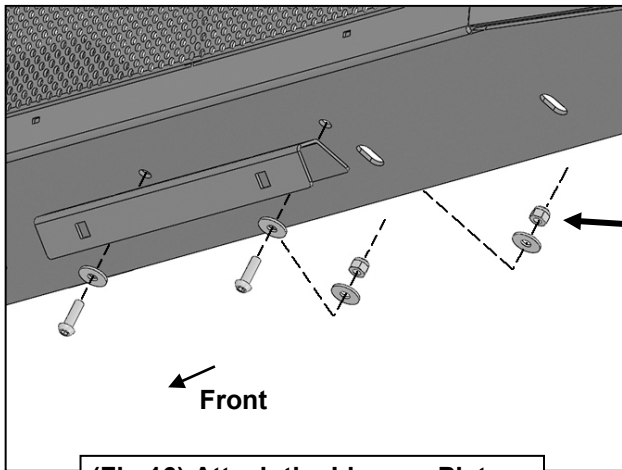

- (2) 6mm x 20mm Button Head Screws
- (4) 6mm Flat Washers
- (2) 6mm Nylon Lock Nuts

(Fig 16) Attach the License Plate Bracket to the front of the Bumper

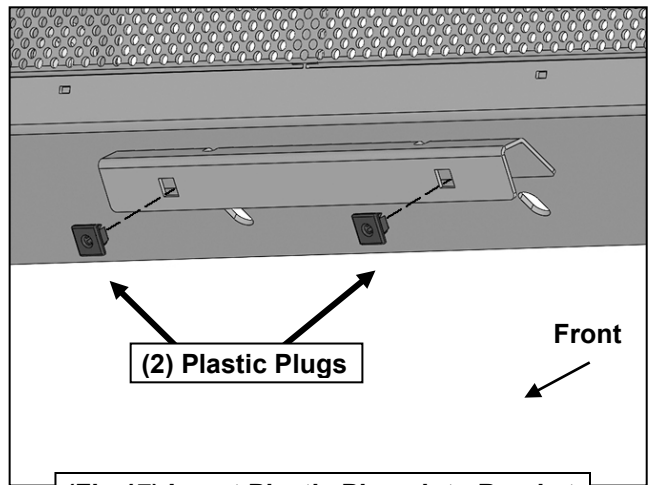

(Fig 17) Insert Plastic Plugs into Bracket