

INSTALLATION INSTRUCTIONS

PRO SERIES REAR BUMPER



APPLICATION:
2015-2020 FORD F-150, 2017-2020 FORD F-150 RAPTOR
PART NUMBER:
58-421015, 58-421145

CONTENT			
ITEM	QUANTITY	DESCRIPTION	TOOLS NEEDED
1	1	REAR BUMPER	10MM SOCKET
2	1	DRIVER MONTING BRACKET	10MM WRENCH
3	1	PASSENGER MOUNTING BRACKET	19MM SOCKET
4	4	SENSOR L-TAB	19MM WRENCH
5	4	SENSOR HOLE PLUG	TRIM TOOL
6	6	M12 SPLIT LOCK WASHER (YELLOW ZINC)	RATCHET
7	6	M12 SERRATED FLANGE BOLT (YELLOW ZINC)	TORQUE WRENCH
8	12	M12 FLAT WASHER (YELLOW ZINC)	
9	6	M12 HEX NUT (YELLOW ZINC)	
10	4	M6 FLAT WASHER (YELLOW ZINC)	
11	4	M6 HEX NUT (YELLOW ZINC)	
12	4	M6 CARRIAGE BOLT (YELLOW ZINC)	
13	4	M6 SPLIT LOCK WASHER (YELLOW ZINC)	
14	6	M6 BUTTON HEAD BOLT (BLACK ZINC)	
15	6	M6 SERRATED FLANGE NUT (BLACK ZINC)	
16	6	M6 FLAT WASHER (BLACK ZINC)	

ANTI-SEIZE LUBRICANT MUST BE USED ON ALL STAINLESS STEEL FASTENERS TO PREVENT THREAD DAMAGE AND GALLING

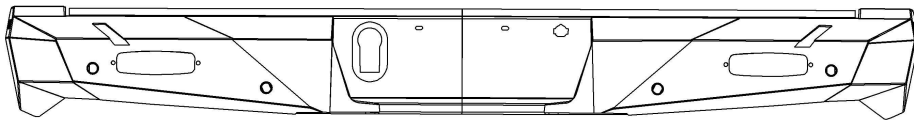
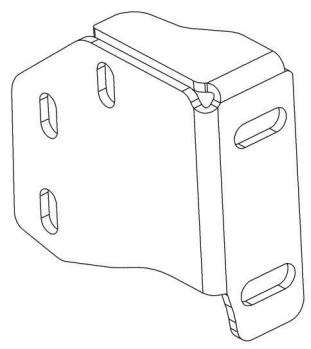
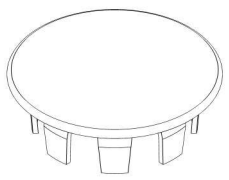
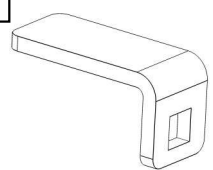
<p>ITEM 1</p>  <p>58-421145 Similar</p>	<p>ITEM 2</p> 
<p>ITEM 5</p> 	<p>ITEM 4</p> 

PROCEDURE

1. Remove contents from box, verify if all parts listed are present and free from damage. Carefully read and understand all instructions before attempting installation.
Failure to identify damage before installation could lead to a rejection of any claim.

2. Start removing the rear bumper by removing the plastic portion. It should pop off of the vehicle. You may need a trim removal tool.
3. Remove the 5 bolts on each side of the bumper to remove the end caps. **See Figure 1-2**

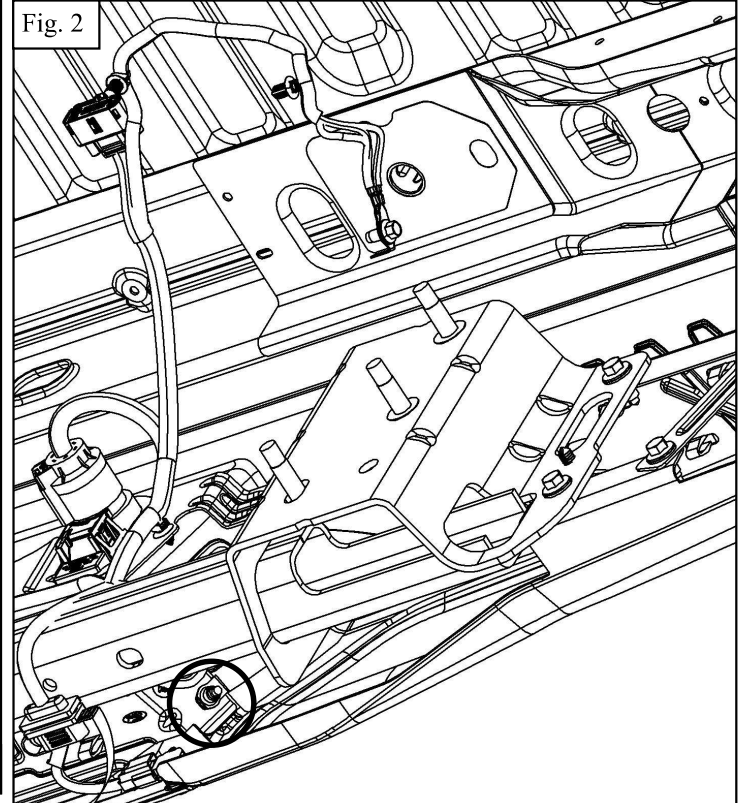
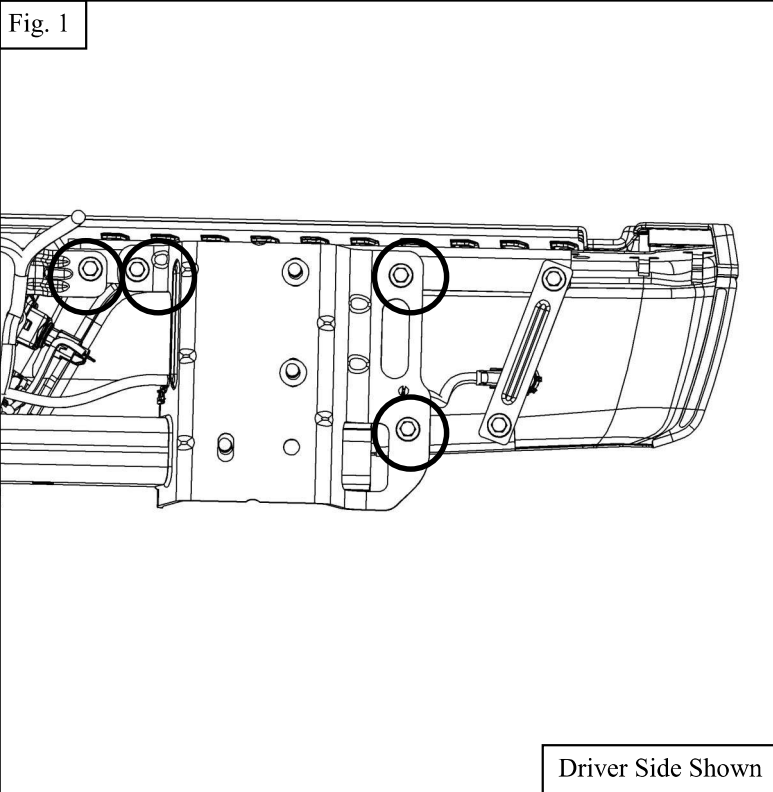

4. After removing the bumper pieces, you will be left with the exposed hitch assembly. Locate the mounting brackets. Using the factory bolt plate, mount the bracket to the frame. **See Figures 3-4.**

Fig. 3



PARKING SENSOR INSTALLATION

***If not installing sensors, install Hole Plugs into holes on bumper and proceed.**

5. Remove the parking sensors from the OEM bumper. Pay attention to the orientation of the sensors. They must be installed in the same orientation. Handle sensors with care, they are very delicate .
6. Use the Sensor Tab (4) along with the supplied M6 Hardware (10-13) to install the sensors as shown in **Figure 4-5**.
7. Carefully route the harness around the bumper.

Note: Zip ties or double sided tape can be used to route harness and to hold the sensor in position.

Fig. 4

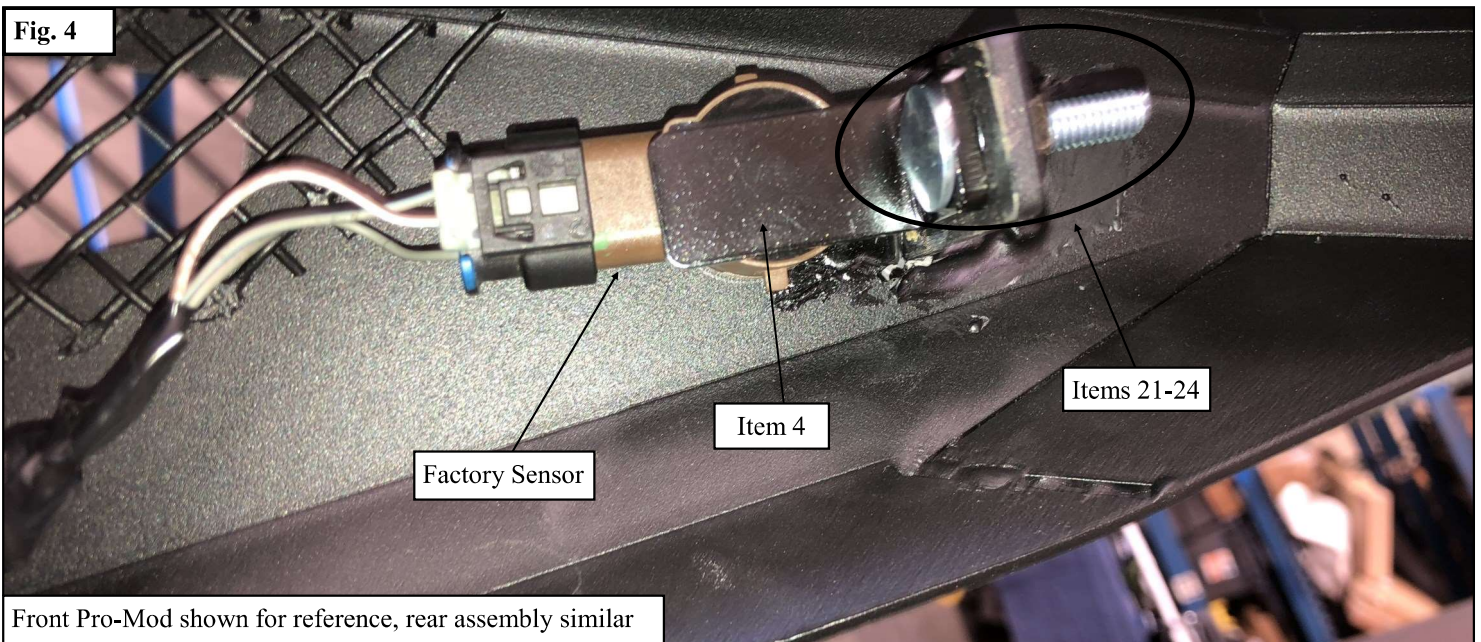

Factory Sensor

Item 4

Items 21-24

Front Pro-Mod shown for reference, rear assembly similar

Fig. 5

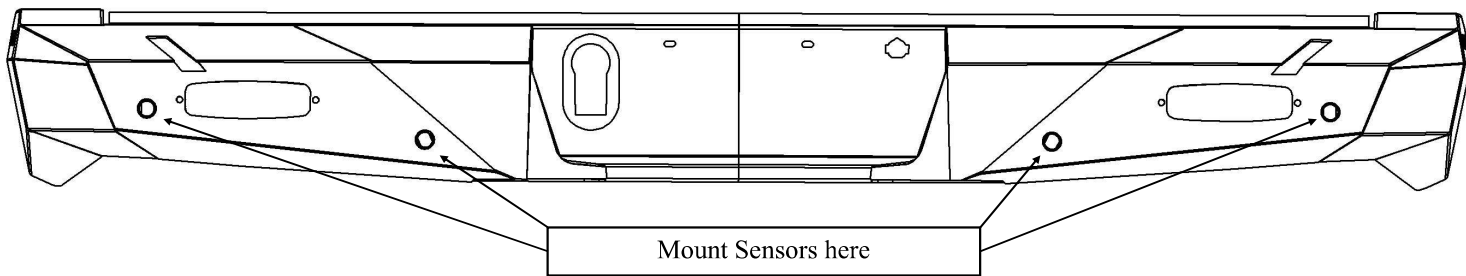

8. Using the supplied M12 hardware, loosely assemble the bumper to the mounting brackets. See Figure 6-7

Fig. 6

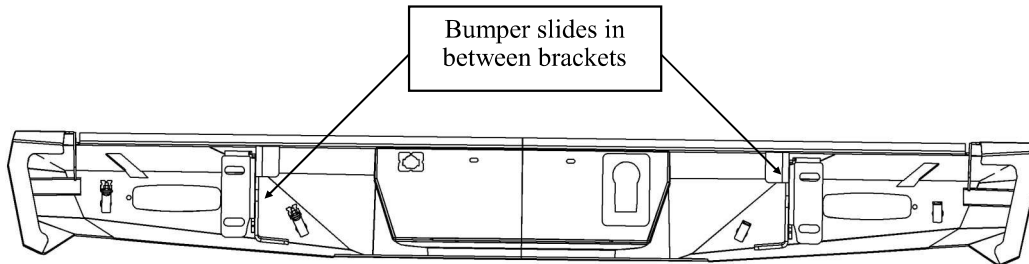
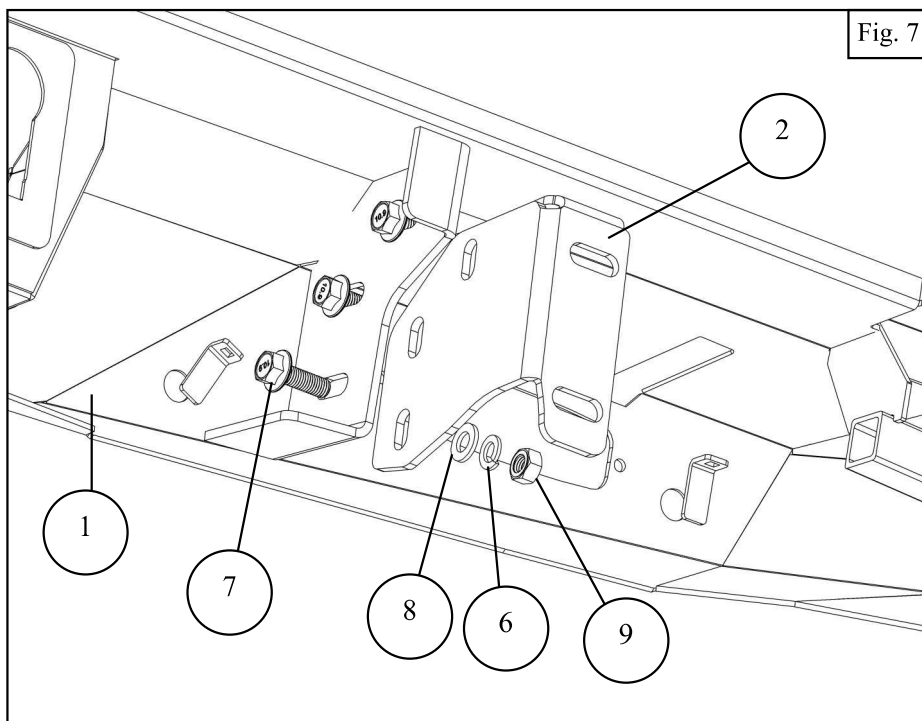

Fig. 7



9. Align bumper as desired and torque all hardware as specified: M6 to 7 ft-lbs, M12 to 60 ft-lbs.

License plate lights installation.

1. Disconnect the battery from your vehicle.
 2. Locate the license plate lights (pre-installed) in the bumper. Pop out the lights by squeezing the clips in on the backside.
See Figure 8
 3. Locate the factory wiring for the license plate lights. Strip back the wiring on the factory harness and supplied light. Using connectors, crimp the red wire on the positive factory wire and the black wire to the factory ground wire. **See Figure 9**
- Note: Only the portion shown on **Figure 10** will be needed from the connector.

Figure 8

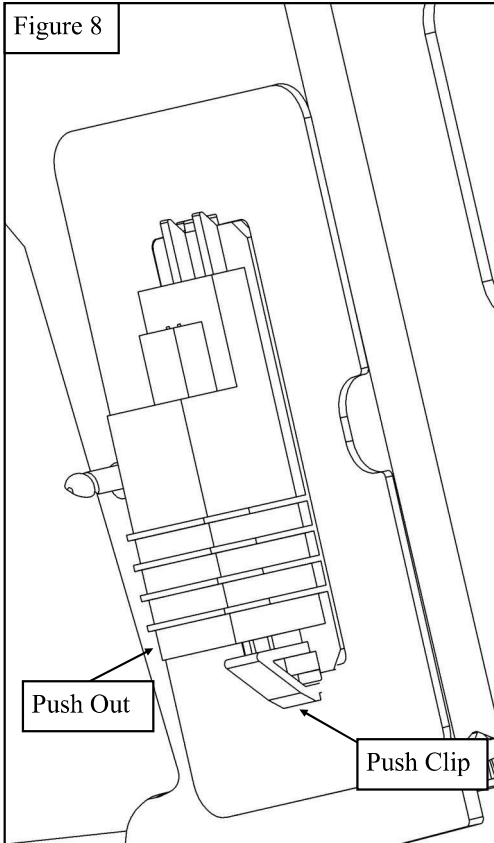
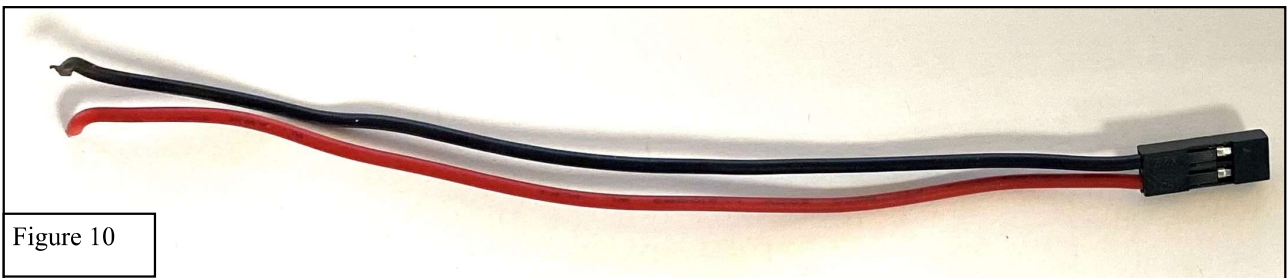

Figure 9



Figure 10



4. Push the light back in until it clips into place. Repeat on the opposite side. **See Figure 11**

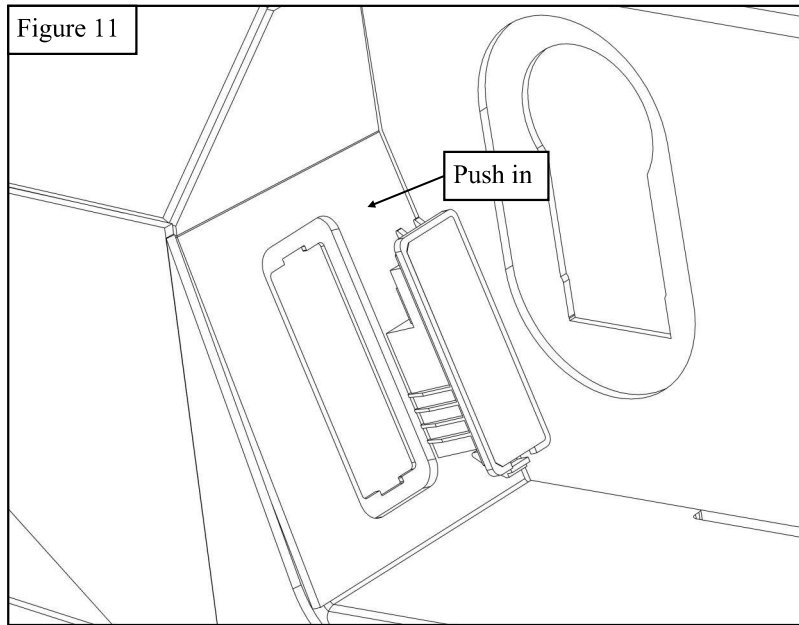

5. If you are installing the optional reverse lights, remove the mesh covers and install the optional lights with the M6 hardware. **See Figure 12**
6. Locate the factory wiring for the reverse lights. Strip back the wiring on the factory harness and supplied light. Using connectors, crimp the red wire on the positive factory wire and the black wire to the factory ground wire.
7. Reconnect your battery.

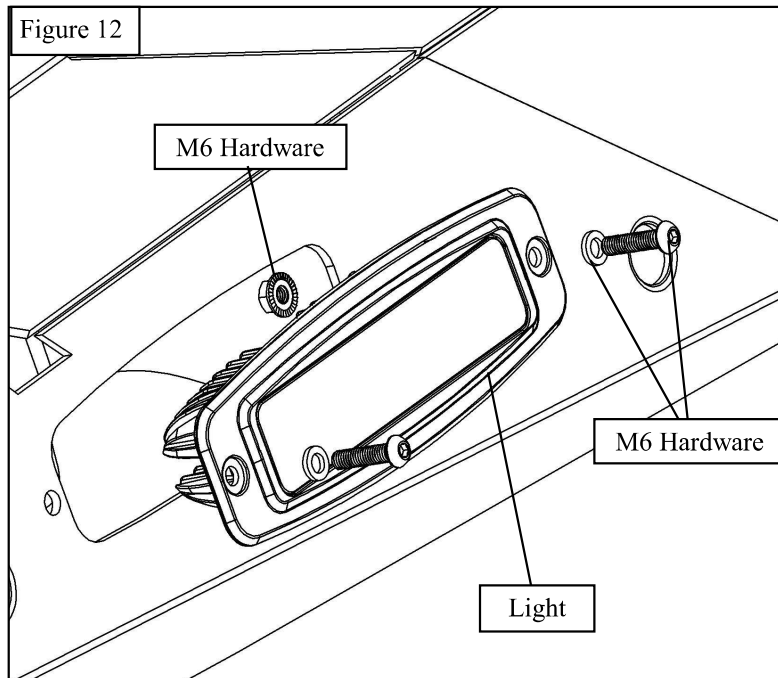

INSTALLATION COMPLETE



CARE INSTRUCTIONS

- REGULAR WAXING IS RECOMMENDED. DO NOT USE ANY TYPE OF POLISH OR WAX THAT MAY CONTAIN ABRASIVES.
- STAINLESS STEEL PRODUCTS CAN BE CLEANED WITH MILD SOAP AND WATER. STAINLESS STEEL POLISH SHOULD BE USED TO POLISH SMALL SCRATCHES.
- GLOSS BLACK FINISHES SHOULD BE CLEANED WITH MILD SOAP AND WATER.

WESTIN Westin Automotive Products, Inc.
320 W. Covina Blvd
San Dimas, Ca. 91773

Thank you for choosing Westin products
for additional installation assistance please call
Customer Service (800) 793-7846
www.westinautomotive.com



WARNING



Failure to follow these instructions could lead to death, personal injury, and / or property damage.

Failure to follow these instructions could lead to death, personal injury, and / or property damage.

FASTENERS:

All Westin supplied fasteners must be utilized and installed in accordance with the installation instructions and apply torque to the specifications as defined. **DOUBLE CHECK ALL FASTENERS BEFORE INITIAL USE, AND PERIODICALLY IN THE FUTURE TO ENSURE PROPER FUNCTION AND SAFETY.**

DRILLING:

Most Westin products do not require drilling for installation. If drilling is defined as required, use caution when drilling a vehicle. **FAILURE TO REVIEW AN AREA TO BE DRILLED MAY RESULT IN PERSONAL INJURY AND/OR INJURY TO OTHERS AS WELL AS VEHICLE DAMAGE.**

EYE PROTECTION:

ALWAYS WEAR SAFETY GLASSES OR GOGGLES DURING THE INSTALLATION PROCESS TO AVOID PERSONAL INJURY.

MAXIMUM TOWING/CARRYING CAPACITY: (if applicable)

The Westin Receiver Hitches will have a visible tow rating label affixed directly on the product. User should never exceed the vehicle manufacturers maximum tow and weight rating regardless of the capacity of the hitch. **FAILURE TO FOLLOW THESE GUIDELINES WILL VOID THE WESTIN WARRANTY AND MAY RESULT IN PERSONAL INJURY AND/OR INJURY TO OTHERS AS WELL AS VEHICLE DAMAGE.**

FOR CALIFORNIA RESIDENTS ONLY-PROP 65 WARNING:

Some products may contain chemicals such as DEHP, which can cause cancer, birth defects or other reproductive harm. For more info go to www.p65warnings.ca.gov