

PARTS LIST:

1	Front CS1 Overlay Bumper Assembly	4	10mm x 20mm OD x 2mm Flat Washers
1	Driver/Left Frame Mounting Bracket	4	10mm Lock Washers
1	Passenger/Right Frame Mounting Bracket	4	10mm Hex Nuts
2	Lower Support Brackets	2	8-1.25mm x 25mm Hex Bolts
1	Driver/Left Mesh Plate	2	8-1.25mm x 16mm Hex Bolts
1	Passenger/Right Mesh Plate	6	8mm x 24mm x 2mm Flat Washers
2	LED "L" Light Brackets	4	8mm Lock Washers
1	License Plate Relocation Bracket	2	8mm Hex Nuts
2	Plastic Plugs for license plate mount	4	6mm x 20mm Button Head Combo Bolts
2	Bumper Edge Trim	10	6mm x 20mm Button Head Bolts
2	12mm Double Nut Plates	4	6mm x 18mm x 1.6 Flat Washers
4	12-1.75mm x 40mm Hex Bolts	2	6mm Nylon Lock Nuts
4	12mm x 32mm x 3mm Flat Washers	1	Allen Wrench S=4
4	12mm Lock Washers	10	Nylon Wire Ties
2	10mm Double Bolt Plates (L-shaped bracket)		

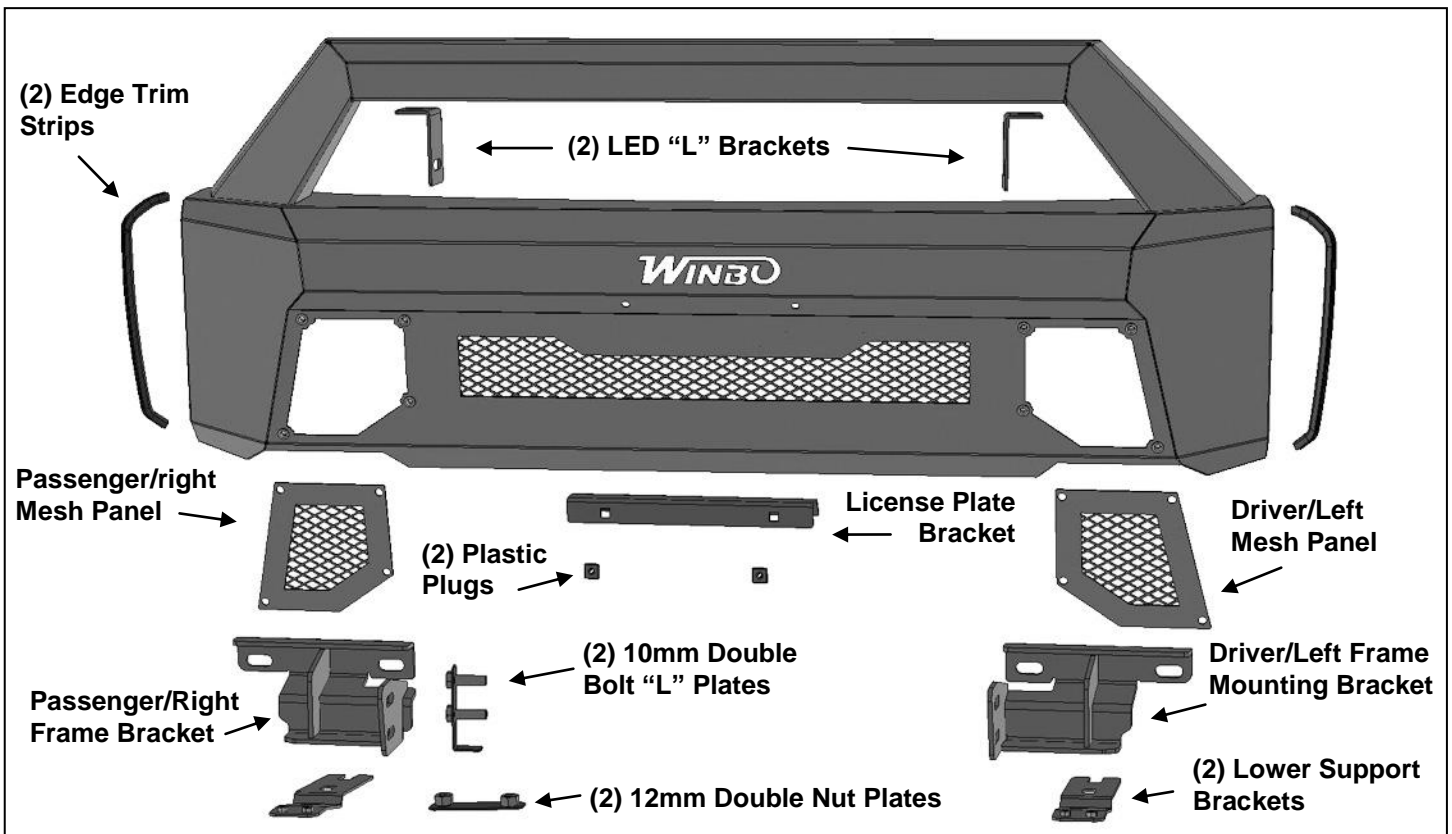

PROCEDURE:

REMOVE CONTENTS FROM BOX. VERIFY ALL PARTS ARE PRESENT. READ INSTRUCTIONS CAREFULLY BEFORE STARTING INSTALLATION. ASSISTANCE IS HIGHLY RECOMMENDED TO AVOID POSSIBLE INJURY OR DAMAGE TO THE VEHICLE.

1. Remove the license plate and bracket. Next, remove the plastic bumper pads from the bumper, (**Figure 1**). **NOTE:** Pull bumper pads straight out to release metal clips. Unplug and remove the adaptive cruise control, if equipped.
2. Remove the (2) factory hex nuts attaching the driver/left side of the bumper to the end of the frame, (**Figure 2**). Select the driver/left side Frame Mounting Bracket, (**Figures 3 & 4**). Reuse the factory hex nuts to attach the Frame Mounting Bracket to the inner bumper bracket and frame. Do not fully tighten hardware at this time. Repeat this Step to install the passenger/right Frame Bracket.

3. Determine if vehicle is equipped with tow hooks to install lower Support Brackets.

Models with tow hooks

- a. Remove the rubber seal around the tow hook. Remove the front bolt but only loosen the rear mounting bolt, **(Figure 5)**. Leave tow hook in place.
- b. Select (1) Support Bracket. Slide the Support Bracket between the tow hook and the bottom of the frame, **(Figures 6 & 7)**. Reinstall the front factory tow hook bolt. Do not fully tighten hardware at this time. **NOTE:** Cut the rubber seal to reinstall over Bracket, **(Figure 8)**.

Models without tow hooks.

- a. Select the included (1) 12mm Double Nut Plate. Apply a short piece of tape, (duct or masking tape for example) to the end of the Nut Plate to act as a temporary handle, **(Figure 9)**. Slide the Nut Plate into the open end of the frame and over the holes in the bottom of the frame, **(Figure 5)**. **NOTE:** On some models, it may be necessary to loosen or remove the large hex nuts (1 per side) attaching the back of the bumper to the bumper bracket to tilt the bumper forward to insert the Double Nut Plates into the frame, **(Figure 10)**.
 - b. Select (1) Support Bracket. Use a sharp knife or hacksaw blade to cut a slot out of the lower plastic splash guard to clear the Support Bracket, **(Figure 11)**.
 - c. Slide the Support Bracket through the slot and attach the Support Bracket to the bottom of the frame and Double Nut Plate with the included (2) 12mm x 40mm Hex Bolts, (2) 12mm Lock Washers and (2) 12mm Flat Washers, **(Figure 12)**. Do not tighten.
4. Repeat the appropriate **Step 3** to install the passenger/right Support Bracket.
 5. Carefully unwrap the Bumper. Attach the included Edge Trim to the sides of the Bumper, **(Figure 13)**.
 6. On vehicles requiring front license plate, select the License Plate Bracket. Attach the Bracket to the front of the Bumper with the included (2) 6mm x 20mm Button Head Bolts, (4) 6mm Flat Washers and (2) 6mm Nylon Lock Nuts, **(Figure 14)**. Push the included (2) push-in Plastic Plugs into the square holes in the Bracket. Reuse the factory hardware to attach the license plate to the Plastic Plugs.
 7. With assistance, position the mounting tabs on the back of the Bumper up to the inside of the Frame Brackets. Temporarily support Bumper. **WARNING:** To avoid possible injury or damage to the vehicle, do not proceed until the bumper is fully and safely supported.
 8. Select (1) Double Bolt Plate. Insert the Bolt Plate through the outer opening in the Bumper, **(Figure 15)**. Guide the Bolt Plate into, up and through the back of the Brackets. Attach the Bumper to the Bolt Plate with (2) 12mm Flat Washers, (2) 12mm Lock Washers and (2) 12mm Hex Nuts, **(Figure 16)**. Do not tighten hardware. Repeat this Step to attach the passenger/right side of the Bumper to the Mounting Bracket.
 9. Line up the mounting hole in the driver/left Support Bracket with the holes in the bottom of the Bumper. Attach the Support Bracket to the inside of the Bumper with the included (2) 6mm Button Head Combo Bolts, **(Figure 16)**. Do not fully tighten hardware. Repeat this Step to attach the passenger/right Support Bracket.
 10. Check the Bumper for level and centered on the vehicle. Adjust the Bumper as necessary and fully tighten all Mounting Bracket hardware. **NOTE:** If additional left-right adjustment is required, temporarily loosen the Frame Bracket hardware and slide the Brackets left or right as necessary and fully tighten Frame Bracket hardware.
 11. Once hardware has been fully tightened, attach Mesh Fill Panels to Bumper with the included (8) 6mm x 20mm Button Head Bolts, **(Figure 17)**
 12. Top mounted LED light installation (optional-light not included).
 - a. Select (1) LED "L" Light Bracket. Attach the Bracket to the bottom of the top hoop with (1) 8mm x 25mm Hex Bolt, (2) 8mm Flat Washers, (1) 8mm Lock Washer and (1) 8mm Hex Nut, **(Figure 18)**. Do not tighten hardware at this time.
 - b. Repeat previous Step to attach the passenger/right Bracket.
 - c. Attach light to Top Brackets with the hardware included with the light or the included (2) 8mm x 16mm Hex Bolts, (2) 8mm Lock Washers and (2) 8mm Flat Washers. Adjust the width of the Brackets to the light. **IMPORTANT:** Top Light Brackets are designed to install most 20" to 24" single and double row bar style LED lights.
 - d. "L" Brackets installed to the inside will accommodate a light 21-3/8" to 23-3/16" wide.
 - e. "L" Brackets installed to the outside will accommodate a light 24-9/16" to 26-5/16" wide.

f. Fully tighten top light hardware once adjusted.

13. Do periodic inspections to the installation to make sure that all hardware is secure and tight.

To protect your investment, Do not use any type of polish or wax that may contain abrasives that could damage the finish. Mild soap may be used to clean the Front Bumper assembly.

Driver Side Installation Pictured

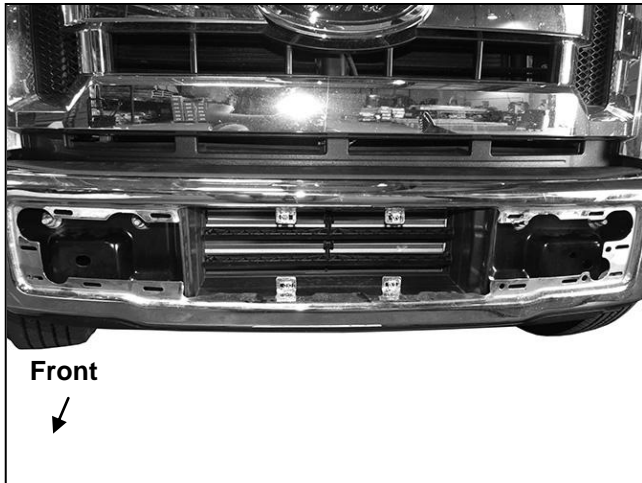

(Fig 1) Remove license plate. Pull plastic bumper pad straight out to release from clips

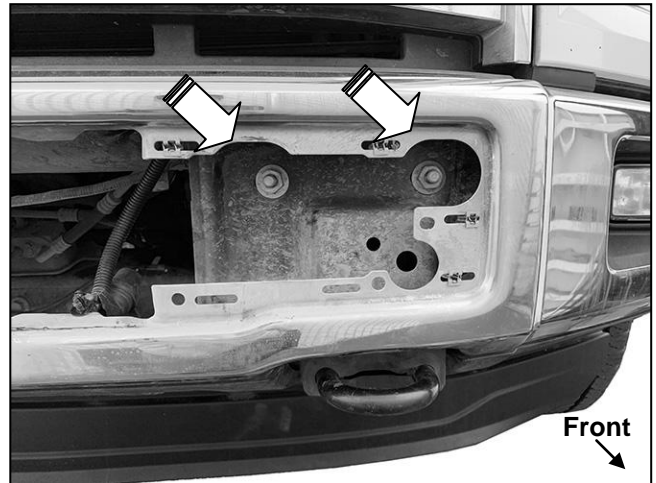

(Fig 2) Remove (2) factory hex nuts (arrows)

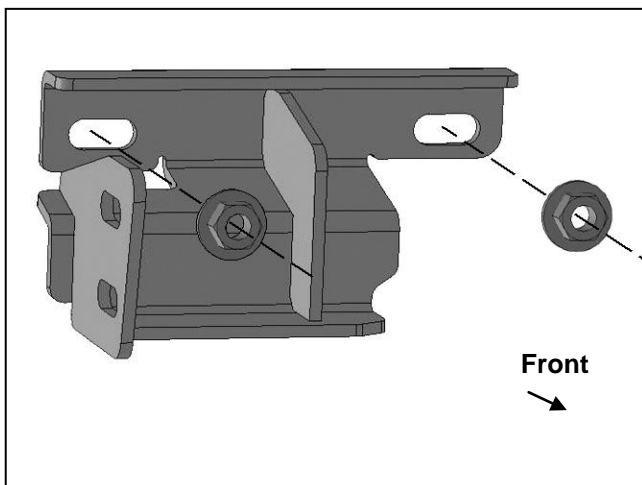

(Fig 3) Reuse factory hex nuts to install Frame Mounting Brackets (driver/left Frame Bracket illustrated)



(Fig 4) Driver/left Frame Bracket installed

Driver Side Installation Pictured



(Fig 5) Models with tow hooks, remove forward bolt, loosen but do not remove rear bolt to hold factory double nut plate in place in frame

Reuse factory bolts or
(2) 12mm x 40mm Hex Bolts
(2) 12mm Lock Washers
(2) 12mm Flat Washers

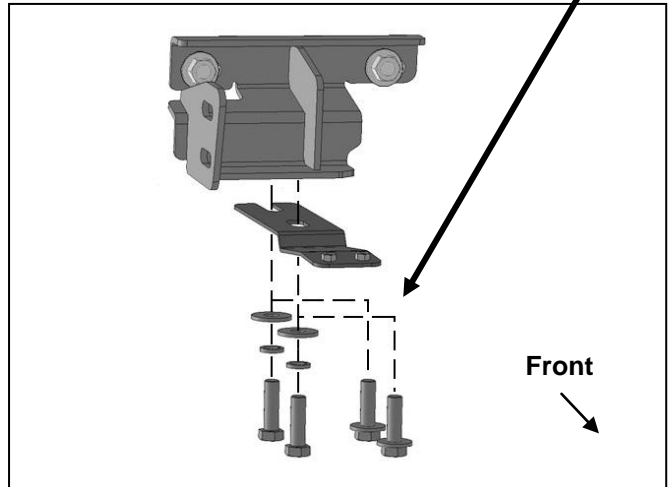

(Fig 6) Models with tow hooks, insert Support Bracket between bottom of frame and tow hook



(Fig 7) Brackets installed, model with tow hook pictured

Cut slot to clear
Support Bracket



(Fig 8) Models with tow hooks, cut a slot from the rubber seal to clear the Support Brackets

Driver Side Installation Pictured

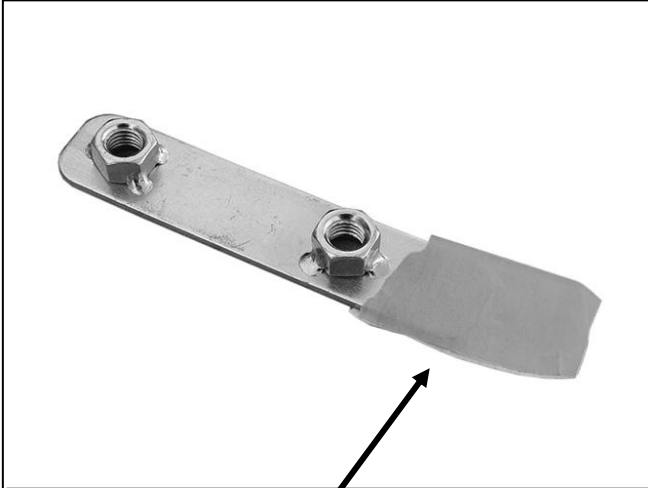

(Fig 9) If necessary, apply tape (masking, duct tape for example) to extend the reach to line up the Double Nut Plate with holes in the frame

Cut slot to clear Support Bracket



(Fig 11) Models without tow hooks, cut a slot from the plastic splash guard to clear the Support Brackets

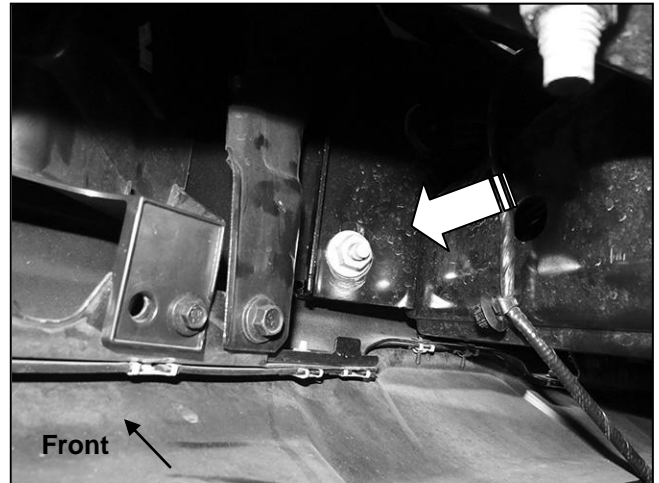

(Fig 10) Models without tow hooks, loosen the front hex nuts to tilt the bumper enough to insert the Double Nut Plates into the end of the frame. Remove factory hex nut (arrow) from back of bumper bracket and tilt bumper forward

Double Nut Plate

- (2) 12mm x 40mm Hex Bolts
- (2) 12mm Lock Washers
- (2) 12mm Flat Washers

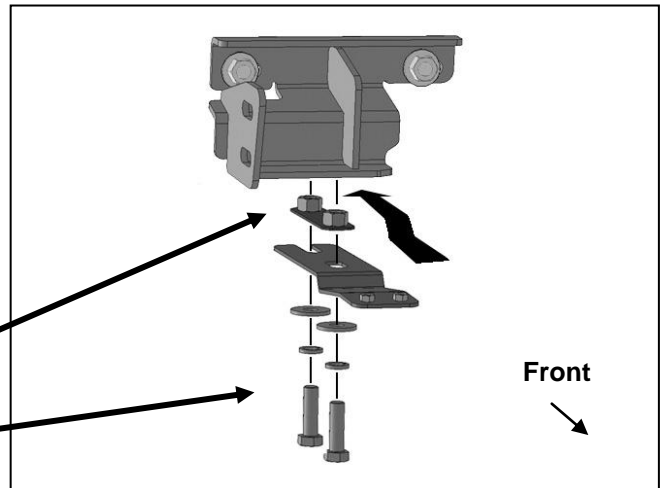

(Fig 12) Attach Support Bracket to Double Nut Plate in frame

Driver Side Installation Pictured

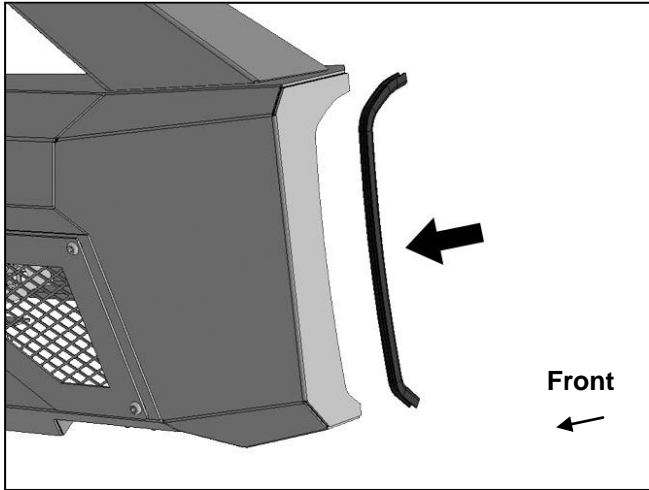

(Fig 13) Push Edge Trim onto both ends of Bumper

- (2) 6mm x 20mm Button Head Bolts
- (4) 6mm Flat Washers
- (2) 6mm Nylon Lock Nuts

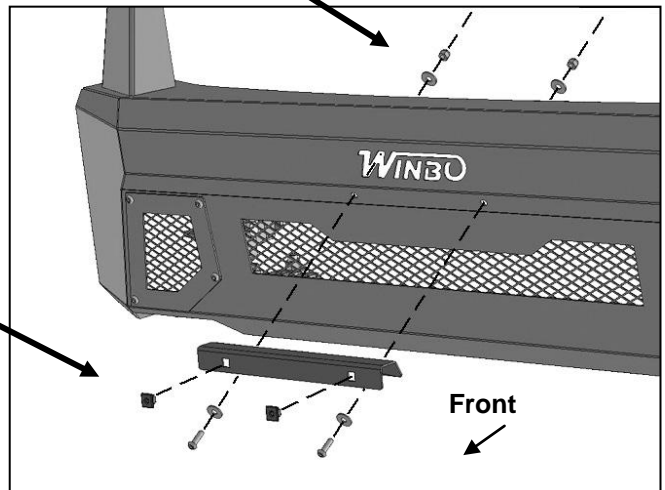

- (2) Plastic Plugs

(Fig 14) Attach Support Bracket to top of Bracket Assembly and factory tow hook (if equipped)

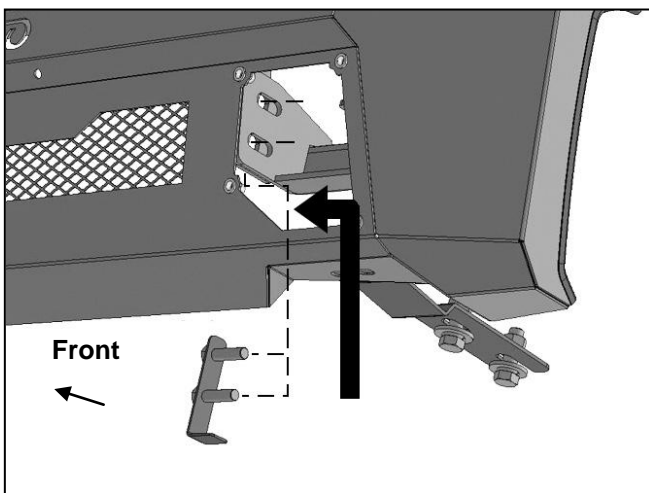

(Fig 15) Insert Double Bolt up and through back of tab on Bumper and Frame Bracket

Driver Side Installation Pictured

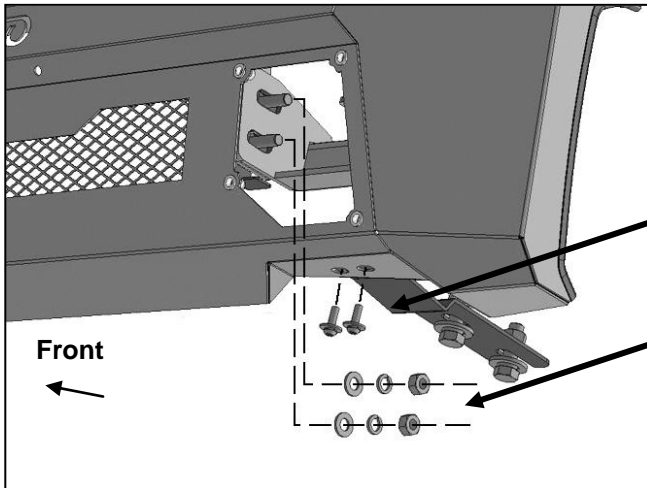

(2) 6mm x 20mm Combo Bolts

(2) 10mm Flat Washers
(2) 10mm Lock Washers
(2) 10mm Hex Nuts

(Fig 16) Attach driver/left side of Bumper to Double Bolt Plate. Attach bottom of Bumper to Support Bracket

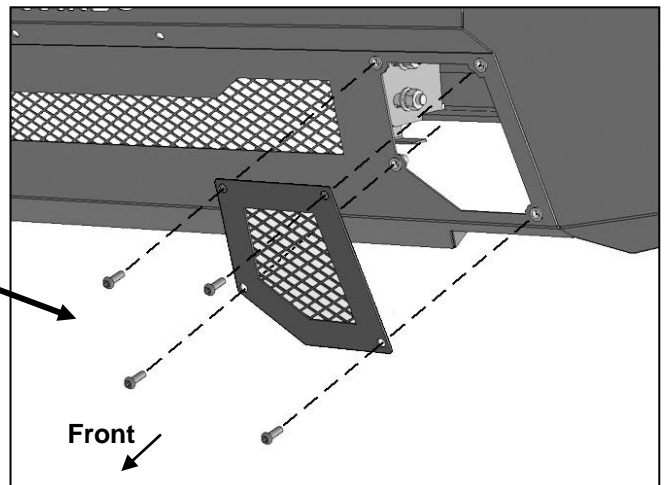

(4) 6mm x 20mm
Button Head Bolts

8mm x 16mm Hex Bolt
8mm Lock Washer
8mm Flat Washer

8mm x 25mm Hex Bolt
(2) 8mm Flat Washers
8mm Lock Washer
8mm Hex Nut

(Fig 17) Attach driver/left Mesh Panel after Bumper has been adjusted and hardware fully tightened

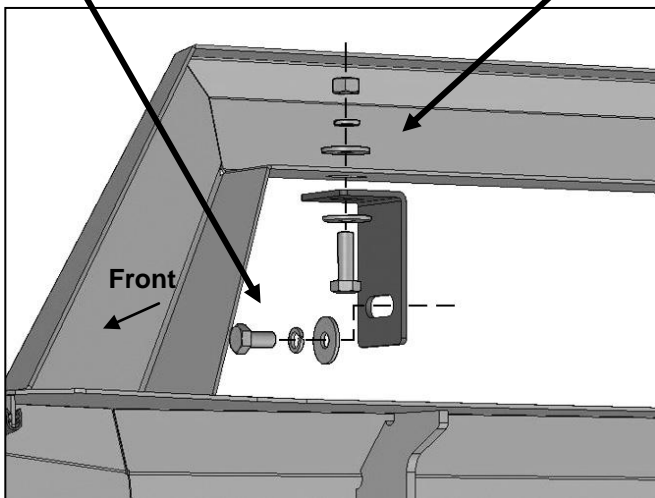

(Fig 18) Attach LED "L" Brackets to bottom of loop. NOTE: Top Light bracket mounting location is designed for 20-24" single or double row bar style light. Flip Brackets around if necessary



Complete Installation