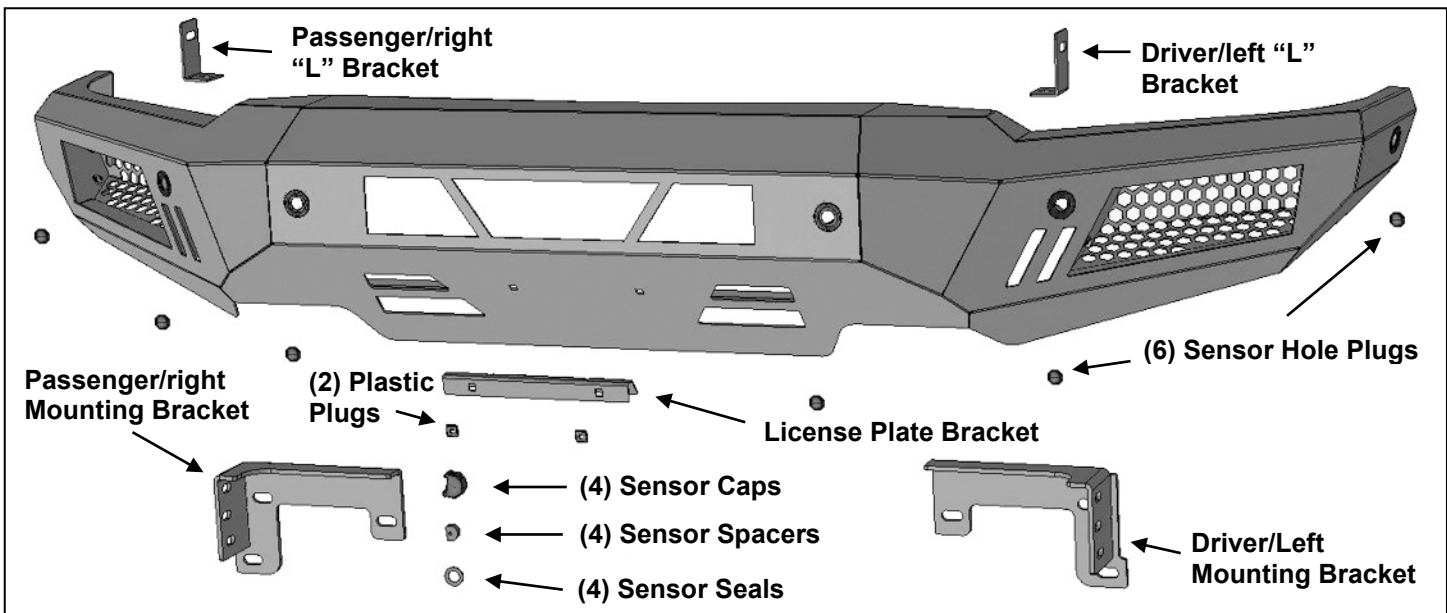

PARTS LIST:

1	Front Bumper Assembly	12	10mm x 27mm x 3mm Flat Washer
1	Driver/left Frame Bracket	6	10mm Lock Washer
1	Passenger/right Frame Bracket	6	10mm Hex Nut
1	Driver/left "L" Bracket (center LED light)	2	8-1.25mm x 25mm Hex Bolts
1	Passenger/right "L" Bracket (center LED light)	2	8-1.25mm x 16mm Hex Bolts (LED light bar)
1	License Plate Bracket	6	8mm x 24mm Flat Washers
2	Plastic Plugs for license plate mount	4	8mm Lock Washers
6	Sensor Retaining Caps	2	8mm Hex Nuts
6	20mm x 10mm Foam Spacers	2	6mm x 20mm Button Head Bolts
6	15.5mm x 25mm x 2mm Foam Seals	4	6mm x 18mm x 1.6 Flat Washers
6	Plastic Sensor Hole Plugs	2	6mm Nylon Lock Nuts
6	12-1.75mm x 35mm Hex Bolt	12	4mm Self Tapping Screws
12	12mm x 32mm x 3mm Flat Washer	1	4mm Wrench
6	12mm Nylon Lock Nut	10	Nylon Wire Ties
6	10-1.5mm x 35mm Hex Bolt		

**PROCEDURE:**

REMOVE CONTENTS FROM BOX. VERIFY ALL PARTS ARE PRESENT. READ INSTRUCTIONS CAREFULLY BEFORE STARTING INSTALLATION. BUMPER IS HEAVY, ASSISTANCE IS HIGHLY RECOMMENDED TO AVOID POSSIBLE INJURY OR DAMAGE TO THE VEHICLE. BUMPER IS NOT COMPATIBLE WITH ACC (ADAPTIVE CRUISE CONTROL). FUNCTION MUST BE DISABLED OR SENSOR RELOCATED.

1. Remove the license plate and bracket.
2. From behind the front bumper, unplug and remove the active air dam from the bottom of the frame, **(Figures 1 & 2)**. It is not necessary to remove the lift motors, only remove the (6) bolts to remove the air dam.
3. With the air dam out of the way, locate and unplug the main harness plug on the top of the passenger/right frame rail behind the bumper bracket, **(Figure 3)**. Unplug any remaining harnesses leading to the bumper. On hybrid models, temporarily unplug and remove the speaker assembly for the pedestrian audible alert system from the driver/left frame channel, **(Figure 4)**. Note speaker is located on the inner side of the frame, behind the driver/left bumper bracket. From below, remove the hex bolt and drop the speaker down, unplug and remove, **(Figure 5)**.

4. Place blocks or jack stands under the front bumper to support it during mounting hardware removal. Once the bumper has been safely supported, remove the large hex nuts from the back of each bumper bracket attaching the bumper to the bumper brackets, **(Figure 6)**. **WARNING!** Assistance is required to hold the bumper in place during hardware removal to prevent the bumper from falling. Carefully slide the bumper off over the tow hooks if equipped.
5. On models with bolt on frame extensions, remove the extensions from outside of frame, **(Figure 6)**. **NOTE:** It may be necessary to cut the factory bolts to remove frame extensions, (removal is optional).
6. Select the driver/left Frame Mounting Bracket. Attach the Bracket to the end of the frame with the included (3) 12mm x 35mm Hex Bolts, (6) 12mm Flat Washers and (3) 12mm Nylon Lock Nuts, **(Figures 7 & 8)**. Do not fully tighten hardware at this time. Repeat this Step to install the passenger/right Frame Bracket.
7. Determine if the vehicle is equipped front sensors:

Models without bumper sensors:

- a. Select the included (6) Plastic Plugs.
- b. From the front, push the plugs into the sensor mounting holes, **(Figure 9)**.

Models with bumper mounted sensors:

- a. Disassemble front bumper to unplug and remove sensors and wiring harness from bumper. Pay attention to mounting location of all sensors for proper reinstallation.
 - b. Select the driver/left outer sensor. Remove the silicone seal from the end of the sensor. Slide the included larger Foam Sensor Seal over front of sensor, **(Figure 10)**.
 - c. Insert sensor with Seal into driver/left outer sensor mount, **(Figure 11)**.
 - d. Place Foam Spacer over end of sensor. Push Sensor Retaining Cap onto sensor mount and lock into mounting holes, **(Figure 11)**.
 - e. Repeat previous Steps to install remaining sensors.
 - f. Install wiring harness for sensors. **NOTE:** it may be necessary to remove some of the protective wrap around the harness to reach all sensor mounts.
 - g. **Optional:** Secure each sensor to the socket with (2) 4mm Self Tapping Screws. **IMPORTANT:** Sensors fit snug in sockets. The 4mm Screws are used to apply slight pressure to lock the sensors in place. Tighten both screws evenly until they touch the sensor body only. Do not overtighten screws or damage to sensors will result.
8. If front license plate is required, attach the License Plate Bracket to the holes in the bumper with the included (2) 6mm x 20mm Button Head Screws, (4) 6mm Flat Washers and (2) 6mm Nylon Lock Nuts. Insert (2) Plastic Plugs into the square holes in the Bracket. Reuse the factory screws to attach the license plate to the Plastic Plugs, **(Figure 12)**.
 9. **Center LED light installation** (sold separately).
 - a. Select the L/R "L" Brackets, **(Figure 13)**. Attach the Brackets to the top of the (2) mounting tabs welded onto the back of the Bumper with the included 8mm x 25mm Hex Bolts, (4) 8mm Flat Washers, (2) 8mm Lock Washers and (2) 8mm Hex Nuts. Leave loose at this time.
 - b. Attach the LED light assembly to the "L" Brackets with the included (2) 8mm x 16mm Hex Bolts, (2) 8mm Lock Washers and (2) 8mm Flat Washers, **(Figure 13)**. Do not fully tighten hardware at this time. **IMPORTANT:** "L" Brackets are designed for 8mm light mounting hardware only. Modify "L" Brackets if necessary or use brackets supplied by the light manufacturer to install hardware larger than 8mm.
 - c. Follow light manufacturer's instructions to properly wire the light.
 10. **LED light installation at ends of bumper** (sold separately).
 - a. Insert light into opening and up to mounting slots in the top of the driver/left light opening.
 - b. Check for clearance between front and back of light. If necessary, remove the screen from the back of the opening, **(Figure 14)**.
 - c. Follow the light manufacturer's instructions to attach (1) light to the center slot or (2) lights to the inner and outer slots in the top of the light opening. **IMPORTANT:** On two light systems with (1) flood and (1) spot light per side, attach the flood light to the outer and the spot light to the inner slot.
 - d. Repeat the above Steps for passenger/right side light installation.
 - e. Follow light manufacturer's instructions to properly wire the light.

11. With assistance, position the Bumper Assembly up to the outside of the Mounting Brackets. Temporarily support the weight of the Bumper. **NOTE:** On models with ecoboost, trim plastic shroud to fit Bumper profile as needed. **WARNING:** To avoid possible injury or damage to the vehicle, do not proceed until the bumper is fully and safely supported.
12. Attach the driver/left mounting plate on the back of the Bumper to the outside of the Mounting Bracket with the included (3) 10mm x 35mm Hex Bolts, (6) 10mm Flat Washers and (3) 10mm Nylon Lock Nuts, (**Figures 15 & 16**). Repeat this Step to attach the passenger/right side of the Bumper to the Bracket. Do not fully tighten hardware at this time.
13. Level and adjust the bumper and fully tighten all hardware.
14. Do periodic inspections to the installation to make sure that all hardware is secure and tight.

To protect your investment, Do not use any type of polish or wax that may contain abrasives that could damage the finish. Mild soap may be used to clean the Bumper assembly.

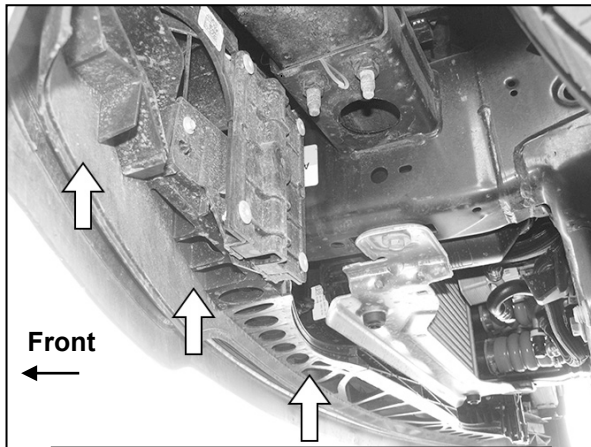

(Fig 1) Active air dam behind bumper

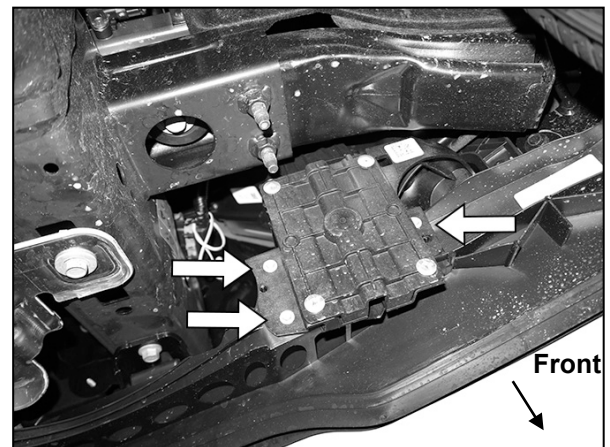

(Fig 2) Remove bolts (arrows) to remove active air dam from motors (passenger/right side pictured)

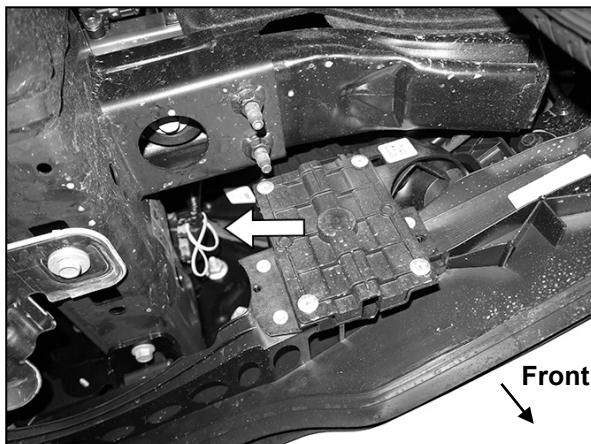

(Fig 3) Locate and unplug main harness plug on passenger/right side of bumper (arrow)

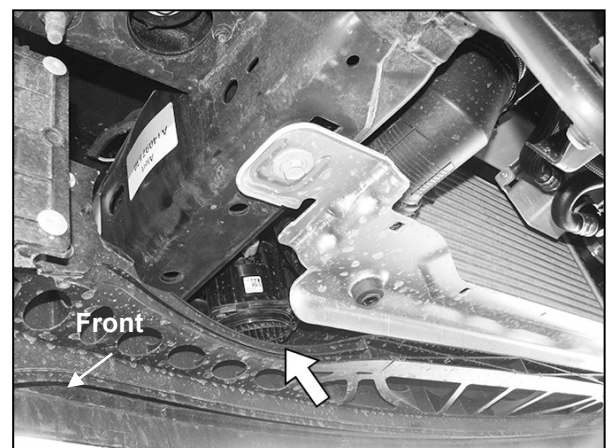

(Fig 4) Hybrid Models Only, locate alert speaker behind driver/left side of bumper

WARNING! Do not remove bumper bolts unless it is properly supported on blocks or stands or the bumper may fall.



(Fig 5) Remove bolt (arrow) to temporarily remove audible alert speaker located behind driver/left side of bumper (hybrid models only-pictured from below)

WARNING! Do not remove bumper bolts unless it is properly supported on blocks or stands or the bumper may fall.

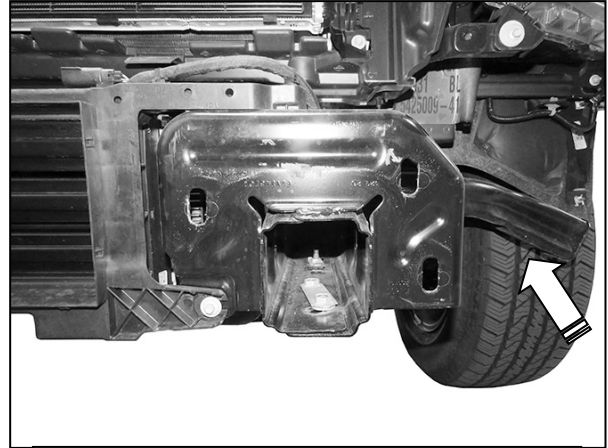

(Fig 6) Remove bumper. Also remove the factory frame extension (arrow-optional)

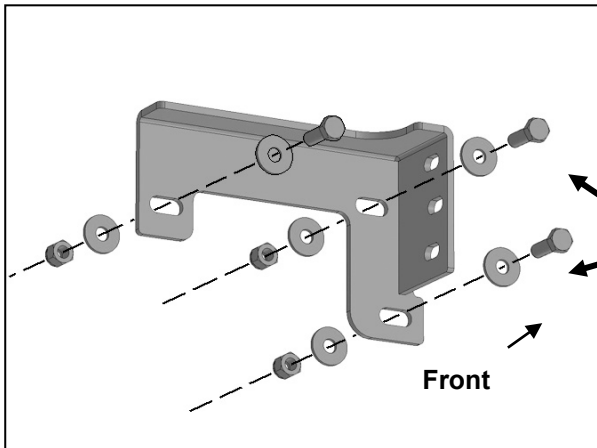

- (3) 12mm x 35mm Hex Bolts
- (6) 12mm Flat Washers
- (3) 12mm Nylon Lock Nuts

(Fig 7) Attach driver/left Frame Mounting Bracket to end of frame



(Fig 8) Driver/left side Bracket installed

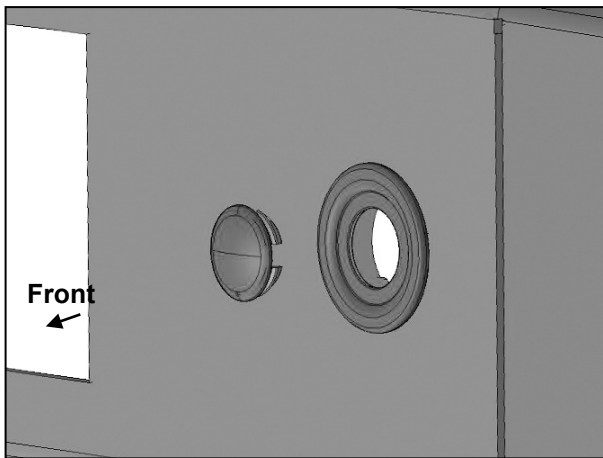

(Fig 9) Push Plastic Plug into sensor mount

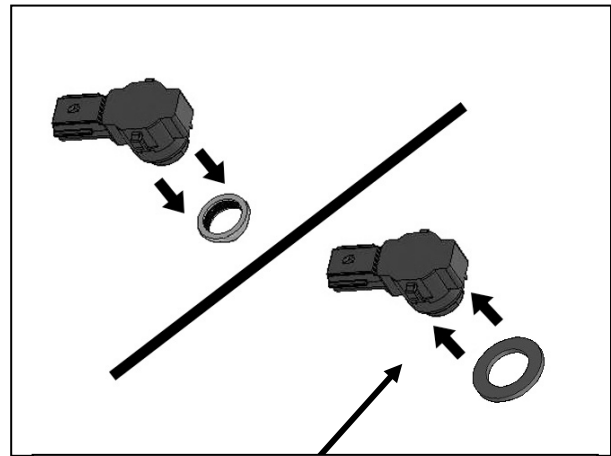

(Fig 10) Remove silicone seal from sensor. Slide large Seal over end of sensor (arrow)

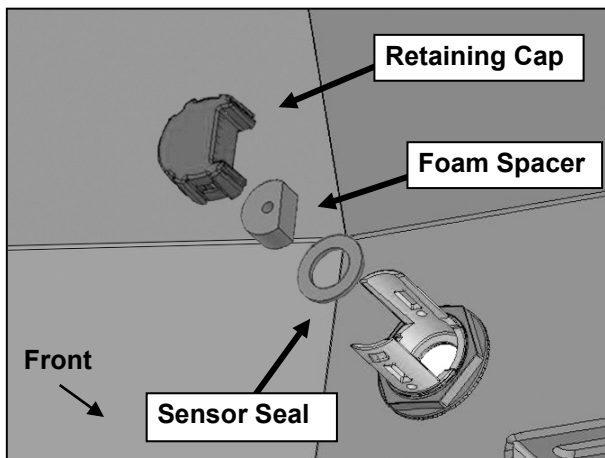

(Fig 11) Insert sensor assembly into the sensor mount on back of Bumper

- (2) 6mm x 20mm Button Head Screws
- (4) 6mm Flat Washers
- (2) 6mm Nylon Lock Nuts

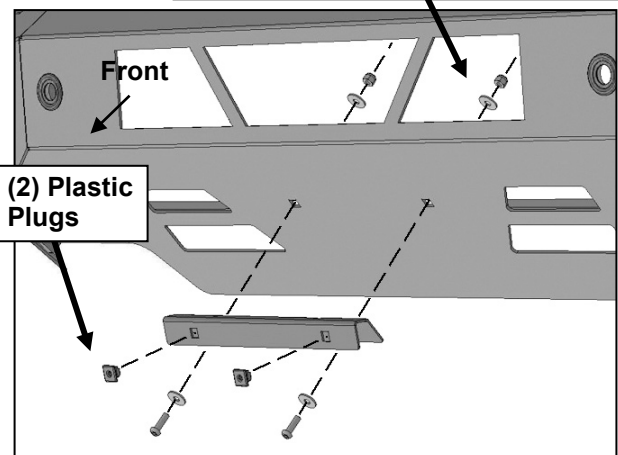

(Fig 12) Attach License Plate Bracket to Bumper

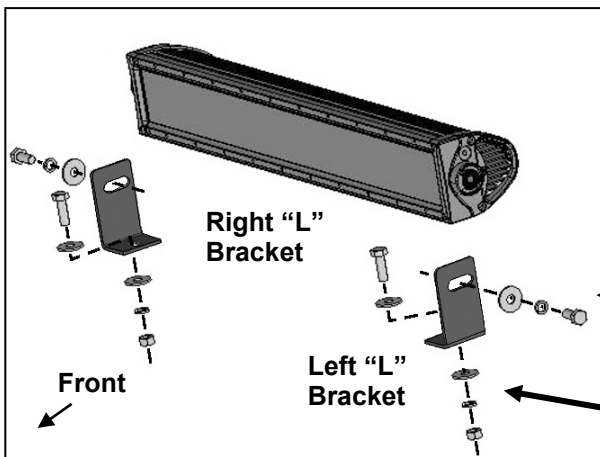

(Fig 13) Example of center light installation

- (2) 8mm x 16mm Hex Bolts
- (2) 8mm Lock Washers
- (2) 8mm Flat Washers

- (2) 8mm x 25mm Hex Bolts
- (4) 8mm Flat Washers
- (2) 8mm Lock Washers
- (2) 8mm Hex Nuts

Driver/left Side Installation Pictured

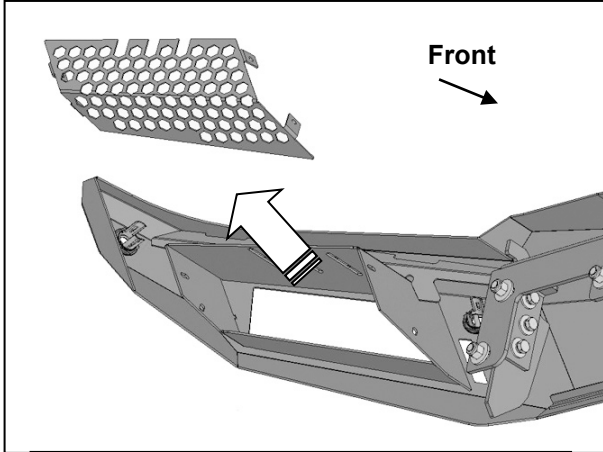

(Fig 14) Remove screens if necessary for clearance/access to outer light mounts

- (3) 10mm x 35mm Hex Bolts
- (6) 10mm Flat Washers
- (3) 10mm Lock Washers
- (3) 10mm Hex Nuts

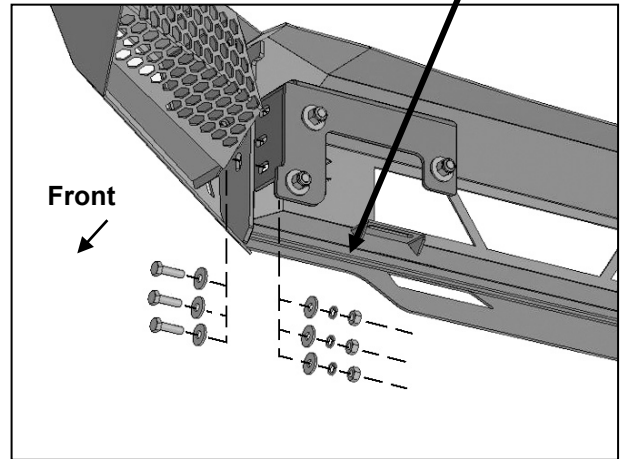

(Fig 15) Attach Bumper to Frame Mounting Bracket (passenger/right side illustrated)



(Fig 16) Passenger/right side of Bumper attached to Bracket (pictured from below)

